



# Service Manual

---

Models: GWH07NA-K3NNA4A(Cold Plasma)  
GWH07NA-K3NNB3A(Cold Plasma)  
GWH07NA-K3NNA8A  
GWH07NA-K3NND2A  
GWH09NB-K3NNE2A  
GWH09NA-K3NNA2A  
GWH09NA-K3NNA2C  
GWH09NA-K3NNA2A(Membrana Decorative Strip)  
GWH09NA-K3NNA4A(Cold Plasma)  
GWH09NA-K3NNB3A(Cold Plasma)  
GWH09NA-K3NNB3C(Cold Plasma)  
GWH12NB-K3NNA2A(Membrana Decorative Strip)  
GWH12NB-K3NNA2A  
GWH12NB-K3NNA4A(Cold Plasma)  
GWH12NB-K3NNC7C  
(Refrigerant R410A)

---

## Table of Contents

<b>Summary and Features</b> .....	1
<b>1. Safety Precautions</b> .....	3
<b>2. Specifications</b> .....	4
2.1 Unit Specifications.....	4
2.2 Capacity Variation Ratio According to Temperature .....	12
2.3 Operation Data .....	12
<b>3. Construction Views</b> .....	13
3.1 Indoor Unit.....	13
3.2 Outdoor Unit .....	14
<b>4. Refrigerant System Diagram</b> .....	15
<b>5. Schematic Diagram</b> .....	16
5.1 Electrical Wiring.....	16
5.2 Printed Circuit Board .....	21
<b>6. Function and Control</b> .....	24
6.1 Remote Control Operations.....	24
6.2 Description of Each Control Operation.....	26
<b>7. Installation Manual</b> .....	30
7.1 Notices for Installation .....	30
7.2 Installation Dimension Diagram.....	32
7.3 Install Indoor Unit .....	33
7.4 Install Outdoor Unit.....	34
7.5 Check after Installation and Test Operation .....	35
7.6 Installation and Maintenance of Healthy Filter .....	36

---

<b>8. Exploded Views and Parts List</b> .....	37
8.1 Indoor Unit.....	37
8.2 Outdoor Unit.....	54
<b>9. Troubleshooting</b> .....	60
9.1 Troubleshooting.....	60
9.2 Confirmation .....	60
9.3 Judgement by Flashing LED of Indoor/Outdoor Unit.....	61
9.4 How to Check Simply the MainPart .....	62
<b>10. Removal Procedure</b> .....	69
10.1 Removal Procedure of Indoor Unit.....	69
10.2 Removal Procedure of Outdoor Unit.....	77

---

# Summary and Features

## Indoor Unit:

GWH07NA-K3NNA4A/I(Cold Plasma)  
GWH09NA-K3NNA4A/I(Cold Plasma)  
GWH12NB-K3NNA4A/I(Cold Plasma)

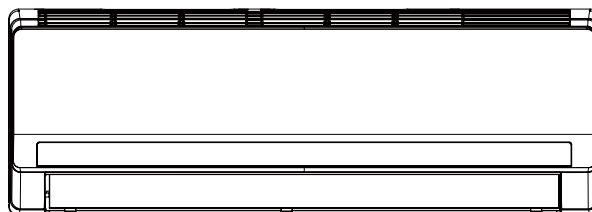

GWH07NA-K3NNA8A/I

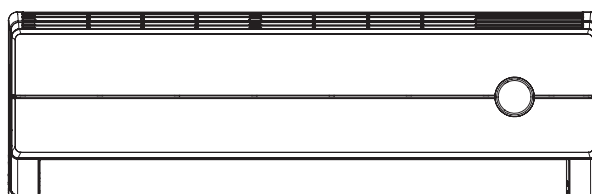

GWH07NA-K3NND2A/I

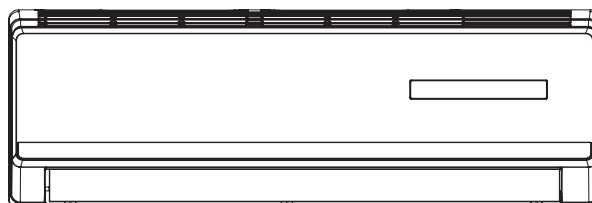

GWH09NB-K3NNE2A/I

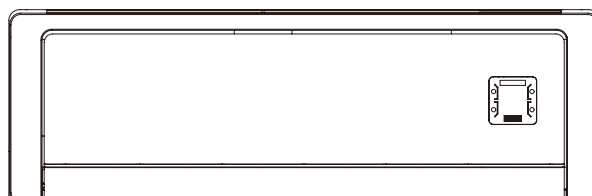

GWH09NA-K3NNA2C/I  
GWH09NA-K3NNA2A/I  
GWH09NA-K3NNA2A/I(Membrana Decorative Strip)  
GWH12NB-K3NNA2A/I(Membrana Decorative Strip)  
GWH12NB-K3NNA2A/I

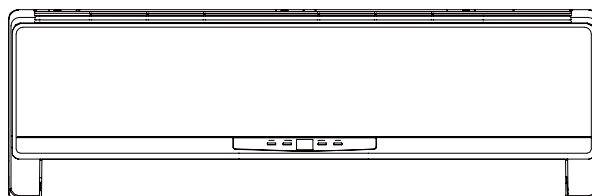

GWH12NB-K3NNC7C/I

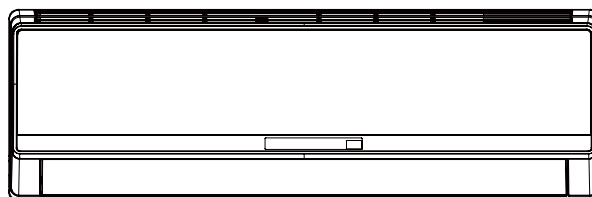

GWH07NA-K3NNB3A/I(Cold Plasma)  
GWH09NA-K3NNB3A/I(Cold Plasma)  
GWH09NA-K3NNB3C/I(Cold Plasma)

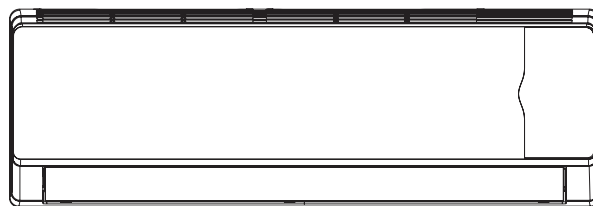

**Outdoor Unit:**

GWH07NA-K3NNB1A/O  
GWH09NB-K3NNE2A/O

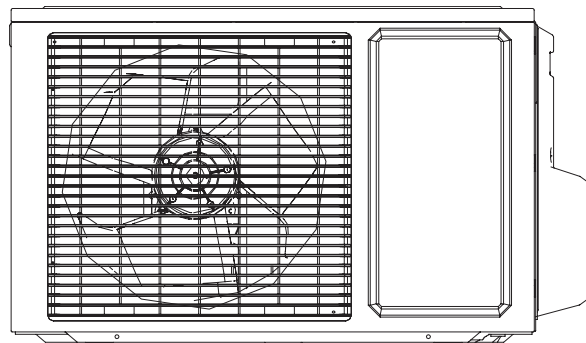

GWH09NA-K3NNB1A/O  
GWH09NA-K3NNB1C/O  
GWH12NB-K3NNB1A/O  
GWH12NB-K3NNB1C/O

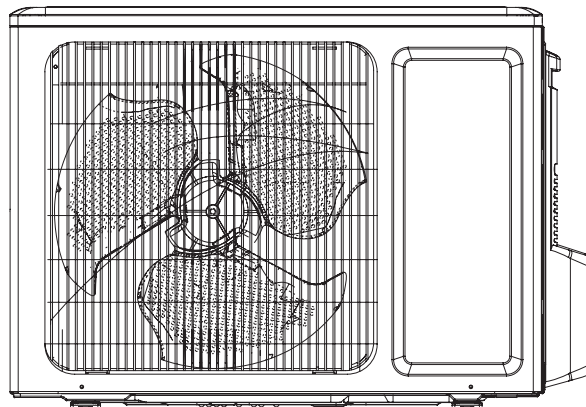

**Remote Controller:**

YX1F



# 1. Safety Precautions

Installing, starting up, and servicing air conditioner can be hazardous due to system pressure, electrical components, and equipment location, etc.

Only trained, qualified installers and service personnel are allowed to install, start-up, and service this equipment. Untrained personnel can perform basic maintenance functions such as cleaning coils. All other operations should be performed by trained service personnel.

When handling the equipment, observe precautions in the manual and on tags, stickers, and labels attached to the equipment. Follow all safety codes. Wear safety glasses and work gloves. Keep quenching cloth and fire extinguisher nearby when brazing.

Read the instructions thoroughly and follow all warnings or cautions in literature and attached to the unit. Consult local building codes and current editions of national as well as local electrical codes.

Recognize the following safety information:



**Warning** Incorrect handling could result in personal injury or death.



**Caution** Incorrect handling may result in minor injury, or damage to product or property.

- Make sure the outdoor unit is installed on a stable, level surface with no accumulation of snow, leaves, or trash beside.
- Make sure the ceiling/wall is strong enough to bear the weight of the unit.
- Make sure the noise of the outdoor unit does not disturb neighbors.
- Follow all the installation instructions to minimize the risk of damage from earthquakes, typhoons or strong winds.
- Avoid contact between refrigerant and fire as it generates poisonous gas.
- Apply specified refrigerant only. Never have it mixed with any other refrigerant. Never have air remain in the refrigerant line as it may lead to rupture and other hazards.
- Make sure no refrigerant gas is leaking out when installation is completed.
- Should there be refrigerant leakage, the density of refrigerant in the air shall in no way exceed its limited value, or it may lead to explosion.
- Keep your fingers and clothing away from any moving parts.
- Clear the site after installation. Make sure no foreign objects are left in the unit.
- Always ensure effective grounding for the unit.



## Warning

All electric work must be performed by a licensed technician according to local regulations and the instructions given in this manual.

- Before installing, modifying, or servicing system, main electrical disconnect switch must be in the OFF position. There may be more than 1 disconnect switch. Lock out and tag switch with a suitable warning label.
- Never supply power to the unit unless all wiring and tubing are completed, reconnected and checked.
- This system adopts highly dangerous electrical voltage. Incorrect connection or inadequate grounding can cause personal injury or death. Stick to the wiring diagram and all the instructions when wiring.
- Have the unit adequately grounded in accordance with local electrical codes.
- Have all wiring connected tightly. Loose connection may lead to overheating and a possible fire hazard.

All installation or repair work shall be performed by your dealer or a specialized subcontractor as there is the risk of fire, electric shock, explosion or injury.



## Caution

- Never install the unit in a place where a combustible gas might leak, or it may lead to fire or explosion.
- Make a proper provision against noise when the unit is installed at a telecommunication center or hospital.
- Provide an electric leak breaker when it is installed in a watery place.
- Never wash the unit with water.
- Handle unit transportation with care. The unit should not be carried by only one person if it is more than 20kg.
- Never touch the heat exchanger fins with bare hands.
- Never touch the compressor or refrigerant piping without wearing glove.
- Do not have the unit operate without air filter.
- Should any emergency occur, stop the unit and disconnect the power immediately.
- Properly insulate any tubing running inside the room to prevent the water from damaging the wall.

## 2. Specifications

### 2.1 Unit Specifications

Model			1.GWH07NA-K3NNA4A 2.GWH07NA-K3NNA8A 3.GWH07NA-K3NND2A 4.GWH07NA-K3NNB3A	1.GWH09NA-K3NNA2A 2.GWH09NA-K3NNA4A	
Product Code			1.CA16100161 2.CA17300300 3.CA149000101 4.CA138003503	1.CA18100193,CA18100191 2.CA16100173	
Power Supply	Rated Voltage	V ~	220-240	220-240	
	Rated Frequency	Hz	50	50	
	Phases		1	1	
Power Supply Mode			Indoor	Indoor	
Cooling Capacity		W	2200	2638	
Heating Capacity		W	2380	2814	
Cooling Power Input		W	685	821	
Heating Power Input		W	659	779	
Cooling Power Current		A	3.04	3.64	
Heating Power Current		A	2.92	3.46	
Rated Input		W	1060	1120	
Rated Current		A	4.7	4.97	
Air Flow Volume(SH/H/M/L/SL)		m <sup>3</sup> /h	400/350/310/280/-	400/350/310/280/-	
Dehumidifying Volume		L/h	0.6	0.8	
EER		W/W	3.21	3.21	
COP		W/W	3.61	3.61	
SEER		W/W	/	/	
HSPF		W/W	/	/	
Application Area		m <sup>2</sup>	10-16	12-18	
Indoor Unit	Model of indoor unit		GWH07NA-K3NNA4A/I GWH07NA-K3NNA8A/I GWH07NA-K3NND2A/I GWH07NA-K3NNB3A/I	1.GWH09NA-K3NNA2A/I 2.GWH09NA-K3NNA4A/I	
	Fan Type		Cross-flow	Cross-flow	
	Diameter Length(DXL)		mm	Φ85X532	Φ85X532
	Fan Motor Cooling Speed(SH/H/M/L/SL)		r/min	1350/1220/1100/1000/-	1350/1250/1140/1040/-
	Fan Motor Heating Speed(SH/H/M/L/SL)		r/min	1320/1220/1120/980/-	1350/1250/1140/1040/-
	Output of Fan Motor		W	10	10
	Fan Motor RLA		A	0.13	0.13
	Fan Motor Capacitor		μF	1	1
	Input of Heater		W	/	/
	Evaporator Form			Aluminum Fin-copper Tube	Aluminum Fin-copper Tube
	Pipe Diameter		mm	Φ7	Φ7
	Row-fin Gap		mm	2-1.5	2-1.5
	Coil Length (LXDXW)		mm	526X25.4X228.6	526X25.4X228.6
	Swing Motor Model			MP24AA	MP24AA
	Output of Swing Motor		W	1.5	1.5
	Fuse		A	3.15	3.15
	Sound Pressure Level (SH/H/M/L/SL)		dB (A)	40/37/35/32/-	40/37/35/32/-
	Sound Power Level (SH/H/M/L/SL)		dB (A)	50/47/45/42/-	50/47/45/42/-
	Dimension (WXHXD)		mm	730X255X174	730X255X174
	Dimension of Carton Box (LXWXH)		mm	790X245X325	790X245X325
Dimension of Package(LXWXH)		mm	793X248X340	793X248X340	
Net Weight		kg	8	8	
Gross Weight		kg	10.5	10.5	

Outdoor Unit	Model of Outdoor Unit		GWH07NA-K3NNB1A/O	GWH09NA-K3NNB1A/O
	Compressor Manufacturer/Trademark		Xi'an Qing'an Refrigeration Equipment Co.,Ltd./QINGAN	PANASONIC WANBAO COMPRESSOR (GUANGZHOU) Co.,LTD/ PANASONIC
	Compressor Model		YZG-A082Y2	5PS102EAA22
	Compressor Oil		RB68EP	FV50S or equivalent
	Compressor Type		Rotary	Rotary
	L.R.A.	A	17	20.9
	Compressor RLA	A	3.35	3.85/3.60
	Compressor Power Input	W	705	835/850
	Overload Protector		B135-140-241E	B160-150-241H
	Throttling Method		Capillary	Capillary
	Operation Temp	°C	16~30	16~30
	Ambient Temp (Cooling)	°C	18~43	18~43
	Ambient Temp (Heating)	°C	-7~24	-7~24
	Condenser Form		Aluminum Fin-copper Tube	Aluminum Fin-copper Tube
	Pipe Diameter	mm	Φ7	Φ9.52
	Rows-fin Gap	mm	2-1.4	1-1.4
	Coil Length (LXDXW)	mm	652X25.4X400.5	748X22X508
	Fan Motor Speed	rpm	950	830±30
	Output of Fan Motor	W	20	30
	Fan Motor RLA	A	0.37	0.37
	Fan Motor Capacitor	μF	1.5	2.5
	Air Flow Volume of Outdoor Unit	m <sup>3</sup> /h	1200	1600
	Fan Type		Axial-flow	Axial-flow
	Fan Diameter	mm	Φ320	Φ394.5
	Defrosting Method		Automatic Defrosting	Automatic Defrosting
	Climate Type		T1	T1
	Isolation		I	I
	Moisture Protection		IP24	IP24
	Permissible Excessive Operating Pressure for the Discharge Side	MPa	3.8	3.8
	Permissible Excessive Operating Pressure for the Suction Side	MPa	1.2	1.2
	Sound Pressure Level (H/M/L)	dB (A)	50/-/-	50/-/-
	Sound Power Level (H/M/L)	dB (A)	60/-/-	60/-/-
	Dimension (WXHXD)	mm	720X428X310	776X540X320
Dimension of Carton Box (LXWXH)	mm	765X350X475	820X355X580	
Dimension of Package(LXWXH)	mm	768X353X490	823X358X595	
Net Weight	kg	23.5	31	
Gross Weight	kg	26	34	
Refrigerant		R410A	R410A	
Refrigerant Charge	kg	0.76	0.76	
Connection Pipe	Length	m	5	5
	Gas Additional Charge	g/m	20	20
	Outer Diameter Liquid Pipe	mm	Φ6	Φ6
	Outer Diameter Gas Pipe	mm	Φ9.52	Φ12
	Max Distance Height	m	5	10
	Max Distance Length	m	15	15

The above data is subject to change without notice. Please refer to the nameplate of the unit.



Model			GWH09NA-K3NNA2C GWH09NA-K3NNB3C	GWH09NA-K3NNB3A	
Product Code			CA181006301 CA13800322	CA13800156	
Power Supply	Rated Voltage	V ~	220-240	220-240	
	Rated Frequency	Hz	50	50	
	Phases		1	1	
Power Supply Mode			Indoor	Indoor	
Cooling Capacity		W	2638	2638	
Heating Capacity		W	2814	2814	
Cooling Power Input		W	821	821	
Heating Power Input		W	779	779	
Cooling Power Current		A	3.64	3.64	
Heating Power Current		A	3.46	3.46	
Rated Input		W	1120	1120	
Rated Current		A	4.97	4.97	
Air Flow Volume(SH/H/M/L/SL)		m <sup>3</sup> /h	400/350/310/280/-	400/350/310/280/-	
Dehumidifying Volume		L/h	0.8	0.8	
EER		W/W	3.21	3.21	
COP		W/W	3.61	3.61	
SEER		W/W	/	/	
HSPF		W/W	/	/	
Application Area		m <sup>2</sup>	12-18	12-18	
Indoor Unit	Model of indoor unit		GWH09NA-K3NNA2C/I GWH09NA-K3NNB3C/I	GWH09NA-K3NNB3A/I	
	Fan Type		Cross-flow	Cross-flow	
	Diameter Length(DXL)		mm	Φ85X532	Φ85X532
	Fan Motor Cooling Speed(SH/H/M/L/SL)		r/min	1390/1280/1180/1080/-	1390/1280/1180/1080/-
	Fan Motor Heating Speed(SH/H/M/L/SL)		r/min	1350/1250/1140/1040/-	1350/1250/1140/1040/-
	Output of Fan Motor		W	10	10
	Fan Motor RLA		A	0.13	0.13
	Fan Motor Capacitor		μF	1	1
	Input of Heater		W	/	/
	Evaporator Form			Aluminum Fin-copper Tube	Aluminum Fin-copper Tube
	Pipe Diameter		mm	Φ7	Φ7
	Row-fin Gap		mm	2-1.5	2-1.5
	Coil Length (LXDXW)		mm	526X25.4X228.6	526X25.4X228.6
	Swing Motor Model			MP24AA	MP24AA
	Output of Swing Motor		W	1.5	1.5
	Fuse		A	3.15	3.15
	Sound Pressure Level (SH/H/M/L/SL)		dB (A)	40/37/35/32/-	40/37/35/32/-
	Sound Power Level (SH/H/M/L/SL)		dB (A)	50/47/45/42/-	50/47/45/42/-
	Dimension (WXHXD)		mm	730X255X174	730X255X174
	Dimension of Carton Box (LXWXH)		mm	790X245X325	790X245X325
Dimension of Package(LXWXH)		mm	793X248X340	793X248X340	
Net Weight		kg	8	8	
Gross Weight		kg	10.5	10.5	

Outdoor Unit	Model of Outdoor Unit		GWH09NA-K3NNB1C/O	GWH09NA-K3NNB1A/O
	Compressor Manufacturer/Trademark		ZHUHAI LANDA COMPRESSOR CO.,LTD. /GREE	PANASONIC WANBAO COMPRESSOR (GUANGZHOU) Co.,LTD/PANASONIC
	Compressor Model		QXA-B102C150	5PS102EAA22
	Compressor Oil		RB68EP	FV50S or equivalent
	Compressor Type		Rotary	Rotary
	L.R.A.	A	15	20.90
	Compressor RLA	A	3.9	3.85/3.60
	Compressor Power Input	W	850	835/850
	Overload Protector		Internal	B160-150-241H
	Throttling Method		Capillary	Capillary
	Operation Temp	°C	16~30	16~30
	Ambient Temp (Cooling)	°C	18~43	18~43
	Ambient Temp (Heating)	°C	-7~24	-7~24
	Condenser Form		Aluminum Fin-copper Tube	Aluminum Fin-copper Tube
	Pipe Diameter	mm	Φ7.94	Φ9.52
	Rows-fin Gap	mm	1-1.4	1-1.4
	Coil Length (LXDXW)	mm	730X19.05X506	748X22X508
	Fan Motor Speed	rpm	830±30	830±30
	Output of Fan Motor	W	30	30
	Fan Motor RLA	A	0.37	0.37
	Fan Motor Capacitor	μF	2.5	2.5
	Air Flow Volume of Outdoor Unit	m <sup>3</sup> /h	1600	1600
	Fan Type		Axial-flow	Axial-flow
	Fan Diameter	mm	Φ394.5	Φ394.5
	Defrosting Method		Automatic Defrosting	Automatic Defrosting
	Climate Type		T1	T1
	Isolation		I	I
	Moisture Protection		IP24	IP24
	Permissible Excessive Operating Pressure for the Discharge Side	MPa	3.8	3.8
	Permissible Excessive Operating Pressure for the Suction Side	MPa	1.2	1.2
	Sound Pressure Level (H/M/L)	dB (A)	50/-/-	50/-/-
	Sound Power Level (H/M/L)	dB (A)	60/-/-	60/-/-
	Dimension (WXHXD)	mm	776X540X320	776X540X320
Dimension of Carton Box (LXWXH)	mm	820X355X580	820X355X580	
Dimension of Package(LXWXH)	mm	823X358X595	823X358X605	
Net Weight	kg	31	31	
Gross Weight	kg	34	34	
Refrigerant		R410A	R410A	
Refrigerant Charge	kg	0.66	0.76	
Connection Pipe	Length	m	5	5
	Gas Additional Charge	g/m	20	20
	Outer Diameter Liquid Pipe	mm	Φ6	Φ6
	Outer Diameter Gas Pipe	mm	Φ9.52	Φ9.52
	Max Distance Height	m	10	10
	Max Distance Length	m	15	15

The above data is subject to change without notice. Please refer to the nameplate of the unit.

Model			GWH09NB-K3NNE2A	
Product Code			CA401002900	
Power Supply	Rated Voltage	V ~	220-240	
	Rated Frequency	Hz	50	
	Phases		1	
Power Supply Mode			Indoor	
Cooling Capacity		W	2638	
Heating Capacity		W	2814	
Cooling Power Input		W	821	
Heating Power Input		W	779	
Cooling Power Current		A	3.64	
Heating Power Current		A	3.46	
Rated Input		W	1050	
Rated Current		A	5.4	
Air Flow Volume(SH/H/M/L/SL)		m <sup>3</sup> /h	500/440/400/360/-	
Dehumidifying Volume		L/h	0.8	
EER		W/W	3.21	
COP		W/W	3.61	
SEER		W/W	/	
HSPF		W/W	/	
Application Area		m <sup>2</sup>	12-18	
Indoor Unit	Model of indoor unit		GWH09NB-K3NNE2A/I	
	Fan Type		Cross-flow	
	Diameter Length(DXL)		mm	Φ85X596
	Fan Motor Cooling Speed(SH/H/M/L/SL)		r/min	1260/1050/920/730/-
	Fan Motor Heating Speed(SH/H/M/L/SL)		r/min	1320/1200/1100/950/-
	Output of Fan Motor		W	10
	Fan Motor RLA		A	0.13
	Fan Motor Capacitor		μF	1
	Input of Heater		W	/
	Evaporator Form			Aluminum Fin-copper Tube
	Pipe Diameter		mm	Φ7
	Row-fin Gap		mm	2-1.5
	Coil Length (LXDXW)		mm	581X25.4X264
	Swing Motor Model			MP24AA
	Output of Swing Motor		W	1.5
	Fuse		A	3.15
	Sound Pressure Level (SH/H/M/L/SL)		dB (A)	39/36/33/30/-
	Sound Power Level (SH/H/M/L/SL)		dB (A)	49/46/43/40/-
	Dimension (WXHXD)		mm	790X265X170
	Dimension of Carton Box (LXWXH)		mm	870X248X355
	Dimension of Package(LXWXH)		mm	873X251X370
Net Weight		kg	9	
Gross Weight		kg	12	

Outdoor Unit	Model of Outdoor Unit		GWH09NB-K3NNE2A/O	
	Compressor Manufacturer/Trademark		ZHUHAI LANDA COMPRESSOR CO., LTD	
	Compressor Model		QXA-B102C130	
	Compressor Oil		RB68EP	
	Compressor Type		Rotary	
	L.R.A.	A		17
	Compressor RLA	A		3.9
	Compressor Power Input	W		850
	Overload Protector			UP3-00
	Throttling Method			Capillary
	Operation Temp	°C		16~30
	Ambient Temp (Cooling)	°C		18~43
	Ambient Temp (Heating)	°C		-7~24
	Condenser Form			Aluminum Fin-copper Tube
	Pipe Diameter	mm		Φ9.52
	Rows-fin Gap	mm		1-1.4
	Coil Length (LXD <sub>X</sub> W)	mm		666X222X406
	Fan Motor Speed	rpm		950
	Output of Fan Motor	W		20
	Fan Motor RLA	A		0.3
	Fan Motor Capacitor	μF		1.5
	Air Flow Volume of Outdoor Unit	m <sup>3</sup> /h		1200
	Fan Type			Axial-flow
	Fan Diameter	mm		Φ320
	Defrosting Method			Automatic Defrosting
	Climate Type			T1
	Isolation			I
	Moisture Protection			IP24
	Permissible Excessive Operating Pressure for the Discharge Side	MPa		4.3
	Permissible Excessive Operating Pressure for the Suction Side	MPa		2.5
	Sound Pressure Level (H/M/L)	dB (A)		50/-/-
	Sound Power Level (H/M/L)	dB (A)		60/-/-
	Dimension (WXHXD)	mm		720X428X310
Dimension of Carton Box (LXWXH)	mm		765X350X475	
Dimension of Package(LXWXH)	mm		768X353X490	
Net Weight	kg		26	
Gross Weight	kg		29	
Refrigerant			R410A	
Refrigerant Charge	kg		0.7	
Connection Pipe	Length	m	4	
	Gas Additional Charge	g/m	20	
	Outer Diameter Liquid Pipe	mm	Φ6	
	Outer Diameter Gas Pipe	mm	Φ9.52	
	Max Distance Height	m	10	
	Max Distance Length	m	15	

The above data is subject to change without notice. Please refer to the nameplate of the unit.

Model			GWH12NB-K3NNC7C	1.GWH12NB-K3NNA2A 2.GWH12NB-K3NNA4A	
Product Code			CA195004600	1.CA18100231,CA18100230 2.CA16100291	
Power Supply	Rated Voltage	V ~	220-240	220-240	
	Rated Frequency	Hz	50	50	
	Phases		1	1	
Power Supply Mode			Indoor	Indoor	
Cooling Capacity		W	3223	3223	
Heating Capacity		W	3516	3516	
Cooling Power Input		W	1004	1004	
Heating Power Input		W	973	973	
Cooling Power Current		A	4.45	4.45	
Heating Power Current		A	4.32	4.32	
Rated Input		W	1450	1450	
Rated Current		A	6.43	6.43	
Air Flow Volume(SH/H/M/L/SL)		m <sup>3</sup> /h	550/500/420/350/-	550/500/420/350/-	
Dehumidifying Volume		L/h	1.2	1.2	
EER		W/W	3.21	3.21	
COP		W/W	3.61	3.61	
SEER		W/W	/	/	
HSPF		W/W	/	/	
Application Area		m <sup>2</sup>	15-22	15-22	
Indoor Unit	Model of indoor unit		GWH12NB-K3NNC7C/I	1.GWH12NB-K3NNA2A/I 2.GWH12NB-K3NNA4A/I	
	Fan Type		Cross-flow	Cross-flow	
	Diameter Length(DXL)		mm	Φ85X596	Φ85X596
	Fan Motor Cooling Speed(SH/H/M/L/SL)		r/min	1350/1250/1100/950/-	1350/1250/1100/950/-
	Fan Motor Heating Speed(SH/H/M/L/SL)		r/min	1350/1250/1100/950/-	1350/1250/1100/950/-
	Output of Fan Motor		W	10	10
	Fan Motor RLA		A	0.13	0.13
	Fan Motor Capacitor		μF	1	1
	Input of Heater		W	/	/
	Evaporator Form			Aluminum Fin-copper Tube	Aluminum Fin-copper Tube
	Pipe Diameter		mm	Φ7	Φ7
	Row-fin Gap		mm	2-1.5	2-1.5
	Coil Length (LXDXW)		mm	581X25.4X264	581X25.4X264
	Swing Motor Model			MP24AA	MP24AA
	Output of Swing Motor		W	1.5	1.5
	Fuse		A	3.15	3.15
	Sound Pressure Level (SH/H/M/L/SL)		dB (A)	41/38/35/32/-	41/38/35/32/-
	Sound Power Level (SH/H/M/L/SL)		dB (A)	51/48/45/42/-	51/48/45/42/-
	Dimension (WXHXD)		mm	790X265X177	790X265X177
	Dimension of Carton Box (LXWXH)		mm	870X248X355	870X248X355
Dimension of Package(LXWXH)		mm	873X251X370	873X251X370	
Net Weight		kg	9	9	
Gross Weight		kg	12	12	

Outdoor Unit	Model of Outdoor Unit		GWH12NB-K3NNB1C/O	GWH12NB-K3NNB1A/O
	Compressor Manufacturer/Trademark		ZHUHAI LANDA COMPRESSOR CO. LTD. / GREE	ZHUHAI LANDA COMPRESSOR CO. LTD. / GREE
	Compressor Model		QXA-B120C150	QXA-B120C150
	Compressor Oil		RB68EP	RB68EP
	Compressor Type		Rotary	Rotary
	L.R.A.	A	23	23
	Compressor RLA	A	4.7	4.7
	Compressor Power Input	W	1020	1020
	Overload Protector		Internal	Internal
	Throttling Method		Capillary	Capillary
	Operation Temp	°C	16~30	16~30
	Ambient Temp (Cooling)	°C	18~43	18~43
	Ambient Temp (Heating)	°C	-7~24	-7~24
	Condenser Form		Aluminum Fin-copper Tube	Aluminum Fin-copper Tube
	Pipe Diameter	mm	Φ9.52	Φ9.52
	Rows-fin Gap	mm	1-1.4	1-1.4
	Coil Length (LXD <sub>X</sub> W)	mm	748X25.4X508	748X25.4X508
	Fan Motor Speed	rpm	770	770
	Output of Fan Motor	W	35	35
	Fan Motor RLA	A	0.35	0.52
	Fan Motor Capacitor	μF	2.5	2.5
	Air Flow Volume of Outdoor Unit	m <sup>3</sup> /h	1600	1600
	Fan Type		Axial-flow	Axial-flow
	Fan Diameter	mm	Φ394.5	Φ394.5
	Defrosting Method		Automatic Defrosting	Automatic Defrosting
	Climate Type		T1	T1
	Isolation		I	I
	Moisture Protection		IP24	IP24
	Permissible Excessive Operating Pressure for the Discharge Side	MPa	3.8	3.8
	Permissible Excessive Operating Pressure for the Suction Side	MPa	1.2	1.2
	Sound Pressure Level (H/M/L)	dB (A)	52/-/-	52/-/-
	Sound Power Level (H/M/L)	dB (A)	62/-/-	62/-/-
	Dimension (WXHXD)	mm	776X540X320	776X540X320
Dimension of Carton Box (LXWXH)	mm	820X355X580	820X355X580	
Dimension of Package(LXWXH)	mm	823X358X595	823X358X595	
Net Weight	kg	31	35	
Gross Weight	kg	35	40	
Refrigerant		R410A	R410A	
Refrigerant Charge	kg	0.84	0.84	
Connection Pipe	Length	m	5	5
	Gas Additional Charge	g/m	20	20
	Outer Diameter Liquid Pipe	mm	Φ6	Φ6
	Outer Diameter Gas Pipe	mm	Φ9.52	Φ12
	Max Distance Height	m	10	10
	Max Distance Length	m	20	20

The above data is subject to change without notice. Please refer to the nameplate of the unit.

## 2.2 Capacity Variation Ratio According to Temperature

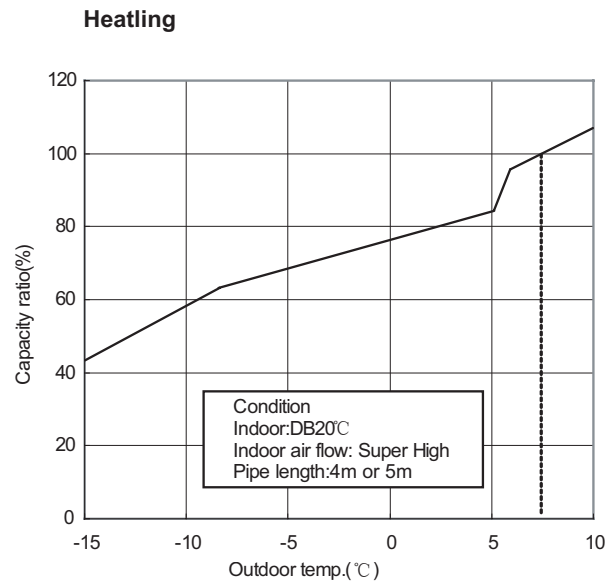
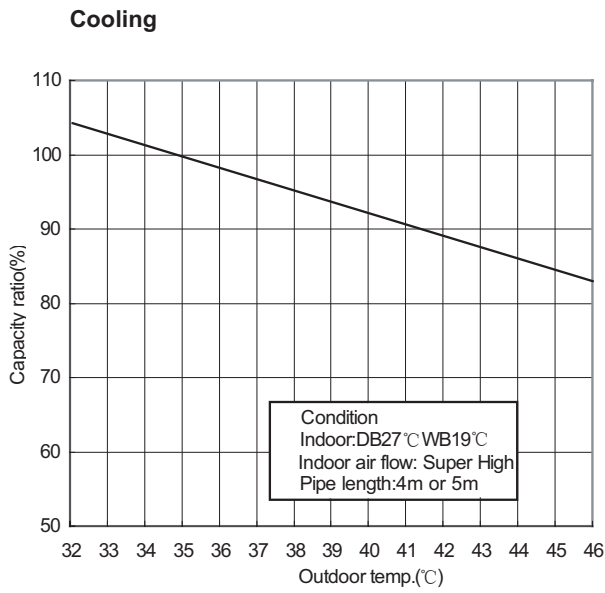

## 2.3 Operation Data

### Cooling

Temperature condition (°C)		Model name	Standard pressure	Heat exchanger pipe temp.		Indoor fan mode	Outdoor fan mode(rpm)
Indoor	Outdoor		P (MPa)	T1 (°C)	T2 (°C)		
27/19	35/24	07K GWH09NB-K3NNE2A	0.85~1.0	in:8~11 out:11~14	in:75~85 out:37~43	Super High	950
		09K					830±30
		12K					770

### Heating

Temperature condition (°C)		Model name	Standard pressure	Heat exchanger pipe temp.		Indoor fan mode	Outdoor fan mode(rpm)
Indoor	Outdoor		P (MPa)	T1 (°C)	T2 (°C)		
20/-	7/6	07K GWH09NB-K3NNE2A	2.5~2.8	in:75~85 out:37~43	in:1~3 out:2~5	Super High	950
		09K					830±30
		12K					770

T1: evaporator inlet and outlet pipe temperature;  
 T2: condenser inlet and outlet pipe temperature;  
 P: pressure of gas pipe connecting indoor and outdoor unit

### NOTES :

- (1) Measure surface temperature of heat exchanger pipe around center of heat exchanger path U bent. (Thermistor thermometer)
- (2) Connecting piping condition : 4 m or 5 m

### 3. Construction Views

#### 3.1 Indoor Unit

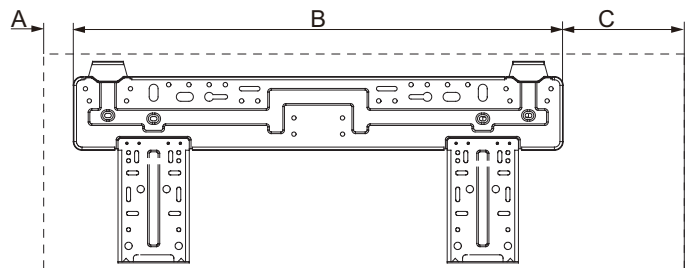
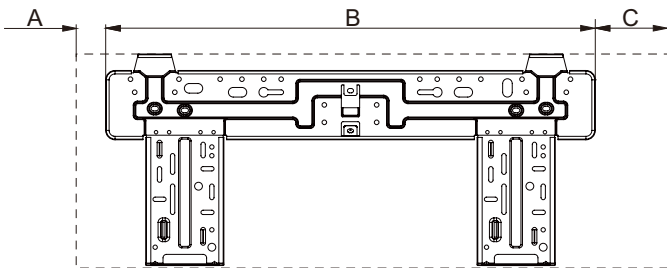
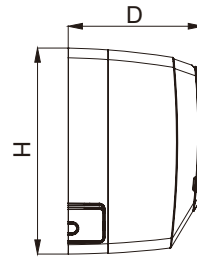
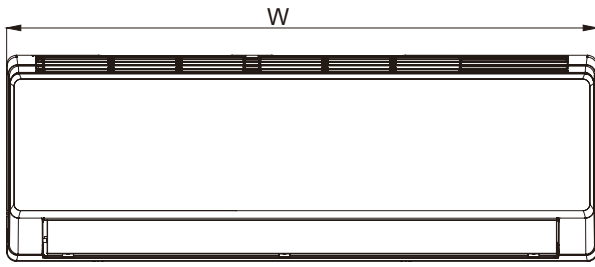

07/09K

12K  
GWH09NB-K3NNE2A

Models	W	H	D	A	B	C
07/09K	730	255	174	22	562	146
GWH09NB-K3NNE2A	790	265	177	35	605	150
12K						

Unit: mm



### 3.2 Outdoor Unit

Models: GWH07NA-K3NNB1A/O GWH09NB-K3NNE2A/O

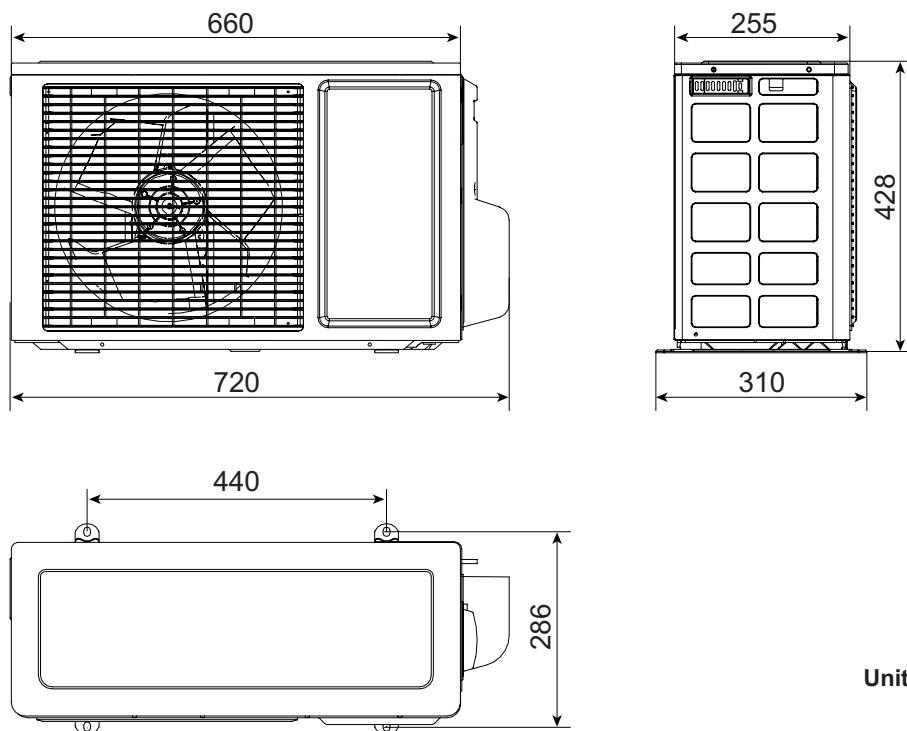

Unit: mm

Models: GWH09NA-K3NNB1A/O GWH09NA-K3NNB1C/O GWH12NB-K3NNB1A/O GWH12NB-K3NNB1C/O

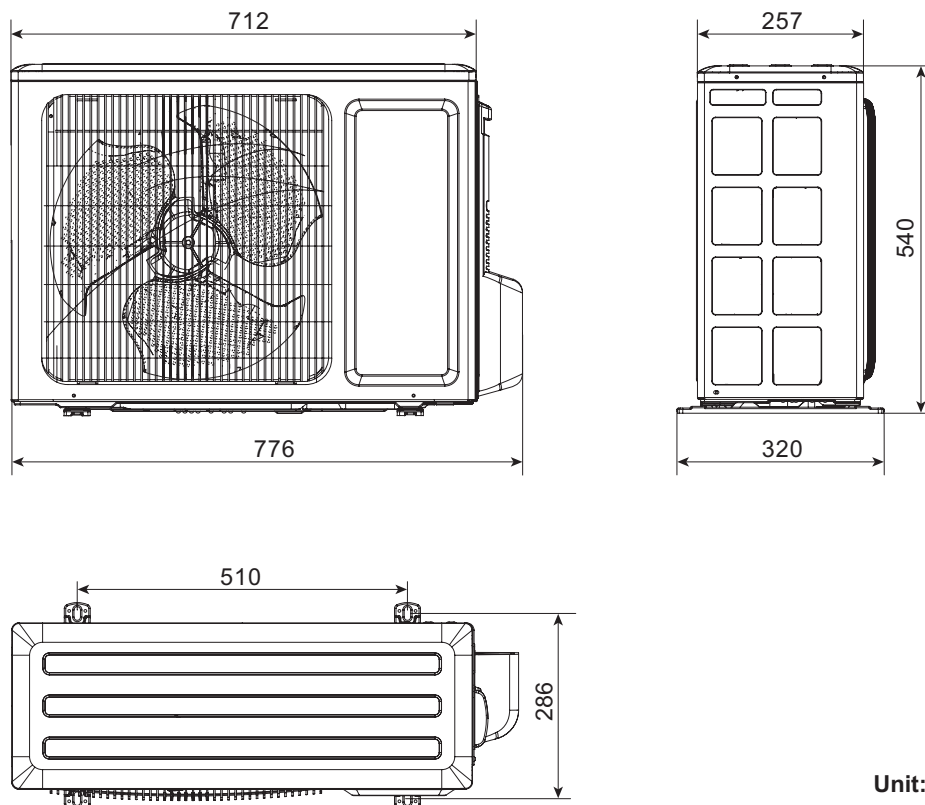

Unit: mm

## 4. Refrigerant System Diagram

- Cooling & Heating Models

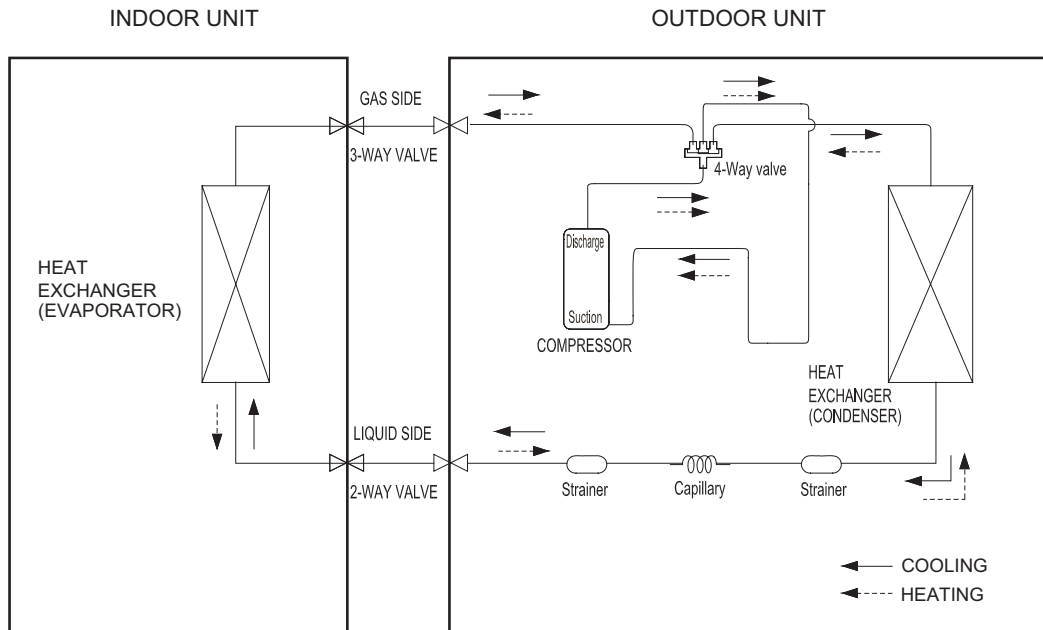

Refrigerant pipe diameter

Liquid :1/4" (6 mm)

Gas :3/8" (9.52 mm) (GWH07NA-K3NNA4A GWH07NA-K3NNA8A GWH07NA-K3NND2A GWH07NA-K3NNB3A GWH09NB-K3NNE2A GWH12NB-K3NNC7C GWH09NA-K3NNA2C GWH09NA-K3NNB3A GWH09NA-K3NNB3C)

Gas :1/2" (12 mm) (GWH09NA-K3NNA4A GWH09NA-K3NNA2A GWH12NB-K3NNA2A GWH12NB-K3NNA4A)

# 5. Schematic Diagram

## 5.1 Electrical Wiring

- Electrical Data

Symbol	Color symbol	Symbol	Color symbol
BU	BLUE	BN	BROWN
YE	YELLOW	BK	BLACK
RD	RED	YEGN	YELLOW GREEN
VT	VIOLET	Symbol	Part name
OG	ORANGE	⊕	PROTECTIVE
WH	WHITE		EARTH

- Indoor Unit

Models:GWH07NA-K3NNA4A/I(Cold Plasma) GWH09NA-K3NNA4A/I(Cold Plasma)  
 GWH07NA-K3NNB3A/I(Cold Plasma) GWH09NA-K3NNB3A/I(Cold Plasma)  
 GWH09NA-K3NNB3C/I(Cold Plasma)

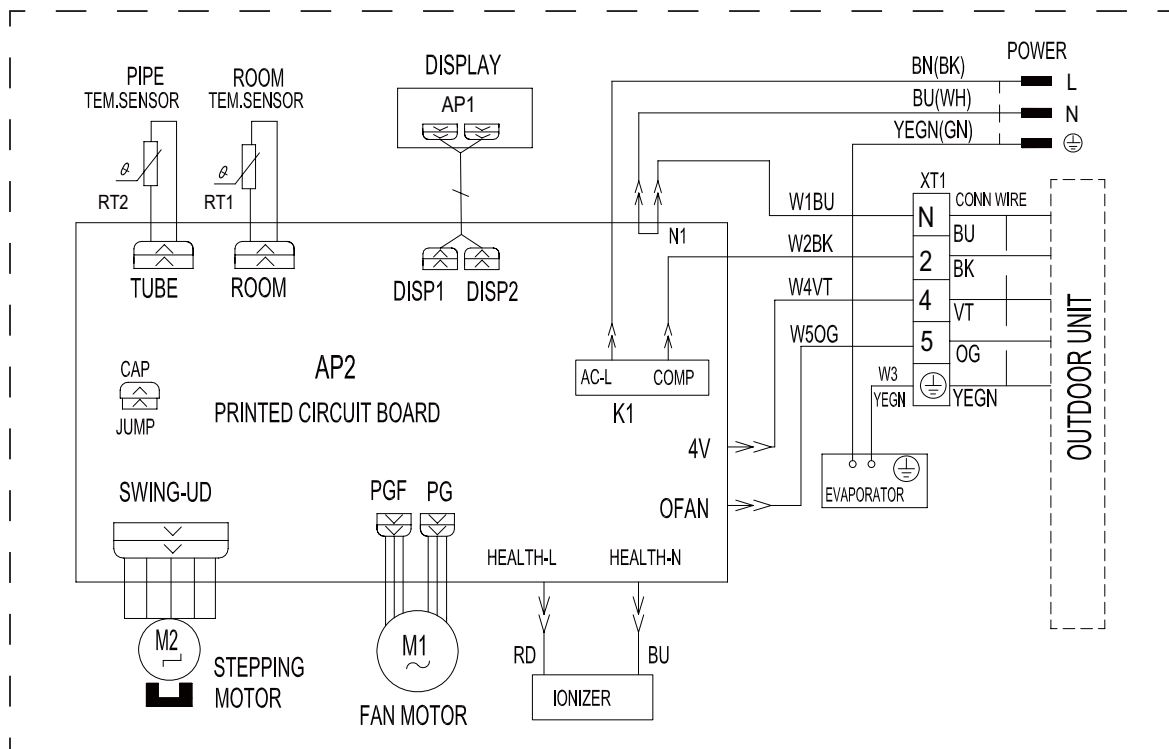

Models:GWH07NA-K3NND2A/I GWH09NA-K3NNA2A/I(Membrana Decorative Strip)  
 GWH07NA-K3NNA8A/I GWH09NA-K3NNA2A/I GWH09NA-K3NNA2C/I

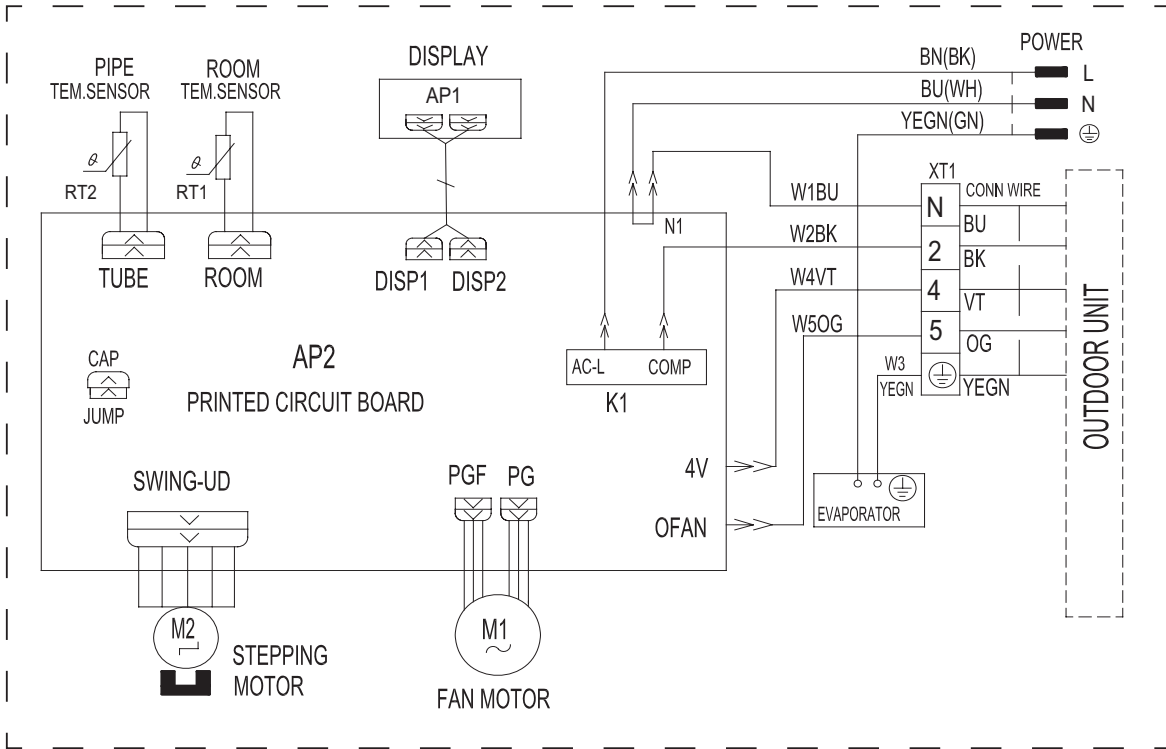

Model:GWH09NB-K3NNE2A/I

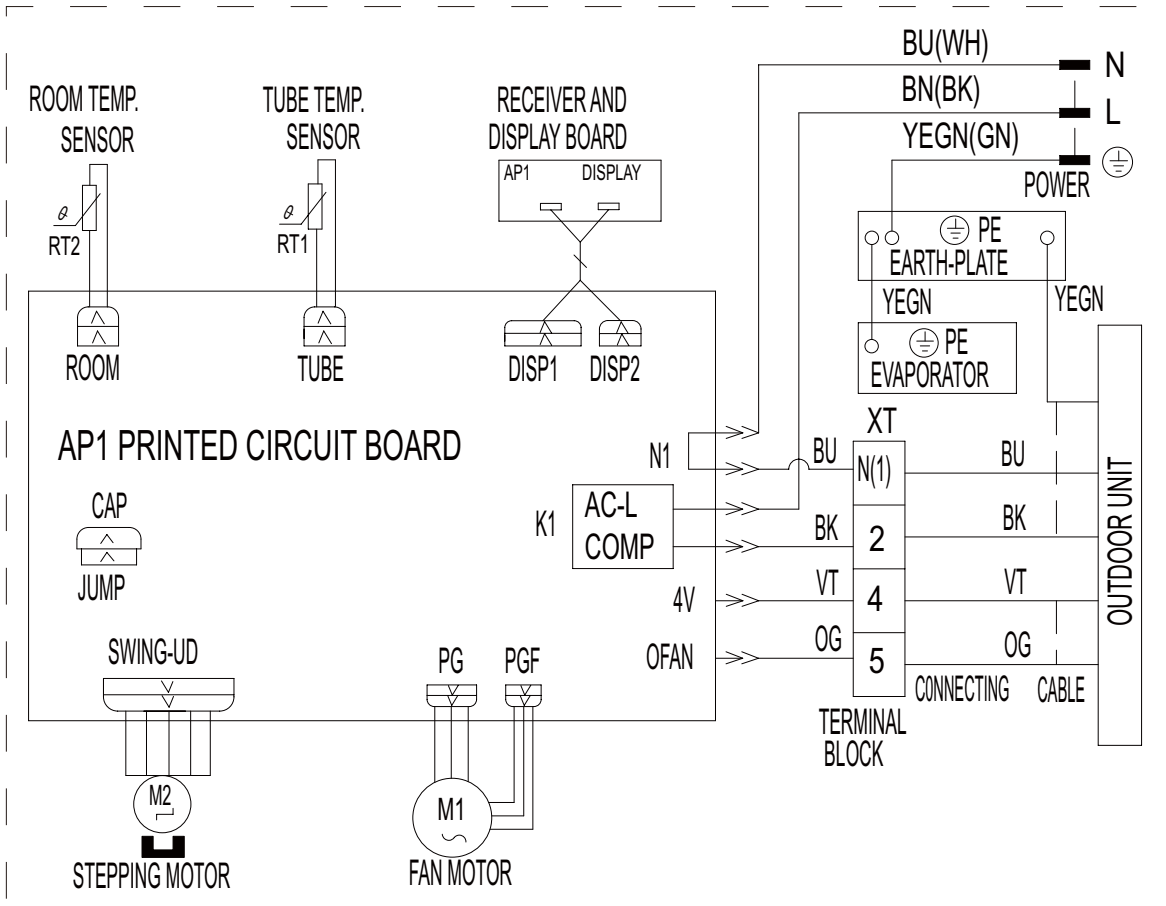

Models:GWH12NB-K3NNA2A/I(Membrana Decorative Strip) GWH12NB-K3NNA2A/I  
GWH12NB-K3NNC7C/I

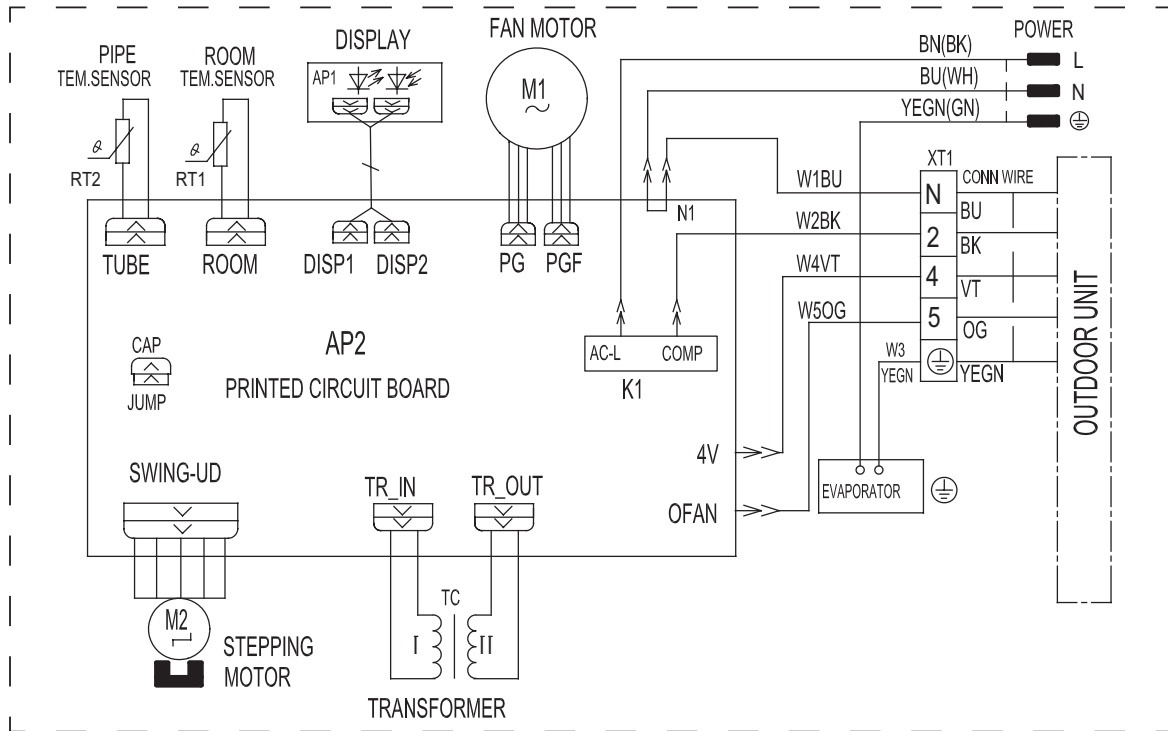

Model:GWH12NB-K3NNA4A/I(Cold Plasma)

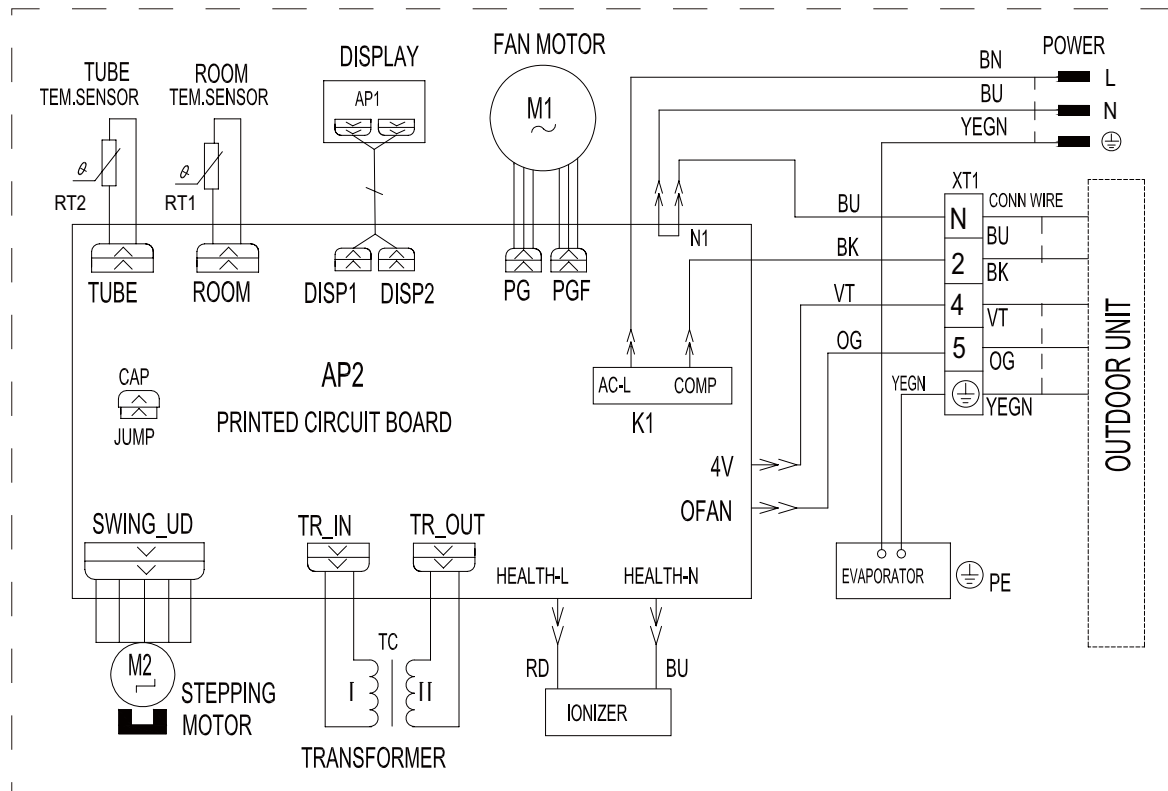

● Outdoor Unit

Models: GWH07NA-K3NNB1A/O GWH09NA-K3NNB1A/O

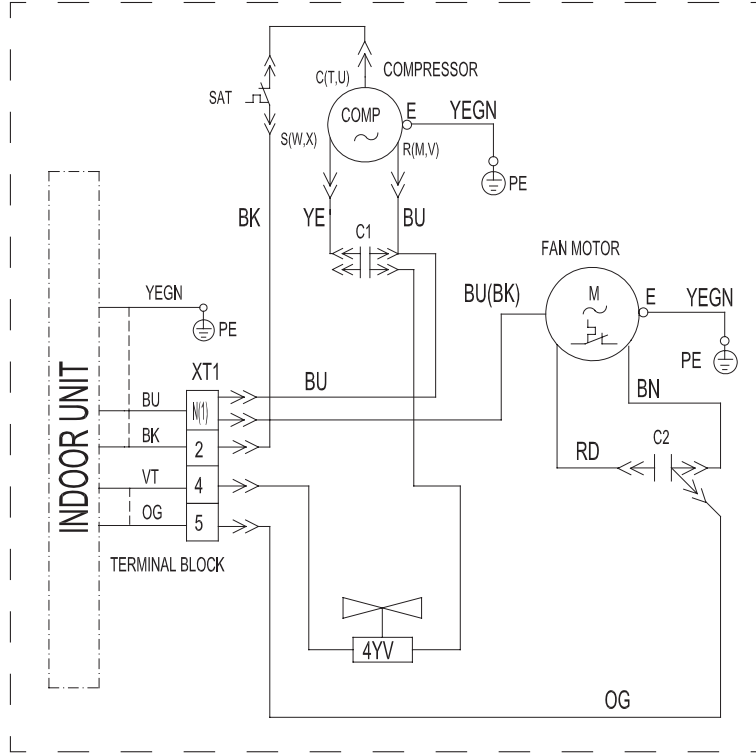

Model: GWH12NB-K3NNB1A/O

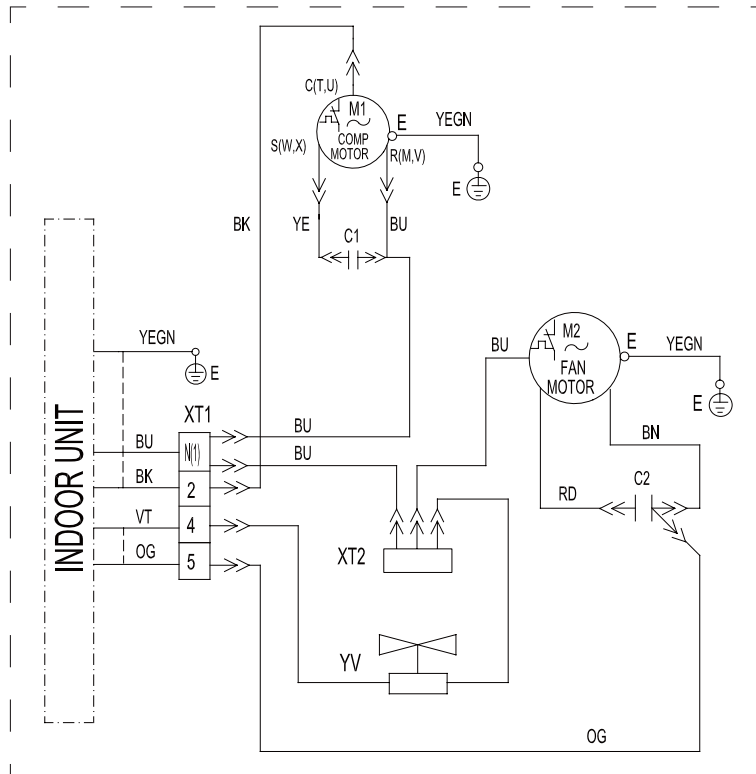

Models:GWH09NB-K3NNE2A/O GWH09NA-K3NNB1C/O GWH12NB-K3NNB1C/O

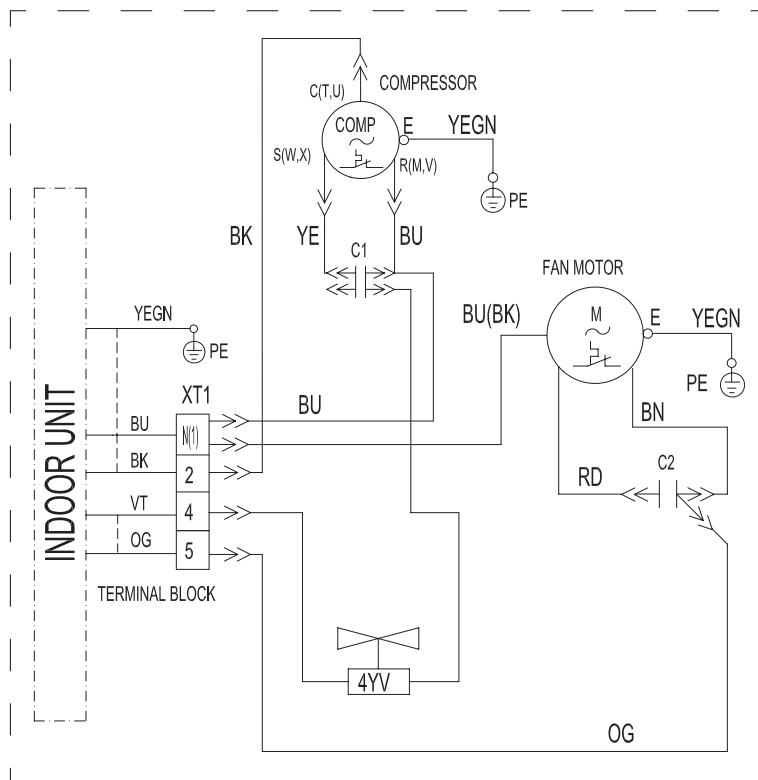

These circuit diagrams are subject to change without notice, please refer to the one supplied with the unit.

## 5.2 Printed Circuit Board

07/09K

● TOP VIEW

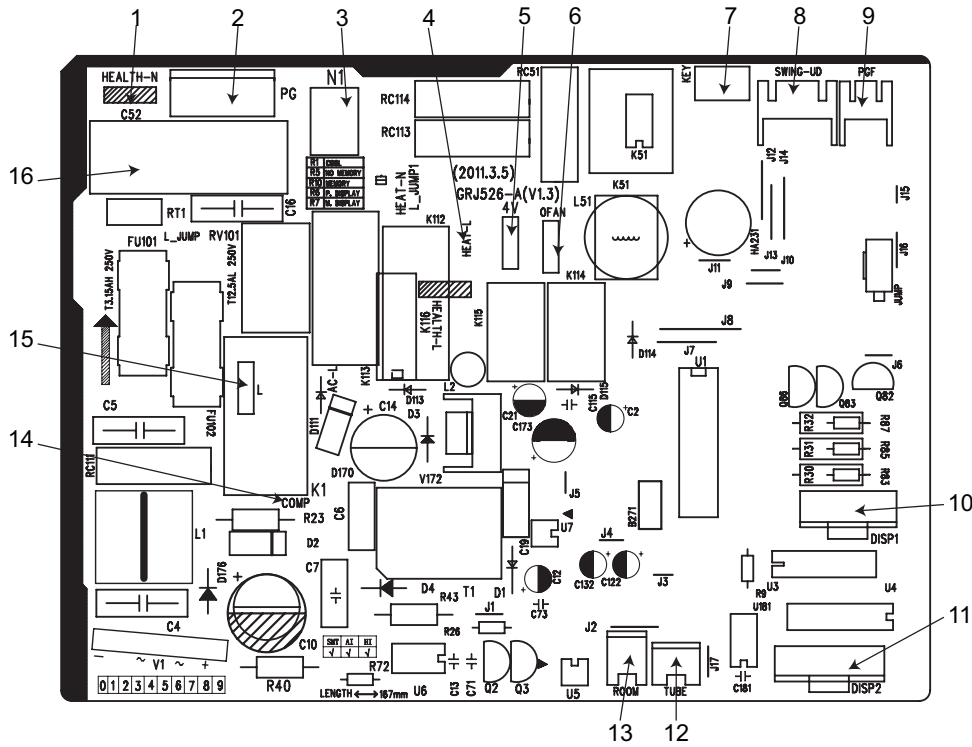

NO.	Part Name
1	Neutral wire of Health function
2	PG motor
3	Neutral wire
4	Live wire of Health function
5	4-way valve control terminal
6	Outdoor fan
7	Auto button
8	Up&down swing control terminal
9	Interface feedback from indoor fan
10	Display control terminal 1
11	Display control terminal 2
12	Interface of pipe temperature sensor
13	Interface of ambient temperature sensor
14	Compressor
15	Live wire
16	Fan capacitor

● BOTTOM VIEW

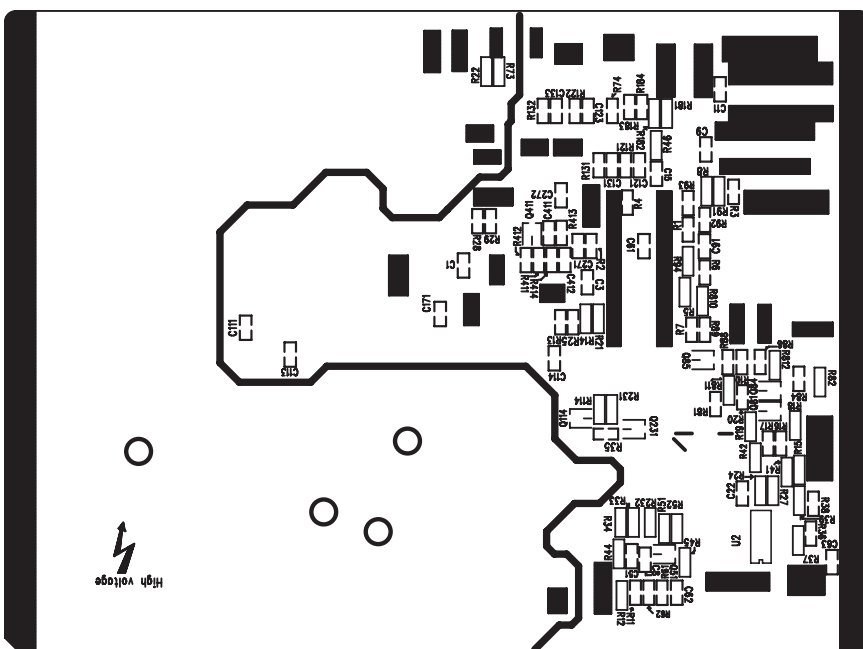



GWH09NB-K3NNE2A/I

●TOP VIEW

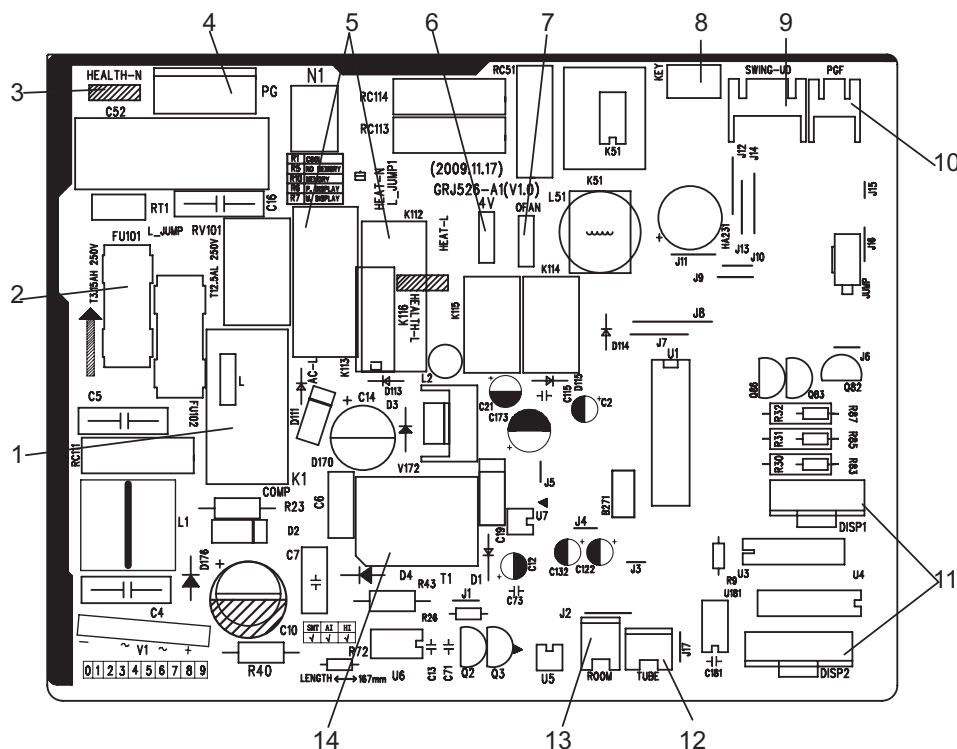

1	Compressor control relay K1
2	Fuse
3	Interface of health function neutral wire and control relay K116
4	Indoor fan control port
5	Auxiliary heating relay K113, K112
6	4-way valve control port and control relay K115
7	Outdoor fan control port and control relay K113
8	Auto button
9	Up & down swing control port
10	Indoor fan feedback interface
11	Display control port
12	Pipe temp sensor interface
13	Ambient temp sensor interface
14	High frequency transformer T1

●BOTTOM VIEW

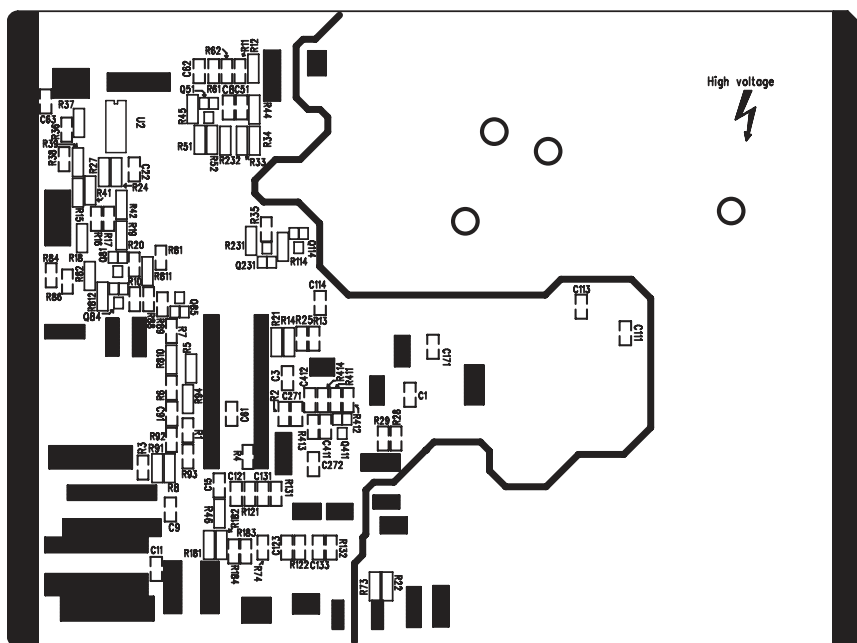

12K

● TOP VIEW

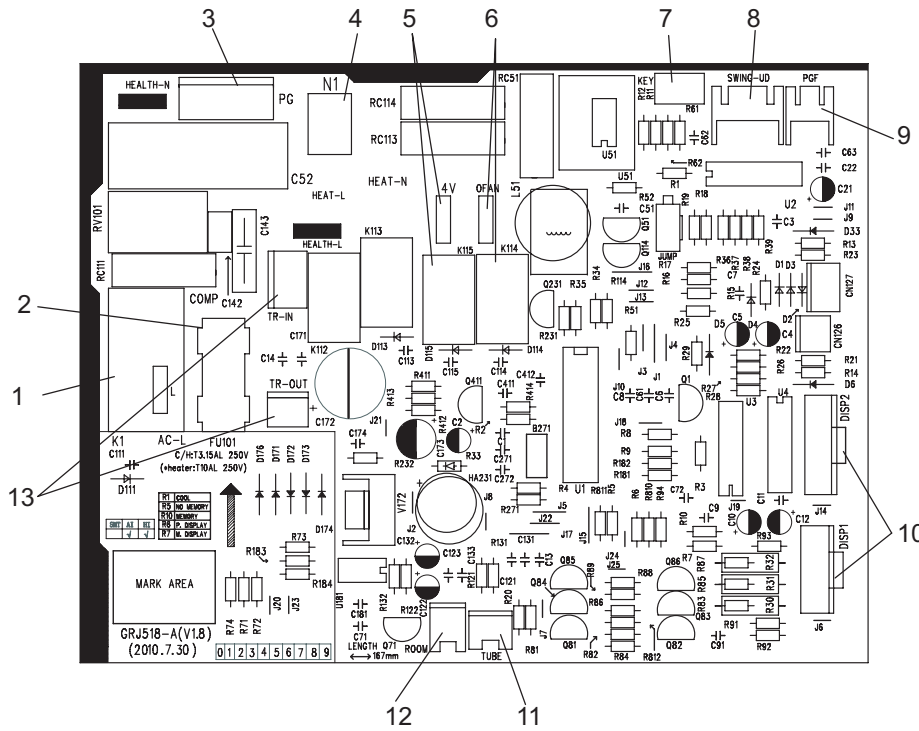

NO.	Part name
1	Compressor control relay
2	Protective tube
3	Indoor fan control terminal
4	Neutral wire terminal of power supply
5	4-way valve control terminal & control relay K115
6	Outdoor fan control terminal & control relay K114
7	Auto button
8	Up & down swing control terminal
9	Indoor fan feedback terminal
10	Display control terminal
11	Tube temperature sensor connector
12	Ambient temperature sensor connector
13	Linear transformer input terminal TR-IN & output terminal TR-OUT

● BOTTOM VIEW

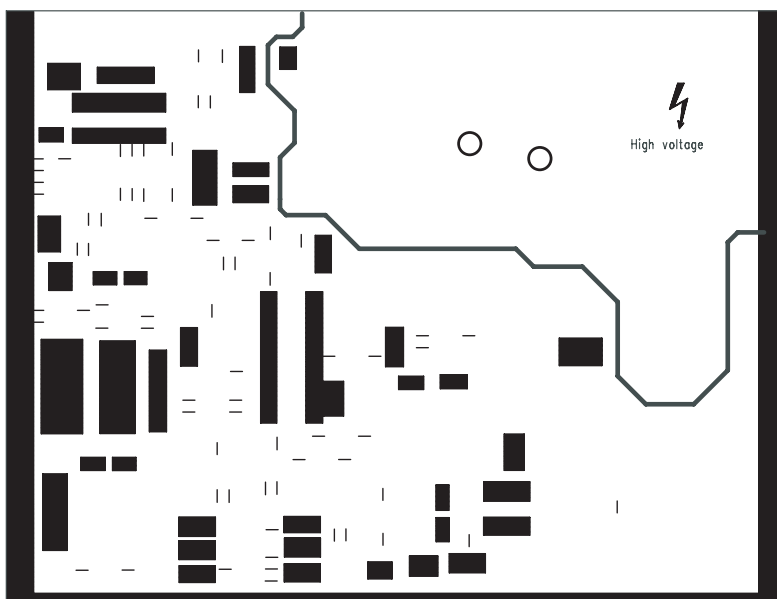

## 6. Function and Control

### 6.1 Remote Control Operations



- 1 **ON/OFF**  
Press it to start or stop operation.
- 2 **MODE**  
Press it to select operation mode(AUTO/COOL/DRY/FAN/HEAT).
- 3 **-** : Press it to decrease temperature setting.
- 4 **+** : Press it to increase temperature setting.
- 5 **FAN**  
Press it to set fan speed.
- 6 **SWING**  
Press it set swing angle.
- 7 **SLEEP**
- 8 **TIMER**  
Press it set auto-on/auto-off timer.

1 **ON/OFF** :  
Press this button to start the unit operation .Press this button again to stop the unit operation.

2 **MODE** :  
Each time you press the button,a mode is selected in a sequence that goes from AUTO,COOL,DRY, FAN,and HEAT\*, as the following:



\*Note:Only for models with heating function.

3 **-** :  
Press this button to decrease set temperature.Holding it down above 2 seconds rapidly decreases set temperature. In AUTO mode, set temperature is not adjustable.

4 **+** :  
Press this button to increase set temperature.Holding it down above 2 seconds rapidly increases set temperature. In AUTO mode, set temperature is not adjustable.

5 **FAN**:  
This button is used for setting Fan Speed in the sequence that goes from AUTO, , , to ,then back to Auto.

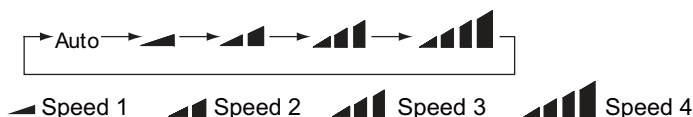

6 **SWING**:  
Press this key to activate or deactivate the swing.



**7 SLEEP:**

Press this button to go into the SLEEP operation mode. Press it again to cancel. This function is available in COOL , HEAT (Only for models with heating function) or DRY mode to maintain the most comfortable temperature for you.

**8 TIMER:**

Press this button to initiate auto-on/auto-off timer. To cancel auto-timer program, press this button twice.

**9 Combination of "+" and "-" buttons: About lock**

Press "+" and "-" buttons simultaneously to lock or unlock the keypad. If the remote controller is locked ,  is displayed. In this case, pressing any button,  blinks three times.

**10 Combination of "MODE " and "-" buttons: About switch between fahrenheit and cennigrade**

At unit OFF , press "MODE " and "-" buttons simultaneously to switch between °C and °F.

**11 Combination of "+" and "FAN" buttons:About Lamp**

Under switch-on or switch-off state, you may hold "+" and "FAN" buttons simultaneously for 3 seconds to set the lamp on or off and send the code. After being energized, the lamp is defaulted on.

## Replacement of Batteries

- 1.Remove the battery cover plate from the rear of the remote controller. (As shown in the figure)
- 2.Take out the old batteries.
- 3.Insert two new AAA1.5V dry batteries, and pay attention to the polarity.
4. Close the battery cover plate.

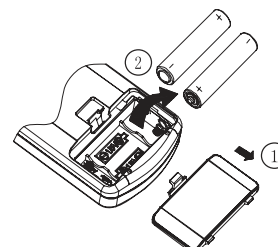

Fig.1

**★ Notes:**

- When replacing the batteries, do not use old or different types of batteries otherwise, it may cause malfunction.
- If the remote controller will not be used for a long time, please remove batteries to prevent batteries from leaking.
- The operation should be performed in its receiving range.
- It should be kept 1m away from the TV set or stereo sound sets.
- If the remote controller does not operate normally, please take the batteries out and replace them after 30 seconds. If still not operating properly,replace the batteries.

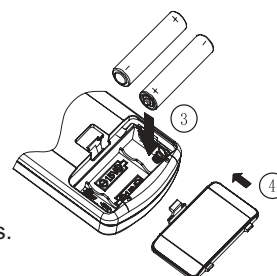

Fig.2

## 6.2 Description of Each Control Operation

### 1 Temperature Parameters

- ◆ Indoor preset temperature ( $T_{\text{preset}}$ )
- ◆ Indoor ambient temperature ( $T_{\text{amb.}}$ )

**2 Basic functions** (The temperature in this manual is expressed by Centigrade. If Fahrenheit, is used, the switchover between them is  $T_f = T_c \times 1.8 + 32$ .)

Once the unit is energized, the compressor shall never be restarted except 3mins interval at least. For the first energization, if the unit is at off status before power failure, the compressor can be restarted without 3-min delay. But if the unit is at on status before power failure, the compressor shall be restarted with 3mins delay. Once the compressor is started up, the compressor won't stop running within 6mins with the change of room temperature.

#### (1) Cooling mode

##### ① Cooling conditions and process

When  $T_{\text{amb.}} \geq T_{\text{preset}} + 1^\circ\text{C}$ , the unit starts cooling operation. In this case, the compressor and the outdoor fan operate and the indoor fan operates at set speed.

When  $T_{\text{amb.}} \leq T_{\text{preset}} - 1^\circ\text{C}$ , the compressor and the outdoor fan stop while the indoor fan runs at set speed.

When  $T_{\text{preset}} - 1^\circ\text{C} < T_{\text{amb.}} < T_{\text{preset}} + 1^\circ\text{C}$ , the unit will maintain its previous running state.

In cooling mode, the four-way valve is de-energized; temperature setting range is  $16 \sim 30^\circ\text{C}$ ; the indoor unit displays operation icon, cooling icon and set temperature.

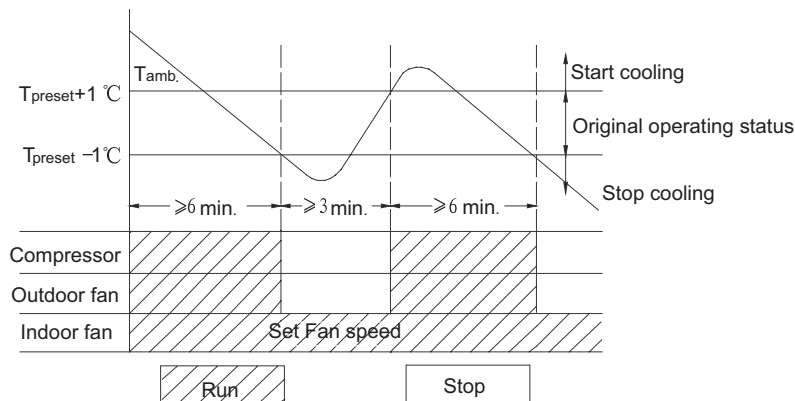

##### ② Protection Functions

###### ◆ Freeze protection

If the system is under freeze protection, the compressor and the outdoor fan stop operation, and the indoor fan operates at set speed. If freeze protection is eliminated and the compressor has been out of operation for 3 minutes, the unit will resume its previous running state.

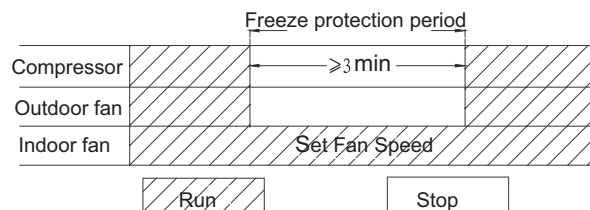

(2) Dry Mode

① Dry Conditions and Process

When  $T_{amb.} > T_{preset} + 2^{\circ}C$ , the unit will run in dry and cooling mode, in that case the compressor and outdoor fan will run and the indoor fan will run at low speed.

When  $T_{preset} - 2^{\circ}C \leq T_{amb.} \leq T_{preset} + 2^{\circ}C$ , the unit will run in dry mode, in that case, the indoor fan will run at low speed, the compressor and the outdoor fan will be stopped in 6 min. After 4 min, the compressor and the outdoor fan will be restarted. Dry process is cycled as the above.

When  $T_{amb.} < T_{preset} - 2^{\circ}C$ , the compressor and the outdoor fan will stop working and the indoor fan will run at low speed.

In this mode, the four-way valve is de-energized, and setting temperature range is between 16~30°C. The displayer will display running and drying icons and setting temperature.

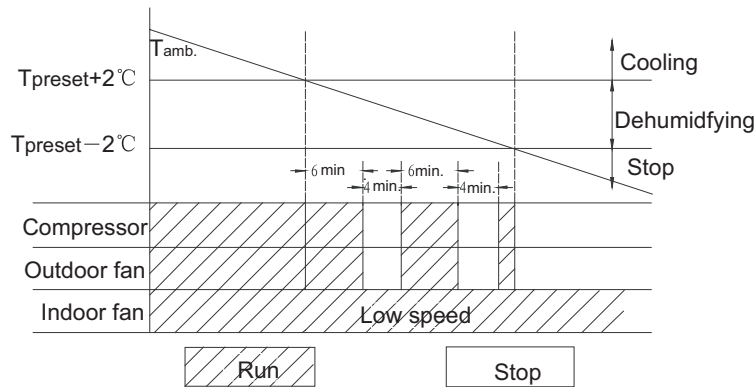

② Protection

◆ Freeze protection

If freeze protection of the system is detected in dry and cooling mode, the compressor and the outdoor fan will stop running and the indoor fan will run at low speed. When the freeze protection is released and the compressor has been stopped for 3 min, the complete unit will resume its previous running state. Upon the condition that the compressor runs for 6 min and stops for 4 min is met and freeze protection is detected, the compressor and the outdoor fan will stop running and the indoor fan will run at low speed. When the freeze protection is released and the compressor has been stopped for 4 min, the complete unit will resume its previous running state.

③ Other protection

Other protections are the same as those in cooling mode.

(3) Heating mode

① Heating conditions and process

When  $T_{amb.} \leq T_{preset} + 2^{\circ}C$ , the unit will run in heating mode, in that case, the four-way valve, the compressor and the outdoor fan will run simultaneously. The indoor fan will delay at most 2mins to run. The indoor fan will run 2 mins delayed at most.

When  $T_{amb} \geq T_{preset} + 4^{\circ}C$ , the compressor and the outdoor fan will stop and the four-way valve will remain energized (keep energizing) and the indoor fan will blow residual heat.

When  $T_{preset} + 2^{\circ}C < T_{amb.} < T_{preset} + 4^{\circ}C$ , the unit will maintain its previous running state.

Under this mode, the four-way valve is energized, and setting temperature range is 16~30°C. The displayer will display running and heating icons and setting temperature.

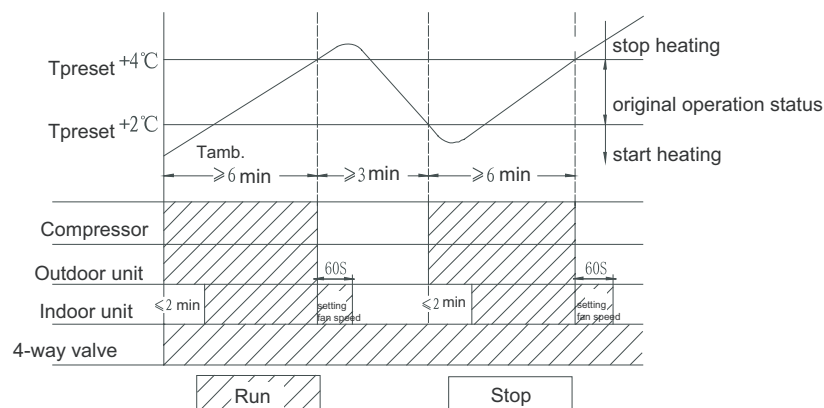

## ②Defrosting Conditions and Process

The unit with intelligent defrosting function can defrost according to frosting conditions. Dual8 displays H1.

## ③Protection Function

### ◆High Temp Resistance Protection

If it is detected that the evaporator tube temperature is superheating, the outdoor fan will stop working. When the tube temperature resumes to normal condition, the outdoor fan will resume running.

### ◆Noise Silencing Protection

If the unit is stopped by pressing ON/OFF or during switchover of modes, the reversing valve will be stopped after 2 min.

## (4)Fan mode

In this mode, indoor fan runs at setting speed, and the compressor, the outdoor fan, the four-way valve and the electric heating tube will stop running.

In this mode, temperature setting range is 16~30°C. Displayer displays running icons and the setting temperature.

## (5)Auto Mode

In this mode, the air conditioner will automatically select its running mode (cooling, heating or fan) with the change of ambient temperature. The displayer will display the running icons, actual running mode icon and setting temperature. There is 30s delay protection for mode switching. Protection functions are the same as those in any other mode.

## 3 Other Control

### (1)Timer function

The mainboard combines general timer and clock timer functions. Timer functions are selected by equipping remote controller with different functions.

#### ①General Timer:

Timer ON can be set under off state of unit. If timer ON reaches, the controller will run under previous setting mode. Timing interval is 0.5hr and the setting range is 0.5-24hr.

Timer OFF can be set under on state of unit. If timer OFF reaches, the unit is turned off. Timing interval is 0.5hr within the range of 0.5-24hr.

#### ②Clock Timer:

If timer on is set under running state of unit, the system will continue running. If timer on is set under off state of unit, the system will run in presetting mode when timer on reaches.

If timer off is set under off state of unit, the system will keep standby state. If timer off is set under on state of unit, the system will stop running when timer off reaches.

#### Timer Change:

If the system is under timer state, the unit can be turned on/off by ON/OFF button of remote controller. Timing can also be reset and then the system runs according to the final setting.

If timer on and timer off is set at the same time under running state of system, the system will keep present running state till timer off reaches and then it will stop running.

If timer on and timer off are set at the same time under off state of system, the system will keep stopping till timer on reaches and then it will start running.

In the future, the system will run in presetting mode when timer on reaches and stop when timer off reaches every day. If timer on and timer off have the same setting, timer off is prevails.

### (2)Auto Button

If press this button, the system will run in auto mode, and the indoor fan motor will run at auto speed; meanwhile, the swing motor will be running. Repress this button to turn off the unit.

### (3)Buzzer

When the controller is energized or receives any command or signal from the buttons or the remote controller, the buzzer will give out a beep.

### (4)Sleep Function

Choose the sleeping curve according to the preset temperature.

### (5)Turbo Function

This function can be set in cooling or heating mode.

(6)Dry Function

This function can be set in cooling or dry mode.

(7)Automatic Control of Fan Speed

In this mode, the indoor fan will automatically select high, medium or low speed with the change of ambient temperature.

(8)Up & Down Swing

After energization, up & down swing motor will rotate guide louver anticlockwise to position 0 to close air outlet.

After turning on the unit, if swing function has not been set, up & down guide louver will clockwise turn to position D in heating mode, or clockwise turn to level position L in other modes.

If the unit is turned on with swing function setting, the guide louver will swing between W and D. There are 7 kinds of swing states of guide louver: There are position L, A, B, C, D, and it swings and stops between L and D ( angle between L and D is equiangular).

Upon stop of unit, the guide louver will close to position O. Swing action is valid only when swing command is set and indoor fan is running.

Note: If the position is set between L and B, A and C or B and D by remote controller, the guide louver will swing between L and D.

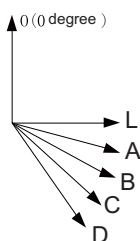

(9)Display

①Running icon and Mode icon

Upon energization, the unit will display all icons. Under standby state, running indicating icon is displayed in red. If the unit is started by remote controller, running indicating icon gives off light; Meanwhile, the present setting running mode icon will be displayed(mode LED: cooling, heating and dry mode). If the light button is turned off, all icons display will be closed.

②Dual-8 Display

After starting the unit for the first time, the nixie tube will display present setting temperature in default (16-30°C) the nixie tube will default to display the preset temperature. When displaying setting temperature signal is received, the nixie tube will display setting temp. If displaying ambient temperature signal is received, the nixie tube will display present indoor ambient temperature. If other states are set by remote controller, the display will keep previous. If remote controller receives valid signal during displaying ambient temperature, ambient temperature will be displayed after setting temperature is displayed for 5s. F1 is displayed for ambient temperature sensor malfunction, F2 for tube temp sensor malfunction of indoor unit and C5 for jumper cap has malfunction.

Some models: The remote controller will display present setting temp when this display is set. The controller will display ambient temp for 5s and then setting temp only when indoor ambient temp displaying state is switched from other displaying states by remote controller.

(10)Locked protection to PG motor

When starting the fan, if motor's rotational speed is slow for a period of time, the unit will display Locked and stop running to avoid auto protection for motor. If the unit is on currently, error code H6 will be displayed by the dual-8 nixie tube. If the unit is off currently, this locked malfunction information won't be displayed.

(11)Power-off memory

Memory content includes mode, up&down swing, light, setting temp and setting fan speed.

Upon power failure, the unit after power recovery will automatically start to run according to memory content. The system, last remote-control command without timer setting, will memorize the last remote-control signal and run according to it. If the last remote controller command has general timer function and the system is de-energized before setting time, the system will memorize the last timer function in remote controller command after re-energization and time will be recalculated. If there is function in the last remote controller command but setting time has reached, the system will act as timer on/off setting before de-energization. After re-energization, the system memorizes the running states before power failure without timer action.

Clock timer can not be memorized.



## 7. Installation Manual

### 7.1 Notices for Installation

#### Important Notices

- 1.The unit installation work must be done by qualified personnel according to the local rules and this manual.
- 2.Before installing, please contact with local authorized maintenance center, if unit is not installed by the authorized maintenance center, the malfunction may not solved, due to discommodious contacts.
- 3.When removing the unit to the other place, please firstly contact with the authorized Maintenance Center in the local area.
- 4.the appliance must be positioned so that the plug is accessible
- 5.After pull out the power plug then make the appliance operation again,to avoid the icing of outdoor unit damage axial flow fan,should electrify the appliance but not operation for 4 hours for warm-up purpose.

#### 7.1.1 Installation Site Instructions

Install in the following place may cause malfunction. If it is unavoidable contact withservice center please:

- strong heat sources, vapours, flammable gas or volatile liquids are emitted.
- high-frequency electro-magnetic waves are generated by radio equipment,welders and medical equipment.
- salt-laden air prevails (such as close to coastal areas).
- the air is contaminated with industrial vapours and oils.
- the air contains sulphures gas such as in hot spring zones.
- corrosion or poor air quality exists.

#### 7.1.2 Installation Site of Indoor Unit

- 1.The air inlet and outlet should be away from the obstructions. Ensure the air can be blown through the whole room.
- 2.Select a site where the condensate can be easily drained out, and where it is easily connected to outdoor unit.
- 3.Select a place where it is out of reach of children.
- 4.Select a place where the wall is strong enough to withstand the full weight and vibration of the unit.
- 5.Be sure to leave enough space to allow access for routine maintenance. The installation site should be 250cm or more above the floor.
- 6.Select a place about 1m or more away from TV set or any other electric appliance.
- 7.Select a place where the filter can be easily taken out.
- 8.Make sure that the indoor unit is installed in accordance with installation dimension instructions.
- 9.Do not use the unit in the laundry or by swimming pool etc.

#### 7.1.3 Installation Site of Outdoor Unit

- 1.Select a site where noise and outflow air emitted by the unit will not annoy neighbors.
- 2.Select a site where there is sufficient ventilation.
- 3.Select a site where there is no obstruction blocking the inlet and outlet.
- 4.The site should be able to withstand the full weight and vibration.
- 5.Select a dry place, but do not expose the unit to direct sunlight or strong wind.
- 6.Make sure that the outdoor unit is installed in accordance with the installation instructions, and is convenient for maintenance and repair.
- 7.The height difference between indoor and outdoor units is within Xm and the length of the connecting tubing does not exceed Ym.

Model	X	Y
07K	5	15
09K	10	15
12K	10	20

8. Select a place where it is out of reach of children.
9. Select a place where the unit does not have negative impact on pedestrians or on the city.

#### 7.1.4 Safety Precautions for Electric Appliances

1. A dedicated power supply circuit should be used in accordance with local electrical safety regulations.
2. Don't drag the power cord with excessive force.
3. The unit should be reliably earthed and connected to an exclusive earth device by the professionals.
4. The air switch must have the functions of magnetic tripping and heat tripping to prevent short circuit and overload.
5. The minimum distance between the unit and combustive surface is 1.5m.
6. The appliance shall be installed in accordance with national wiring regulations.
7. An all-pole disconnection switch with a contact separation of at least 3mm in all poles should be connected in fixed wiring.

Note:

- Make sure the live wire, neutral wire and earth wire in the family power socket are properly connected.
- There should be reliable circuit in the diagram. Inadequate or incorrect electrical connections may cause electric shock or fire.

#### 7.1.5 Earthing Requirements

1. Air conditioner is type I electric appliance. Please ensure that the unit is reliably earthed.
2. The yellow-green wire in air conditioner is the earthing wire which can not be used for other purposes. Improper earthing may cause electric shock.
3. The earth resistance should accord to the national criterion.
4. The power must have reliable earthing terminal. Please do not connect the earthing wire with the following:  
① Water pipe ② Gas pipe ③ Contamination pipe ④ Other place that professional personnel consider is unreliable
5. The model and rated values of fuses should accord with the silk print on fuse cover or related PCB.

## 7.2 Installation Dimension Diagram

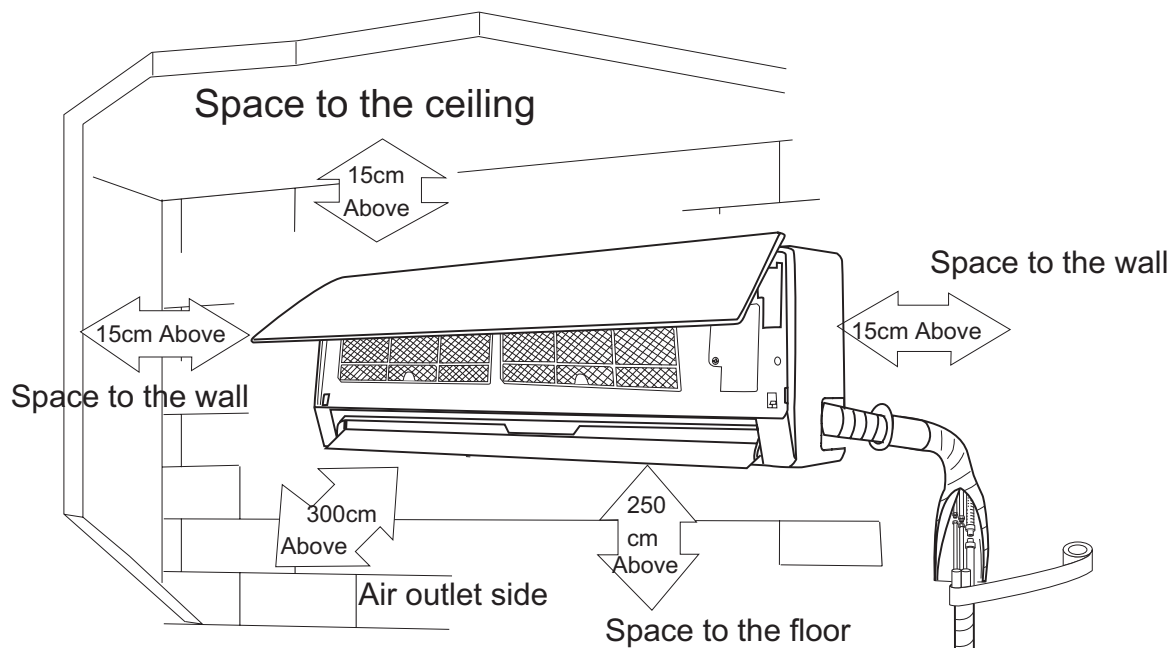

- The dimensions of the space necessary for correct installation of the appliance including the minimum permissible distances to adjacent structures

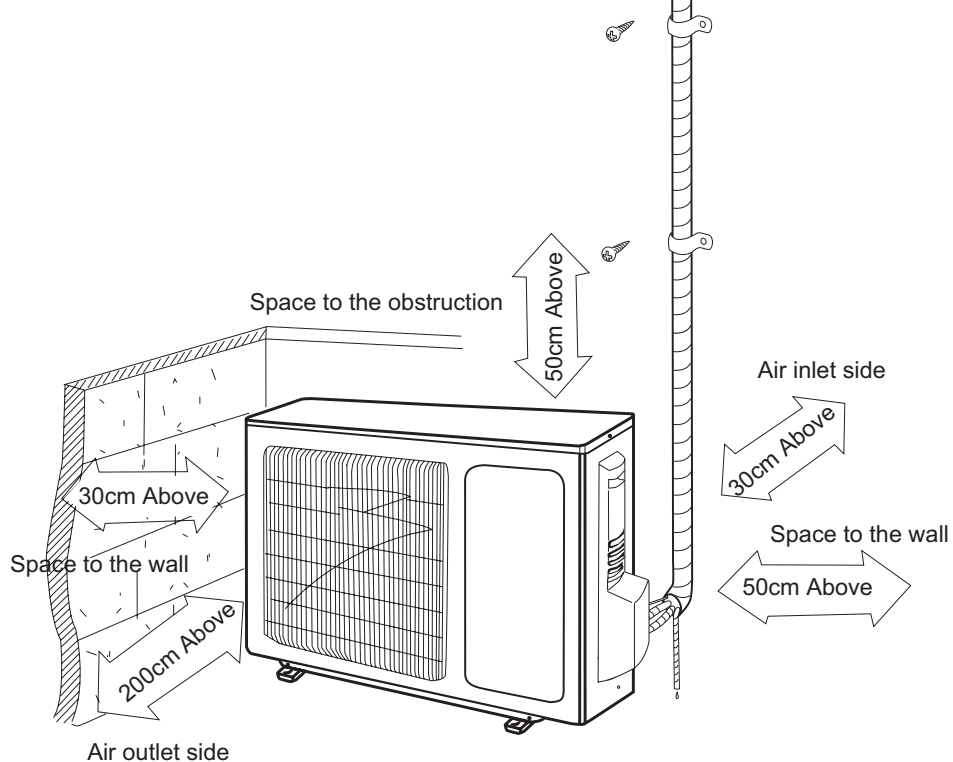

## 7.3 Install Indoor Unit

### 7.3.1 Installation of Mounting Plate

1. Mounting plate should be installed horizontally. As the water tray's outlet for the indoor unit is two-way type, during installation, the indoor unit should slightly slant to water tray's outlet for smooth drainage of condensate.
2. Fix the mounting plate on the wall with screws. (Where is pre-covered with plastic granula)
3. Be sure that the mounting plate has been fixed firmly enough to withstand about 60 kg. Meanwhile, the weight should be evenly shared by each screw.

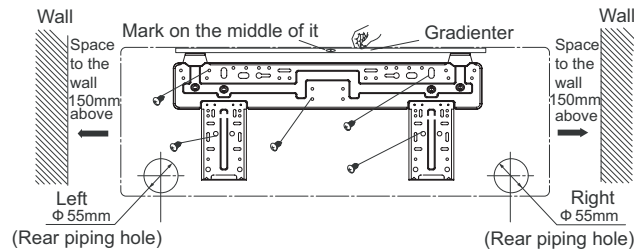

### 7.3.2 Drill Piping Hole

1. Slant the piping hole ( $\Phi 55$ ) on the wall slightly downward to the outdoor side.
2. Insert the piping-hole sleeve into the hole to prevent the connection piping and wiring from being damaged when passing through the hole.

### 7.3.3 Installation of Drain Hose

1. Connect the drain hose to the outlet pipe of the indoor unit. Bind the joint with rubber belt.
  2. Put the drain hose into insulating tube.
  3. Wrap the insulating tube with wide rubber belt to prevent the shift of insulating tube.
- Slant the drain hose downward slightly for smooth drainage of condensate.

**Note:** The insulating tube should be connected reliably with the sleeve outside the outlet pipe. The drain hose should be slanted downward slightly, without distortion, bulge or fluctuation. Do not put the outlet in the water.

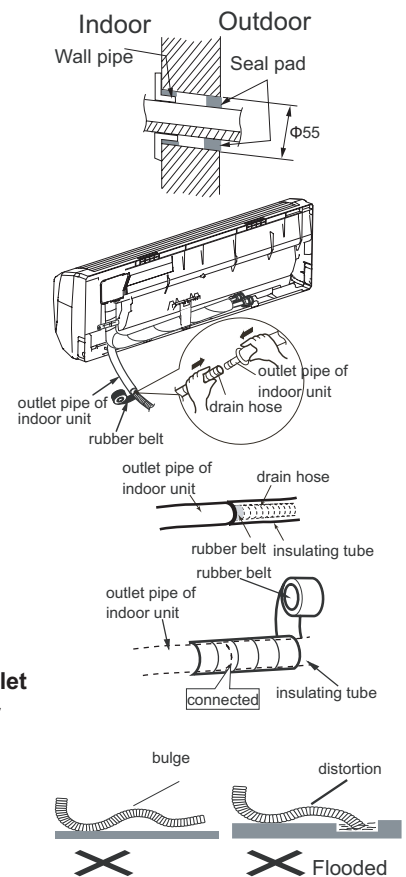

### 7.3.4 Connecting Indoor and Outdoor Electric Wires

1. Open the front panel.
2. Remove the wiring cover. Connect and fix power connection cord and signal control wire to the terminal board. As shown in Fig.2.
3. Make the power connection cord and signal control wire through the hole at the back of indoor unit.
4. Reinstall the cord and wiring cover.
5. Reinstall the front panel.

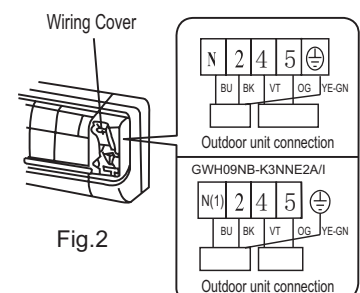

**NOTE:**

All wires between indoor and outdoor units must be connected by the qualified electric contractor.

- Electric wires must be connected correctly. Improper connection may cause malfunction.
- Tighten the terminal screws securely.
- After tightening the screws, pull the wire slightly to confirm whether it is firm or not.
- Make sure that the electric connections are earthed properly to prevent electric shock.
- Make sure that all wiring connections are secure and the cover plates are reinstalled properly. Poor installation may cause fire orelectric shock.

**7.3.5 Installation of Indoor Unit**

- The piping can be output from right, right rear, left or left rear.
- 1.When routing the piping and wiring from the left or right side of indoor unit, cut off the tailings from the chassis when necessary(As shown in Fig.3)
    - (1)Cut off tailing 1 when routing the wiring only;
    - (2)Cut off tailing 1 and tailing 2 when routing both the wiring and piping.
  - 2.Take out the piping from body case; wrap the piping,power cords, drain hose with the tape and then make them pass through the piping hole. (As shown in Fig.4)
  - 3.Hang the mounting slots of the indoor unit on the upper hooks of the mounting plate and check if it is firm enough. (As shown in Fig.5)
  - 4.The installation site should be 250cm or more above the floor.

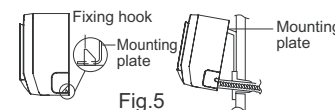
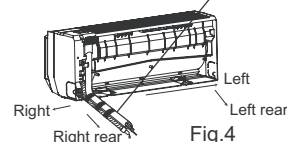
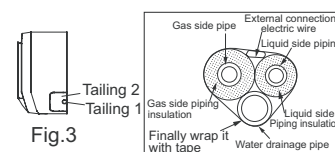

**7.3.6 Installation of Connection Pipe**

- 1.Align the center of the pipe flare with the related valve.
- 2.Screw in the flare nut by hand and then tighten the nut with spanner and torque wrench by referring to the following:

Hex nut diameter	Tightening torque (N·m)
Φ6	15~20
Φ 9.52	31~35
Φ 12	50~55
Φ 16	60~65
Φ 19	70~75

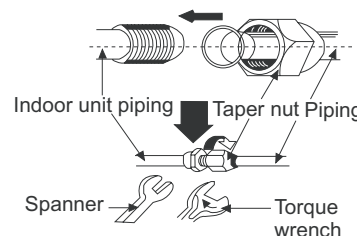

**NOTE: Connect the connection pipe to indoor unit at first and then to outdoor unit. Handle piping bending with care. Do not damage the connection pipe. Ensure that the joint nutis tightened firmly, otherwise, it may cause leakage.**

**7.4 Install Outdoor Unit**

**7.4.1 Electric Wiring**

- 1.Remove the handle on the right side plate of outdoor unit.
- 2.Take off wire cord anchorage. Connect and fix power connection cord and signal control wire to the terminal board.Wiring should fit that of indoor unit.
- 3.Fix the power connection cord and signal control wire with wire clamps and then connect the corre-sponding connector.
- 4.Confirm if the wire has been fixed properly.
- 5.Reinstall the handle.

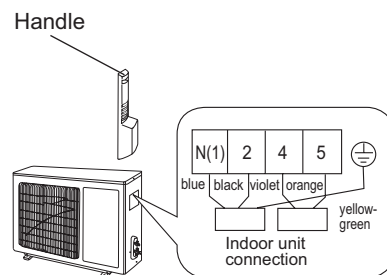

**NOTE:**

- Incorrect wiring may cause malfunction of spare part.
- After the wire has been fixed, ensure there is frees pace between the connection and fixing places on the lead wire. Schematic diagram being reference only, please refer to real product for authentic information.

### 7.4.2 Air Purging and Leakage Test

1. Connect charging hose of manifold valve to charge end of low pressure valve (both high/low pressure valves must be tightly shut).
2. Connect joint of charging hose to vacuum pump.
3. Fully open the handle of Lo manifold valve.
4. Open the vacuum pump for vacuumization. At the beginning, slightly loosen joint nut of low pressure valve to check if there is air coming inside (If noise of vacuum pump has been changed, the reading of multimeter is 0). Then tighten the nut.
5. Keep vacuuming for more than 15mins and make sure the reading of multimeter is  $-1.0 \times 10^5$  pa (-76cmHg).
6. Fully open high/low pressure valves.
7. Remove charging hose from charging end of low pressure valve.
8. Tighten lid of low pressure valve. (As shown in Fig.6)

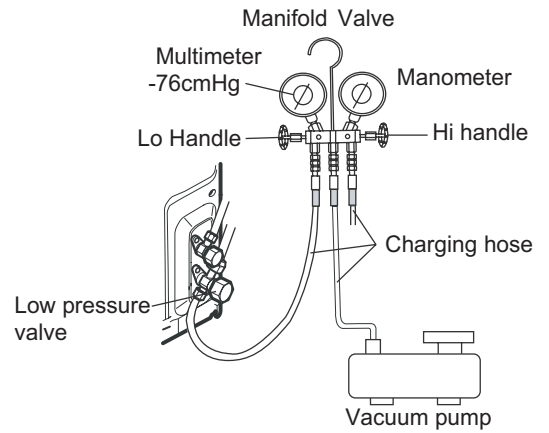
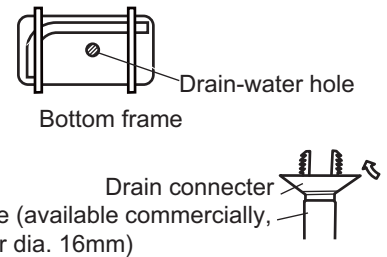

Fig.6

### 7.4.3 Outdoor Condensate Drainage (only for heat pump unit)

During heating operation, the condensate and defrosting water should be drained out reliably through the drain hose. Install the outdoor drain connector in a  $\Phi 25$  hole on the base plate and attach the drain hose to the connector so that the waste water formed in the outdoor unit can be drained out. The hole diameter 25 must be plugged. Whether to plug other holes will be determined by the dealers according to actual conditions.



## 7.5 Check after Installation and Test Operation

### 7.5.1 Check after Installation

Items to be checked	Possible malfunction
Has it been fixed firmly?	The unit may drop, shake or emit noise.
Have you done the refrigerant leakage test?	It may cause insufficient cooling(heating) capacity
Is heat insulation sufficient?	It may cause condensation and dripping.
Is water drainage satisfactory?	It may cause condensation and dripping.
Is the voltage in accordance with the rated voltage marked on the nameplate?	It may cause electric malfunction or damage the product.
Is the electric wiring and piping connection installed correctly and securely?	It may cause electric malfunction or damage the part.
Has the unit been connected to a secure earth connection?	It may cause electrical leakage.
Is the power cord specified?	It may cause electric malfunction or damage the part.
Are the inlet and outlet openings blocked?	It may cause insufficient cooling(heating) capacity.
Is the length of connection pipes and refrigerant capacity been recorded?	The refrigerant capacity is not accurate.

## 7.5.2 Operation Test

### 1. Before Operation Test

- (1) Do not switch on power before installation is finished completely.
- (2) Electric wiring must be connected correctly and securely.
- (3) Cut-off valves of the connection pipes should be opened.
- (4) All the impurities such as scraps and thrums must be cleared from the unit.

### 2. Operation Test Method

- (1) Switch on power, press "ON/OFF" button on the wireless remote control to start the operation.
- (2) Press MODE button, to select the COOL, HEAT, FAN to check whether the operation is normal or not.

## 7.6 Installation and Maintenance of Healthy Filter

### 7.6.1 Installation of Healthy Filter

1. Lift up the front panel from its two ends, as shown by the arrow direction, and then remove the air filter. (As shown in Fig.a)
2. Attach the healthy filter onto the air filter, (As shown in Fig.b).
3. Install the air filter properly along the arrow direction in Fig.c, and then close the panel.

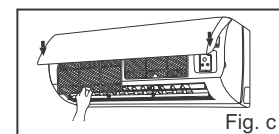
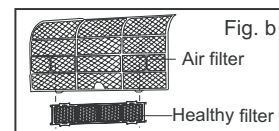
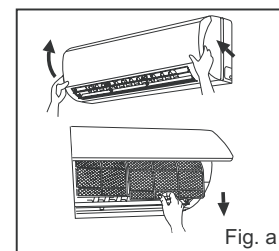

### 7.6.2 Cleaning and Maintenance

Remove the healthy filter and reinstall it after cleaning according to the installation instruction. Do not use brush or hard objects to clean the filter. After cleaning, be sure to dry it in the shade.

### 7.6.3 Service Life

The general service life for the healthy filter is about one year under normal condition. As for silver ion filter, it is ineffective when its surface becomes black (green).

This supplementary instruction is provided for reference to the unit with healthy filter. If the graphics provided herein are different from the actual product, please refer to the actual product. The quantity of healthy filters is based on the actual delivery.

## 8. Exploded Views and Parts List

### 8.1 Indoor Unit

Models:GWH07NA-K3NNA4A/I(Cold Plasma) GWH09NA-K3NNA4A/I(Cold Plasma)  
GWH12NB-K3NNA4A/I(Cold Plasma)

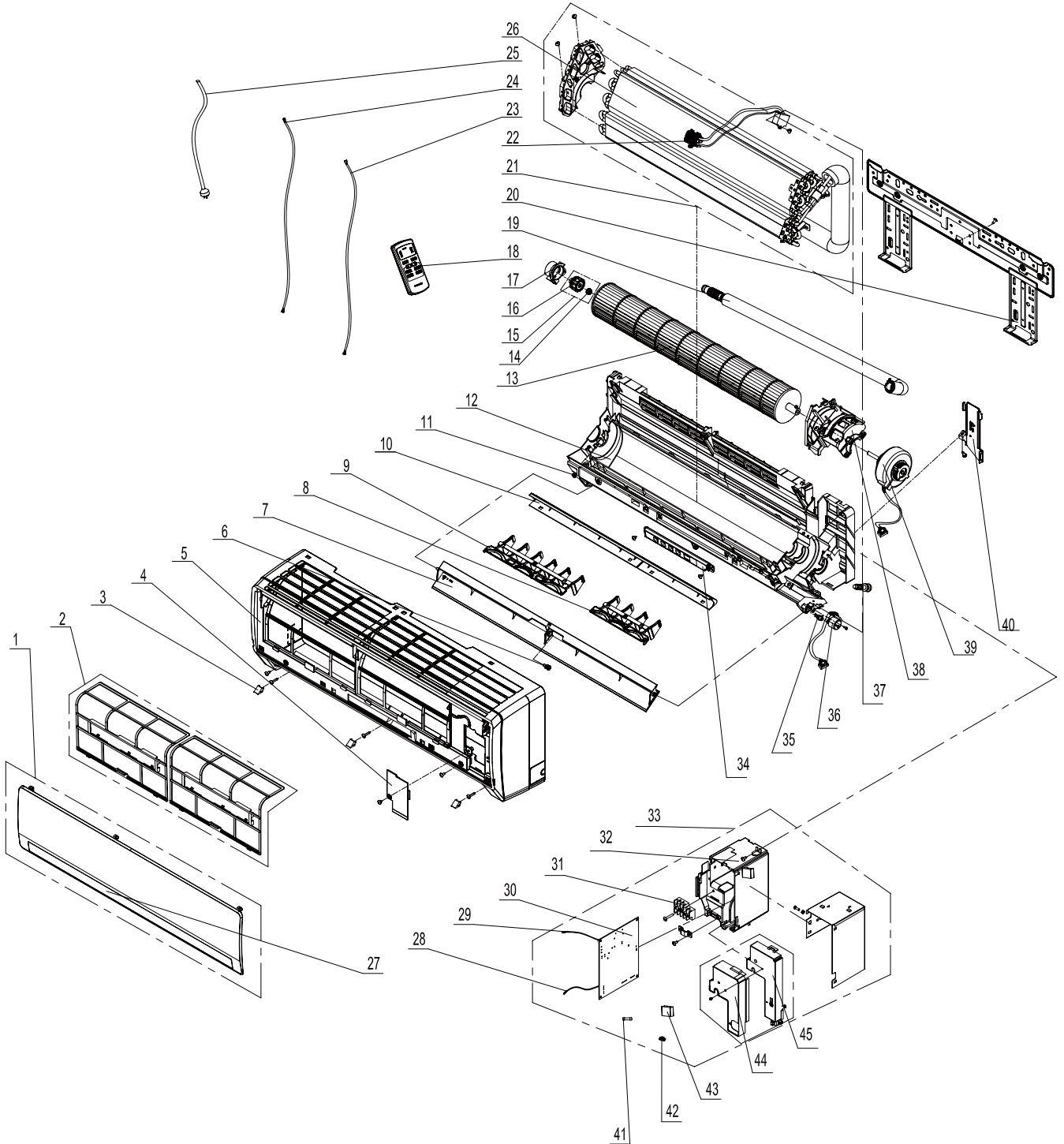



NO.	Description	Part Code		Qty
		GWH07NA-K3NNA4A/I	GWH09NA-K3NNA4A/I	
		(Cold Plasma)	(Cold Plasma)	
	Product Code	CA161N0161	CA161N0173	
1	Front Panel Assy	20012519	20012519	1
2	Filter Sub-Assy	11122095	11122095	2
3	Screw Cover	24252016	24252016	3
4	Electric Box Cover2	20122075	20122075	1
5	Front Case	2001239601	2001239601	1
6	Axile Bush	10542008	10542008	1
7	Guide Louver	10512162	10512162	1
8	Air Louver 1	10512113	10512113	1
9	Air Louver 2	10512114	10512114	1
10	Helicoid Tongue	26112202	26112202	1
11	Axile Bush	10542704	10542704	1
12	Rear Case assy	2220213501	2220213501	1
13	Cross Flow Fan	10352034	10352034	1
14	Fan Bearing	76512210	76512210	1
15	O-Gasket sub-assy of Bearing	76512051	76512051	1
16	O-Gasket of Cross Fan Bearing	76512203	76512203	1
17	Ring of Bearing	26152022	26152022	1
18	Remote Controller	30510065	30510065	1
19	Drainage Hose	0523001408	0523001408	1
20	Wall Mounting Frame	01252231	01252231	1
21	Evaporator Assy	01002577	0100257701	1
22	Cold Plasma Generator Sub-assy	11140009	11140009	1
23	Connecting Cable	40020540	40020540	1
24	Connecting Cable	40020536	40020536	1
25	Power Cord	400220113	400220113	1
26	Evaporator Sub-Assy	01032915	01032915	1
27	Receiver Window	22432178	22432178	1
28	Tube Sensor	390000591	390000591	1
29	Ambient Temperature Sensor	390000453	390000453	1
30	Main Board	30135357	30135357	1
31	Terminal Board	42010262	42010262	1
32	Electric Box	20112091	20112091	1
33	Electric Box Assy	2020245002	20202455	1
34	Display Board	30565012	30565012	1
35	Crank	10582070	10582070	1
36	Step Motor	1521212901	1521212901	1
37	Rubber Plug (Water Tray)	76712012	76712012	1
38	Motor Press Plate	26112201	26112201	1
39	Fan Motor	15012115	15012115	1
40	Pipe Clamp	26112199	26112199	1
41	Fuse	46010055	46010055	1
42	Jumper	4202300115	4202300114	1
43	Capacitor CBB61	33010002	33010002	1
44	ShieldBox (Electric Box)	01592080	01592080	1
45	Electric Box Cover	20122114	20122114	1

The data above are subject to change without notice.

NO.	Description	Part Code	Qty
		GWH12NB-K3NNA4A/I(Cold Plasma)	
	Product Code	CA161N0291	
1	Front Panel Assy	2001217601	1
2	Filter Sub-Assy	11122081	2
3	Screw Cover	24252016	3
4	Electric Box Cover2	20122075	1
5	Front Case	20012120	1
6	Axile Bush	10542704	1
7	Guide Louver	10512111	1
8	Air Louver 1	10512113	1
9	Air Louver 2	10512114	1
10	Helicoid Tongue	26112162	1
11	Axile Bush	10542704	1
12	Rear Case assy	2220210101	1
13	Cross Flow Fan	10352018	1
14	Fan Bearing	76512210	1
15	O-Gasket sub-assy of Bearing	76512051	1
16	O-Gasket of Cross Fan Bearing	76512203	1
17	Ring of Bearing	26152022	1
18	Remote Controller	30510065	1
19	Drainage Hose	0523001406	1
20	Wall Mounting Frame	01252015	1
21	Evaporator Assy	0100255213	1
22	Cold Plasma Generator Sub-assy	11140009	1
23	Connecting Cable	40020540	1
24	Connecting Cable	40020536	1
25	Power Cord	4002046413	1
26	Evaporator Sub-Assy	01032564	1
27	Receiver Window	22430131	1
28	Tube Sensor	390000591	1
29	Ambient Temperature Sensor	390000453	1
30	Main Board	30135416	1
31	Terminal Board	42010262	1
32	Electric Box	20112082	1
33	Electric Box Assy	20202454	1
34	Display Board	30565012	1
35	Crank	10582070	1
36	Step Motor	1521212901	1
37	Rubber Plug (Water Tray)	76712012	1
38	Motor Press Plate	26112160	1
39	Fan Motor	15012115	1
40	Pipe Clamp	26112164	1
41	Fuse	46010014	1
42	Jumper	4202300128	1
43	Capacitor CBB61	33010002	1
44	ShieldBox (Electric Box)	0141203601	1
45	Electric Box Cover	20122103	1

The data above are subject to change without notice.

Models:GWH07NA-K3NND2A/I GWH07NA-K3NNA8A/I

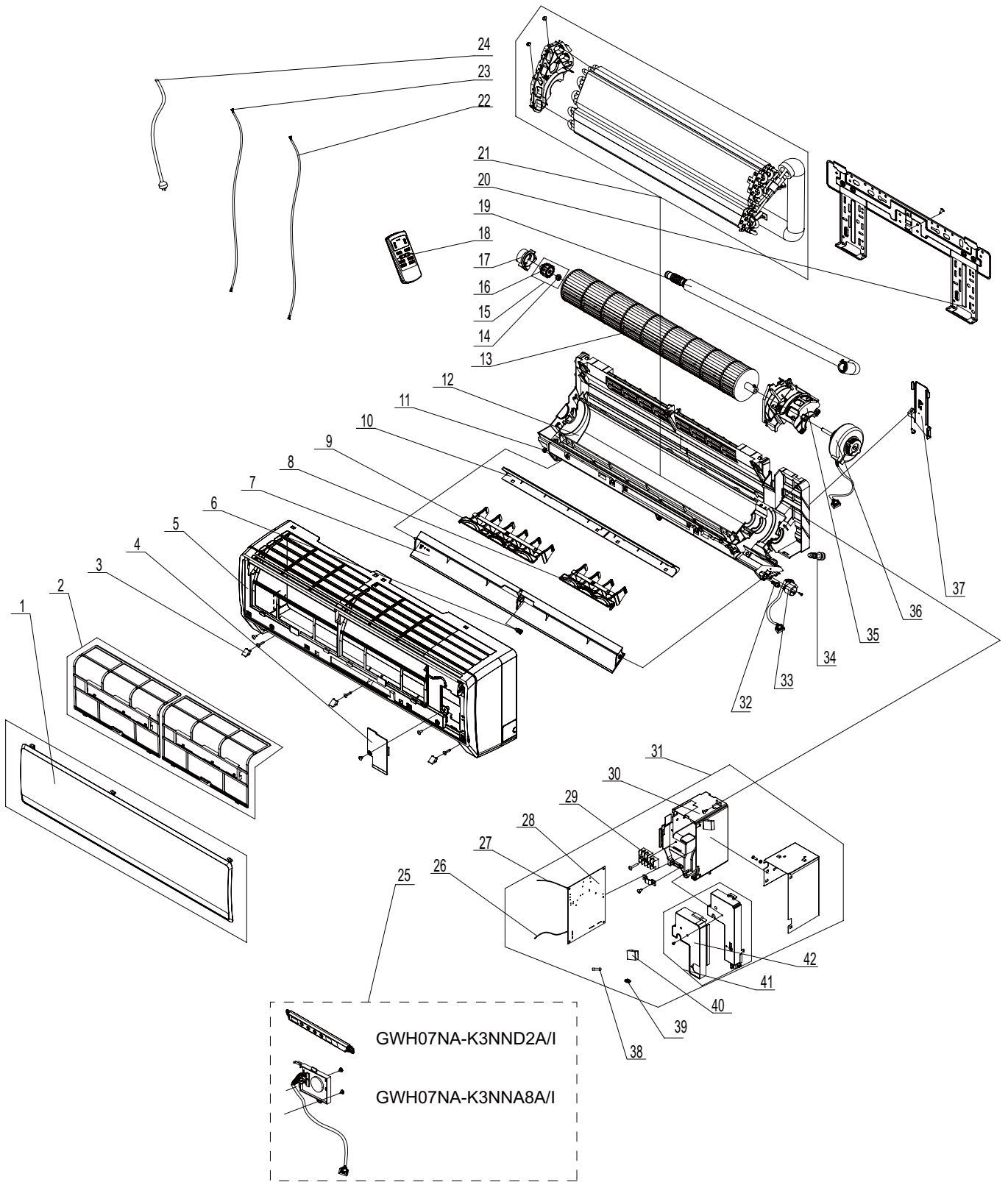

NO.	Description	Part Code		Qty
		GWH07NA-K3NNA8A/I	GWH07NA-K3NND2A/I	
		Product Code	CA173N0300	
1	Front Panel Assy	20012538	20012927	1
2	Filter Sub-Assy	11122095	24252016	2
3	Screw Cover	24252016	11122095	3
4	Electric Box Cover2	20122075	20122075	1
5	Front Case	20022286	20022286	1
6	Axile Bush	10542036	10542036	1
7	Guide Louver	10512162	10512162	1
8	Air Louver 1	10512113	10512113	1
9	Air Louver 2	10512114	10512114	1
10	Helicoid Tongue	26112202	26112202	1
11	Axile Bush	10542704	10542704	1
12	Rear Case assy	22202135	22202135	1
13	Cross Flow Fan	10352034	10352034	1
14	Fan Bearing	76512210	76512210	1
15	O-Gasket sub-assy of Bearing	76512051	76512051	1
16	O-Gasket of Cross Fan Bearing	76512203	76512203	1
17	Ring of Bearing	26152022	26152022	1
18	Remote Controller	30510065	30510065	1
19	Drainage Hose	0523001408	0523001408	1
20	Wall Mounting Frame	01252231	01252231	1
21	Evaporator Assy	01002577	01002577	1
22	Connecting Cable	40020540	40020540	0
23	Connecting Cable	40020536	40020536	0
24	Power Cord	400220113	400220113	1
25	Display Board	3056504301	3056506401	1
26	Ambient Temperature Sensor	390000453	390000453	1
27	Temperature Sensor	390000597	390000597	1
28	Main Board	30135353	30135353	1
29	Terminal Board	42010262	42010262	1
30	Electric Box	20112091	20112091	1
31	Electric Box Assy	20202327	20302979	1
32	Crank	10582070	10582070	1
33	Step Motor	1521212901	1521212901	1
34	Rubber Plug (Water Tray)	76712012	76712012	1
35	Motor Press Plate	26112201	26112201	1
36	Fan Motor	15012115	15012115	1
37	Pipe Clamp	26112199	26112199	1
38	Fuse	46010055	46010055	1
39	Jumper	4202300115	4202300115	1
40	Capacitor CBB61	33010002	33010002	1
41	ShieldBox (Electric Box)	01592080	01592080	1
42	Electric Box Cover	20122114	20122114	1

The data above are subject to change without notice.

Models:GWH09NA-K3NNA2A/I(Membrana Decorative Strip)  
 GWH09NA-K3NNA2A/I GWH09NA-K3NNA2C/I

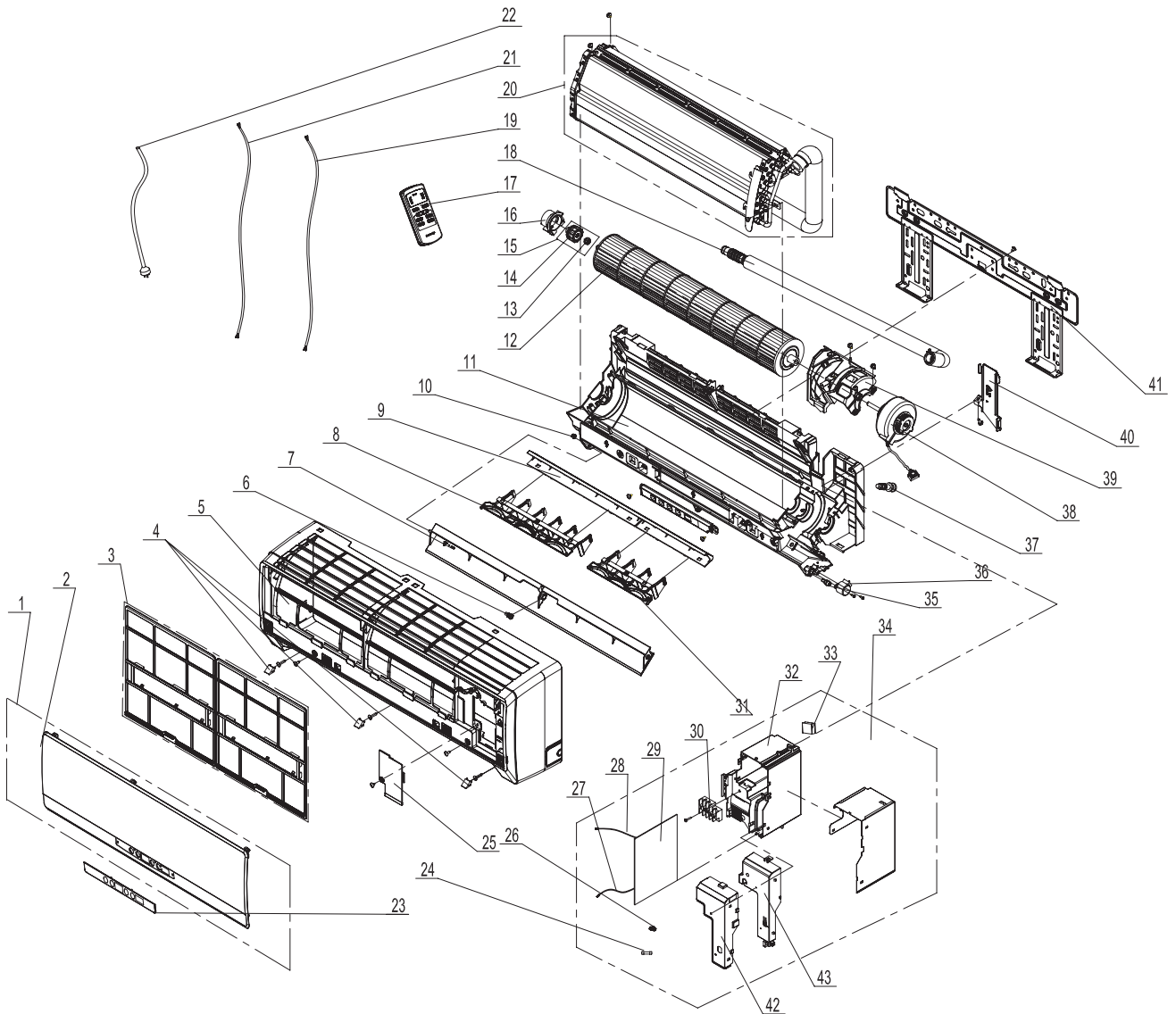

NO.	Description	Part Code		Qty
		GWH09NA-K3NNA2A/I (Membrana Decorative Strip)		
		Product Code	CA181N0193	
1	Front Panel Assy		20012918	1
2	Filter Sub-Assy		11122095	2
3	Screw Cover		24252016	3
4	Front Case		2001239601	1
5	Axile Bush		10542008	1
6	Guide Louver		10512162	1
7	Air Louver 2		10512114	1
8	Helicoid tongue		26112202	1
9	Display Board		30565054	1
10	Axile Bush		10542704	1
11	Rear Case assy		2220213501	1
12	Cross Flow Fan		10352034	1
13	Fan Bearing		76512210	1
14	O-Gasket of Cross Fan Bearing		76512203	1
15	O-Gasket sub-assy of Bearing		76512051	1
16	Ring of Bearing		26152022	1
17	Remote Controller		30510065	1
18	Drainage hose		0523001408	1
19	Connecting Cable		40020540	1
20	Evaporator Assy		0100257701	1
21	Connecting Cable		40020536	1
22	Power Cord		400220113	1
23	Receiver Window		20192462	1
24	Fuse		46010055	1
25	Electric Box Cover2		20122075	1
26	Jumper		4202300114	1
27	Tube Sensor		390000591	1
28	Ambient Temperature Sensor		390000453	1
29	Main Board		30135353	1
30	Terminal Board		42010262	1
31	Air Louver 1		10512113	1
32	Electric Box		20112091	1
33	Capacitor CBB61		33010002	1
34	Electric Box Assy		2020223304	1
35	Crank		10582070	1
36	Step Motor		1521212901	1
37	Rubber Plug (Water Tray)		76712012	1
38	Fan Motor		15012115	1
39	Motor Press Plate		26112201	1
40	Pipe Clamp		26112199	1
41	Wall Mounting Frame		01252231	1
42	Shield box (electric box)		01592080	1
43	Electric Box Cover		20122114	1

The data above are subject to change without notice.

NO.	Description	Part Code		Qty
		GWH09NA-K3NNA2A/I	GWH09NA-K3NNA2C/I	
		Product Code	CA181N0190	
1	Front Panel Assy	20012537	20012537	1
2	Filter Sub-Assy	11122095	11122095	2
3	Screw Cover	24252016	24252016	3
4	Front Case	2001239601	2002228601	1
5	Axile Bush	10542008	10542036	1
6	Guide Louver	10512162	10512162	1
7	Air Louver 2	10512114	10512114	1
8	Helicoid tongue	26112202	26112202	1
9	Display Board	30565056	30565056	1
10	Axile Bush	10542704	10542704	1
11	Rear Case assy	2220213501	2220213501	1
12	Cross Flow Fan	10352034	10352034	1
13	Fan Bearing	76512210	76512210	1
14	O-Gasket of Cross Fan Bearing	76512203	76512203	1
15	O-Gasket sub-assy of Bearing	76512051	76512051	1
16	Ring of Bearing	26152022	26152022	1
17	Remote Controller	30510065	30510065	1
18	Drainage hose	0523001408	0523001408	1
19	Connecting Cable	40020540	40020540	1
20	Evaporator Assy	0100257701	01002577	1
21	Connecting Cable	40020536	40020536	1
22	Power Cord	400220113	400220113	1
23	Receiver Window	20192364	20192364	1
24	Fuse	46010055	46010055	1
25	Electric Box Cover2	20122075	20122075	1
26	Jumper	4202300114	4202300114	1
27	Tube Sensor	390000591	390000597	1
28	Ambient Temperature Sensor	30135353	390000453	1
29	Main Board	390000453	30135353	1
30	Terminal Board	42010262	42010262	1
31	Air Louver 1	10512113	10512113	1
32	Electric Box	20112091	20112091	1
33	Capacitor CBB61	33010002	33010002	1
34	Electric Box Assy	2020232601	2020232601	1
35	Crank	10582070	10582070	1
36	Step Motor	1521212901	1521212901	1
37	Rubber Plug (Water Tray)	76712012	76712012	1
38	Fan Motor	15012115	15012115	1
39	Motor Press Plate	26112201	26112201	1
40	Pipe Clamp	26112199	26112199	1
41	Wall Mounting Frame	01252231	01252231	1
42	Shield box (electric box)	01592080	01592080	1
43	Electric Box Cover	20122114	20122114	1

The data above are subject to change without notice.

Model:GWH09NB-K3NNE2A/I

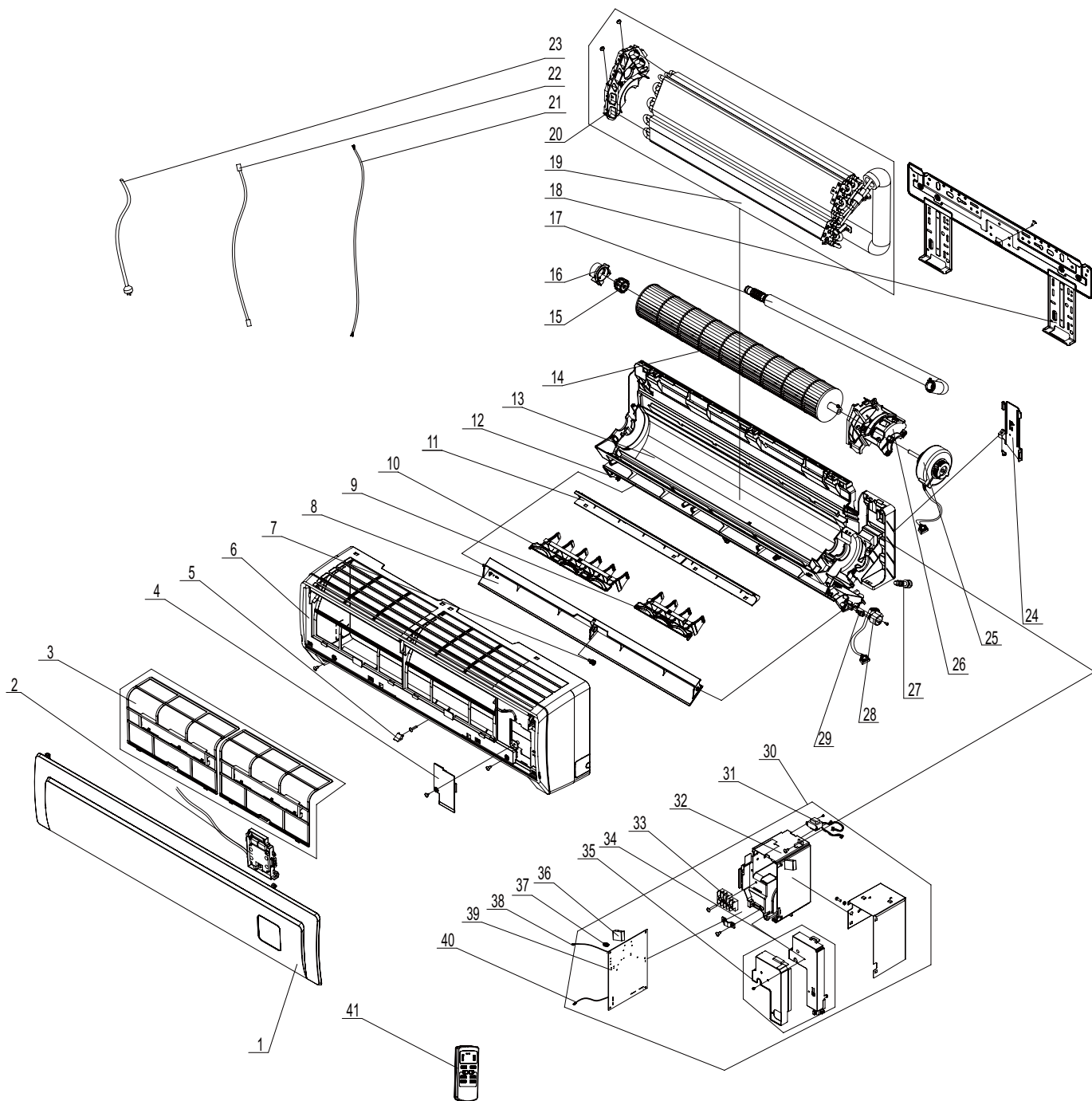



NO.	Description	Part Code		Qty
		GWH09NB-K3NNE2A/I		
		CA401N02900		
1	Front Panel Assy	20012816	1	
2	Display Board	30565126	1	
3	Filter Sub-Assy	11122081	2	
4	Electric Box Cover2	20122075	1	
5	Screw Cover	24252016	1	
6	Front Case	20012179	1	
7	Axile Bush	10542704	1	
8	Guide Louver	10512111	1	
9	Air Louver 1	10512113	1	
10	Air Louver 2	10512114	1	
11	Helicoid Tongue	26112162	1	
12	Axile Bush	10542036	1	
13	Rear Case assy	2220210101	1	
14	Cross Flow Fan	10352018	1	
15	O-Gasket sub-assy of Bearing	76512051	1	
16	Ring of Bearing	26152022	1	
17	Drainage Hose	0523001406	1	
18	Wall Mounting Frame	01252015	1	
19	Evaporator Assy	0100238903	1	
20	Evaporator Support	24212161	1	
21	Connecting Cable	40020540	0	
22	Connecting Cable	40020536	0	
23	Power Cord	4002046417	1	
24	Pipe Clamp	26112164	1	
25	Fan Motor	15012115	1	
26	Motor Press Plate	26112160	1	
27	Rubber Plug (Water Tray)	76712012	1	
28	Step Motor	1521212901	1	
29	Crank	10582070	1	
30	Electric Box Assy	20302929	1	
31	High Frequency Transformer	43110043	1	
32	Electric Box	2011216701	1	
33	Terminal Board	42010268	1	
34	"Shield Cover of Electric Box Sub-assy"	0159207301	1	
35	Electric Box Cover1	20122103	1	
36	Capacitor CBB61	33010002	1	
37	Jumper	4202300128	1	
38	Ambient Temperature Sensor	390000453	1	
39	Main Board	30135448	1	
40	Temperature Sensor	390000591	1	
41	Remote Controller	30510065	1	

The data above are subject to change without notice.

Models:GWH12NB-K3NNA2A/I(Membrana Decorative Strip)  
GWH12NB-K3NNA2A/I

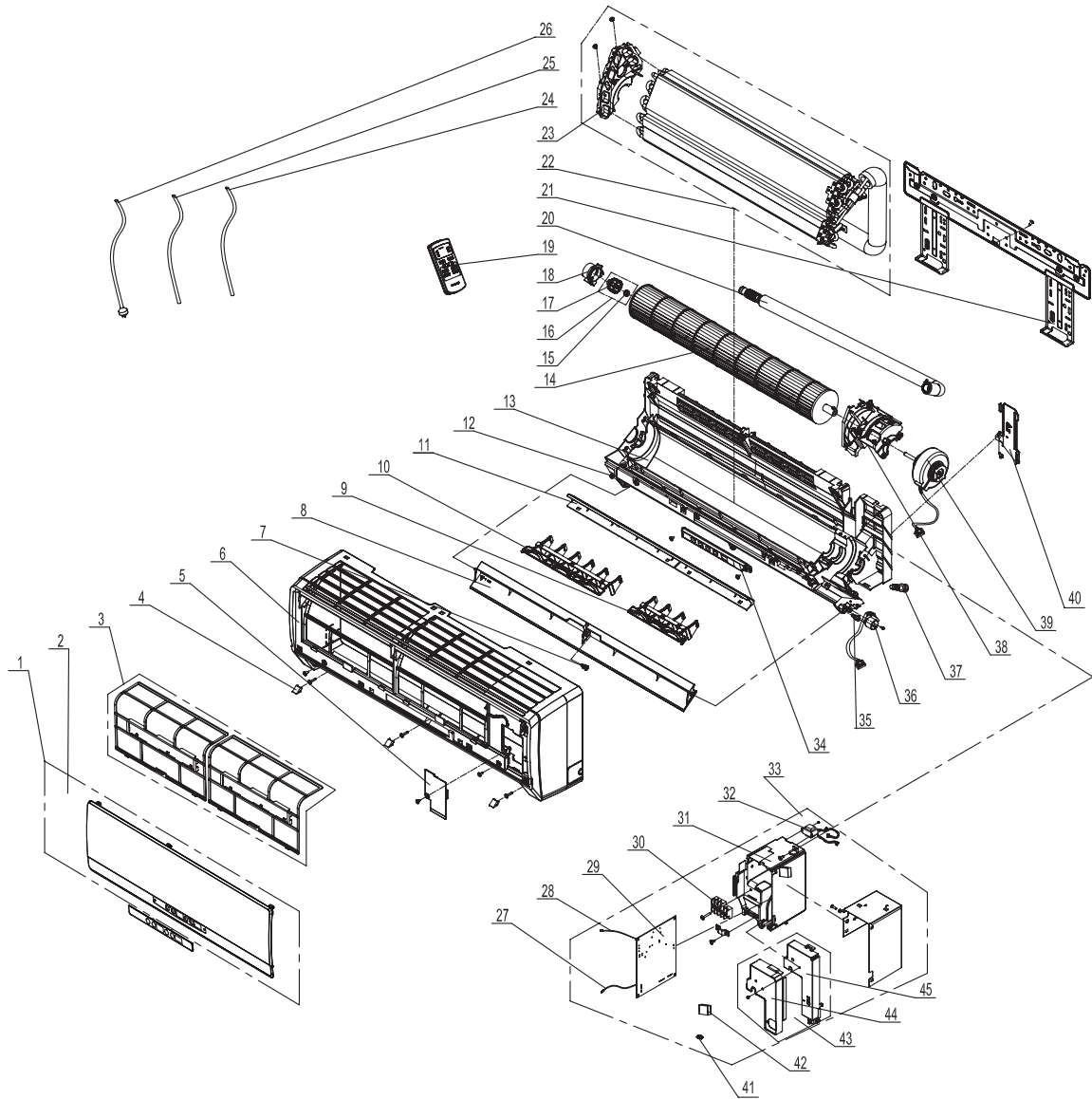

NO.	Description	Part Code	Qty
		GWH12NB-K3NNA2A/I(Membrana Decorative Strip)	
	Product Code	CA181N0231	
1	Front Panel Assy	20012919	1
2	Front panel B1	20012896S	1
3	Filter Sub-Assy	11122081	2
4	Screw Cover	24252016	3
5	Electric Box Cover2	20122075	1
6	Front Case	20012120	1
7	Axile Bush	10542008	1
8	Guide Louver	10512111	1
9	Air Louver 1	10512113	1
10	Air Louver 2	10512114	1
11	Helicoid tongue	26112162	1
12	Axile Bush	10542704	1
13	Rear Case assy	2220210101	1
14	Cross Flow Fan	10352018	1
15	Fan Bearing	76512210	1
16	O-Gasket sub-assy of Bearing	76512051	1
17	O-Gasket of Cross Fan Bearing	76512203	1
18	Ring of Bearing	26152022	1
19	Remote Controller	30510065	1
20	Drainage hose	0523001406	1
21	Wall Mounting Frame	01252015	1
22	Evaporator Assy	0100255213	1
23	Evaporator Support	24212090	1
24	Connecting Cable	40020540	1
25	Connecting Cable	40020536	1
26	Power Cord	4002046413	1
27	Tube Sensor	390000591	1
28	Ambient Temperature Sensor	390000453	1
29	Main Board	30135283	1
30	Terminal Board	42010262	1
31	Electric Box	20112082	1
32	Transformer	43110236	1
33	Electric Box Assy	20202169	1
34	Display Board	30565054	1
35	Crank	10582070	1
36	Step Motor	1521212901	1
37	Rubber Plug (Water Tray)	76712012	1
38	Motor Press Plate	26112160	1
39	Fan Motor	15012115	1
40	Pipe Clamp	26112164	1
41	Jumper	4202300128	1
42	Capacitor CBB61	33010002	1
43	Shield cover of Electric Box sub-assy	0159207301	1
44	Shield cover of Electric Box	0141203601	1
45	Electric Box Cover1	20122103	1

The data above are subject to change without notice.

NO.	Description	Part Code	Qty
		GWH12NB-K3NNA2A/I	
	Product Code	CA181N0230	
1	Front Panel Assy	2001216401	1
2	Front panel B1	20012896S	1
3	Filter Sub-Assy	11122081	2
4	Screw Cover	24252016	3
5	Electric Box Cover2	20122075	1
6	Front Case	20012120	1
7	Axile Bush	10542008	1
8	Guide Louver	10512111	1
9	Air Louver 1	10512113	1
10	Air Louver 2	10512114	1
11	Helicoid tongue	26112162	1
12	Axile Bush	10542704	1
13	Rear Case assy	2220210101	1
14	Cross Flow Fan	10352018	1
15	Fan Bearing	76512210	1
16	O-Gasket sub-assy of Bearing	76512051	1
17	O-Gasket of Cross Fan Bearing	76512203	1
18	Ring of Bearing	26152022	1
19	Remote Controller	30510065	1
20	Drainage hose	0523001406	1
21	Wall Mounting Frame	01252015	1
22	Evaporator Assy	0100257701	1
23	Evaporator Support	24212090	1
24	Connecting Cable	40020540	1
25	Connecting Cable	40020536	1
26	Power Cord	400220113	1
27	Tube Sensor	390000591	1
28	Ambient Temperature Sensor	390000453	1
29	Main Board	30135283	1
30	Terminal Board	42010262	1
31	Electric Box	20112082	1
32	Transformer	43110236	1
33	Electric Box Assy	20202378	1
34	Display Board	30565056	1
35	Crank	10582070	1
36	Step Motor	1521212901	1
37	Rubber Plug (Water Tray)	76712012	1
38	Motor Press Plate	26112160	1
39	Fan Motor	15012115	1
40	Pipe Clamp	26112164	1
41	Jumper	4202300128	1
42	Capacitor CBB61	33010002	1
43	Shield cover of Electric Box sub-assy	0159207301	1
44	Shield cover of Electric Box	0141203601	1
45	Electric Box Cover1	20122103	1

The data above are subject to change without notice.

Model:GWH12NB-K3NNC7C/I

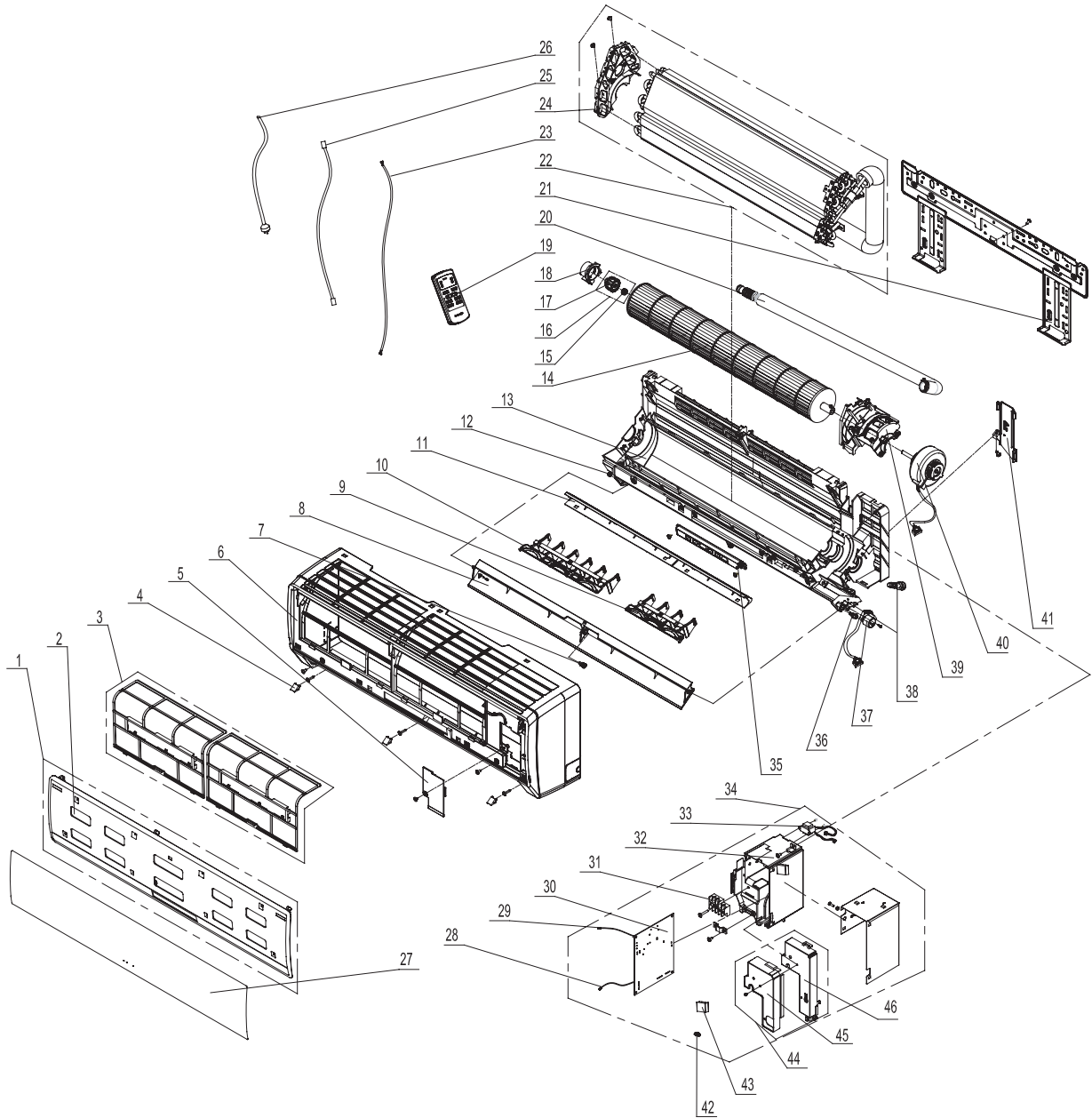

Exploded Views and Parts List

NO.	Description	Part Code	Qty
		GWH12NB-K3NNC7C/I	
Product Code		CA195N04600	
1	Front Panel Assy	2001239807	1
2	Front Panel	20012393	1
3	Filter Sub-Assy	11122081	2
4	Screw Cover	24252016	3
5	Electric Box Cover2	20122075	1
6	Front Case	20012120	1
7	Axile Bush	10542008	1
8	Guide Louver	10512111	1
9	Air Louver 1	10512113	1
10	Air Louver 2	10512114	1
11	Helicoid tongue	26112162	1
12	Axile Bush	10542704	1
13	Rear Case assy	2220210101	1
14	Cross Flow Fan	10352018	1
15	Fan Bearing	76512210	1
16	O-Gasket of Cross Fan Bearing	76512203	1
17	O-Gasket sub-assy of Bearing	76512051	1
18	Ring of Bearing	26152022	1
19	Remote Controller	30510065	1
20	Drainage hose	0523001406	1
21	Wall Mounting Frame	01252015	1
22	Evaporator Assy	0100255202	1
23	Connecting Cable	40020540	1
24	Evaporator Support	24212090	1
25	Connecting Cable	40020536	1
26	Power Cord	400220113	1
27	Decorative Board	2019230505S	1
28	Tube Sensor	390000591	1
29	Ambient Temperature Sensor	390000453	1
30	Main Board	30135283	1
31	Terminal Board	42010262	1
32	Electric Box	20112082	1
33	Transformer	43110236	1
34	Electric Box Assy	2020216902	1
35	Display Board	30565050	1
36	Crank	10582070	1
37	Step Motor	1521212901	1
38	Rubber Plug (Water Tray)	76712012	1
39	Motor Press Plate	26112160	1
40	Fan Motor	15012115	1
41	Pipe Clamp	26112164	1
42	Jumper	4202300128	1
43	Capacitor CBB61	33010002	1
44	Shield cover of Electric Box sub-assy	0159207301	1
45	Shield cover of Electric Box	0141203601	1
46	Electric Box Cover1	20122103	1

The data above are subject to change without notice.

Models:GWH07NA-K3NNB3A/I(Cold Plasma) GWH09NA-K3NNB3A/I(Cold Plasma)  
 GWH09NA-K3NNB3C/I(Cold Plasma)

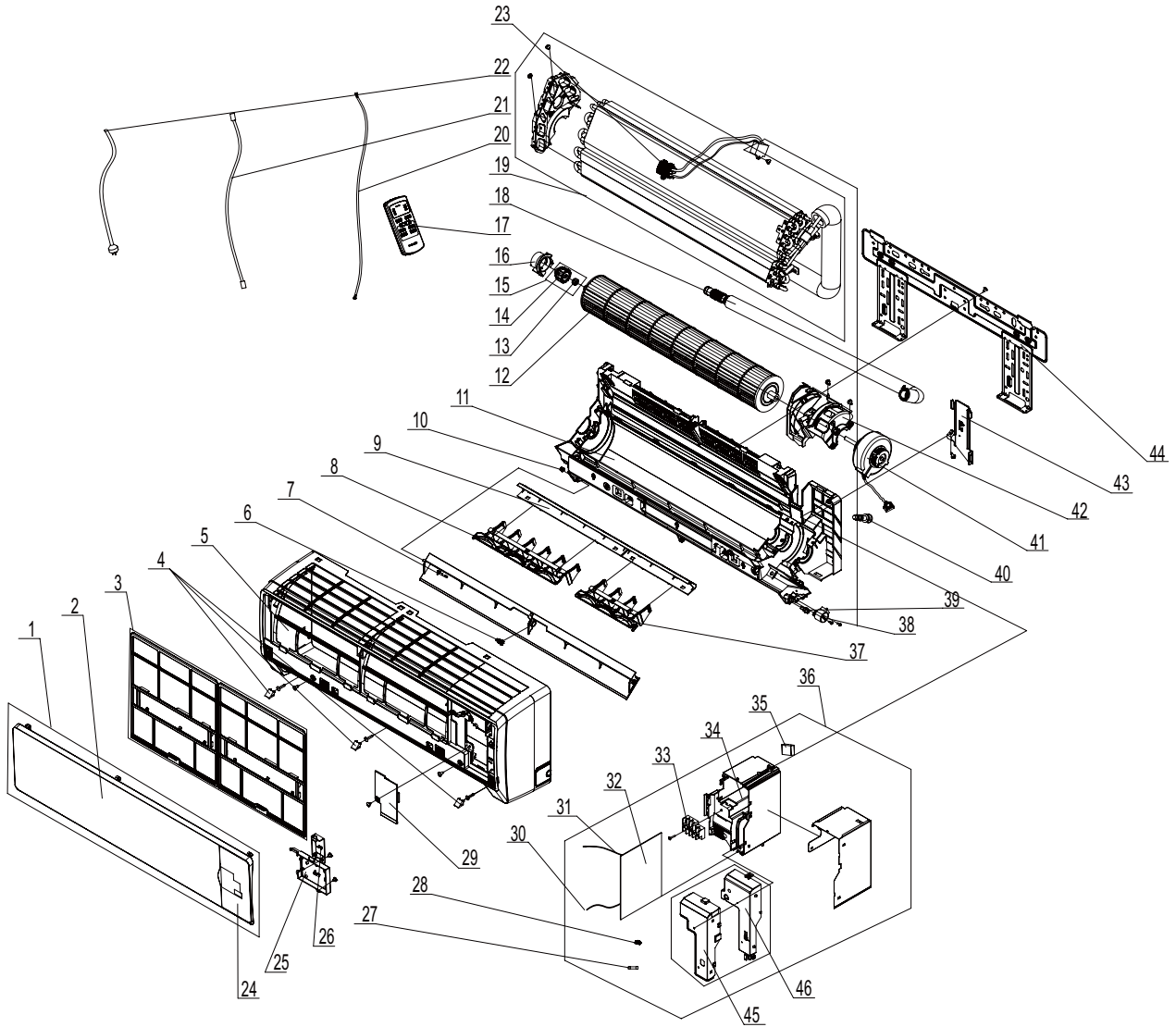

NO.	Description	Part Code			Qty
		GWH07NA-K3NNB3A/I	GWH09NA-K3NNB3A/I	GWH09NA-K3NNB3C/I	
		(Cold Plasma)	(Cold Plasma)	(Cold Plasma)	
Product Code	CA138N03503	CA138N0156	CA138N0322		
1	Front Panel Assy	2001246201	2001246201	20012462	1
2	Front Panel	2001245201	2001245201	20012452S	1
3	Filter Sub-Assy	11122095	11122095	11122095	2
4	Screw Cover	242520175P	242520175P	24252016	3
5	Front Case	2002228606	2002228606	20022286	1
6	Axile Bush	10542036	10542036	10542036	1
7	Guide Louver	1051216202	1051216202	10512162	1
8	Air Louver 2	1051211401	1051211401	10512114	1
9	Helicoid Tongue	2611220201	2611220201	26112202	1
10	Axile Bush	10542704	10542704	10542704	1
11	Rear Case assy	22202293	22202293	22202225	1
12	Cross Flow Fan	10352034	10352034	10352034	1
13	Fan Bearing	76512210	76512210	76512210	1
14	O-Gasket of Cross Fan Bearing	76512203	76512203	76512203	1
15	O-Gasket sub-assy of Bearing	76512051	76512051	76512051	1
16	Ring of Bearing	26152022	26152022	26152022	1
17	Remote Controller	30510065	30510065	30510065	1
18	Drainage Hose	0523001408	0523001408	0523001408	1
19	Evaporator Assy	01002577	01002577	01002577	1
20	Connecting Cable	40020540	40020540	40020540	0
21	Connecting Cable	40020536	40020536	40020536	0
22	Power Cord	400220113	400220113	400220113	1
23	Cold Plasma Generator Sub-assy	11140009	11140009	11140009	1
24	Decorate Piece	68012060	68012060	68012060	1
25	Display Board	30565088	30565088	30565088	1
26	Display Cover	20122122	20122122	20122122	1
27	Fuse	46010055	46010055	46010055	1
28	Jumper	4202300115	4202300114	4202300114	1
29	Electric Box Cover2	2012207520P	2012207520P	20122075	1
30	Ambient Temperature Sensor	390000453	390000453	390000453	1
31	Temperature Sensor	390000597	390000597	390000597	1
32	Main Board	30135357	30135357	30135357	1
33	Terminal Board	42010262	42010262	42010262	1
34	Electric Box	20112091	20112091	20112091	1
35	Capacitor CBB61	33010002	33010002	33010002	1
36	Electric Box Assy	2020227002	20202358	20202358	1
37	Air Louver 1	1051211301	1051211301	10512113	1
38	Step Motor	1521212901	1521212901	1521212901	1
39	Crank	10582070	10582070	10582070	1
40	Rubber Plug (Water Tray)	76712012	76712012	76712012	1
41	Fan Motor	15012115	15012115	15012115	1
42	Motor Press Plate	26112201	26112201	26112201	1
43	Pipe Clamp	2611219901	2611219901	26112199	1
44	Wall Mounting Frame	01252231	01252231	01252231	1
45	ShieldBox (Electric Box)	01592080	01592080	01592080	1
46	Electric Box Cover	20122114	20122114	20122114	1

The data above are subject to change without notice.



## 8.2 Outdoor Unit

Models: GWH07NA-K3NNB1A/O GWH09NB-K3NNE2A/O

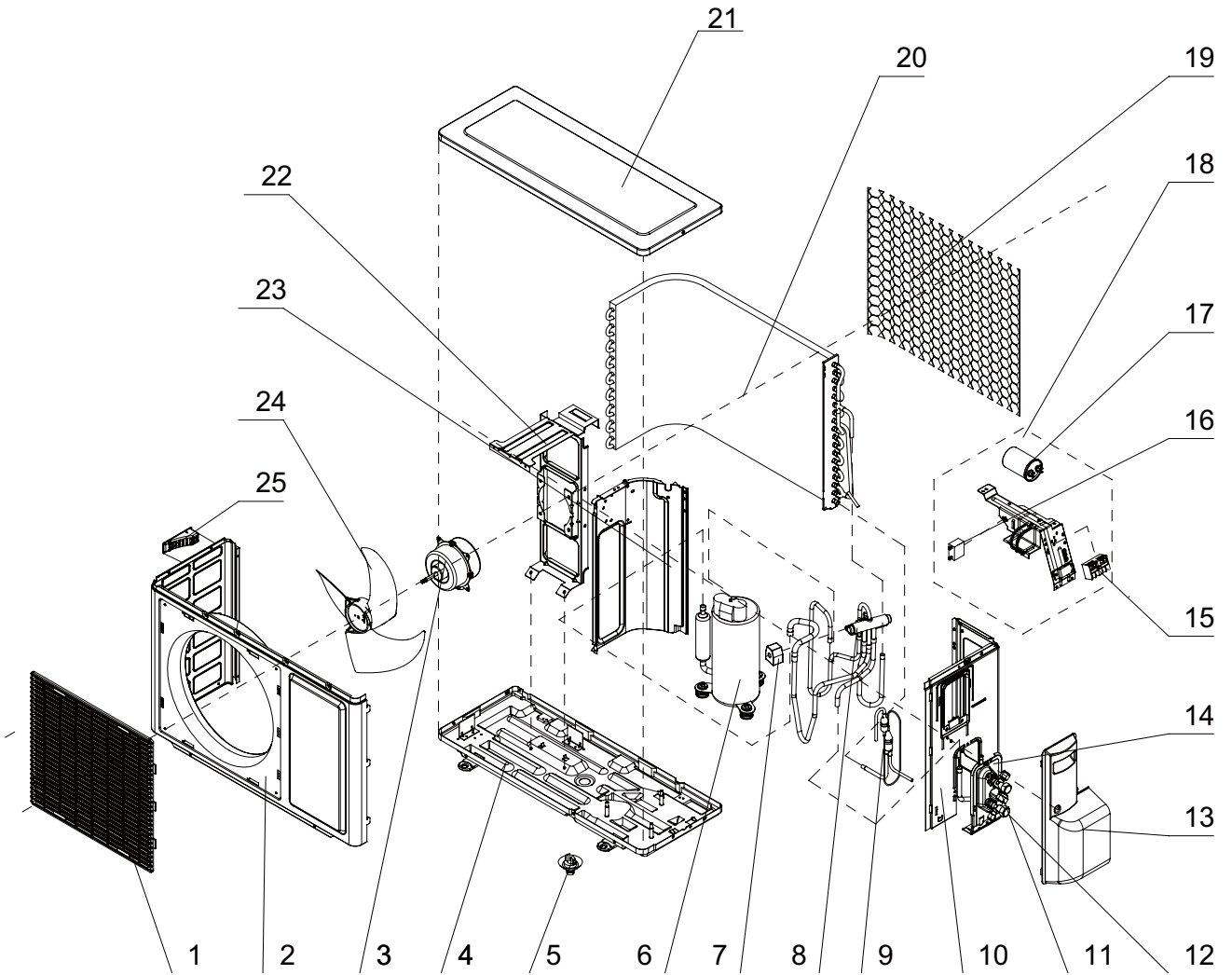

NO.	Description	Part Code		Qty
		GWH07NA-K3NNB1A/O	GWH09NB-K3NNE2A/O	
		Product code		
		CA136W0110	CA401W02900	
1	Front Grill	22263002	22263002	1
2	Front Panel	01533255P	01533255P	1
3	Fan Motor	1501315604	1501315604	1
4	Chassis Sub-assy	01203783P	0280312301P	1
5	Drainage Connector	06123401	06123401	1
6	Compressor and fittings	00101076	00103841	1
7	Magnet Coil	43000400	4300040047	1
8	4-way Valve Assy	03123281	03123972	1
9	Capillary Sub-Assy	03063015	03163076	1
10	Right Side Plate Sub-Assy	01303243	01303243	1
11	Valve	07100003	07130239	1
12	Valve	07100005	07100005	1
13	Big Handle	26233042	26233042	1
14	Valve Support	1713041	01713041	1
15	Terminal Board	42010265	42010265	1
16	Capacitor CBB61	33010020	33010020	1
17	Capacitor CBB65	33000017	33000081	1
18	Electric Box Assy	02603239	02613258	1
19	Rear grill	11123204	11123204	1
20	Condenser Assy	01113467	01163640	1
21	Top Cover Plate	01253027	01253045P	1
22	Motor Support Sub-Assy	01703022	01703054	1
23	Clapboard Sub-Assy	01233107	01233107	1
24	Axial Flow Fan	10333002	10333002	1
25	Small Handle	26233100	26233100	1

The data above are subject to change without notice.

Models:GWH09NA-K3NNB1A/O GWH12NB-K3NNB1A/O

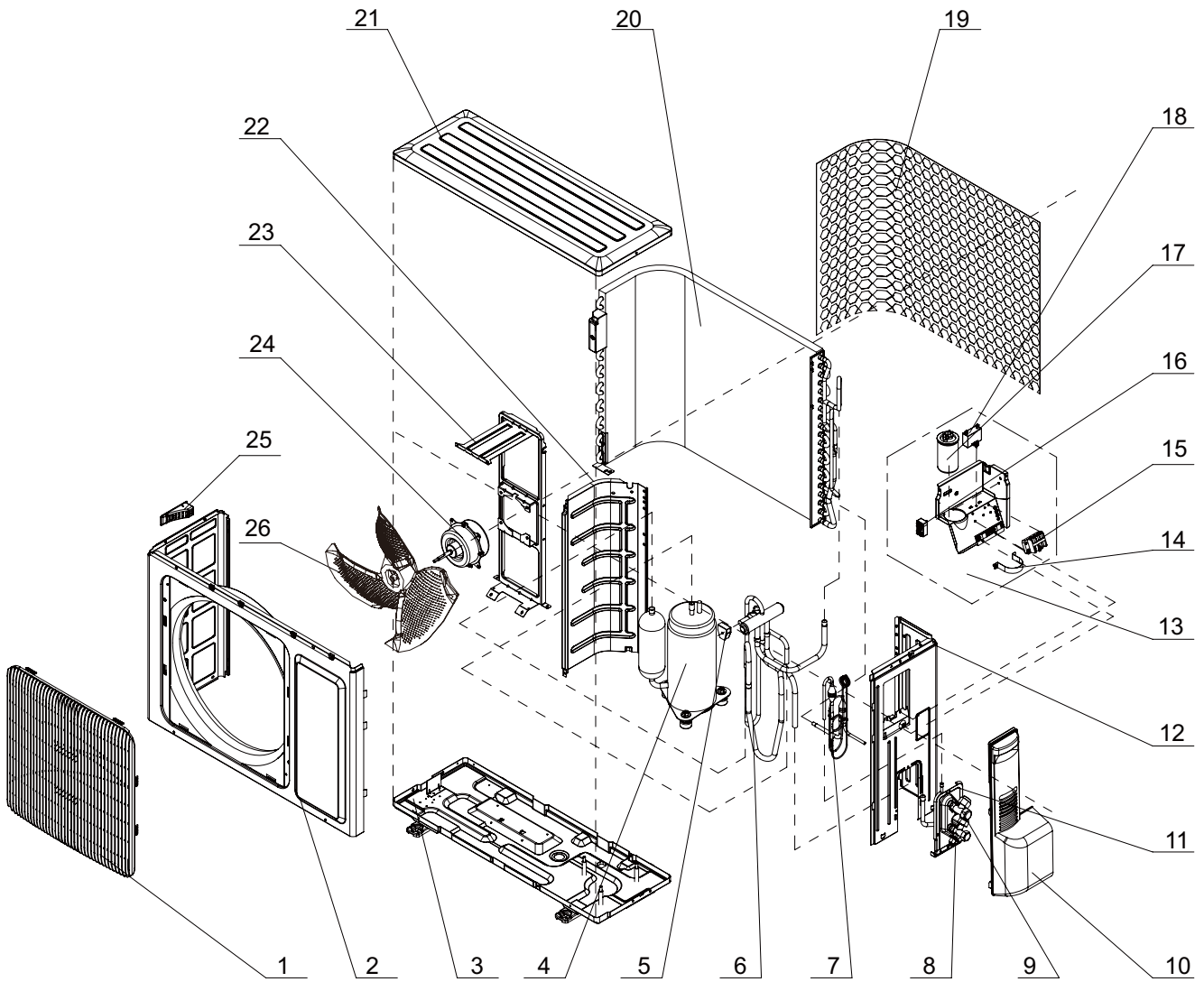

NO.	Description	Part Code		Qty
		GWH09NA-K3NNB1A/O	GWH12NB-K3NNB1A/O	
		Product Code	CA136W0121	
1	Front Grill	22413433	22413431	1
2	Front Panel	01533027P	01533027P	1
3	Chassis Sub-assy	01203799P	01203767P	1
4	Compressor and fittings	00103203	00103764	1
5	Magnet Coil	430004002	430004002	1
6	4-way Valve Assy	03123286	03123341	1
7	Capillary Sub-Assy	0306301701	03103997	1
8	Valve	07100003	07100003	1
9	Valve	07100006	07100006	1
10	Big Handle	26233433	26233433	1
11	Valve Support	0170308901P	0170308901P	1
12	Right Side Plate Sub-Assy	01303183	01303183	1
13	Electric Box Assy	02603240	01403947	1
14	Capacitor clamp sub	02143401	02143401	1
15	Terminal Board	42010265	42010265	1
16	Terminal Board	/	42011147	1
17	Capacitor CBB65	33000018	33010743	1
18	Capacitor CBB61	33010026	33010026	1
19	Rear grill	1112320501	1112320501	1
20	Condenser Assy	0111347201	01113449	1
21	Top Cover Sub-Assy	01253031	01253031	1
22	Clapboard Sub-Assy	01233066	01233066	1
23	Motor Support	01703058	01703058	1
24	Fan Motor	150130671	150130676	1
25	Small Handle	26233100	26233100	1
26	Axial Flow Fan	10333004	10333004	1

The data above are subject to change without notice.

Models:GWH09NA-K3NNB1A/O GWH09NA-K3NNB1C/O GWH12NB-K3NNB1C/O

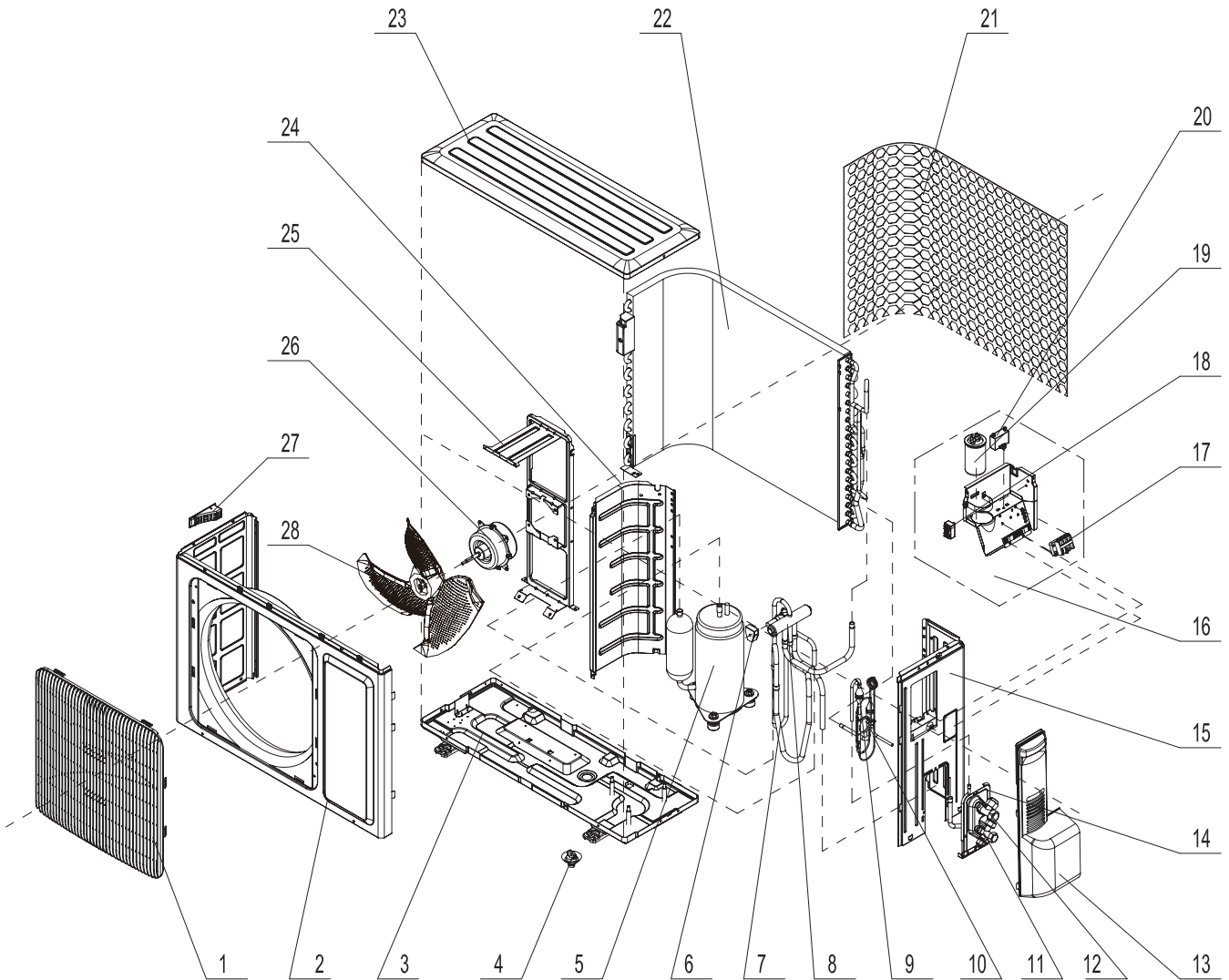

NO.	Description	Part Code			Qty
		GWH09NA-K3NNB1A/O	GWH09NA-K3NNB1C/O	GWH12NB-K3NNB1C/O	
	Product Code	CA136W0122	CA136W06900	CA136W07000	
1	Front grill	22413433	22413433	22413433	1
2	Front Panel	01533033P	01533033P	01533027P	1
3	Chassis Sub-assy	01203799P	01203748P	01203767P	1
4	Drainage Connector	06123401	06123401	06123401	1
5	Compressor and fittings	00103203	00103804	00103764	1
6	Magnet Coil	430004002	430004002	430004002	1
7	4-way Valve Assy	0312328601	03123646	03123642	1
8	4-way Valve	430004022	430004022	430004032	1
9	StrainerA	07210022	07210022	07210022	1
10	Capillary Sub-Assy	0306301701	03063533	03103997	1
11	Valve	07100005	07100005	07100005	1
12	Valve	07100003	07100003	07100003	1
13	Big Handle	26233433	26233433	26233433	1
14	Valve Support	0170308901P	0170308901P	0170308901P	1
15	Right Side Plate Sub-Assy	01303183	01303183	01303183	1
16	Electric Box Assy	02603240	02603599	02603597	1
17	Terminal Board	42010265	42010265	42010265	1
18	Terminal Board	/	/	/	/
19	Capacitor CBB65	33000018	33000017	33010743	1
20	Capacitor CBB61	33010026	33010026	33010026	1
21	Rear grill	1112320501	1112320501	1112320501	1
22	Condenser Assy	0111347201	01163041	01163034	1
23	Top Cover Sub-Assy	01253031	01253031	01253031	1
24	Clapboard Sub-Assy	01233066	01233066	01233066	1
25	Motor Support	01703102	01703104	01703058	1
26	Fan Motor	150130671	150130671	150130676	1
27	Small Handle	26233100	26233100	26233100	1
28	Axial Flow Fan	10333427	10333427	10333004	1

The data above are subject to change without notice.

## 9. Troubleshooting

### 9.1 Troubleshooting

Be cautious during installation and maintenance. Do operation following the regulations to avoid electric shock and casualty or even death due to drop from high attitude.

\* Static maintenance is the maintenance during de-energization of the air conditioner.

For static maintenance, make sure that the unit is de-energized and the plug is disconnected.

\*dynamic maintenance is the maintenance during energization of the unit.

Before dynamic maintenance, check the electricity and ensure that there is ground wire on the site. Check if there is electricity on the housing and connection copper pipe of the air conditioner with voltage tester. After ensure insulation place and the safety, the maintenance can be performed.

Take sufficient care to avoid directly touching any of the circuit parts without first turning off the power. At times such as when the circuit board is to be replaced, place the circuit board assembly in a vertical position. Normally, diagnose troubles according to the trouble diagnosis procedure as described below. (Refer to the check points in servicing written on the wiring diagrams attached to the indoor/outdoor units.)

NO.	Troubleshooting procedure
1	Confirmation
2	Judgement by Flashing LED of Indoor/Outdoor Unit
3	How to Check simply the main part

### 9.2 Confirmation

#### (1) Confirmation of Power Supply

Confirm that the power breaker operates (ON) normally;

#### (2) Confirmation of Power Voltage

Confirm that power voltage is AC 220–230–240 ± 10%. If power voltage is not in this range, the unit may not operate normally.

### 9.3 Judgement by Flashing LED of Indoor/Outdoor Unit

No.	Malfunction Name	Error Code	Display Method of Indoor Unit			A/C Status	Possible Causes
			Indicator lamp(During blinking,ON for 0.5S and OFF for 0.5S)				
			Operation Lamp.	COOL Lamp.	HEAT Lamp		
1	Indoor ambient temperature sensor is open/short-circuited	F1		OFF 3S and blinks once		The unit will stop operation as it reaches the temperature point.During cooling and drying operation, except indoor fan operates,other loads (such as compressor,outdoor fan,4-way valve) stop operation; During heating operation, the complete unit stops operation.	1.The wiring terminal between indoor ambient temperature sensor and controller is loosened or poorly contacted; 2.There's short circuit due to trip-over of the parts on controller; 3.Indoor ambient temperature sensor is damaged(Please check it by referring to the resistance table for temperature sensor) 4.Main board is broken
2	Indoor evaporator temperature sensor is open/short-circuited	F2		OFF 3S and blinks twice		The unit will stop operation as it reaches the temperature point.During cooling and drying operation,except indoor fan operates,other loads stop operation;During heating operation,the complete unit stops operation	1.The wiring terminal between indoor evaporator temperature sensor and controller is loosened or poorly contacted; 2.There's short circuit due to the trip-over of the parts on controller; 3.Indoor evaporator temperature sensor is damaged (Please check it by referring to the resistance table for temperature sensor). 4.Main board is broken.
3	PG motor (indoor fan motor)does not operate	H6	OFF 3S and blinks 11 times			Indoor fan, outdoor fan, compressor and electric heat tube stop operation 2 minutes later,4-way valve stops; horizontal louver stops at the current position.	1.The feedback terminal of PG motor is not connected tightly. 2.The control terminal of PG motor is not connected tightly. 3.Fan blade rotates unsmoothly due to improper installation. 4.Motor is not installed properly and tightly. 5.Motor is damaged. 6.Controller is damaged.
4	Malfunction protection of jumper cap	C5	OFF 3S and blinks 15 times			Operation of remote controller. or control panel is available, but the unit won't act.	1.There's not jumper cap on the controller. 2.Jumper cap is not inserted properly and tightly. 3.Jumper cap is damaged. 4..Controller is damaged.
5	PG motor(indoor fan)circuit malfunction by zero cross detection	U8	OFF 3S and blinks 17 times			Operation of remote controller or control panel is available,but the unit won't act.	1.Controller is damaged.



## 9.4 How to Check Simply the MainPart

### 9.4.1. Malfunction of temperature sensor

Malfunction diagnosis flowchart:

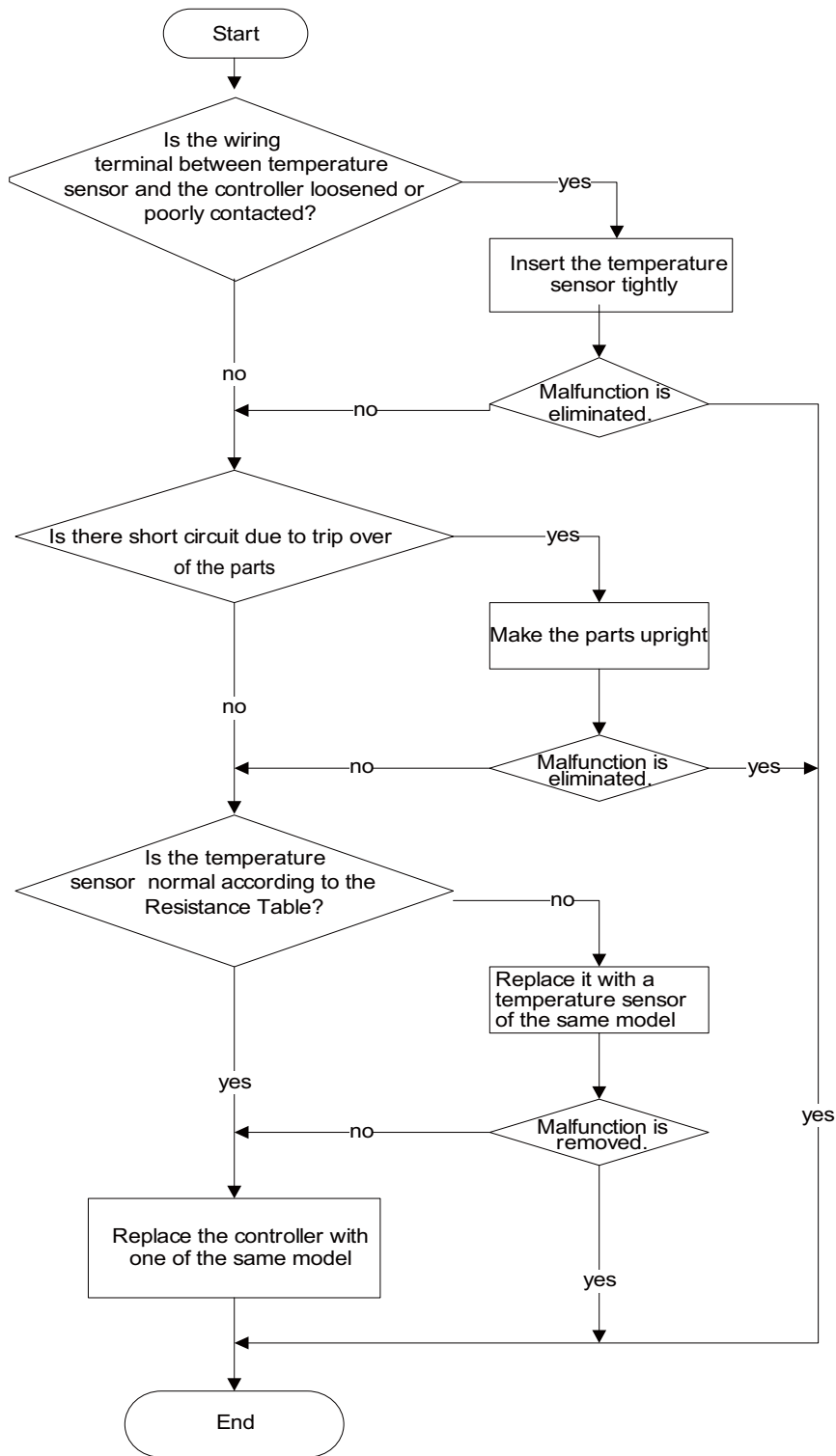

### 9.4.2 C5 Malfunction

Possible causes:

1. There is no jumper cap on the controller;
  2. Jumper cap is not inserted properly and tightly;
  3. Jumper cap is damaged;
  4. Controller is damaged.
- See the flow chart below:

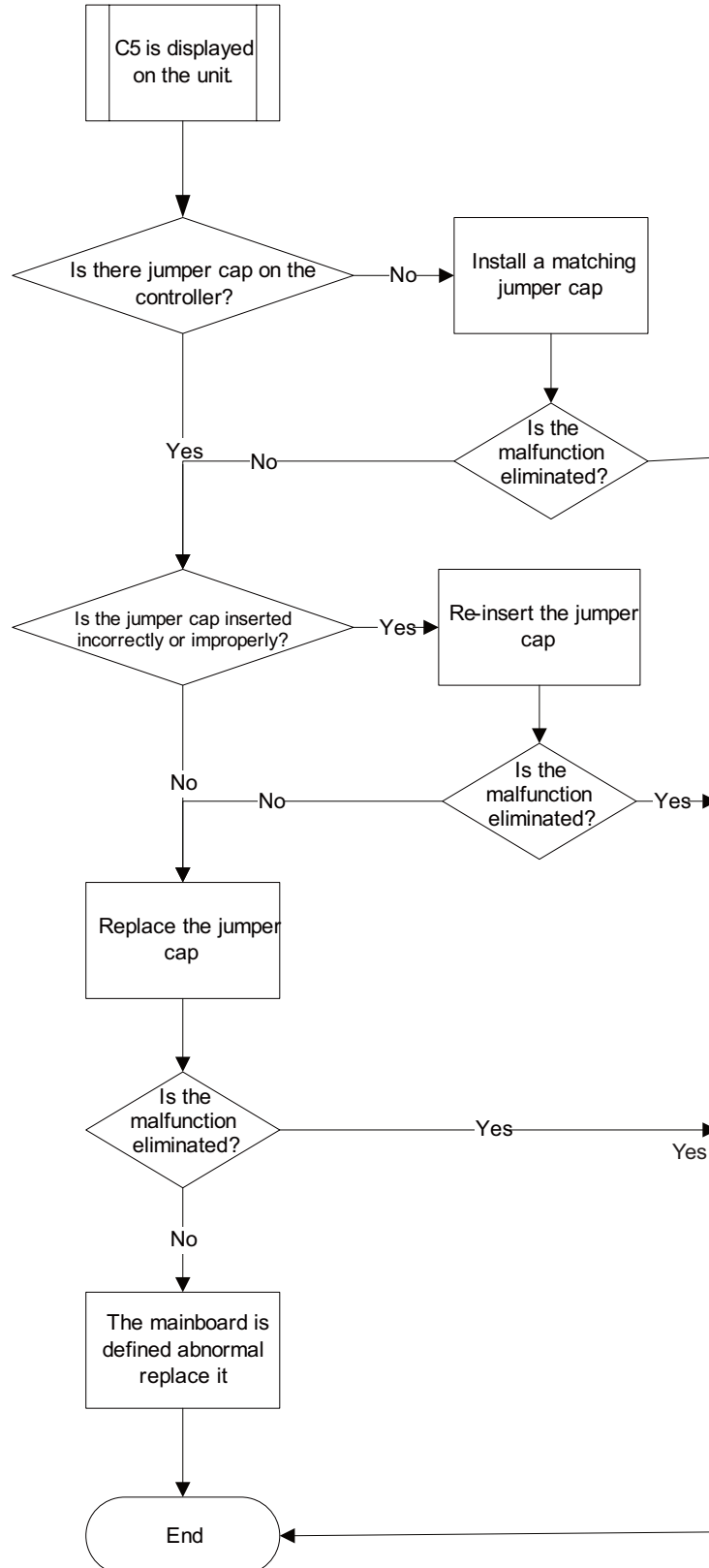

### 9.4.3 H6 Malfunction

Possible causes:

1. Fan motor is locked;
2. The feedback terminal of PG motor is not connected tightly;
3. The control terminal of PG motor is not connected tightly;
4. Motor is damaged;
5. Malfunction of the rotation speed detection circuit of the mainboard.

See the flow chart below:

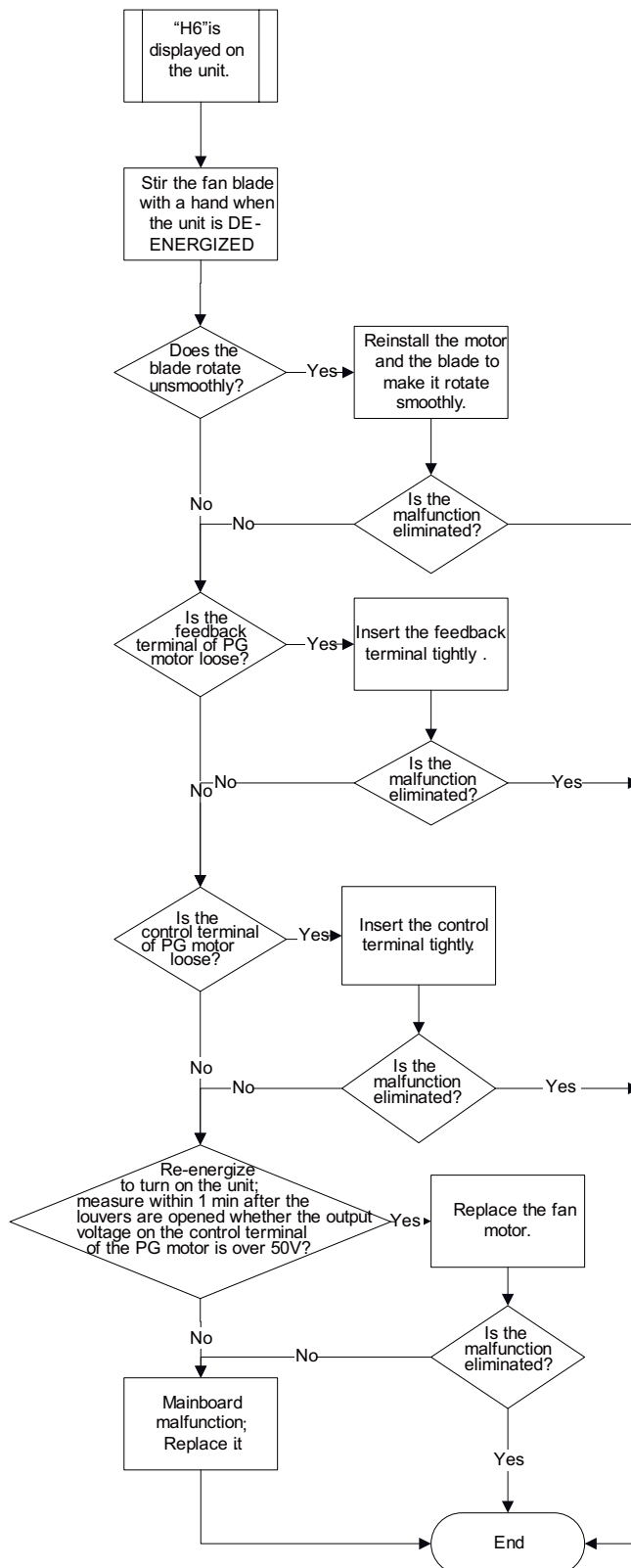

### 9.4.4 U8 Malfunction

Possible causes:

1. The controller diagnoses incorrectly due to instant energization after de-energized while the capacitor discharges slowly;
2. Malfunction of the zero-cross detection circuit of the mainboard.

See the flow chart below;

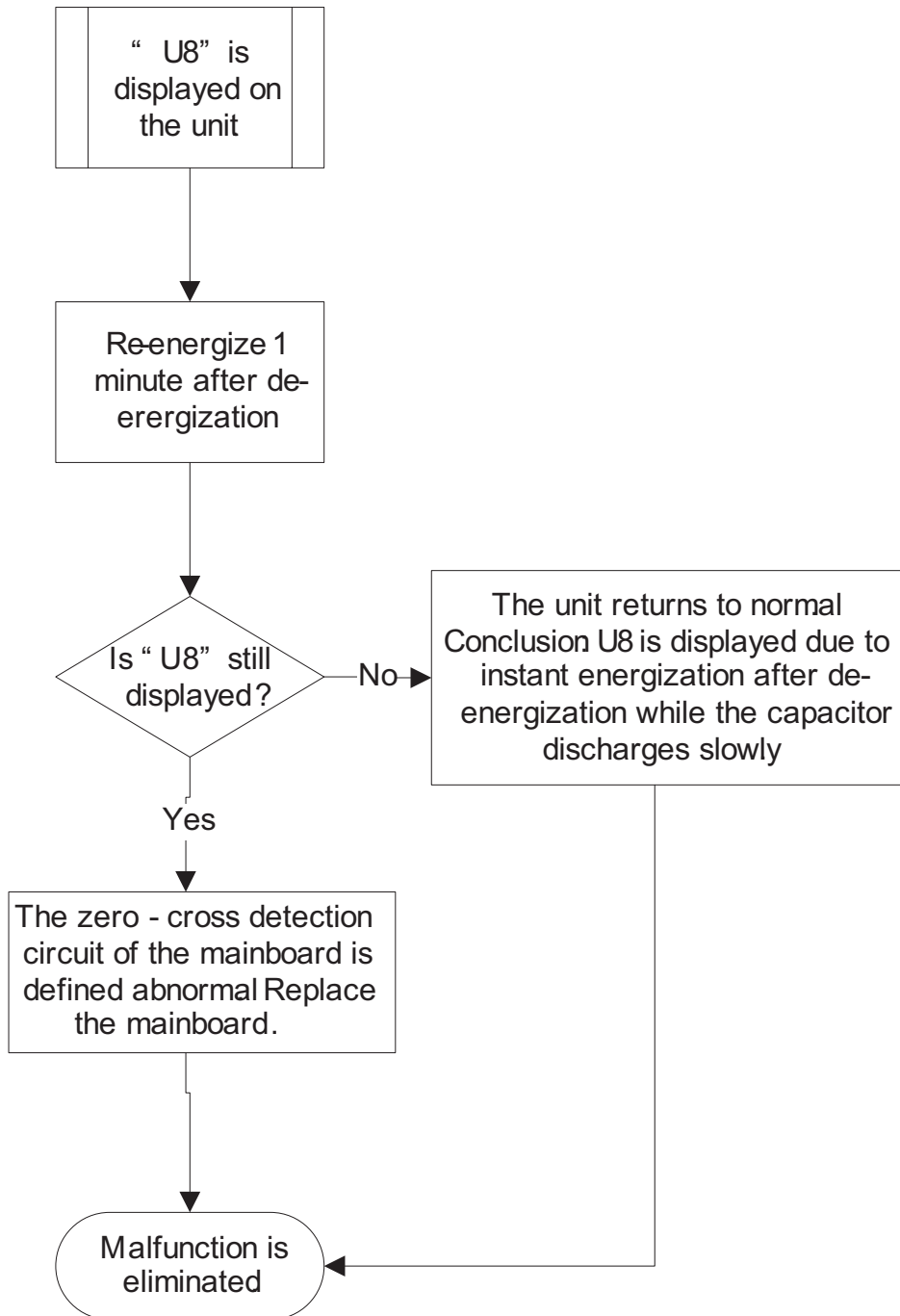

Appendix 1: Resistance Table for Indoor and Outdoor Ambient Temperature Sensors (15K)							
Temp.( °C )	Resistance( kΩ )	Temp.( °C )	Resistance( kΩ )	Temp.( °C )	Resistance( kΩ )	Temp.( °C )	Resistance( kΩ )
-19	138.1	20	18.75	59	3.848	98	1.071
-18	128.6	21	17.93	60	3.711	99	1.039
-17	121.6	22	17.14	61	3.579	100	1.009
-16	115	23	16.39	62	3.454	101	0.98
-15	108.7	24	15.68	63	3.333	102	0.952
-14	102.9	25	15	64	3.217	103	0.925
-13	97.4	26	14.36	65	3.105	104	0.898
-12	92.22	27	13.74	66	2.998	105	0.873
-11	87.35	28	13.16	67	2.896	106	0.848
-10	82.75	29	12.6	68	2.797	107	0.825
-9	78.43	30	12.07	69	2.702	108	0.802
-8	74.35	31	11.57	70	2.611	109	0.779
-7	70.5	32	11.09	71	2.523	110	0.758
-6	66.88	33	10.63	72	2.439	111	0.737
-5	63.46	34	10.2	73	2.358	112	0.717
-4	60.23	35	9.779	74	2.28	113	0.697
-3	57.18	36	9.382	75	2.206	114	0.678
-2	54.31	37	9.003	76	2.133	115	0.66
-1	51.59	38	8.642	77	2.064	116	0.642
0	49.02	39	8.297	78	1.997	117	0.625
1	46.6	40	7.967	79	1.933	118	0.608
2	44.31	41	7.653	80	1.871	119	0.592
3	42.14	42	7.352	81	1.811	120	0.577
4	40.09	43	7.065	82	1.754	121	0.561
5	38.15	44	6.791	83	1.699	122	0.547
6	36.32	45	6.529	84	1.645	123	0.532
7	34.58	46	6.278	85	1.594	124	0.519
8	32.94	47	6.038	86	1.544	125	0.505
9	31.38	48	5.809	87	1.497	126	0.492
10	29.9	49	5.589	88	1.451	127	0.48
11	28.51	50	5.379	89	1.408	128	0.467
12	27.18	51	5.197	90	1.363	129	0.456
13	25.92	52	4.986	91	1.322	130	0.444
14	24.73	53	4.802	92	1.282	131	0.433
15	23.6	54	4.625	93	1.244	132	0.422
16	22.53	55	4.456	94	1.207	133	0.412
17	21.51	56	4.294	95	1.171	134	0.401
18	20.54	57	4.139	96	1.136	135	0.391
19	19.63	58	3.99	97	1.103	136	0.382

Appendix 2: Resistance Table for Indoor and Outdoor Tube Temperature Sensor (20K)							
Temp.(°C)	Resistance (kΩ)	Temp. (°C)	Resistance (kΩ)	Temp. (°C)	Resistance (kΩ)	Temp. (°C)	Resistance (kΩ)
-19	181.4	20	25.01	59	5.13	98	1.427
-18	171.4	21	23.9	60	4.948	99	1.386
-17	162.1	22	22.85	61	4.773	100	1.346
-16	153.3	23	21.85	62	4.605	101	1.307
-15	145	24	20.9	63	4.443	102	1.269
-14	137.2	25	20	64	4.289	103	1.233
-13	129.9	26	19.14	65	4.14	104	1.198
-12	123	27	18.13	66	3.998	105	1.164
-11	116.5	28	17.55	67	3.861	106	1.131
-10	110.3	29	16.8	68	3.729	107	1.099
-9	104.6	30	16.1	69	3.603	108	1.069
-8	99.13	31	15.43	70	3.481	109	1.039
-7	94	32	14.79	71	3.364	110	1.01
-6	89.17	33	14.18	72	3.252	111	0.983
-5	84.61	34	13.59	73	3.144	112	0.956
-4	80.31	35	13.04	74	3.04	113	0.93
-3	76.24	36	12.51	75	2.94	114	0.904
-2	72.41	37	12	76	2.844	115	0.88
-1	68.79	38	11.52	77	2.752	116	0.856
0	65.37	39	11.06	78	2.663	117	0.833
1	62.13	40	10.62	79	2.577	118	0.811
2	59.08	41	10.2	80	2.495	119	0.77
3	56.19	42	9.803	81	2.415	120	0.769
4	53.46	43	9.42	82	2.339	121	0.746
5	50.87	44	9.054	83	2.265	122	0.729
6	48.42	45	8.705	84	2.194	123	0.71
7	46.11	46	8.37	85	2.125	124	0.692
8	43.92	47	8.051	86	2.059	125	0.674
9	41.84	48	7.745	87	1.996	126	0.658
10	39.87	49	7.453	88	1.934	127	0.64
11	38.01	50	7.173	89	1.875	128	0.623
12	36.24	51	6.905	90	1.818	129	0.607
13	34.57	52	6.648	91	1.736	130	0.592
14	32.98	53	6.403	92	1.71	131	0.577
15	31.47	54	6.167	93	1.658	132	0.563
16	30.04	55	5.942	94	1.609	133	0.549
17	28.68	56	5.726	95	1.561	134	0.535
18	27.39	57	5.519	96	1.515	135	0.521
19	26.17	58	5.32	97	1.47	136	0.509

Appendix 3: Resistance Table for Outdoor Discharge Temperature Sensor (50K)							
Temp. (°C)	Resistance (kΩ)	Temp. (°C)	Resistance(kΩ)	Temp. (°C)	Resistance (kΩ)	Temp. (°C)	Resistance (kΩ)
-29	853.5	10	98	49	18.34	88	4.754
-28	799.8	11	93.42	50	17.65	89	4.609
-27	750	12	89.07	51	16.99	90	4.469
-26	703.8	13	84.95	52	16.36	91	4.334
-25	660.8	14	81.05	53	15.75	92	4.204
-24	620.8	15	77.35	54	15.17	93	4.079
-23	580.6	16	73.83	55	14.62	94	3.958
-22	548.9	17	70.5	56	14.09	95	3.841
-21	516.6	18	67.34	57	13.58	96	3.728
-20	486.5	19	64.33	58	13.09	97	3.619
-19	458.3	20	61.48	59	12.62	98	3.514
-18	432	21	58.77	60	12.17	99	3.413
-17	407.4	22	56.19	61	11.74	100	3.315
-16	384.5	23	53.74	62	11.32	101	3.22
-15	362.9	24	51.41	63	10.93	102	3.129
-14	342.8	25	49.19	64	10.54	103	3.04
-13	323.9	26	47.08	65	10.18	104	2.955
-12	306.2	27	45.07	66	9.827	105	2.872
-11	289.6	28	43.16	67	9.489	106	2.792
-10	274	29	41.34	68	9.165	107	2.715
-9	259.3	30	39.61	69	8.854	108	2.64
-8	245.6	31	37.96	70	8.555	109	2.568
-7	232.6	32	36.38	71	8.268	110	2.498
-6	220.5	33	34.88	72	7.991	111	2.431
-5	209	34	33.45	73	7.726	112	2.365
-4	198.3	35	32.09	74	7.47	113	2.302
-3	199.1	36	30.79	75	7.224	114	2.241
-2	178.5	37	29.54	76	6.998	115	2.182
-1	169.5	38	28.36	77	6.761	116	2.124
0	161	39	27.23	78	6.542	117	2.069
1	153	40	26.15	79	6.331	118	2.015
2	145.4	41	25.11	80	6.129	119	1.963
3	138.3	42	24.13	81	5.933	120	1.912
4	131.5	43	23.19	82	5.746	121	1.863
5	125.1	44	22.29	83	5.565	122	1.816
6	119.1	45	21.43	84	5.39	123	1.77
7	113.4	46	20.6	85	5.222	124	1.725
8	108	47	19.81	86	5.06	125	1.682
9	102.8	48	19.06	87	4.904	126	1.64

Note: The information above is for reference only.

# 10. Removal Procedure

## 10.1 Removal Procedure of Indoor Unit

 **Warning** Be sure to wait for a minimum of 10 minutes after turning off all power supplies before disassembly.

Take A2 panel for example

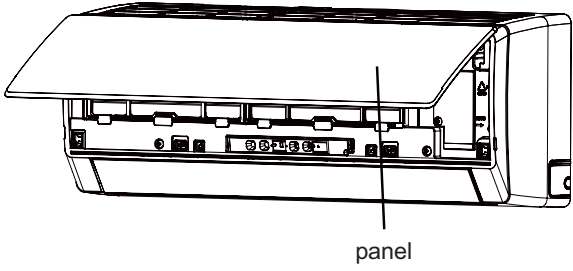
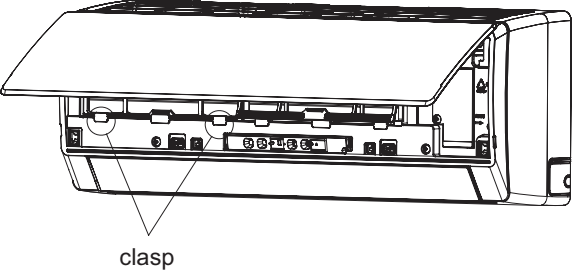
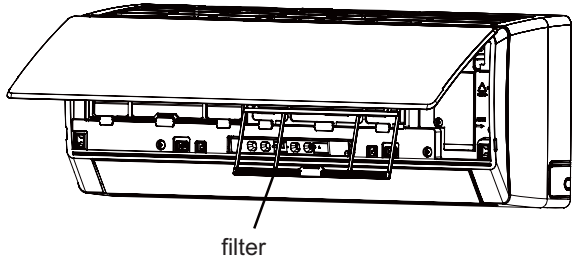
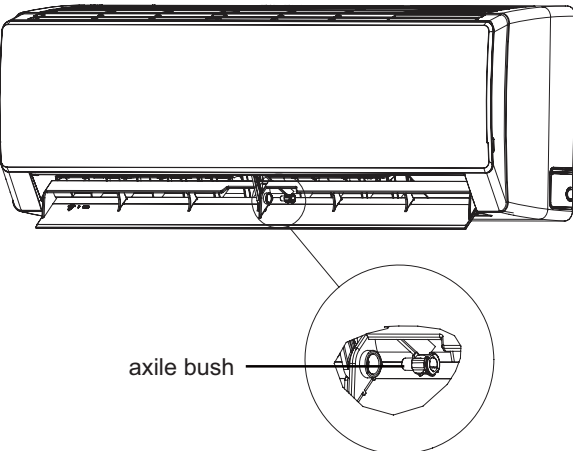
Step	Procedure	
1.Remove the filter		  
2.Remove the horizontal louver		
1	Remove the axile bush on the horizontal louver.	

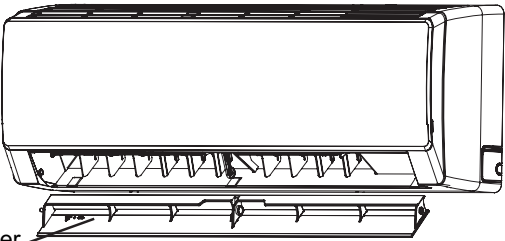
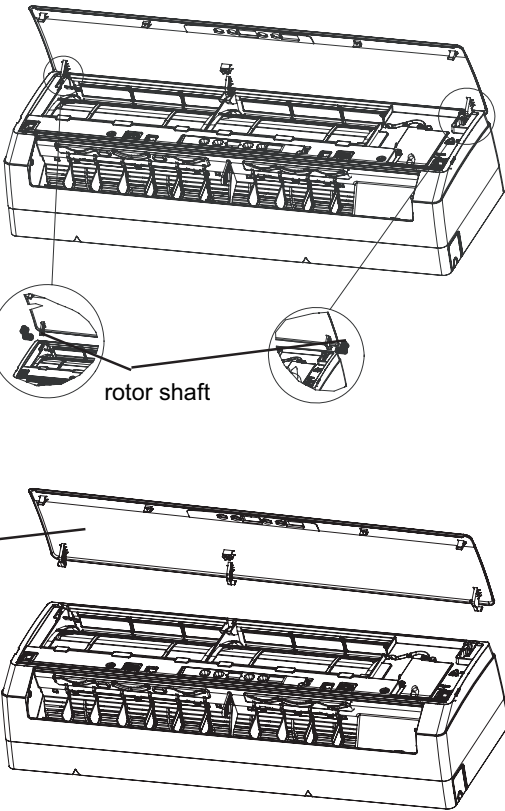
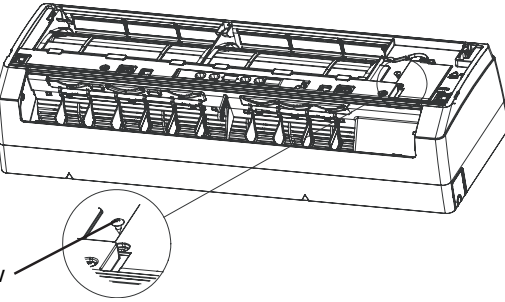

Step	Procedure	
2	Pull the horizontal louver outward to remove it.	 <p data-bbox="783 562 959 584">horizontal louver</p>
3. Remove the panel		 <p data-bbox="1038 1066 1150 1088">rotor shaft</p> <p data-bbox="847 1211 911 1234">panel</p>
4. Remove the electric box cover		 <p data-bbox="879 1906 943 1928">screw</p>
1	Loosen the screws of the electric box cover.	

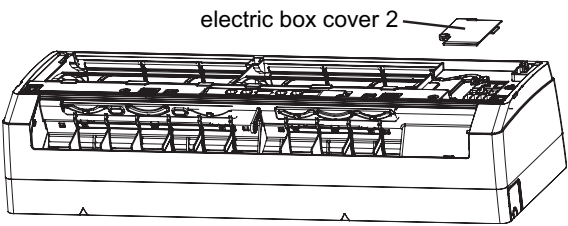
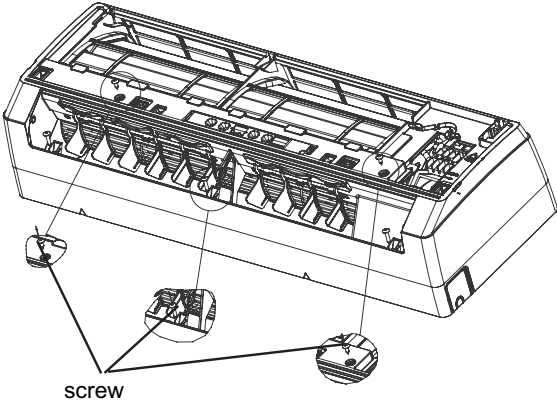
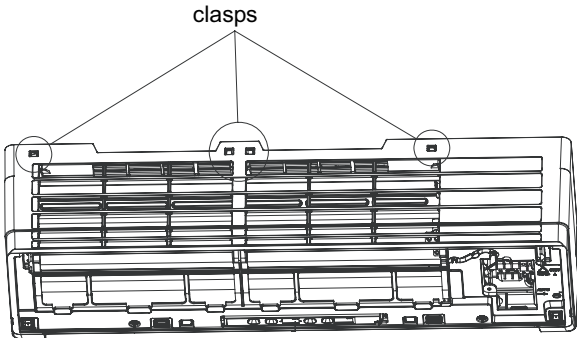
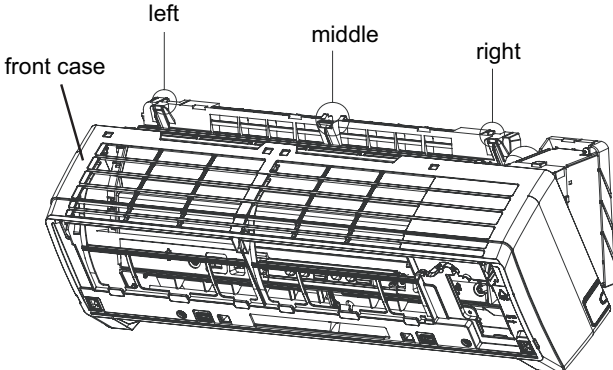
Step	Procedure	
2	Remove the electric box cover.	
5.Remove the front case		
1	Open the screw cap on the front case. Remove the screws fixing the front case.	
2	Loosen the clasps of the front case.	
3	Remove the front case.	

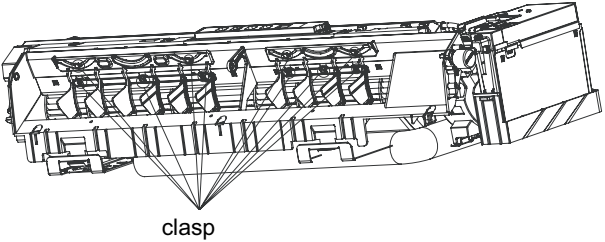
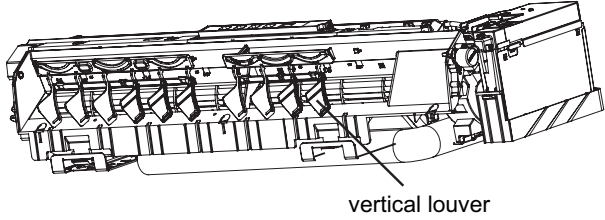
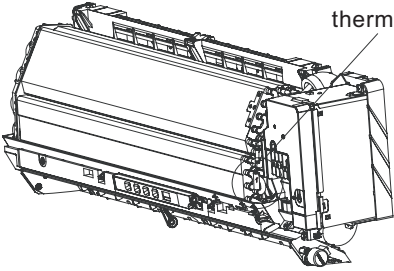
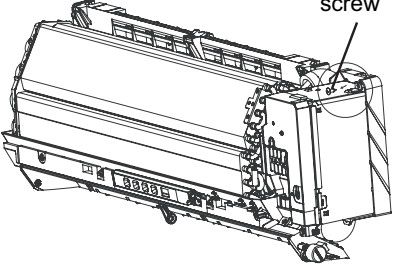
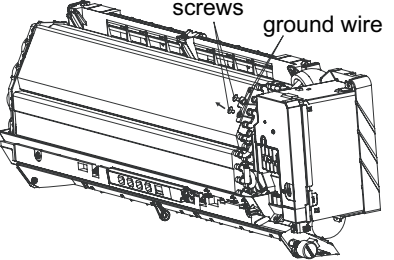
Step	Procedure	
6.Remove the vertical louver		
1	Loosen the clasp connecting the vertical louver and bottom case subassembly.	 <p style="text-align: center;">clasp</p>
2	Remove the vertical louver.	 <p style="text-align: center;">vertical louver</p>
7.Remove the electric box		
1	Disconnect the indoor tube temperature sensor.	 <p style="text-align: right;">heat exchanger thermistor</p>
2	Remove the screws of the electric box.	 <p style="text-align: right;">screw</p>
3	Remove the screws at the joint of the ground wire and evaporator.	 <p style="text-align: right;">screws ground wire</p>

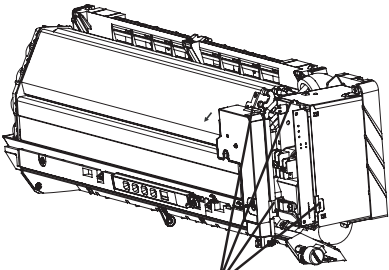
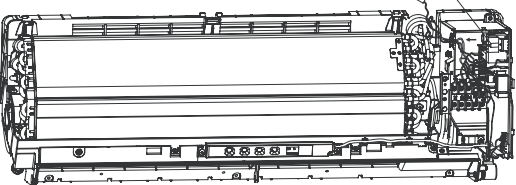
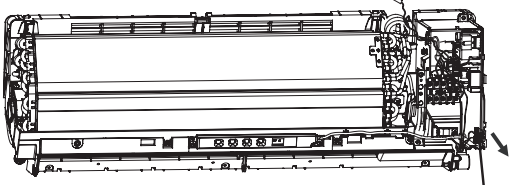
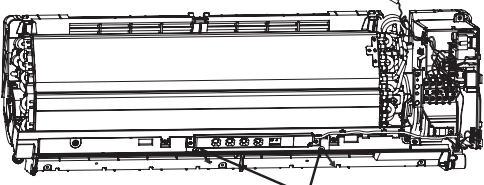
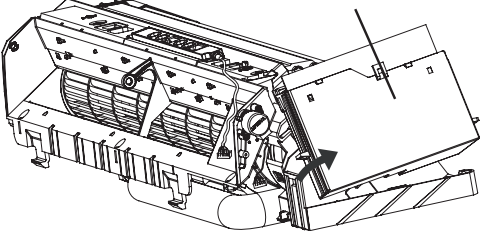
Step	Procedure	
4	Loosen the clasp at the joint of the electric box cover and the electric box.	 <p>clasp</p>
5	Disconnect the plug of the motor.	 <p>fan motor signal wire</p>
6	Disconnect the plug of step motor.	 <p>plug of step motor</p>
7	Remove the 2 screws of the display.	 <p>screws</p>
8	Remove the electric box.	 <p>electric box</p>

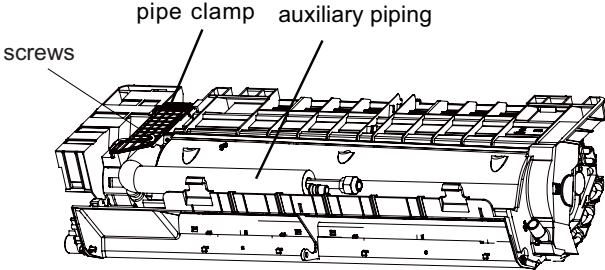
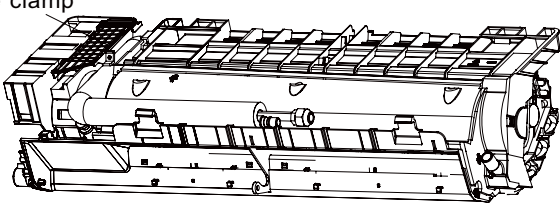
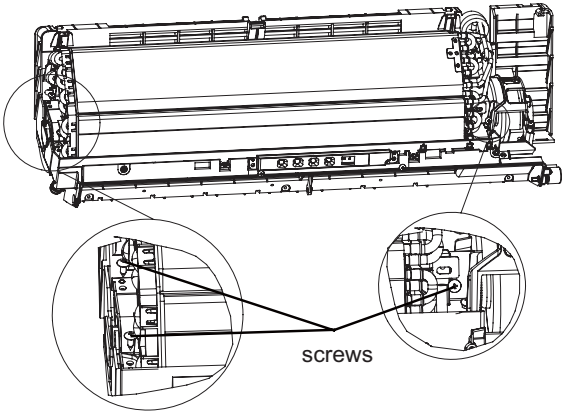
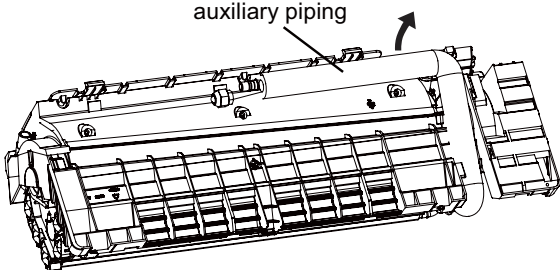
Step	Procedure	
8.Remove pipe clamp of connecting pipe		
1	Remove the screws of the pipe clamp of connecting pipe.	
2	Remove pipe clamp of connecting pipe.	
9.Remove the evaporator		
1	Remove the screws at the joint of the evaporator and bottom case.	
2	Adjust the pipe slightly to separate the connecting pipe and the evaporator.	

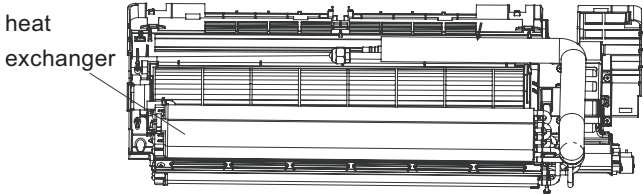
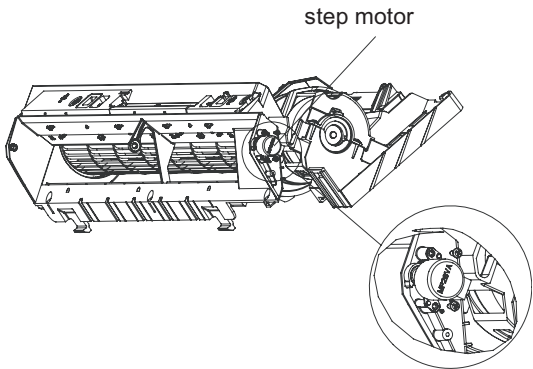
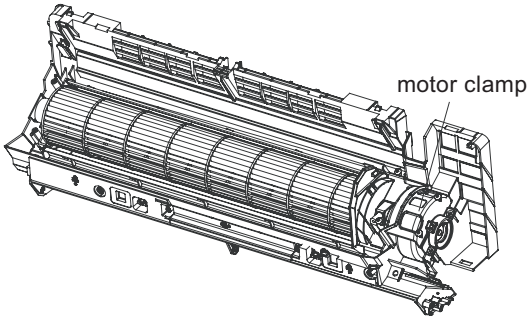
Step	Procedure	
3	Remove the evaporator.	
10.Remove motor and cross flow fan		
1	Remove the screw of the step motor and remove the step motor.	
2	Remove the screw of the motor clamp. Remove the press plate.	

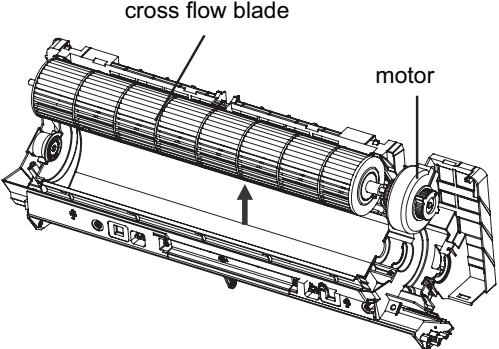
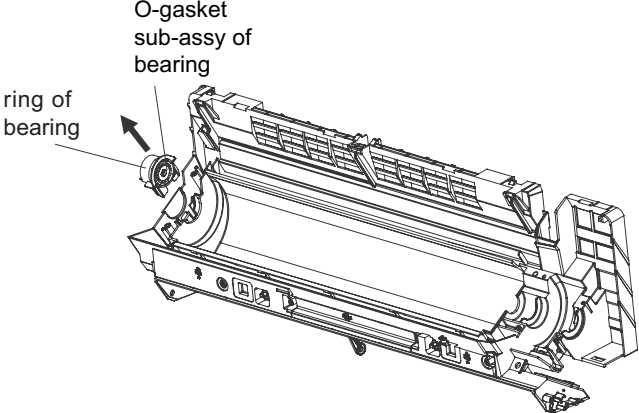
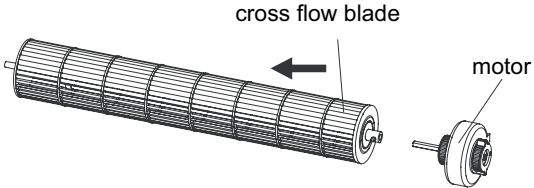
Step	Procedure	Procedure
3	Remove the cross flow blade and motor.	 <p>A perspective view of the main unit with the cross flow blade and motor assembly being lifted upwards. An upward-pointing arrow is positioned between the blade and the main unit. Labels 'cross flow blade' and 'motor' point to their respective parts.</p>
4	Remove the rubber cushion of the bearing.	 <p>A perspective view of the main unit with the bearing assembly being removed. An arrow points to the 'O-gasket sub-assy of bearing' and another arrow points to the 'ring of bearing'.</p>
5	Remove the screws at the joint of the cross flow blade and the motor. Take down the motor.	 <p>A perspective view showing the 'cross flow blade' and 'motor' separated. An arrow points from the motor towards the blade, indicating the direction of removal.</p>

## 10.2 Removal Procedure of Outdoor Unit

**⚠ Warning** Be sure to wait for a minimum of 10 minutes after turning off all power supplies before disassembly.

(1) GWH07NA-K3NNB1A/O GWH09NB-K3NNE2A/O

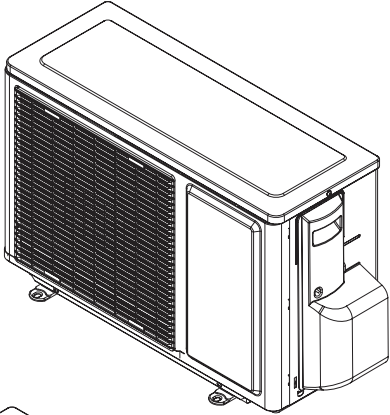
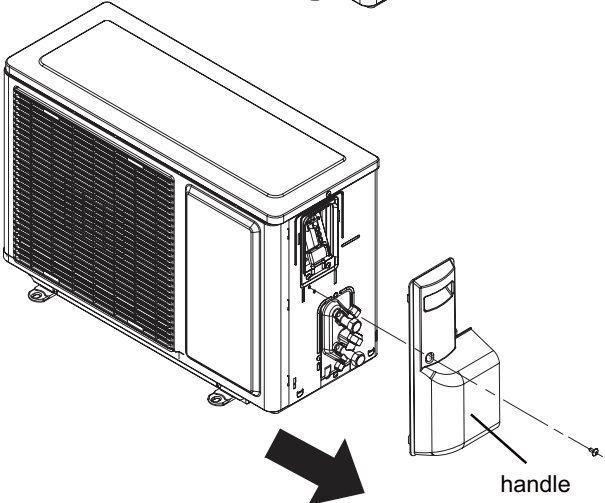
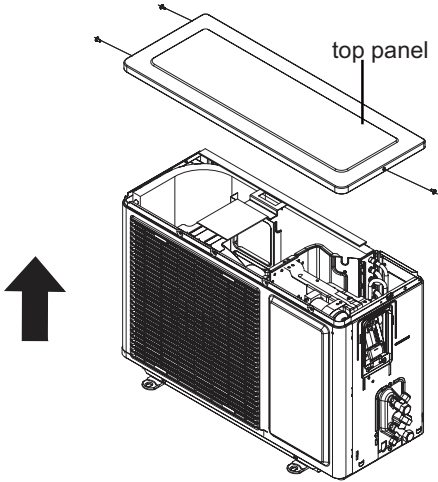
Step	Procedure	
<b>1. Remove big handle</b>		
a	Before disassembly.	
b	Remove the screw fixing the big handle. Remove the big handle.	
<b>2. Remove top panel</b>		
	Remove the 3 screws connecting the top panel with the front panel and the right side panel. Remove the top cover.	

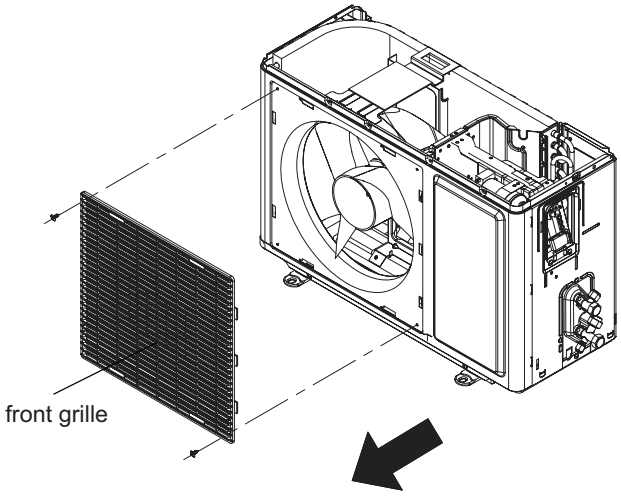
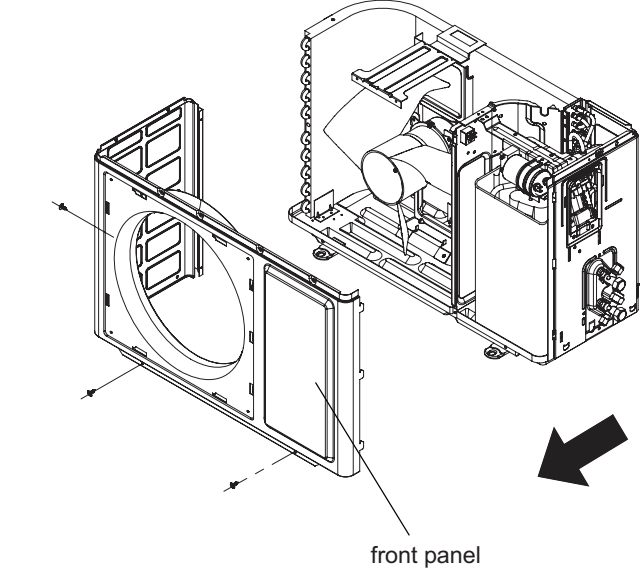
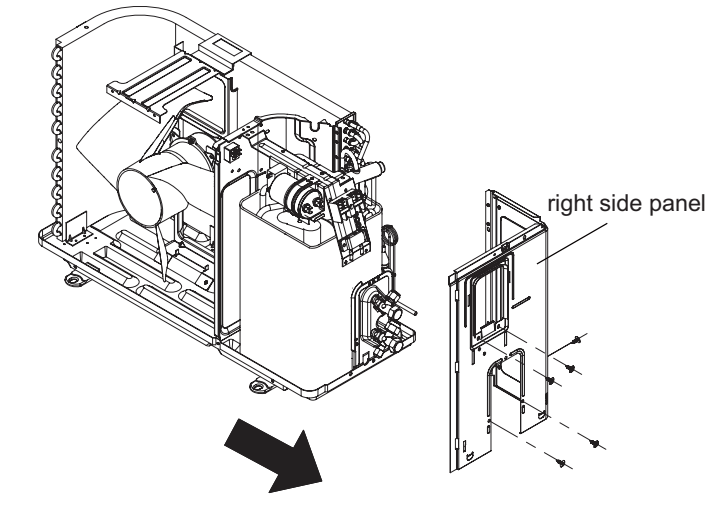

Step	Procedure	
<b>3.Remove front grille and front panel</b>		
a	Remove the 2 screws connecting the front grille with front panel. Remove front grille.	 <p>front grille</p>
b	Remove the 5 screws connecting the front panel with the chassis and the motor support. Remove the front panel.	 <p>front panel</p>
<b>4. Remove right side panel</b>		
	Remove the 6 screws connecting the right side panel with the chassis, the valve support and the electric box. Remove the right side panel.	 <p>right side panel</p>

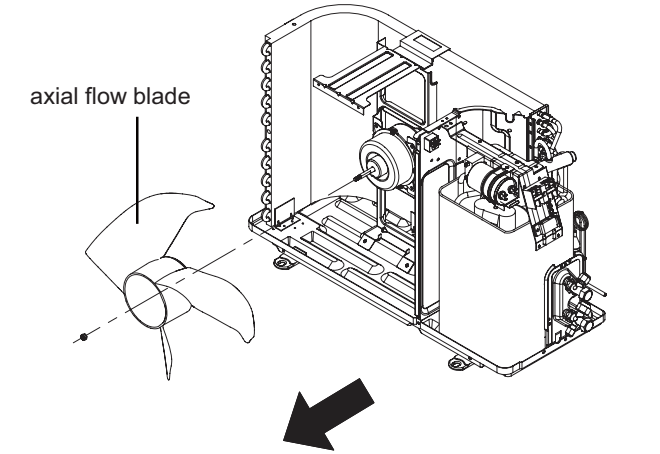
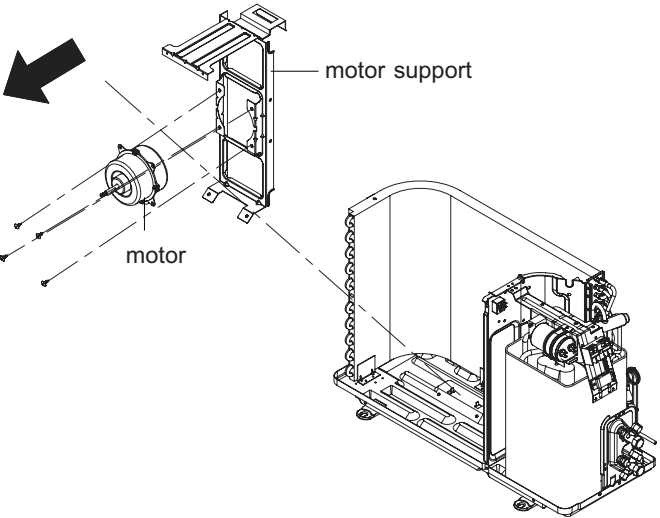
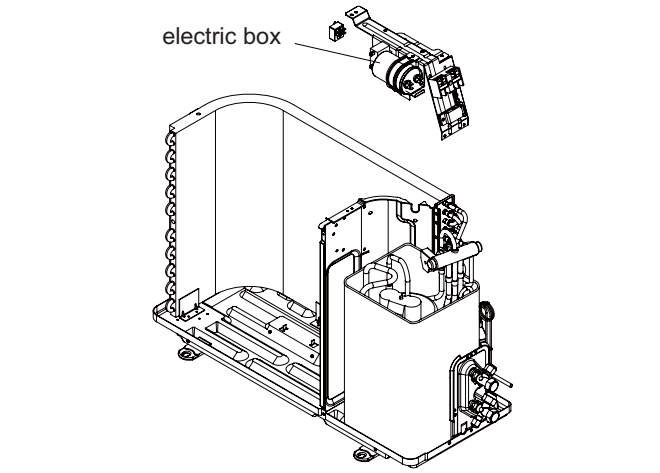
Step	Procedure	
<b>5. Remove axial flow blade and motor</b>		
a	Remove the nut on the blade. Remove the axial flow blade.	 <p>The diagram shows an isometric view of the motor assembly. A callout labeled 'axial flow blade' points to a separate drawing of the blade. A large black arrow points from the blade callout to the next diagram, which shows the blade being removed from the motor support structure.</p>
b	Remove the tapping screws fixing the motor; disconnect the leading wire insert of the motor. Remove the motor. Remove the tapping screws fixing the motor support. Lift the motor support to remove it.	 <p>The diagram shows an isometric view of the motor assembly. A callout labeled 'motor support' points to a separate drawing of the support structure. A large black arrow points from the support callout to the next diagram, which shows the motor and support being removed from the main assembly. A callout labeled 'motor' points to the motor component.</p>
<b>6. Remove electric box</b>		
	Remove screws fixing the electric box subassembly. Loosen the wire bundle; unplug the wiring terminals and lift the electric box to remove it.	 <p>The diagram shows an isometric view of the motor assembly. A callout labeled 'electric box' points to a separate drawing of the electric box subassembly. A large black arrow points from the box callout to the main assembly, indicating the location of the box to be removed.</p>

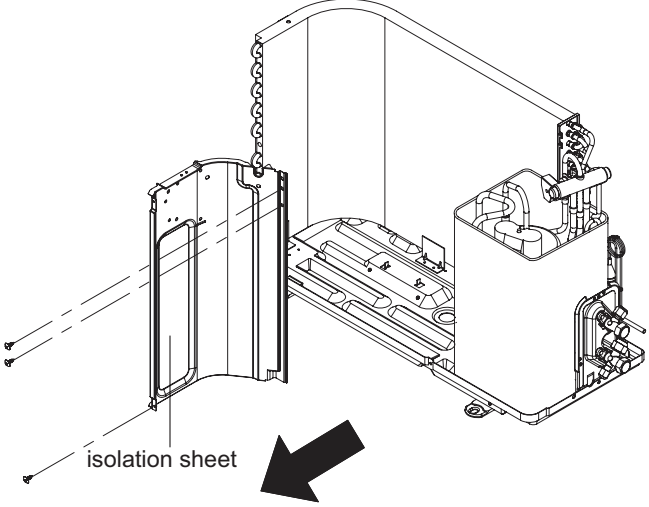
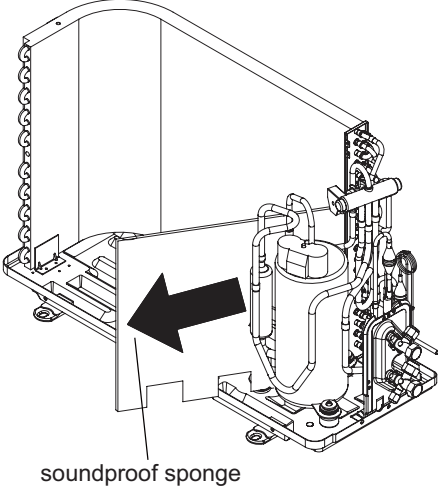
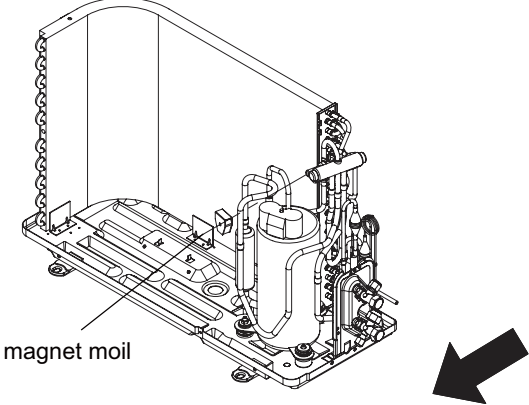
Step	Procedure
<b>7. Remove isolation sheet</b>	<p data-bbox="245 488 738 544">Remove the 3 screws fixing the isolation sheet. Remove the isolation sheet.</p>  <p data-bbox="900 748 1054 779">isolation sheet</p>
<b>8. Remove soundproof sponge</b>	<p data-bbox="245 1093 724 1149">Remove the soundproof sponge wrapping the compressor.</p>  <p data-bbox="943 1346 1142 1377">soundproof sponge</p>
<b>9. Remove magnet moil</b>	<p data-bbox="245 1653 687 1709">Remove the screw fixing the magnet moil. Remove the coil.</p>  <p data-bbox="847 1850 978 1881">magnet moil</p>

Step	Procedure
<b>10. Remove compressor</b>	
a	<p>Remove the 2 screws fixing the gas valve. Unsolder the welding joint connecting the gas valve and the air-return pipe. Remove the gas valve.            (NOTE: when unsoldering, wrap the gas valve with a wet cloth completely to avoid damage to the valve caused by high temperature.)            Remove the 2 screws fixing the liquid valve. Unsolder the welding joint connecting the liquid valve and the Y-type pipe. Remove the liquid valve.            (NOTE: Discharge the refrigerant completely before unsoldering.)</p>
b	<p>Unsolder welding joint connecting the capillary, the valve and the outlet pipe of condenser to remove the capillary. Do not block the capillary with welding slag during unsoldering. Unsolder the pipes connected to the compressor. Unsolder the welding joint connecting the 4-way valve to remove it.</p>
c	<p>Remove the 3 foot nuts on the compressor. Remove the compressor.</p>

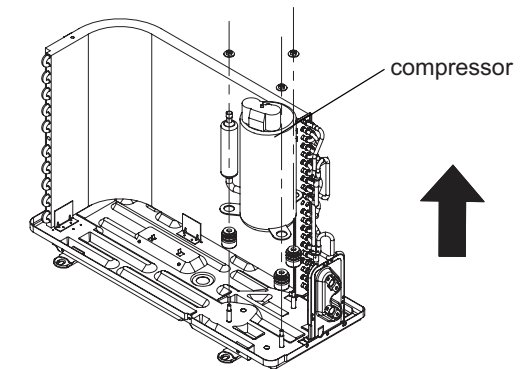
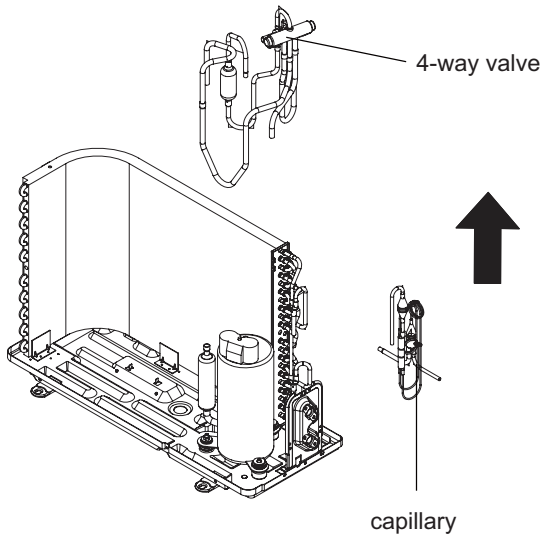
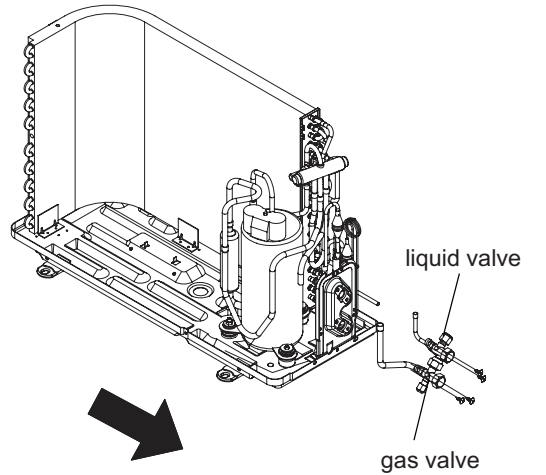

**⚠ Warning** Be sure to wait for a minimum of 10 minutes after turning off all power supplies before disassembly.

(2) GWH09NA-K3NNB1A/O GWH09NA-K3NNB1C/O GWH12NB-K3NNB1A/O GWH12NB-K3NNB1C/O

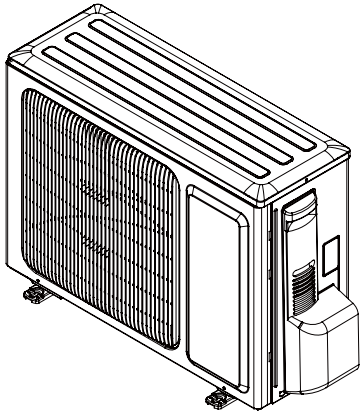
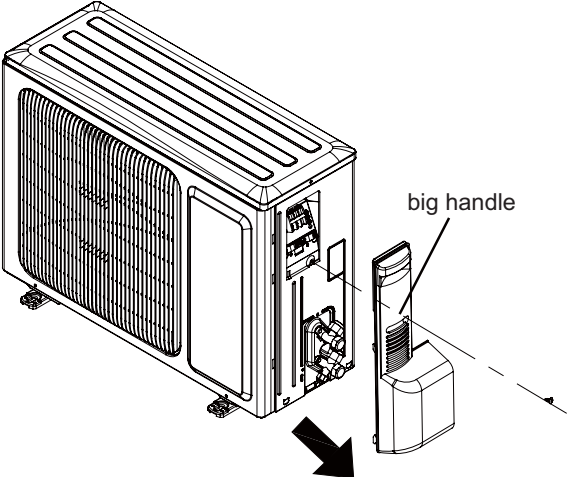
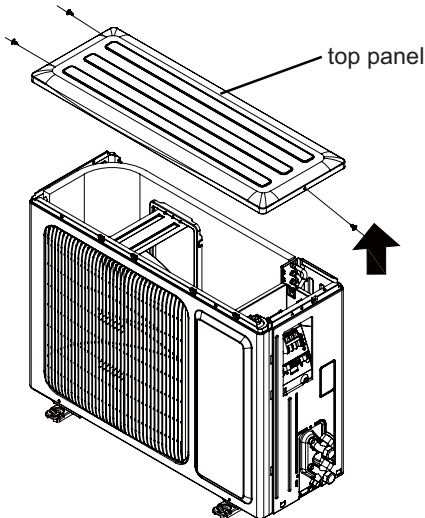
Step	Procedure	
1. Before disassembly		
2. Remove big handle	<p>Remove the connection screw fixing the big handle and then remove the handle.</p>	
3. Remove top panel	<p>Remove connection screws connecting the top panel with the front panel and the right side plate, and then remove the top panel.</p>	

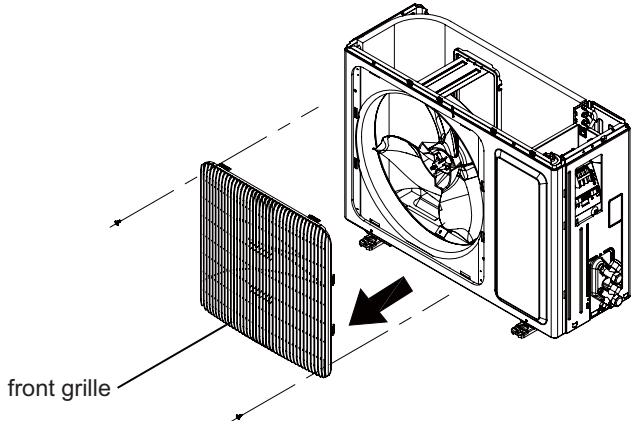
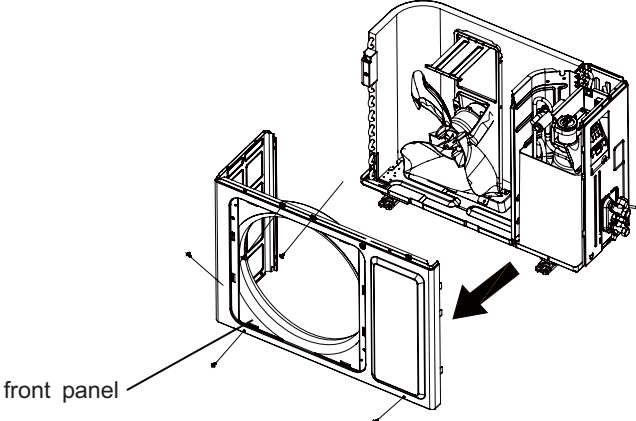
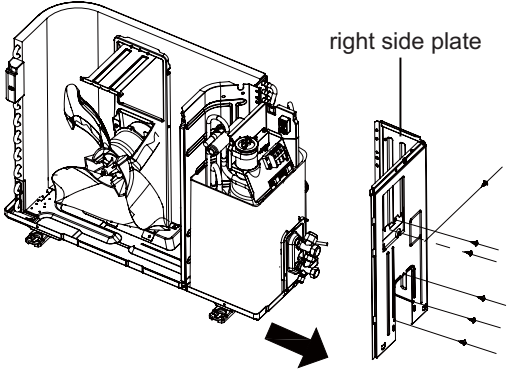
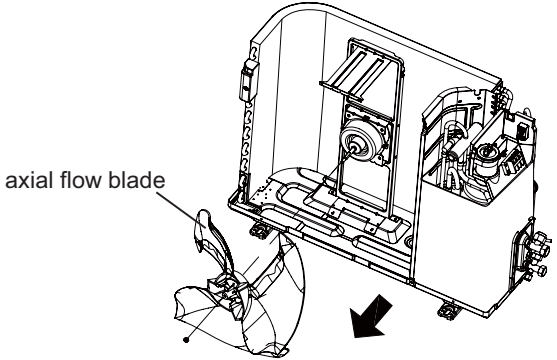
Step	Procedure
<p><b>4. Remove front grille</b></p>	<p>Remove connection screws between the front grille and the front panel. Then remove the front grille.</p>  <p>front grille</p>
<p><b>5. Remove front panel</b></p>	<p>Remove connection screws connecting the front panel with the chassis and the motor support, and then remove the front panel.</p>  <p>front panel</p>
<p><b>6. Remove right side plate</b></p>	<p>Remove connection screws connecting the right side plate with the chassis, the valve support and the electric box. Then remove the right side plate.</p>  <p>right side plate</p>
<p><b>7. Remove axial flow blade</b></p>	<p>Remove the nut on the blade and then remove the axial flow blade.</p>  <p>axial flow blade</p>

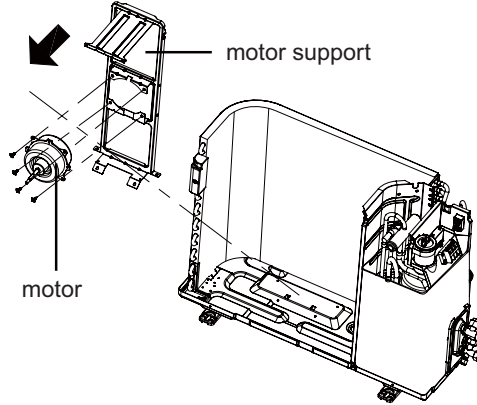
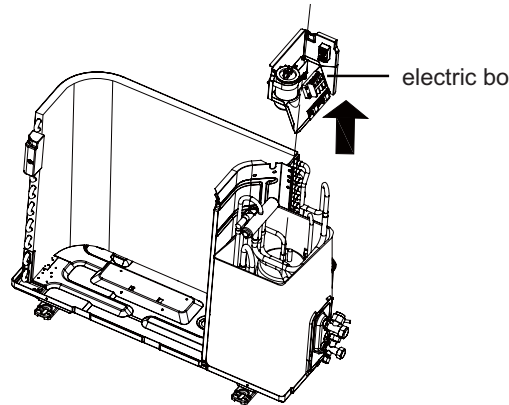
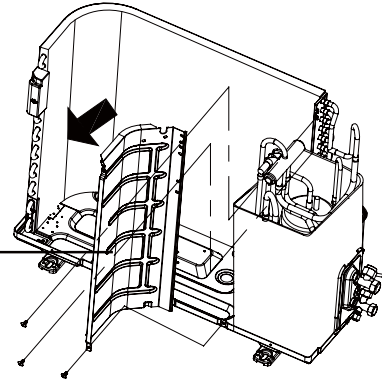
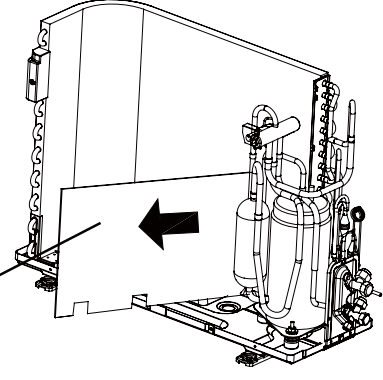
Step	Procedure	
<b>8. Remove motor and motor support</b>	Remove the 4 tapping screws fixing the motor and disconnect the leading wire insert of the motor. Then remove the motor. Remove the 2 tapping screws fixing the motor support and lift the motor support to remove it.	
<b>9. Remove electric box</b>	Remove screws fixing the electric box subassembly; loosen the wire bundle and unplug the wiring terminals. Then lift the electric box to remove it.	
<b>10. Remove isolation sheet</b>	Remove the 3 screws fixing the isolation sheet and then remove the isolation sheet.	
<b>11. Remove soundproof sponge</b>	Remove the soundproof sponge wrapping the compressor.	

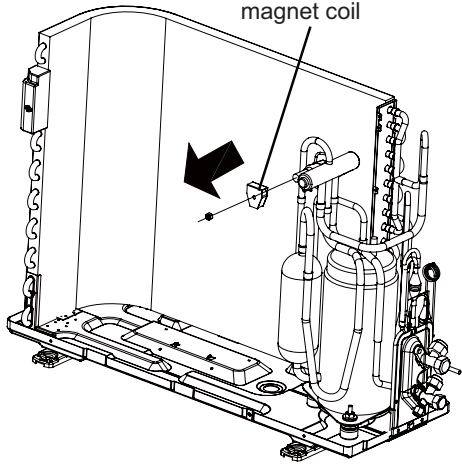
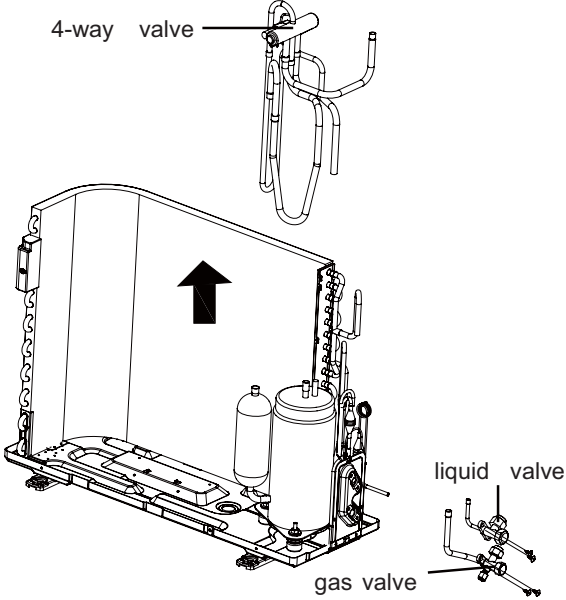
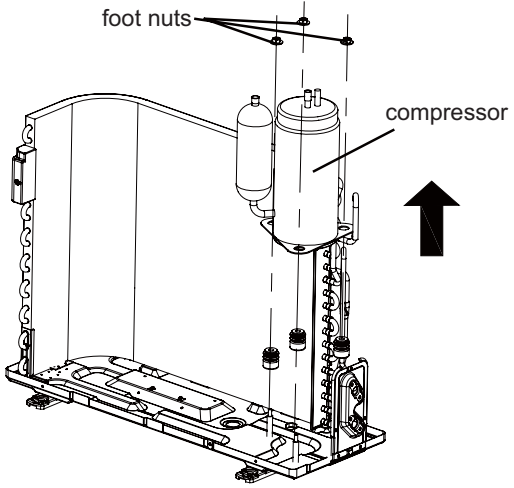
Step	Procedure	
<p><b>12. Remove magnet coil</b></p>	<p>Remove the screw fixing the magnet coil and then remove the coil.</p>	
<p><b>13. Remove valves and 4-way valve subassembly</b></p>	<p>Unsolder welding joint connecting the capillary, the valve and the outlet pipe of condenser to remove the capillary. Do not block the capillary with welding slag during unsoldering.                      Remove the 2 screws fixing the gas valve and unsolder the welding point between the gas valve and the air-return pipe to remove the gas valve.                      (NOTE: Discharge the refrigerant completely before unsoldering; when unsoldering, wrap the gas valve with a wet cloth completely to avoid damage to the valve caused by high temperature).                      Remove the 2 screws fixing the liquid valve and unsolder the welding joint connecting the liquid valve to the Y-type pipe to remove the liquid valve.                      Unsolder the welding joint connecting the 4-way valve, the compressor and the condenser to remove the 4-way valve.</p>	
<p><b>14. Remove compressor</b></p>	<p>Remove the foot nuts on the compressor and then remove the compressor.</p>	



JF00300988

**GREE ELECTRIC APPLIANCES, INC. OF ZHUHAI**

Add: West Jinji Rd, Qianshan, Zhuhai, Guangdong, China, 519070

Tel: (+86-756) 8522218 Fax: (+86-756) 8669426

E-mail: [gree@gree.com.cn](mailto:gree@gree.com.cn) [www.gree.com](http://www.gree.com)

For continuous improvement in the products, Gree reserves the right to modify the product specification and appearance in this manual without notice and without incurring any obligations.