



Service Manual

Models:GWH18PD-K3NNA1A(CA414000100)
GWH18PD-K3NNA1A(CA414000101)
GWH18PD-K3NNA1A(CA414000102)
GWH24PD-K3NNA1A(CA414000201)
GWH24PD-K3NNA1A(CA414000202)
(Refrigerant R410A)

Table of Contents

Summary and Features	1
1. Safety Precautions	2
2. Specifications	3
2.1 Unit Specifications.....	3
2.2 Capacity Variation Ratio According to Temperature	7
2.3 Operation Data	7
3. Construction Views	8
3.1 Indoor Unit.....	8
3.2 Outdoor Unit.....	8
4. Refrigerant System Diagram	10
5. Schematic Diagram	11
5.1 Electrical Data	11
5.2 Electrical Wiring.....	11
5.3 Printed Circuit Board	15
6. Function and Control	16
6.1 Remote Controller Description	16
6.3 Description of Each Control Operation.....	20
7. Installation Manual	24
7.1 Notices for Installation	24
7.2 Installation Drawing.....	26
7.3 Install Indoor Unit	27
7.4 Installation of Outdoor Unit.....	28
7.5 Check after Installation and Test Operation	29
7.6 Installation and Maintenance of Healthy Filter	30

8. Exploded Views and Parts List	31
8.1 Indoor Unit.....	31
8.2 Outdoor Unit.....	34
9. Troubleshooting	38
9.1 Precautions before Performing Inspection or Repair	38
9.2 Confirmation	38
9.3 Judgement by Flashing LED of Indoor/Outdoor Unit.....	38
9.4 How to Check Simply the Main Part.....	40
10. Removal Procedure	47
10.1 Removal Procedure of Indoor Unit.....	47
10.2 Removal Procedure of Outdoor Unit	55

Summary and Features

Indoor Unit

GWH18PD-K3NNA1A/I(CA414N00100)
GWH18PD-K3NNA1A/I(CA414N00101)
GWH24PD-K3NNA1A/I(CA414N00201)
GWH24PD-K3NNA1A/I(CA414N00200)

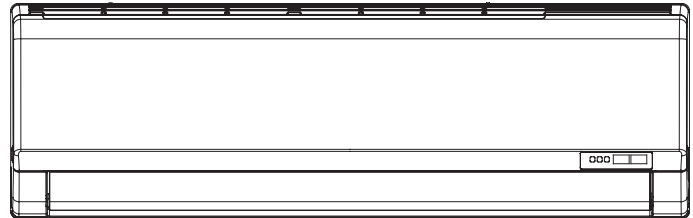

Outdoor Unit

GWH18PD-K3NNA1A/O

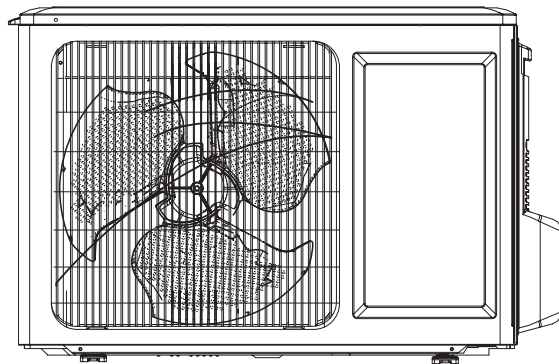

GWH24ND-K3NNB1A/O

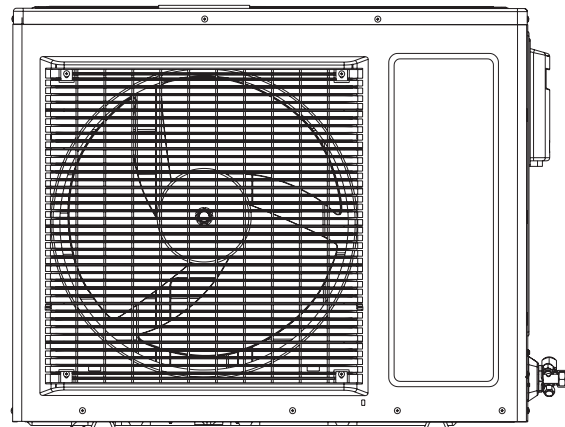

Remote Controller

YAM1F



1. Safety Precautions



Installing, starting up, and servicing air conditioner can be hazardous due to system pressure, electrical components, and equipment location, etc.

Only trained, qualified installers and service personnel are allowed to install, start-up, and service this equipment. Untrained personnel can perform basic maintenance functions such as cleaning coils. All other operations should be performed by trained service personnel.

When handling the equipment, observe precautions in the manual and on tags, stickers, and labels attached to the equipment. Follow all safety codes. Wear safety glasses and work gloves. Keep quenching cloth and fire extinguisher nearby when brazing.

Read the instructions thoroughly and follow all warnings or cautions in literature and attached to the unit. Consult local building codes and current editions of national as well as local electrical codes.

Recognize the following safety information:

-  **Warning** Incorrect handling could result in personal injury or death.
-  **Caution** Incorrect handling may result in minor injury, or damage to product or property.

- Make sure the outdoor unit is installed on a stable, level surface with no accumulation of snow, leaves, or trash beside.
- Make sure the ceiling/wall is strong enough to bear the weight of the unit.
- Make sure the noise of the outdoor unit does not disturb neighbors.
- Follow all the installation instructions to minimize the risk of damage from earthquakes, typhoons or strong winds.
- Avoid contact between refrigerant and fire as it generates poisonous gas.
- Apply specified refrigerant only. Never have it mixed with any other refrigerant. Never have air remain in the refrigerant line as it may lead to rupture and other hazards.
- Make sure no refrigerant gas is leaking out when installation is completed.
- Should there be refrigerant leakage, the density of refrigerant in the air shall in no way exceed its limited value, or it may lead to explosion.
- Keep your fingers and clothing away from any moving parts.
- Clear the site after installation. Make sure no foreign objects are left in the unit.
- Always ensure effective grounding for the unit.

Warning

All electric work must be performed by a licensed technician according to local regulations and the instructions given in this manual.

- Before installing, modifying, or servicing system, main electrical disconnect switch must be in the OFF position. There may be more than 1 disconnect switch. Lock out and tag switch with a suitable warning label.
- Never supply power to the unit unless all wiring and tubing are completed, reconnected and checked.
- This system adopts highly dangerous electrical voltage. Incorrect connection or inadequate grounding can cause personal injury or death. Stick to the wiring diagram and all the instructions when wiring.
- Have the unit adequately grounded in accordance with local electrical codes.
- Have all wiring connected tightly. Loose connection may lead to overheating and a possible fire hazard.

All installation or repair work shall be performed by your dealer or a specialized subcontractor as there is the risk of fire, electric shock, explosion or injury.

Caution

- Never install the unit in a place where a combustible gas might leak, or it may lead to fire or explosion.
- Make a proper provision against noise when the unit is installed at a telecommunication center or hospital.
- Provide an electric leak breaker when it is installed in a watery place.
- Never wash the unit with water.
- Handle unit transportation with care. The unit should not be carried by only one person if it is more than 20kg.
- Never touch the heat exchanger fins with bare hands.
- Never touch the compressor or refrigerant piping without wearing glove.
- Do not have the unit operate without air filter.
- Should any emergency occur, stop the unit and disconnect the power immediately.
- Properly insulate any tubing running inside the room to prevent the water from damaging the wall.

2. Specifications

2.1 Unit Specifications

Model			GWH18PD-K3NNA1A	GWH18PD-K3NNA1A
Product Code			CA414000100 /CA414000101	CA414000102
Power Supply	Rated Voltage	V ~	220-240	220-240
	Rated Frequency	Hz	50	50
	Phases		1	1
Power Supply Mode			Indoor	Indoor
Cooling Capacity		W	4700	4700
Heating Capacity		W	4900	4900
Cooling Power Input		W	1460	1460
Heating Power Input		W	1430	1430
Cooling Power Current		A	6.50	6.50
Heating Power Current		A	6.35	6.35
Rated Input		W	1980	1980
Rated Current		A	10	9.8
Air Flow Volume(SH/H/M/L/SL)		m ³ /h	850/780/650/500/-	850/780/650/500/-
Dehumidifying Volume		L/h	1.8	1.8
EER		W/W	3.22	3.22
COP		W/W	3.43	3.43
SEER		W/W	/	/
HSPF		W/W	/	/
Application Area		m ²	23-34	23-34
Indoor Unit	Model of indoor unit		GWH18PD-K3NNA1A/I	GWH18PD-K3NNA1A/I
	Fan Type		Cross-flow	Cross-flow
	Diameter Length(DXL)	mm	Φ98X710	Φ98X710
	Fan Motor Cooling Speed(SH/H/M/L/SL)	r/min	1350/1200/1000/800/-	1350/1200/1000/800/-
	Fan Motor Heating Speed(SH/H/M/L/SL)	r/min	1420/1250/1100/950/-	1420/1250/1100/950/-
	Output of Fan Motor	W	20	20
	Fan Motor RLA	A	0.31	0.31
	Fan Motor Capacitor	μF	1.5	1.5
	Input of Heater	W	/	/
	Evaporator Form		Aluminum Fin-copper Tube	Aluminum Fin-copper Tube
	Pipe Diameter	mm	Φ7	Φ7
	Row-fin Gap	mm	2-1.4	2-1.4
	Coil Length (LXDXW)	mm	715X25.4X304.8	715X25.4X304.8
	Swing Motor Model		MP28VB	MP28VB
	Output of Swing Motor	W	2	2
	Fuse	A	3.15	3.15
	Sound Pressure Level (SH/H/M/L/SL)	dB (A)	45/42/37/33/-	45/42/38/34/-
	Sound Power Level (SH/H/M/L/SL)	dB (A)	55/52/47/43/-	55/52/48/44/-
	Dimension (WXHXD)	mm	945X298X200	945X298X200
	Dimension of Carton Box (LXWXH)	mm	1010X380X285	1010X380X285
Dimension of Package(LXWXH)	mm	1013X383X300	1013X383X300	
Net Weight	kg	13	13	
Gross Weight	kg	17	17	

Outdoor Unit	Model of Outdoor Unit		GWH18PD-K3NNA1A/O	GWH18PD-K3NNA1A/O
	Compressor Manufacturer/Trademark		Shanghai Hitachi Electrical Appliances Co.,Ltd	ZHUHAI LANDA COMPRESSOR CO.,LTD.
	Compressor Model		ASL180SV-C7LU	QXA-C18B030
	Compressor Oil		HAF68D1	RB68EP
	Compressor Type		Rotary	Rotary
	L.R.A.	A	32	32
	Compressor RLA	A	6.8	7
	Compressor Power Input	W	1500	1520
	Overload Protector		UP3-83G	Internal
	Throttling Method		Capillary	Capillary
	Operation Temp	°C	16~30	16~30
	Ambient Temp (Cooling)	°C	18~43	18~43
	Ambient Temp (Heating)	°C	-7~24	-7~24
	Condenser Form		Aluminum Fin-copper Tube	Aluminum Fin-copper Tube
	Pipe Diameter	mm	Φ7	Φ7
	Rows-fin Gap	mm	2-1.6	2-1.6
	Coil Length (LXDXW)	mm	735X25.4X495	735X25.4X495
	Fan Motor Speed	rpm	770	850
	Output of Fan Motor	W	35	35
	Fan Motor RLA	A	0.3	0.37
	Fan Motor Capacitor	μF	2.5	2.5
	Air Flow Volume of Outdoor Unit	m ³ /h	1800	1800
	Fan Type		Axial-flow	Axial-flow
	Fan Diameter	mm	Φ394.5	Φ394.5
	Defrosting Method		Automatic Defrosting	Automatic Defrosting
	Climate Type		T1	T1
	Isolation		I	I
	Moisture Protection		IP24	IP24
	Permissible Excessive Operating Pressure for the Discharge Side	MPa	4.3	4.3
	Permissible Excessive Operating Pressure for the Suction Side	MPa	2.5	2.5
	Sound Pressure Level (H/M/L)	dB (A)	55/-/-	55/-/-
	Sound Power Level (H/M/L)	dB (A)	65/-/-	65/-/-
	Dimension (WXHXD)	mm	848X540X320	848X540X320
Dimension of Carton Box (LXWXH)	mm	878X360X580	878X360X580	
Dimension of Package(LXWXH)	mm	881X363X595	881X363X595	
Net Weight	kg	40	40	
Gross Weight	kg	44	44	
Refrigerant		R410A	R410A	
Refrigerant Charge	kg	1.15	1.15	
Connection Pipe	Length	m	4	5
	Gas Additional Charge	g/m	20	30
	Outer Diameter Liquid Pipe	mm	Φ6	Φ6
	Outer Diameter Gas Pipe	mm	Φ12	Φ12
	Max Distance Height	m	10	10
	Max Distance Length	m	25	25

The above data is subject to change without notice. Please refer to the nameplate of the unit.

Specifications

Model			GWH24PD-K3NNA1A	GWH24PD-K3NNA1A
Product Code			CA414000201	CA414000202
Power Supply	Rated Voltage	V ~	220-240	220-240
	Rated Frequency	Hz	50	50
	Phases		1	1
Power Supply Mode			Indoor	Indoor
Cooling Capacity		W	6155	6155
Heating Capacity		W	6500	6500
Cooling Power Input		W	1900	1900
Heating Power Input		W	1900	1900
Cooling Power Current		A	8.5	8.5
Heating Power Current		A	8.8	8.8
Rated Input		W	2700	2700
Rated Current		A	15.7	15.7
Air Flow Volume(SH/H/M/L/SL)		m ³ /h	850/780/650/500/-	850/780/650/500/-
Dehumidifying Volume		L/h	1.8	1.8
EER		W/W	3.24	3.24
COP		W/W	3.42	3.42
SEER		W/W	/	/
HSPF		W/W	/	/
Application Area		m ²	23-34	23-34
Indoor Unit	Model of indoor unit		GWH24PD-K3NNA1A/I	GWH24PD-K3NNA1A/I
	Fan Type		Cross-flow	Cross-flow
	Diameter Length(DXL)	mm	Φ98X710	Φ98X710
	Fan Motor Cooling Speed(SH/H/M/L/SL)	r/min	1350/1200/1000/800/-	1350/1200/1000/800/-
	Fan Motor Heating Speed(SH/H/M/L/SL)	r/min	1420/1250/1100/950/-	1420/1250/1100/950/-
	Output of Fan Motor	W	20	20
	Fan Motor RLA	A	0.31	0.31
	Fan Motor Capacitor	μF	1.5	1.5
	Input of Heater	W	/	/
	Evaporator Form		Aluminum Fin-copper Tube	Aluminum Fin-copper Tube
	Pipe Diameter	mm	Φ7	Φ7
	Row-fin Gap	mm	2-1.4	2-1.4
	Coil Length (LXD _X W)	mm	715X25.4X304.8	715X25.4X304.8
	Swing Motor Model		MP28VB	MP28VB
	Output of Swing Motor	W	2	2
	Fuse	A	3.15	3.15
	Sound Pressure Level (SH/H/M/L/SL)	dB (A)	45/42/37/33/-	45/42/37/33/-
	Sound Power Level (SH/H/M/L/SL)	dB (A)	55/52/47/43/-	55/52/47/43/-
	Dimension (WXHXD)	mm	945X298X200	945X298X200
	Dimension of Carton Box (LXWXH)	mm	1010X380X285	1010X380X285
Dimension of Package(LXWXH)	mm	1013X383X300	1013X383X300	
Net Weight	kg	13	13	
Gross Weight	kg	17	17	

Outdoor Unit	Model of Outdoor Unit		GWH24ND-K3NNB1A/O	
	Compressor Manufacturer/Trademark		Shanghai Hitachi Electrical Appliances Co.,Ltd/Highly	
	Compressor Model		ASH232SV-C8LU	
	Compressor Oil		HAF68D1 or equivalent	
	Compressor Type		Rotary	
	L.R.A.	A		40
	Compressor RLA	A		8.8
	Compressor Power Input	W		1900
	Overload Protector			Internal
	Throttling Method			Capillary
	Operation Temp	°C		18~30
	Ambient Temp (Cooling)	°C		18~43
	Ambient Temp (Heating)	°C		-7~24
	Condenser Form			Aluminum Fin-copper Tube
	Pipe Diameter	mm		Φ7
	Rows-fin Gap	mm		2-1.4
	Coil Length (LXDXW)	mm		865X38.1X660
	Fan Motor Speed	rpm		780
	Output of Fan Motor	W		68
	Fan Motor RLA	A		0.75
	Fan Motor Capacitor	μF		3
	Air Flow Volume of Outdoor Unit	m ³ /h		2800
	Fan Type			Axial-flow
	Fan Diameter	mm		Φ460
	Defrosting Method			Automatic Defrosting
	Climate Type			T1
	Isolation			I
	Moisture Protection			IP24
	Permissible Excessive Operating Pressure for the Discharge Side	MPa		4.3
	Permissible Excessive Operating Pressure for the Suction Side	MPa		2.5
	Sound Pressure Level (H/M/L)	dB (A)		56/-/-
	Sound Power Level (H/M/L)	dB (A)		66/-/-
	Dimension (WXHXD)	mm		913X378X680
Dimension of Carton Box (LXWXH)	mm		997X431X740	
Dimension of Package(LXWXH)	mm		1000X434X755	
Net Weight	kg		46	
Gross Weight	kg		50	
Refrigerant			R410A	
Refrigerant Charge	kg		1.45	
Connection Pipe	Length	m	4	
	Gas Additional Charge	g/m	20	
	Outer Diameter Liquid Pipe	mm	Φ6	
	Outer Diameter Gas Pipe	mm	Φ12	
	Max Distance Height	m	10	
	Max Distance Length	m	25	

The above data is subject to change without notice. Please refer to the nameplate of the unit.

2.2 Capacity Variation Ratio According to Temperature

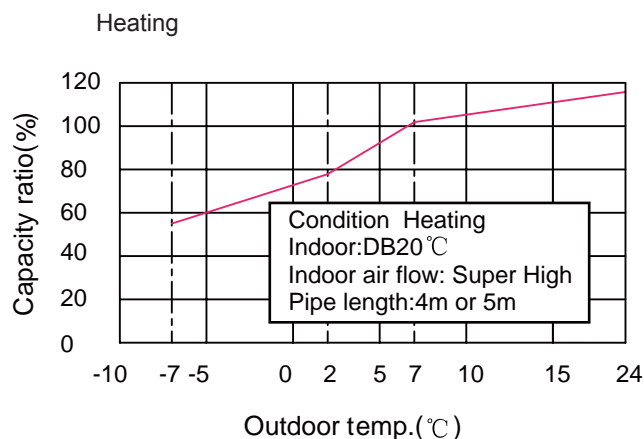
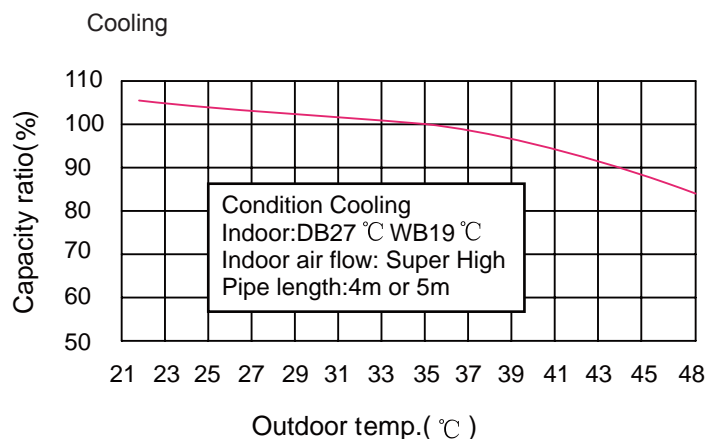

2.3 Operation Data

Cooling

Temperature condition (°C)		Model name	Standard pressure P (MPa)	Heat exchanger pipe temp.		Indoor fan mode	Outdoor fan mode
Indoor	Outdoor			T1 (°C)	T2 (°C)		
27/19	35/24	18K	0.8~0.9	in:8~11 out:11~12	in:75~85 out:37~43	Super High	High
		24K	0.8~1.0	in:8~11 out:11~14	in:75~85 out:36~43		

Heating

Temperature condition (°C)		Model name	Standard pressure P (MPa)	Heat exchanger pipe temp.		Indoor fan mode	Outdoor fan mode
Indoor	Outdoor			T1 (°C)	T2 (°C)		
20/-	7/6	18K	2.7~2.9	in:75~85 out:37~43	in:1~3 out:3~4	Super High	High
		24K	2.6~3.0	in:75~85 out:36~43	in:1~3 out:3~4		

NOTES :

- (1) T1: Inlet and outlet pipe temperature of evaporator
T2: Inlet and outlet pipe temperature of condenser
P: Pressure of air pipe connecting indoor and outdoor units(on the side of gas pipe)
- (2) Measure surface temperature of heat exchanger pipe around center of heat exchanger path U bent.(The rmistor the mometer)
- (3) Connecting piping condition : 4m or 5m

3. Construction Views

3.1 Indoor Unit

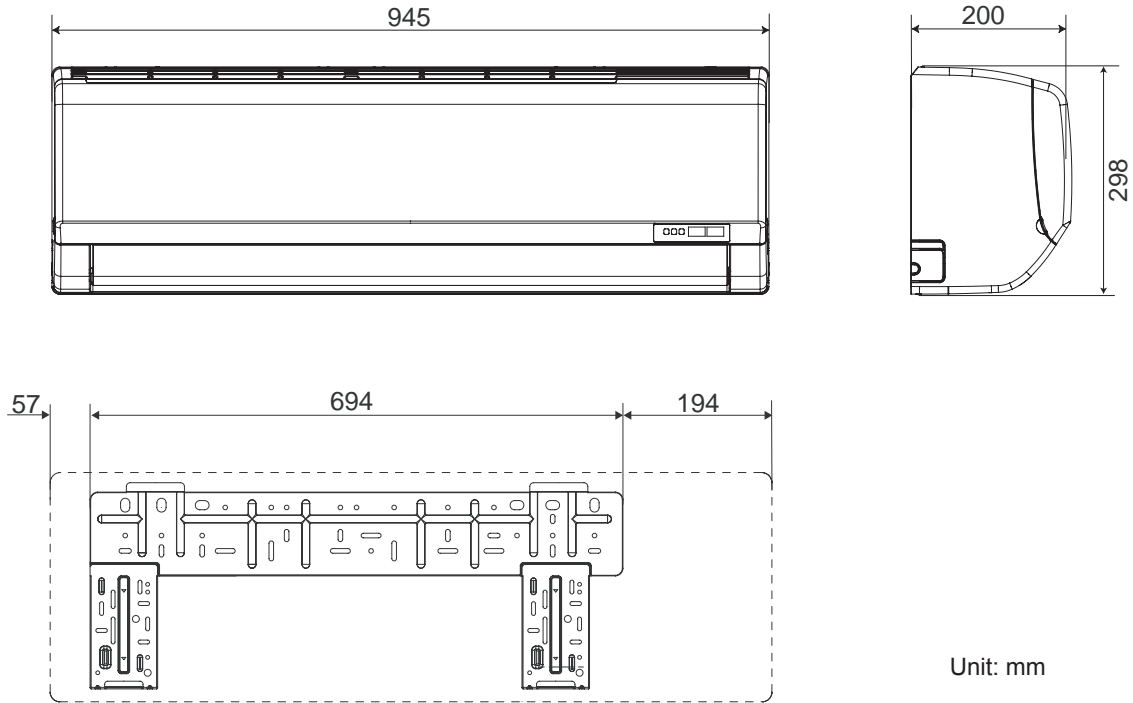

Unit: mm

3.2 Outdoor Unit

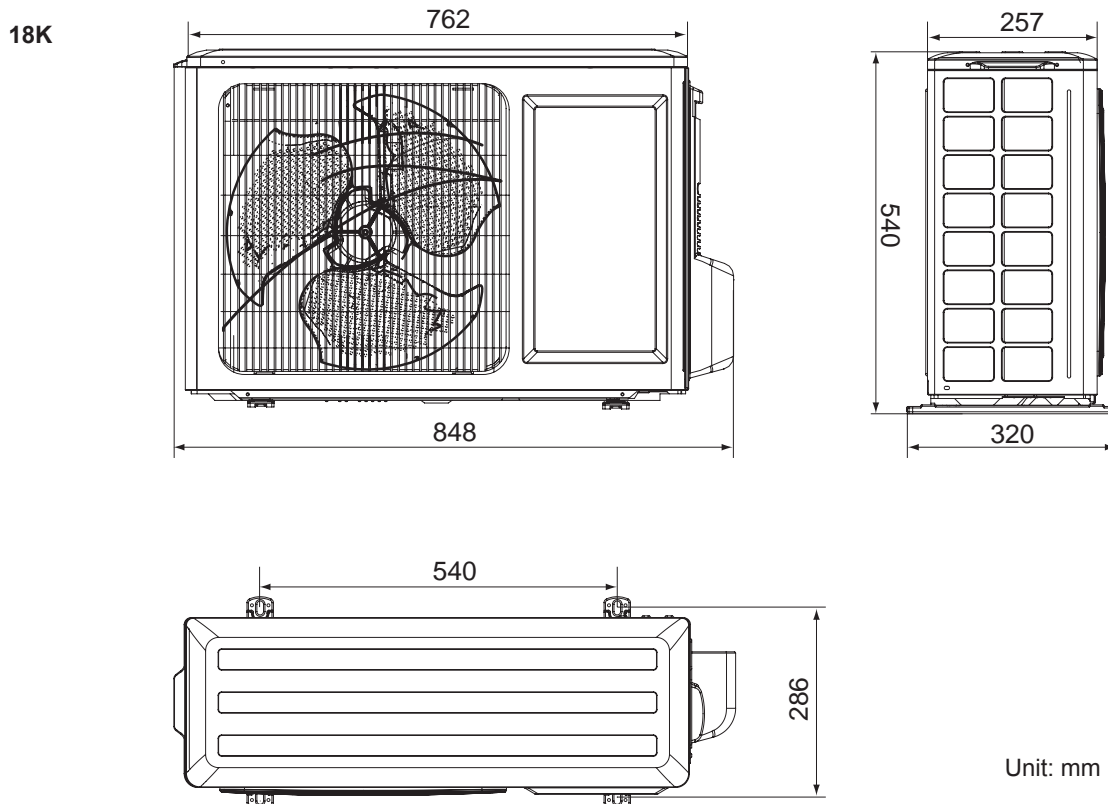

Unit: mm

24K

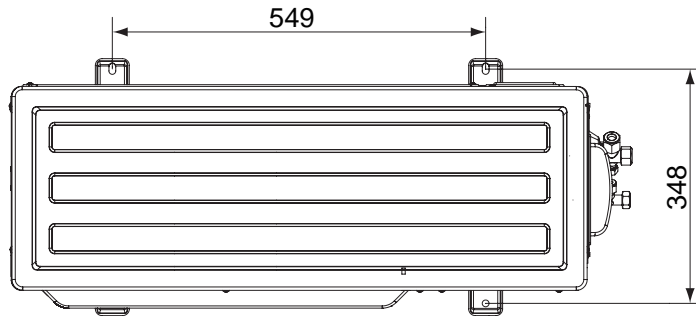
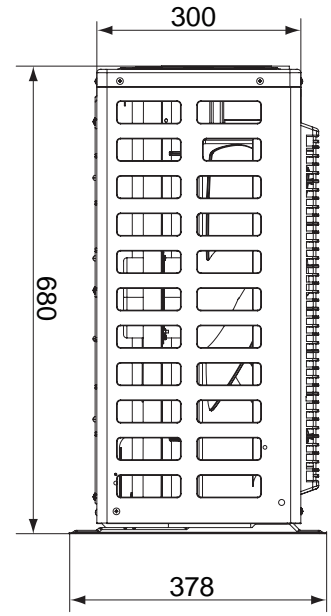
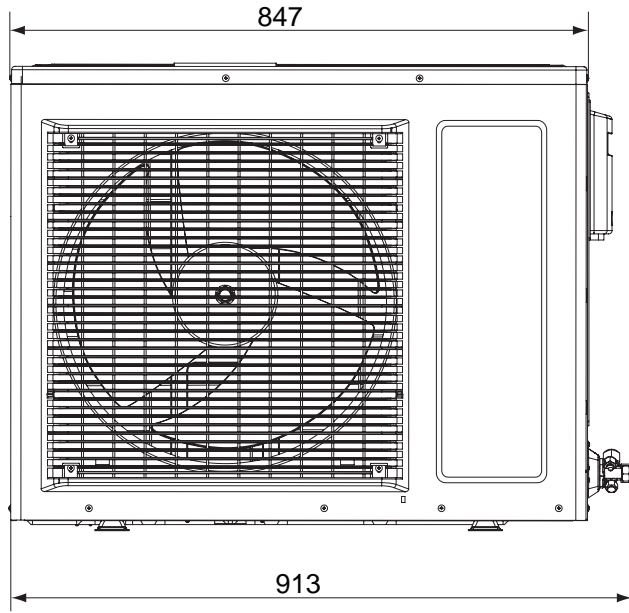

Unit: mm

4. Refrigerant System Diagram

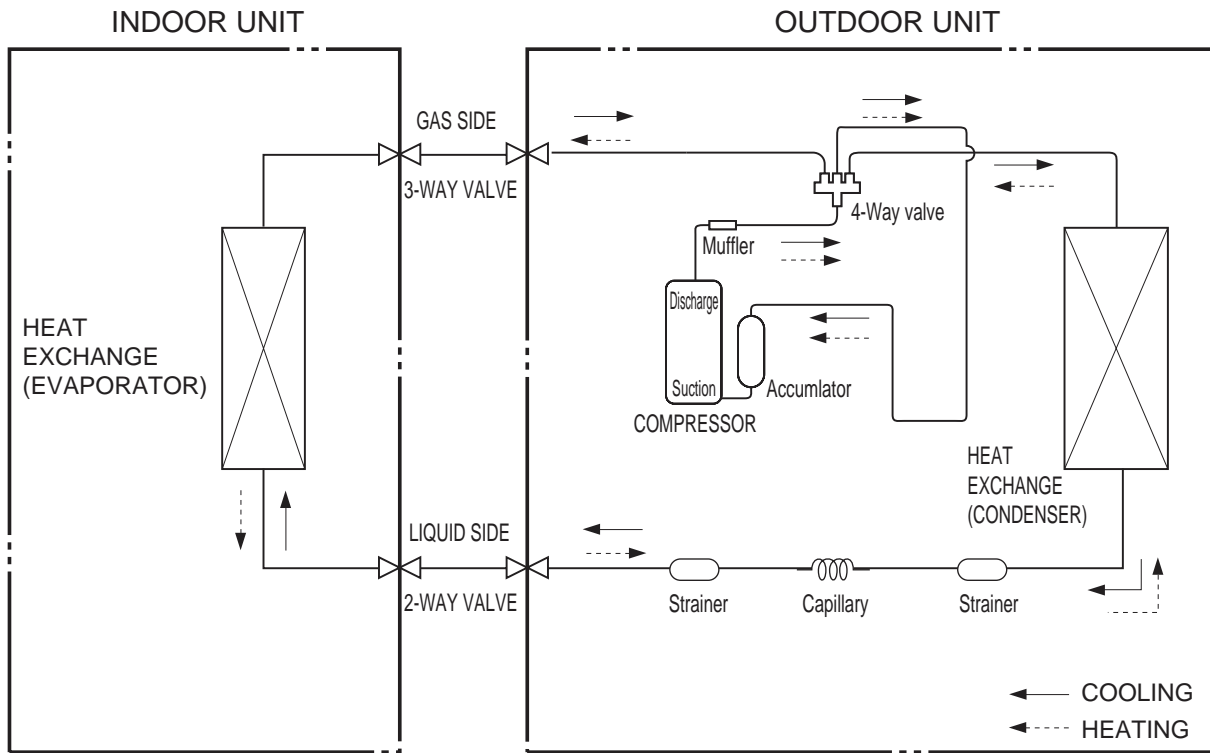

Refrigerant pipe diameter
 Liquid : 1/4" (6 mm)
 Gas : 1/2" (12mm)

5. Schematic Diagram

5.1 Electrical Data

Meaning of marks

Symbol	Color symbol	Symbol	Color symbol	Symbol	Parts name
WH	WHITE	GN	GREEN	SAT	OVERLOAD
YE	YELLOW	BN	BROWN	COMP	COMPRESSOR
RD	RED	BU	BLUE		PROTECTIVE EARTH
YEGN	YELLOW GREEN	BK	BLACK	/	/
VT	VIOLET	OG	ORANGE	/	/

5.2 Electrical Wiring

- Indoor Unit

GWH18PD-K3NNA1A/I(CA414N00100)

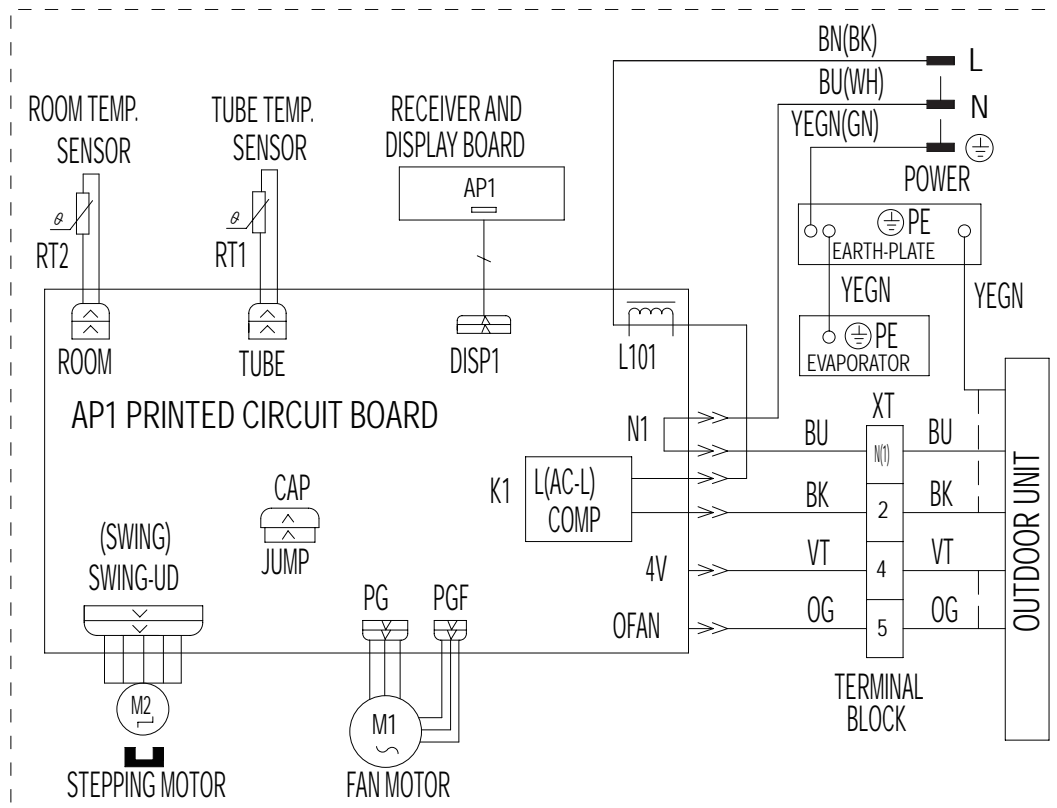

GWH18PD-K3NNA1A/I(CA414N00101)

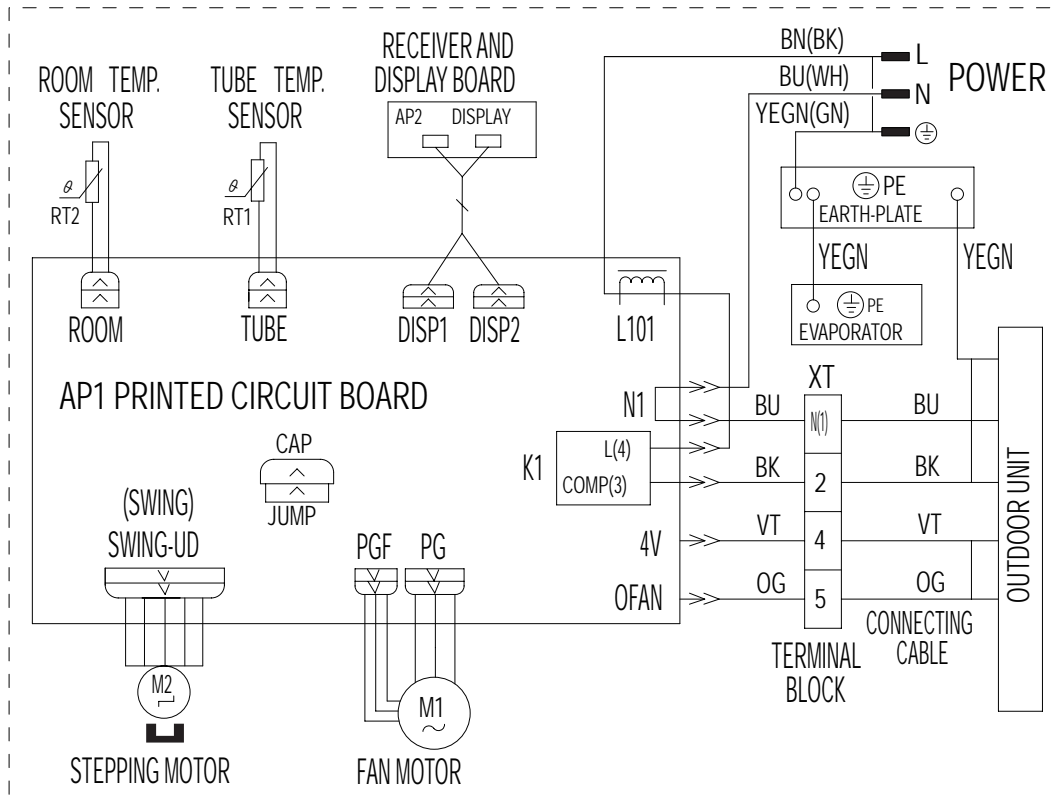

GWH24PD-K3NNA1A/I(CA414N00201)

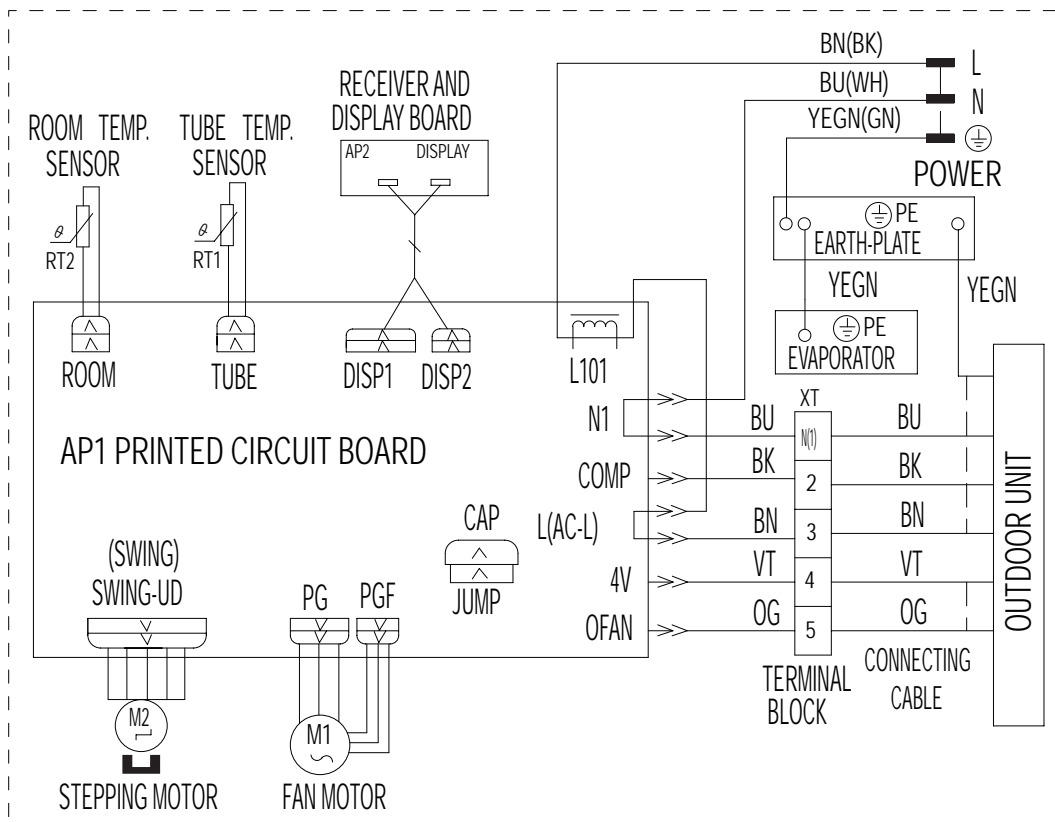

GWH24PD-K3NNA1A/I(CA414N00200)

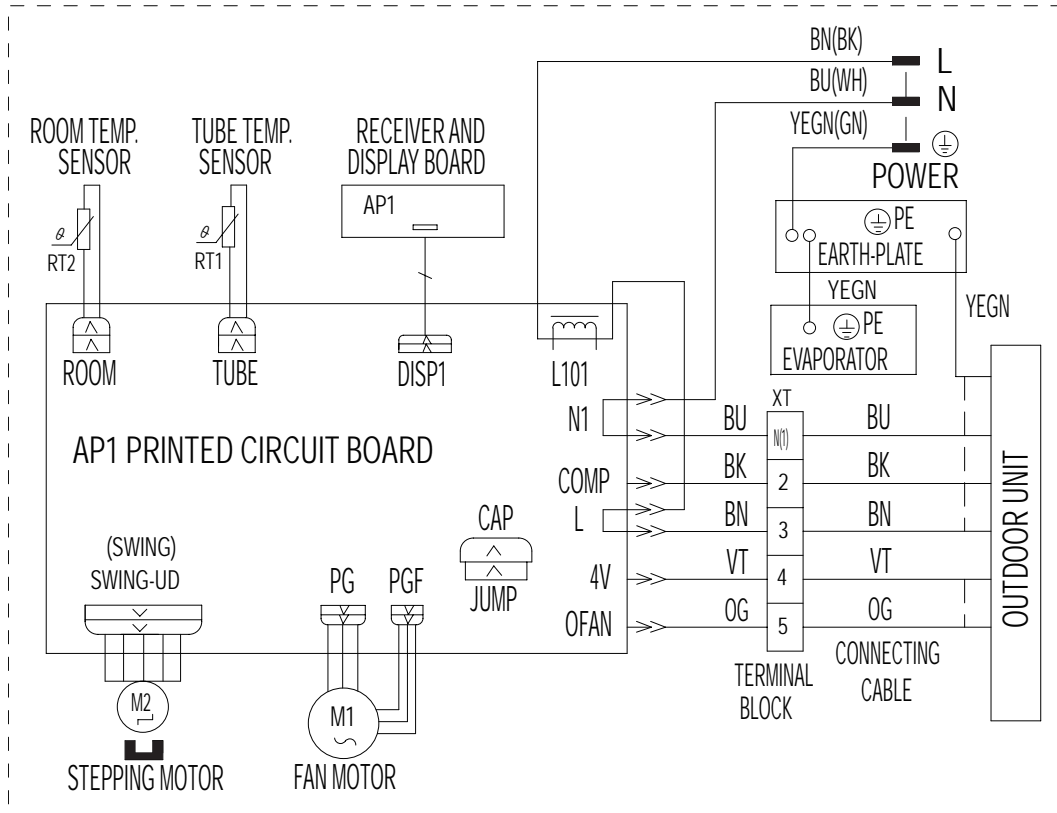

• Outdoor Unit

GWH18PD-K3NNA1A/O

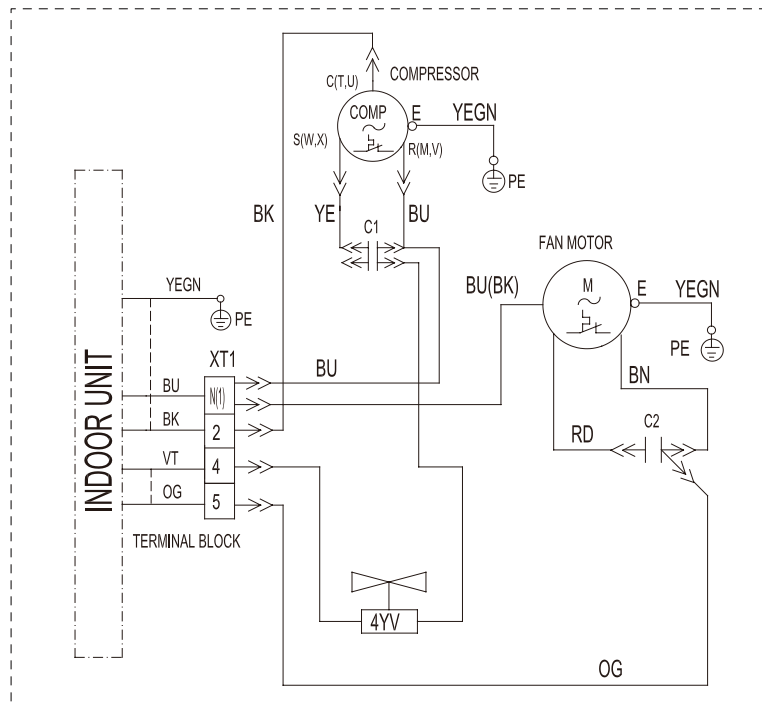

GWH24ND-K3NNB1A/O

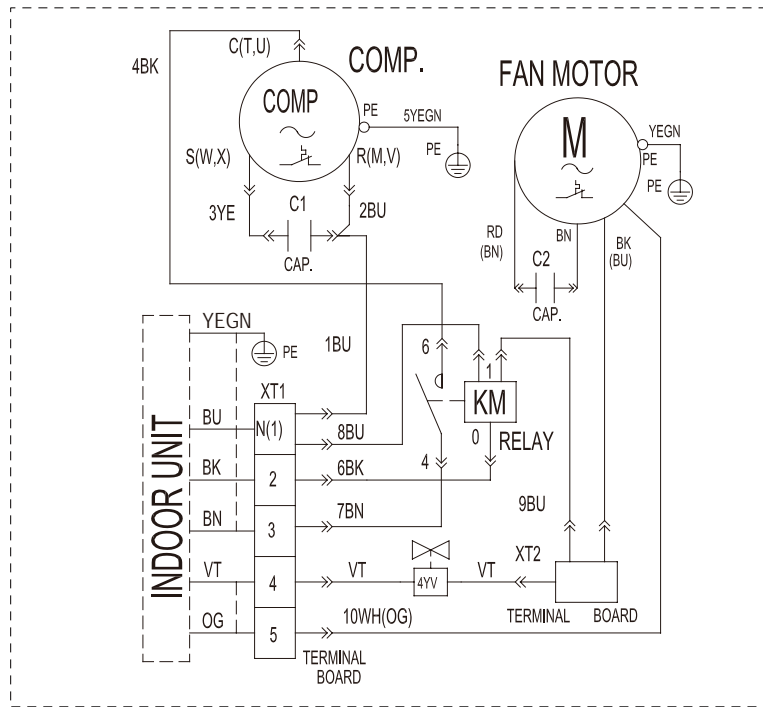

These circuit diagrams are subject to change without notice, please refer to the one supplied with the unit.

5.3 Printed Circuit Board

●TOP VIEW

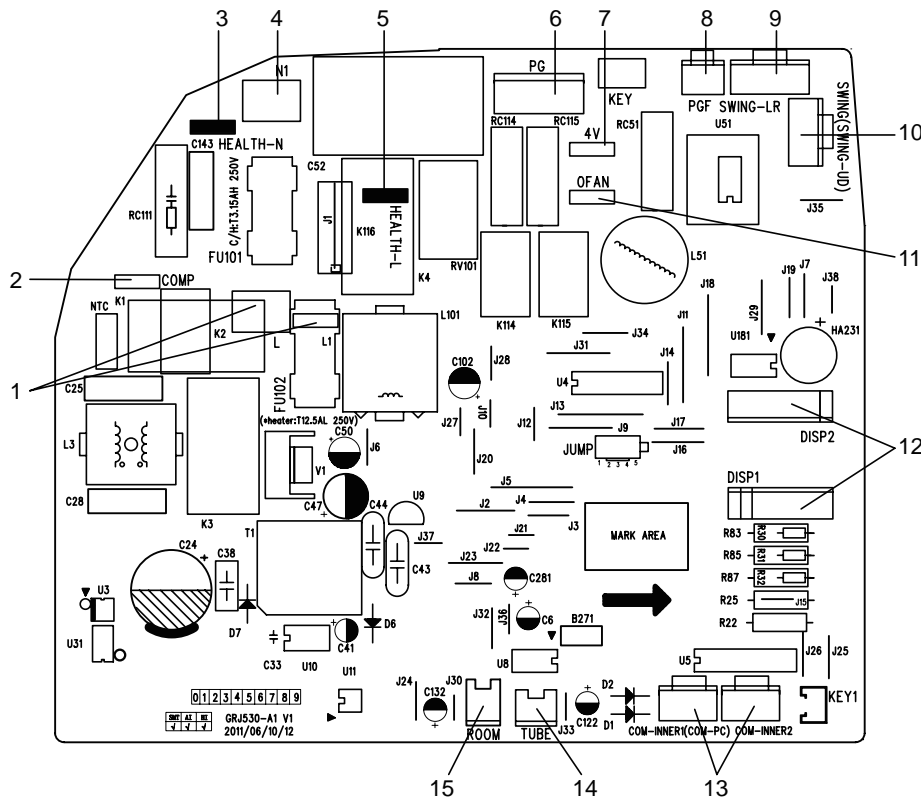

1	Interface of live wire
2	Interface of compressor
3	Interface of neutral wire for health function
4	Interface of neutral wire
5	Interface of live wire for health function
6	Control terminal of PG motor
7	Interface of 4-way valve
8	Feedback interface of PG motor
9	Left&right swing
10	Up&down swing
11	Interface of outdoor fan
12	Display interface
13	Interface of remote control motor
14	Interface of indoor tube temperature sensor
15	Interface of indoor ambient temperature sensor

●BOTTOM VIEW

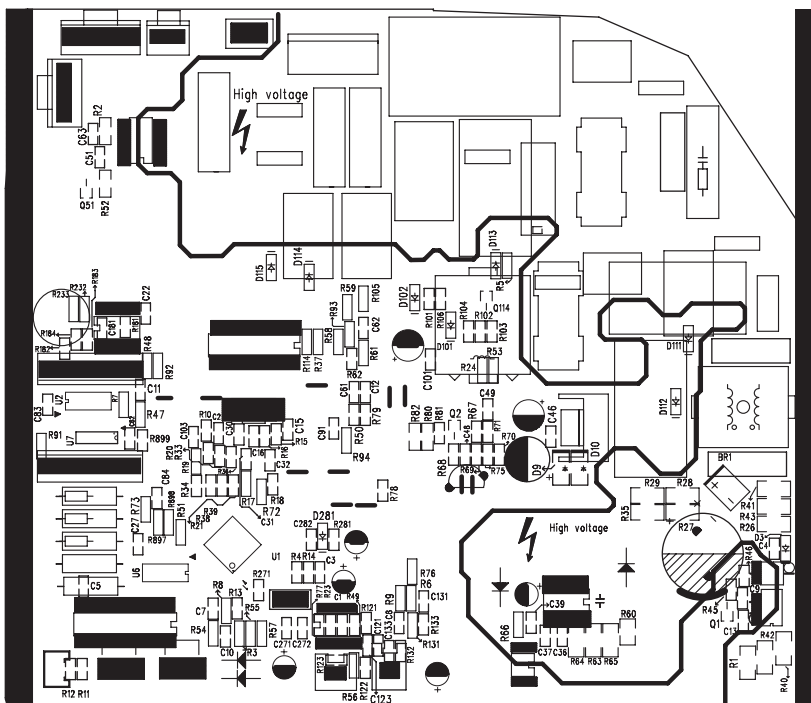

6. Function and Control

6.1 Remote Controller Description

Names and Functions of Wireless Remote Control

Note: Be sure that there are no obstructions between receiver and remote controller ;Don't drop or throw the remote control; Don't let any liquid in the remote control and put the remote control directly under the sunlight or any place where is very hot.

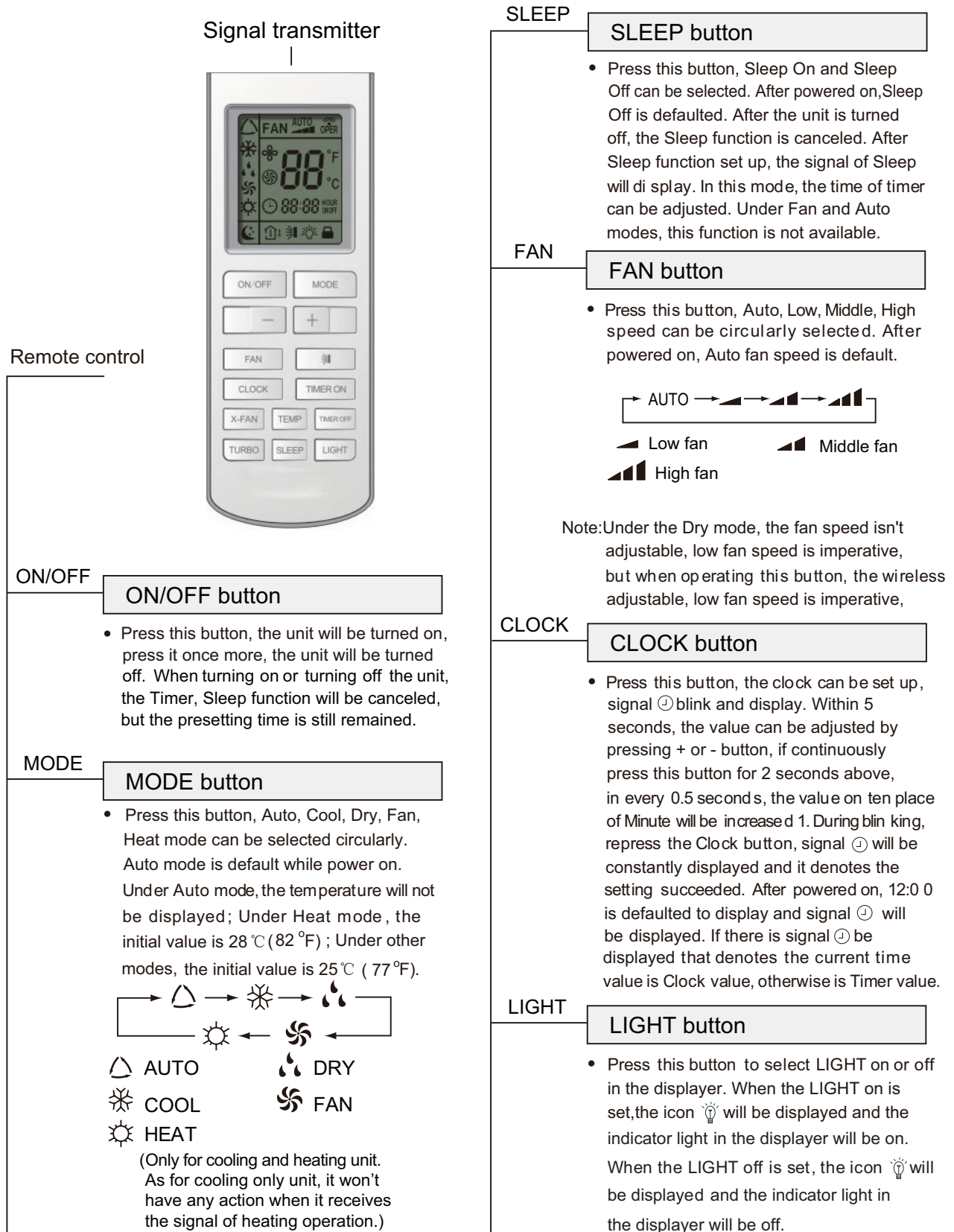

Notice: This is a general use remote controller, it could be used for the air conditioners with multifunction; For some function, which the model doesn't have, if press the corresponding button on the remote controller that the unit will keep the original running status.

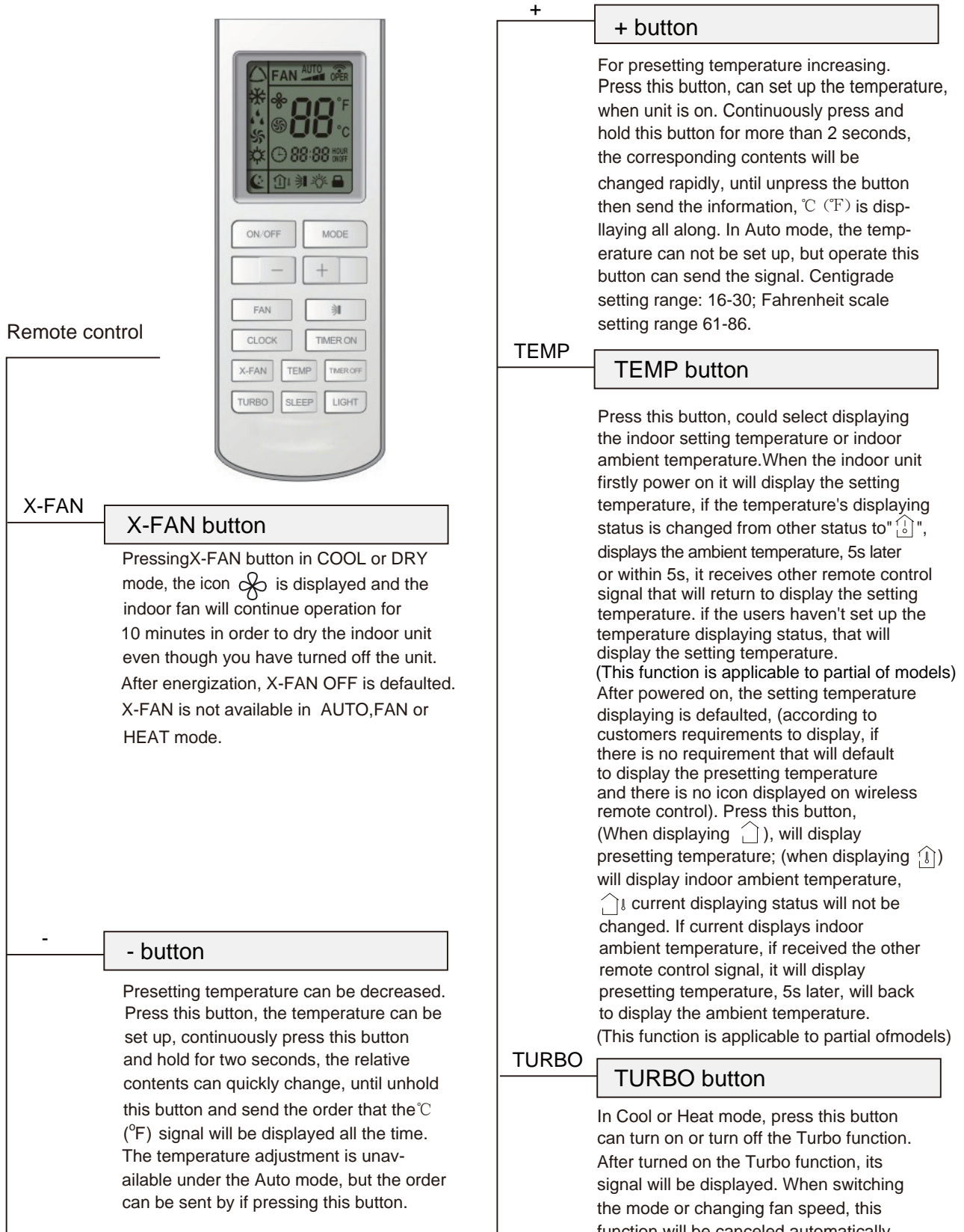

Notice: This is a general use remote controller, it could be used for the air conditioners with multifunction; For some function, which the model doesn't have, if press the corresponding button on the remote controller that the unit will keep the original running status.



Remote control

TIMER ON

TIMER ON BUTTON

Timer On setting: Signal "ON" will blink and display, signal ⊕ will conceal, the numerical section will become the timer on setting status. During 5 seconds blink, by pressing + or - button to adjust the time value of numerical section, every press of that button, the value will be increased or decreased 1 minute. Hold pressing + or - button, 2 seconds later, it quickly change, the way of change is: During the initial 2.5 seconds, ten numbers change in the one place of minute, then the one place is constant, ten numbers change in the tens place of minute at 2.5 seconds speed and carry. During 5s blink, press the Timer button, the timer setting succeeds. The Timer On has been set up, repress the timer On button, the Timer On will be canceled. Before setting the Timer, please adjust the Clock to the current actual time.

TIMER OFF

TIMER OFF BUTTON

Once press this key to enter into TIMER OFF setup, in which case the TIMER OFF icon will blink. The method of setting is the same as for TIMER ON.

SWING UP AND DOWN BUTTON

Press this button, to set up swing angle, which circularly changes as below:

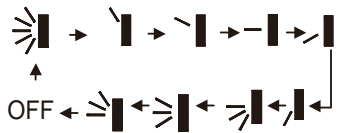

OFF ← → → → →

This is an universal use remote controller. If remote controller sends the following three kinds of status that the swing status of main unit will be:



When the guide louver start to swing up and down, if turn off the Swing, the air guide louver will stop at current position.

 which indicates the guide louver swings up and down between that all five positions.

Guide for Operation - General Operation

1. After powered on, press ON/OFF button, the unit will start to run. (Note: When it is powered on, the guide louver of main unit will close automatically.)
2. Press MODE button, select desired running mode.
3. Pressing + or - button, to set the desired temperature. (It is unnecessary to set the temp. at AUTO mode.)
4. Pressing FAN button, set fan speed, can select AUTO FAN, LOW, MID and HIGH.
5. Pressing  button, to select the swing.

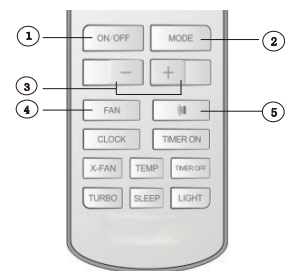

Guide for Operation - Optional Operation

1. Press SLEEP button, to set sleep.
2. Press TIMER ON and TIMER OFF button, can set the scheduled timer on
3. Press LIGHT button, to control the on and off of the displaying part of the unit (This function may be not available for some units).
4. Press TURBO button, can realize the ON and OFF of TURBO function.

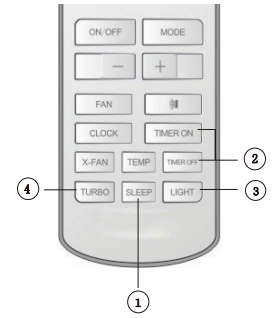

Introduction for Special Function

★ About X-FAN function

This function indicates that moisture on evaporator of indoor unit will be blown after the unit is stopped to avoid mould.

1. Having set X-FAN function on: After turning off the unit by pressing ON/OFF button indoor fan will continue running for about 10 min. at low speed. In this period, press X-FAN button to stop indoor fan directly.
2. Having set X-FAN function off: After turning off the unit by pressing ON/OFF button, the complete unit will be off directly.

★ About AUTO RUN

When AUTO RUN mode is selected, the setting temperature will not be displayed on the LCD, the unit will be in accordance with the room temp. automatically to select the suitable running method and to make ambient comfortable.

★ About turbo function

If start this function, the unit will run at super-high fan speed to cool or heat quickly so that the ambient temp. approaches the preset temp. as soon as possible.

★ About Blow over heat (This function is applicable to partial of models)

When the unit is running in Heat mode or Auto Heat mode, compressor and indoor fan is running, to turn the unit off, the compressor, outdoor fan will stop running. The upper and lower guide board rotate to horizontal position, then the indoor fan will run at low fan speed, 10s later, the unit will turn off.

★ About new function of defrosting

Under switch-off state, hold MODE key for 2 seconds to enter or exit defrost H1 function. After being energized, the defrost H1 function is defaulted off. When entering defrost H1 function, the double-8 nixie tube will display H1 under switch-off state. When adjusting to heat mode, the double-8 nixie tube will display in flash for 5 seconds at a frequency of 1 count / sec. After the flash is ended, the remote controller will display the preset heating temperature. Within these 5 seconds, press of +, - or TIMER key will cancel the display H1, while the double-8 nixie tube will display the preset temperature. To switch the display of temperature between Celsius and Fahrenheit after entering defrost H1 function, the temperature value to be switched will be displayed firstly before display of H1 after 5 seconds.

Replacement of Batteries

1. Remove the battery cover plate from the rear of the remote controller.
2. Take out the used batteries.
3. Insert two new AAA1.5V dry batteries, and pay attention to the polarity.
4. Reinstall the battery cover plate.

Notes:

- When replacing the batteries, do not use old or different types of batteries, otherwise, it may cause malfunction.
- If the remote controller will not be used for a long time, please remove batteries to prevent batteries from leaking.
- The operation should be performed in its receiving range.
- It should be kept 1m away from the TV set or stereo sound sets.
- If the remote controller does not operate normally, please take the batteries out and reinsert them after 30 seconds. If it still can't operate properly, replace the batteries.

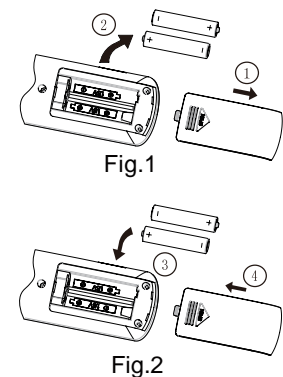

6.3 Description of Each Control Operation

1 Temperature Parameters

- ◆ Indoor preset temperature (T_{preset})
- ◆ Indoor ambient temperature ($T_{\text{amb.}}$)

2 Basic functions (The temperature in this manual is expressed by Centigrade. If Fahrenheit is used, the switchover between them is $T_f = T_c \times 1.8 + 32$.)

Once the compressor is energized, there should be a minimum interval of 3 minutes between two start-ups. But if the unit is de-energized and then energized, the compressor can restart within 3 minutes.

2.1 Cooling mode

2.1.1 Cooling conditions and process

When $T_{\text{amb.}} > T_{\text{preset}} + 1^\circ\text{C}$, the unit starts cooling operation. In this case, the compressor and the outdoor fan operate and the indoor fan operates at set speed.

When $T_{\text{amb.}} > T_{\text{preset}} - 1^\circ\text{C}$, the compressor and the outdoor fan stop while the indoor fan runs at set speed.

When $T_{\text{preset}} - 1^\circ\text{C} < T_{\text{amb.}} < T_{\text{preset}} + 1^\circ\text{C}$, the unit will maintain its previous running status.

In cooling mode, the four-way valve is de-energized; temperature setting range is $16 \sim 30^\circ\text{C}$; the indoor unit displays operation icon, cooling icon and set temperature.

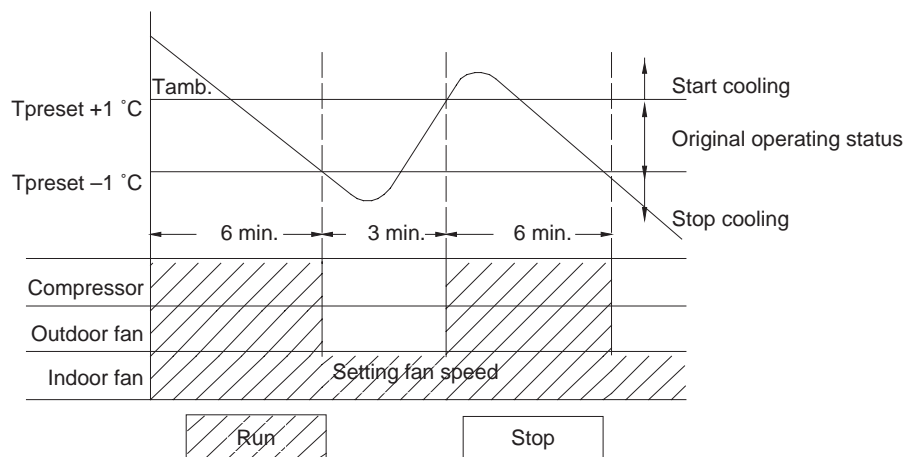

2.1.2 Protection Functions

◆ Freeze protection

If the system is under freeze protection, the compressor and the outdoor fan stop operation, and the indoor fan operates at set speed. If freeze protection is eliminated and the compressor has been out of operation for 3 minutes, the unit will resume its previous running status.

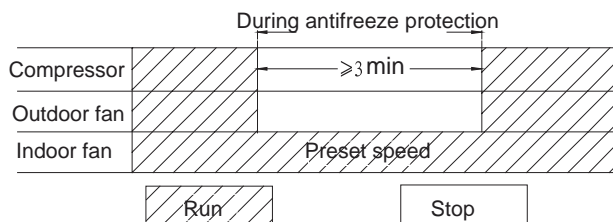

2.1.3 Overcurrent Protection

If the system current exceeds the specified value in 3 successive seconds, the complete unit will stop operation except for the indoor fan. After 3 minutes, if the overcurrent is eliminated, the complete unit will resume previous operation.

If overcurrent protection occurs for 6 successive times (If the compressor operates for 6 minutes continuously, the protective times will be cleared.), the complete unit will stop operation except for the indoor unit. In this case, you are expected to turn off the unit with the remote controller and then restart. During overcurrent protection, the indoor unit displays error code "E5"; the operation indicator lamp blinks (OFF for 3 seconds and blinks 5 times).

2.2 Dry Mode

2.2.1 Dry Conditions and Process

When $T_{amb.} > T_{preset} + 2^{\circ}C$, the unit starts drying and cooling operation. In this case, the compressor and the outdoor fan operate; the indoor fan operates at low speed.

When $T_{preset} - 2^{\circ}C < T_{amb.} < T_{preset} + 2^{\circ}C$, the unit will start drying operation. In this case, the indoor fan operates at low speed; the compressor and the outdoor fan operate for 6 minutes and stop for 4 minutes in cycle.

When $T_{amb.} < T_{preset} - 2^{\circ}C$, the compressor and the outdoor fan stop operation; the indoor fan operates at low speed.

In drying mode, the four-way valve is de-energized; temperature setting range is $16 \sim 30^{\circ}C$; the indoor unit displays operation icon, cooling icon and set temperature.

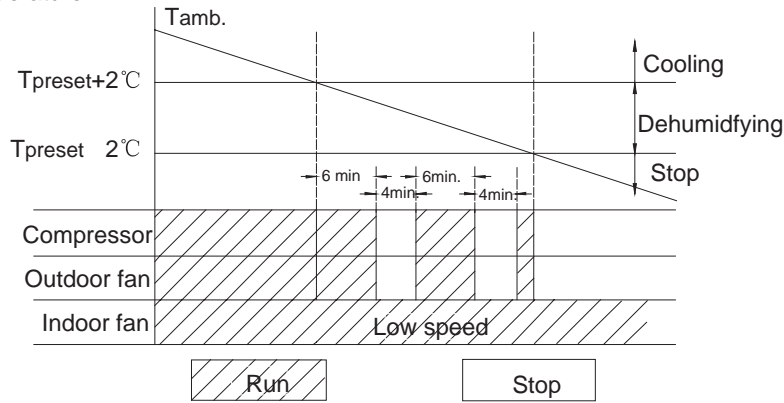

2.2.2 Protection

◆ Freeze protection

During drying and cooling operation, if the system is under freeze protection, the compressor and outdoor fan stop operation while indoor fan operates at low speed. If freeze protection is eliminated and the compressor has been out of operation for 3 minutes, the complete unit will resume its previous running status.

During the cycle of on for 6 min and off for 4 min, if freeze protection is detected, the compressor and the outdoor fan will stop operation; the indoor fan will operate at low speed. When freeze protection is eliminated and the compressor has been out of operation for 4 minutes, the complete unit will resume its previous running status.

2.2.3 Other protection

Other protections are the same as those in cooling mode.

2.3 Heating mode

2.3.1 Heating conditions and process

When $T_{amb.} < T_{preset} - 2^{\circ}C$, the unit starts heating operation. In this case, the 4-way valve, compressor and outdoor fan operate simultaneously; the indoor fan operates with a maximum delay of 2 minutes.

When $T_{amb.} > T_{preset} + 4^{\circ}C$, the compressor and outdoor fan stop operation. The 4-way valve remains energized; the indoor fan blows residual heat.

When $T_{preset} + 2^{\circ}C < T_{amb.} < T_{preset} + 4^{\circ}C$, the unit will maintain its previous running status.

Under this mode, the 4-way valve is energized; temperature setting range is $16 \sim 30^{\circ}C$; the indoor unit displays operation icon, heating icon and set temperature.

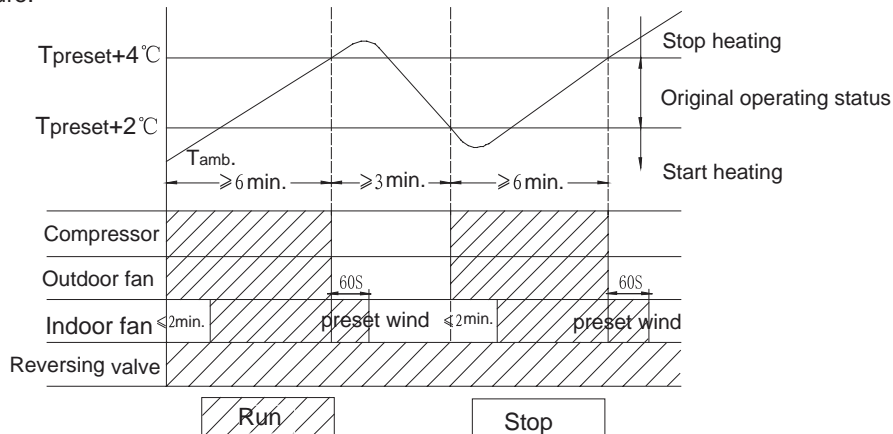

2.3.2 Defrosting Conditions and Process

With intelligent defrosting function, the unit defrosts automatically according to the actual condition. The indoor unit displays "H1".

2.3.3 Protection Functions

◆Overheating Prevention Protection

If the evaporator tube temperature overheats, the outdoor fan stops operation. When the tube temperature returns to normal, the outdoor fan resumes operation.

◆Noise Silencing Protection

If the unit is turned off by pressing ON/OFF button or during mode switchover, the 4-way valve stops with a delay of 2 minutes.

2.3.4 Overcurrent Protection

This protection is the same as that in cooling mode (But indoor fan will blow residual heat).

2.4 Fan mode

In fan mode, indoor fan operates at set speed while the compressor, outdoor fan, 4-way valve and electric heating tube stop operation. In this mode, temperature setting range is 16~30°C. The indoor unit displays operation icon and set temperature.

2.5 Auto Mode

In AUTO mode, the unit will automatically select its operation mode (cooling, heating or fan) with the change of ambient temperature. The indoor unit displays the operation icon, operation mode icon and set temperature. There is a 30-second delay protection for mode switchover. Protection functions are the same as those in any other mode.

3 Other Control

3.1 Timer function

General timer and clock timer functions are compatible by equipping remote controller with different functions.

3.1.1 General Timer

Timer ON can be set at unit OFF. If selected ON time is reached, the unit will start to operate according to previous setting status. Time setting range is 0.5-24hr in 30-minute increments.

Timer OFF can be set at unit ON. If selected OFF time is reached, the unit will stop operation. Time setting range is 0.5-24hr in 30-minute increments.

3.1.2 Clock Timer

Timer ON

If timer ON is set during operation of the unit, the unit will continue to operate. If timer ON is set at unit OFF, upon ON time reaches the unit will start to operate according to previous setting status.

Timer OFF

If timer OFF is set at unit OFF, the system will keep standby status. If timer OFF is set at unit ON, upon OFF time reaches the unit will stop operation.

Timer Change

Although timer has been set, the unit still can be turned on/off by pressing ON/OFF button of the remote controller. You can also set the timer once again, and then the unit will operate according to the last setting.

If timer ON and timer OFF are set at the same time during operation of the unit, the unit will keep operating at current status till OFF time reaches.

If timer ON and timer OFF are set at the same time at unit OFF, the unit will keep off status till ON time reaches.

Each day in future, the system will operate according to preset mode till OFF time reaches and stop operation till ON time reaches. If ON time and OFF time are the same, OFF command will prevail.

3.2 Auto Button

If this button is pressed, the unit will operate in AUTO mode and indoor fan will operate at auto speed; meanwhile, the swing motor operates. Press this button again to turn off the unit.

3.3 Buzzer

Upon energization or availably operating the unit or remote controller, the buzzer will give out a beep.

3.4 Sleep Function

In SLEEP mode, the unit will automatically select appropriate sleep curve to operate according to different temperature setting.

3.5 Turbo Function

This function can be set in cooling or heating mode to quickly cool or heat the room.

3.6 X-FAN Function

This function can be set in COOL or DRY mode.

3.7 Automatic Control of Fan Speed

In this mode, the indoor fan will automatically select high, medium or low speed with the change of ambient temperature.

3.8 Up & Down Swing

After energization, up & down swing motor will firstly have the horizontal louver rotate anticlockwise to position 0 to close air outlet.

If swing function has not been set after startup of the unit, horizontal louver will turn clockwise to position D in HEAT mode, or turn clockwise to level position L in other modes.

If swing function is set when starting up the unit, the horizontal louver will swing between L and D.

There are 7 swing status of horizontal louver: Positions L, A, B, C and D, swing between L and D and stop at any position between L and D (angles between L and D are equiangular).

Upon turning off the unit, the horizontal louver will close at position 0. Swing function is available only when swing function is set and indoor fan is operating.

Note: If the position is set between L and B, A and C or B and D by remote controller, the horizontal louver will swing between L and D.

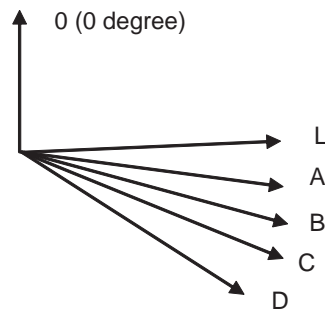

3.9 Display

3.9.1 Operation and Mode Icons

Upon energization, the unit will display all icons. Under standby state, running indicating mark is displayed in red. If the unit is started by remote controller, running indicating mark gives off light; meanwhile, the mark of current running mode will be displayed (mode LED: cooling, heating and dry mode). If the light button is turned off, no mark will be displayed.

3.9.2 Display of Nixie Tube on Indoor Unit

When energized & started for the first time, the indoor unit defaults to displaying current set temperature (16~30°C). When set temperature display is set by remote controller, it will display set temperature; when room temperature display is set, it will display room temperature. After that, when operating the remote controller for other settings, the temperature display method will keep original.

When operating the remote controller during room temperature display, the set temperature will be displayed for 5 seconds firstly and then room temperature display returns.

“F1” will be displayed upon malfunction of room temperature sensor, “F2” upon malfunction of indoor unit tube temperature sensor and “C5” upon malfunction of jumper cap.

For some models, if set temperature display is set by the remote controller, current set temperature will be displayed. After that, when switching to room temperature display from set temperature or outdoor temperature by the remote controller, room temperature will be displayed for 5 seconds firstly and then set temperature display returns.

3.10 Locked protection to PG motor

If the indoor fan motor keeps low rotation speed for a continuous period of time after startup, the unit will stop operation and display “H6”.

3.11 Memory Function

Memorized items: mode, up & down swing, light, set temperature and set fan speed.

When power is recovered after power failure, the unit will automatically start operation according to memorized status. After power recovery, the unit without timer setting before power failure will operate according to the last setting; the unit with general timer setting which has not been fulfilled before power failure will memorize the timer setting and re-calculate the time after.

4 Special functions(Optional)

4.1 HEALTH function

During operation of the indoor unit fan, press HEALTH button on the remote controller to start health function (If there is not HEALTH button on the remote controller, the unit defaults health function ON).

4.2 I FEEL function

When I FEEL command is received, the controller will operate according to the ambient temperature sent by the remote controller (For defrosting and cold blow prevention, the unit operates according to the ambient temperature sensed by the air conditioner). The remote controller will regularly send ambient temperature data to the controller. When the data has not been received for a long time, the unit will operate according to the temperature sensed by the air conditioner. If I FEEL function is not selected, the ambient temperature will be that sensed by the air conditioner. I FEEL function is not to be memorized.

7. Installation Manual

7.1 Notices for Installation

Caution

- 1.The unit should be installed only by authorized service center according to local or government regulations and in compliance with this manual.
- 2.Before installing, please contact with local authorized maintenance center. If the unit is not installed by the authorized service center, the malfunction may not be solved due to inconvenient contact between the user and the service personnel.
- 3.When removing the unit to the other place, please firstly contact with the local authorized service center.
- 4.Warning: Before obtaining access to terminals, all supply circuits must be disconnected.
- 5.For appliances with type Y attachment, the instructions shall contain the substance of the following. If the supply cord is damaged, it must be replaced by the manufacturer, its service agent or similarly qualified persons in order to avoid a hazard.
- 6.The appliance must be positioned so that the plug is accessible.
- 7.The temperature of refrigerant line will be high; please keep the interconnection cable away from the copper tube.
- 8.The instructions shall state the substance of the following:
This appliance is not intended for use by persons(including children)with reduced physical, sensory or mental capabilities, or lack of experience and knowledge, unless they have been given supervision or instruction concerning use of the appliance by a person responsible for their safety.
Children should be supervised to ensure that they do not play with the appliance.

7.1.1 Installation Site Instructions

Proper installation site is vital for correct and efficient operation of the unit. Avoid the following sites where:

- strong heat sources, vapours, flammable gas or volatile liquids are emitted.
- high-frequency electro-magnetic waves are generated by radio equipment,welders and medical equipment.
- salt-laden air prevails (such as close to coastal areas).
- the air is contaminated with industrial vapours and oils.
- the air contains sulphures gas such as in hot spring zones.
- corrosion or poor air quality exists.

7.1.2 Installation Site of Indoor Unit

- 1.The air inlet and outlet should be away from the obstructions. Ensure the air can be blown through the whole room.
- 2.Select a site where the condensate can be easily drained out, and where it is easily connected to outdoor unit.
- 3.Select a place where it is out of reach of children.
- 4.Select a place where the wall is strong enough to withstand the full weight and vibration of the unit.
- 5.Be sure to leave enough space to allow access for routine maintenance. The installation site should be 250cm or more above the floor.
- 6.Select a place about 1m or more away from TV set or any other electric appliance.
- 7.Select a place where the filter can be easily taken out.
- 8.Make sure that the indoor unit is installed in accordance with installation dimension instructions.
- 9.Do not use the unit in the laundry or by swimming pool etc.

7.1.3 Installation Site of Outdoor Unit

- 1.Select a site where noise and outflow air emitted by the unit will not annoy neighbors.
- 2.Select a site where there is sufficient ventilation.
- 3.Select a site where there is no obstruction blocking the inlet and outlet.
- 4.The site should be able to withstand the full weight and vibration.
- 5.Select a dry place, but do not expose the unit to direct sunlight or strong wind.
- 6.Make sure that the outdoor unit is installed in accordance with the installation instructions, and is convenient for maintenance and repair.
- 7.The height difference between indoor and outdoor units is within 10 m, and the length of the connecting tubing does not exceed 25 m.
- 8.Select a place where it is out of reach of children.
- 9.Select a place where the unit does not have negative impact on pedestrians or on the city.

7.1.4 Safety Precautions for Electric Appliances

1. A dedicated power supply circuit should be used in accordance with local electrical safety regulations.
2. Don't drag the power cord with excessive force.
3. The unit should be reliably earthed and connected to an exclusive earth device by the professionals.
4. The air switch must have the functions of magnetic tripping and heat tripping to prevent short circuit and overload.
5. The minimum distance between the unit and combustible surface is 1.5m.
6. The appliance shall be installed in accordance with national wiring regulations.
7. An all-pole disconnection switch with a contact separation of at least 3mm in all poles should be connected in fixed wiring.

Note:

- Make sure the live wire, neutral wire and earth wire in the family power socket are properly connected.
- There should be reliable circuit in the diagram. Inadequate or incorrect electrical connections may cause electric shock or fire.

7.1.5 Earthing Requirements

1. Air conditioner is type I electric appliance. Please ensure that the unit is reliably earthed.
2. The yellow-green wire in air conditioner is the earthing wire which can not be used for other purposes. Improper earthing may cause electric shock.
3. The earth resistance should accord to the national criterion.
4. The power must have reliable earthing terminal. Please do not connect the earthing wire with the following:
① Water pipe ② Gas pipe ③ Contamination pipe ④ Other place that professional personnel consider is unreliable
5. The model and rated values of fuses should accord with the silk print on fuse cover or related PCB.

7.2 Installation Drawing

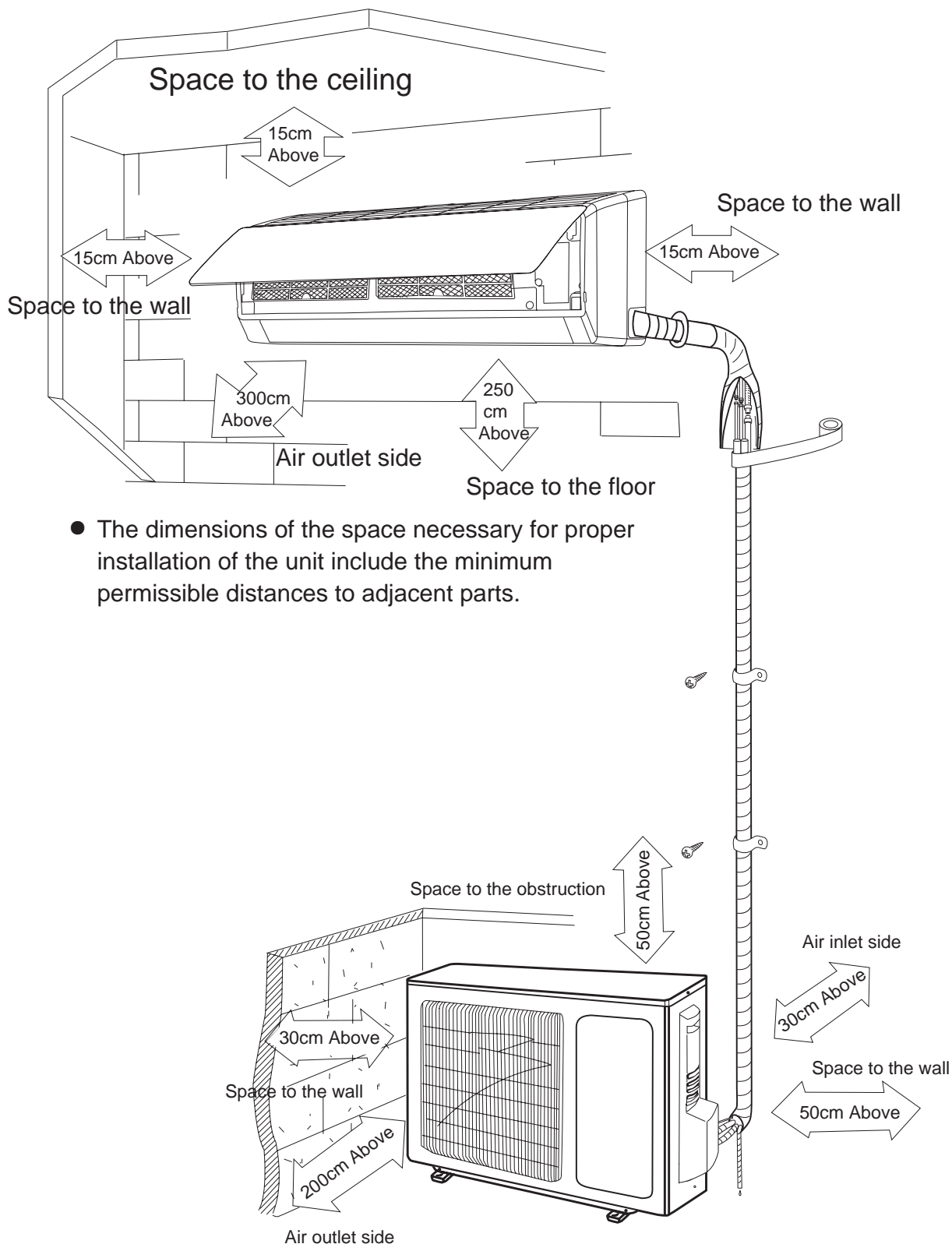

- The dimensions of the space necessary for proper installation of the unit include the minimum permissible distances to adjacent parts.

Schematic diagram being reference only (outdoor unit is with variation), please refer to real product for authentic information.

7.3 Install Indoor Unit

7.3.1 Installation of Mounting Plate

1. Mounting plate should be installed horizontally. As the water tray's outlet for the indoor unit is two-way type, during installation, the indoor unit should slightly slant to water tray's outlet for smooth drainage of condensate.
2. Fix the mounting plate on the wall with screws.
3. Be sure that the mounting plate has been fixed firmly enough to withstand about 60 kg. Meanwhile, the weight should be evenly shared by each screw.

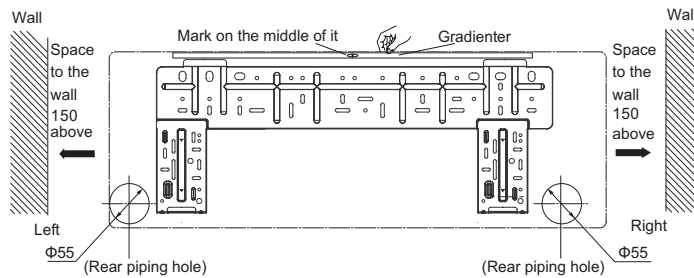

7.3.2 Drill Piping Hole

1. Slant the piping hole (Φ55) on the wall slightly downward to the outdoor side.
2. Insert the piping-hole sleeve into the hole to prevent the connection piping and wiring from being damaged when passing through the hole.

7.3.3 Installation of Drain Hose

1. Connect the drain hose to the outlet pipe of the indoor unit. Bind the joint with rubber belt.
2. Put the drain hose into insulating tube.
3. Wrap the insulating tube with wide rubber belt from the joint of outlet pipe and insulating pipe so as to prevent shift of insulating tube. The drain hose should be placed at a downward slant for easy discharge of condensate.

Note: the insulating tube should be connected reliably with the sleeve outside the outlet pipe. The drain hose should be downward slant, without distortion, bulge or fluctuation. Do not put the water outlet in the water.

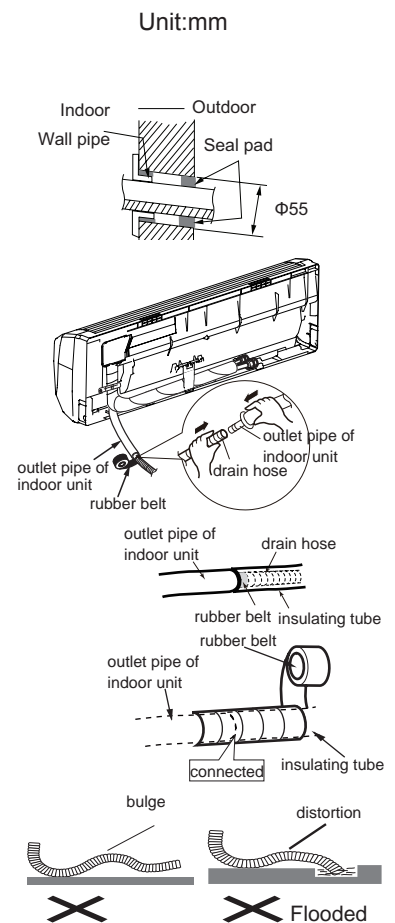

7.3.4 Connecting Indoor and Outdoor Electric Wires

1. Open the front panel.
2. Remove the wiring cover. Connect and fix power connection cord and signal control wire to the terminal board. As shown in Fig.2.
3. Make the power connection cord and signal control wire through the hole in the back of indoor unit.
4. Reinstall the cord anchorage and wiring cover.
5. Reinstall the front panel.

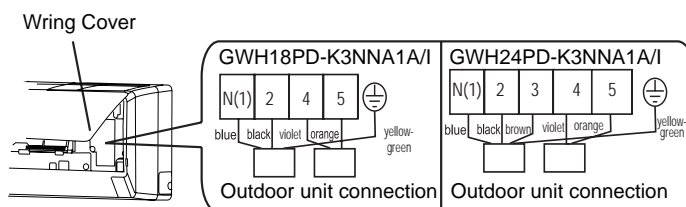

Fig.2

NOTE:

All wires between indoor and outdoor units must be connected by the qualified electric contractor.

- Electric wires must be connected correctly. Improper connection may cause malfunction.
- Tighten the terminal screws securely.
- After tightening the screws, pull the wire slightly to confirm whether it's firm or not.
- Make sure that the electric connections are earthed properly to prevent electric shock.
- Make sure that all wiring connections are secure and the cover plates are reinstalled properly. Poor installation may cause fire or electric shock.

7.3.5 Installation of Indoor Unit

• The piping can be output from right, right rear, left or left rear.

1. When routing the piping and wiring from the left or right side of indoor unit, cut off the tailings from the chassis when necessary (As shown in Fig.3)

- (1) Cut off the tailing 1 when routing the wiring only;
- (2) Cut off the tailing 1 and tailing 2 when routing both the wiring and piping.

2. Take out the piping from body case, wrap the piping, power cords, drain hose with the tape and make them through the piping hole. (As shown in Fig.4)

3. Hang the mounting slots of the indoor unit on the upper hooks of the mounting plate and check if it is firm enough. (As shown in Fig.5)

4. The installation site should be 250cm or more above the floor.

7.3.6 Installation of Connection Pipe

1. Align the center of the pipe flare with the relevant valve.
2. Screw in the flare nut by hand and then tighten the nut with spanner and torque wrench referring to the following:

Hex nut diameter	Tightening torque (N·m)
Φ6	15~20
Φ 9.52	31~35
Φ 12	50~55
Φ 16	60~65
Φ 19	70~75

NOTE:

Connect the connection pipe to indoor unit at first and then to outdoor unit. Handle piping bending with care. Do not damage the connection pipe. Ensure that the joint nut is tightened firmly, otherwise, it may cause leakage.

7.4 Installation of Outdoor Unit

7.4.1 Electric Wiring

1. Remove the handle of outdoor unit.
2. Take off wire cord anchorage. Connect and fix power connection cord and signal control wire to the terminal board. Wiring should fit that of indoor unit.
3. Fix the power connection cord and signal control wire with wire clamps and then connect the corresponding connector.
4. Confirm if the wire has been fixed properly.
5. Reinstall the handle .

NOTE:

- Incorrect wiring may cause malfunction of spare part.
- After the wire has been fixed, ensure there is free space between the connection and fixing places on the lead wire.

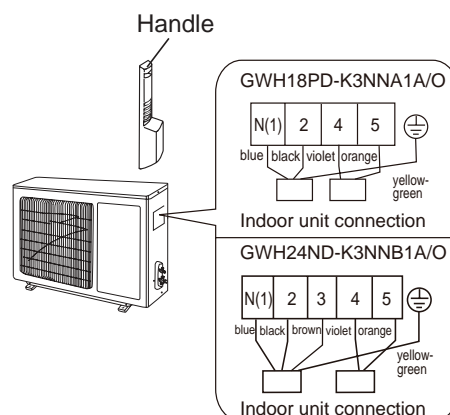
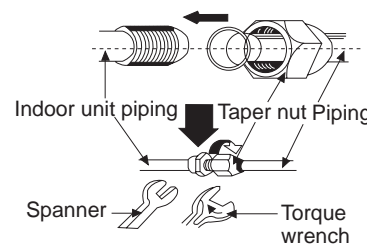
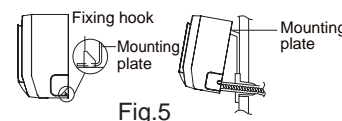
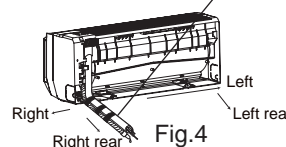
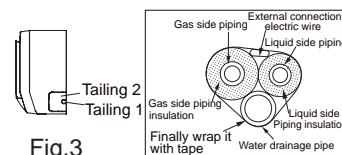

7.4.2 Air Purging and Leakage Test

1. Connect charging hose of manifold valve to charge end of low pressure valve (both high/low pressure valves must be tightly shut).
2. Connect joint of charging hose to vacuum pump.
3. Fully open the handle of Lo manifold valve.
4. Open the vacuum pump for vacuumization. At the beginning, slightly loosen joint nut of low pressure valve to check if there is air coming inside. (If noise of vacuum pump has been changed, the reading of multimeter is 0) Then tighten the nut.
5. Keep evacuating for more than 15mins and make sure the reading of multi-meter is -1.0×10^5 pa(-76cmHg).
6. Fully open high/low pressure valves.
7. Remove charging hose from charging end of low pressure valve.
8. Tighten bonnet of low pressure valve. (As shown in Fig.6)

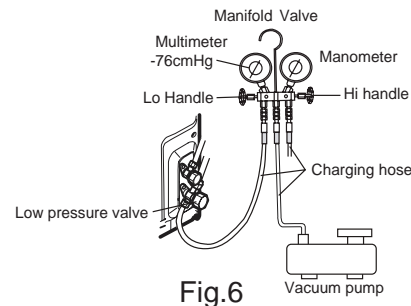

7.4.3 Outdoor condensate Drainage (only for heat pump type)

During heating operation, the condensate and defrosting water should be drained out reliably through the drain hose. Install the outdoor drain connector in a $\Phi 25$ hole on the base plate and attach the drain hose to the connector so that the waste water formed in the outdoor unit can be drained out. The hole diameter 25 must be plugged. Whether to plug other holes will be determined by the dealers according to actual conditions.

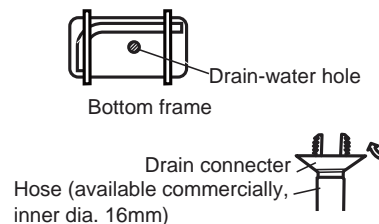

7.5 Check after Installation and Test Operation

7.5.1 Check after Installation

Items to be checked	Possible malfunction
Has the unit been fixed firmly?	The unit may drop, shake or emit noise.
Have you done the refrigerant leakage test?	It may cause insufficient cooling(heating)
Is thermal insulation sufficient?	It may cause condensation.
Is water drainage satisfactory?	It may cause water leakage.
Is the voltage in accordance with the rated voltage marked on the nameplate?	It may cause electric malfunction or damage the unit.
Is the electric wiring or piping connection installed correctly and securely?	It may cause electric malfunction or damage the parts.
Has the unit been securely earthed?	It may cause electrical leakage.
Is the power cord specified?	It may cause electric malfunction or damage the parts.
Is the inlet or outlet blocked?	It may cause insufficient cooling(heating)
Is the length of connection pipes and refrigerant capacity recorded?	The refrigerant capacity is not accurate.

7.5.2 Operation Test

1. Before Operation Test

- (1) Do not switch on power before installation is finished completely.
- (2) Electric wiring must be connected correctly and securely.
- (3) Cut-off valves of the connection pipes should be opened.
- (4) All the impurities such as scraps and thrums must be cleared from the unit.

2. Operation Test Method

- (1) Switch on power and press "ON/OFF" button on the wireless remote controller to start the operation.
- (2) Press MODE button to select the COOL, HEAT (Not available for cooling only unit), FAN to check whether the operation is normal or not.

7.6 Installation and Maintenance of Healthy Filter

7.6.1 Installation of Healthy Filter

1. Lift up the front panel from its two ends, as shown by the arrow direction, and then remove the air filter. (as shown Fig.a)

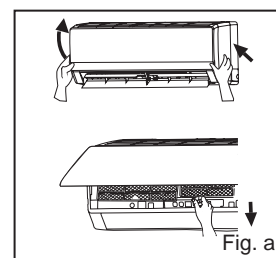

2. Attach the healthy filter onto the air filter, (as shown Fig.b).

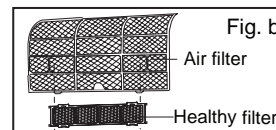

3. Install the air filter properly along the arrow direction in Fig.c, and then close the panel.

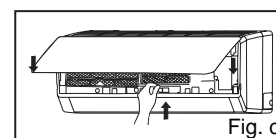

7.6.2 Cleaning and Maintenance

Remove the healthy filter and reinstall it after cleaning according to the installation instruction. Do not use brush or hard objects to clean the filter. After cleaning, be sure to dry it in the shade.

7.6.3 Service Life

The general service life for the healthy filter is about one year under normal condition. As for silver ion filter, it is ineffective when its surface becomes black (green).

● This supplementary instruction is provided for reference to the unit with healthy filter. If the graphics provided herein are different from the actual product, please refer to the actual product. The quantity of healthy filters is based on the actual delivery.

8. Exploded Views and Parts List

8.1 Indoor Unit

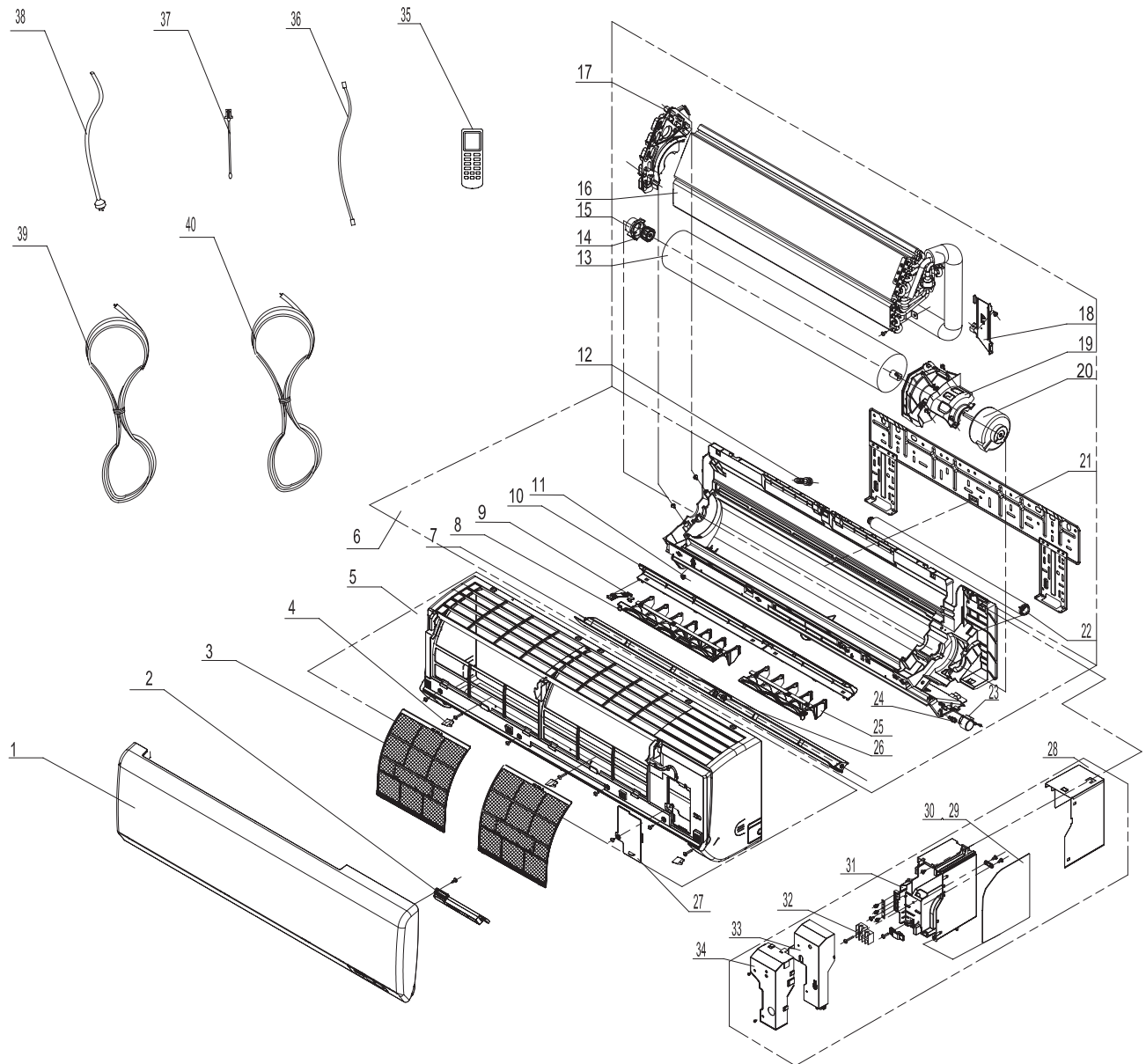

NO.	Description	Part Code		Qty
		GWH18PD-K3NNA1A/I		
		Product code	CA414N00100	
1	Front Panel Assy	20022280	20022279	1
2	Display Board	30565208	30565200	1
3	Filter Sub-Assy	1112208901	1112208901	2
4	Screw Cover	24252016	24252016	3
5	Front Case Sub-assy	20012667	20012667	1
6	Rear Case assy	22202193	22202193	1
7	Guide Louver	10512205	10512205	1
8	Air Louver 1	1051211602	1051211602	1
9	Baffle Plate	2611222802	2611222802	1
10	Helicoid Tongue	2611223802	2611223802	1
11	Left Axile Bush	10512037	10512037	1
12	Rubber Plug (Water Tray)	76712012	76712012	1
13	Cross Flow Fan	10352019	10352019	1
14	O-Gasket sub-assy of Bearing	76512051	76512051	1
15	Ring of Bearing	26152022	26152022	1
16	Evaporator Assy	01002937	01002937	1
17	Evaporator Support	24212133	24212133	1
18	Pipe Clamp	2611216401	2611216401	1
19	Motor Press Plate	26112494	26112494	1
20	Fan Motor	15012116	15012116	1
21	Wall Mounting Frame	01252218	01252218	1
22	Drainage Hose	05230014	05230014	1
23	Step Motor	15012086	15012086	1
24	Crank	10582070	10582070	1
25	Air Louver 2	1051211702	1051211702	1
26	Axile Bush	10542036	10542036	1
27	Electric Box Cover2	20122142	20122142	1
28	Electric Box Assy	2030248801	20302488	1
29	Main Board	30135849	30135610	1
30	Jumper	4202300106	4202300106	1
31	Electric Box	20112108	20112108	1
32	Terminal Board	42010268	42010268	1
33	Electric Box Cover1	20122154	20122154	1
34	Shield Cover of Electric Box	01592102	01592102	1
35	Remote Controller	30510425	30510425	1
36	Ambient Temperature Sensor	390000451	390000451	1
37	Tube Sensor	390000591	390000591	1
38	Power Cord	4002048716	4002048716	1
39	Connecting Cable	400205402	400205402	0
40	Connecting Cable	4002053603	4002053603	0

The data above are subject to change without notice.

Exploded Views and Parts List

NO.	Description	Part Code		Qty
		GWH24PD-K3NNA1A/I		
		Product code	CA414N00201	
1	Front Panel Assy	20022279	20022280	1
2	Display Board	30565200	30565208	1
3	Filter Sub-Assy	1112208901	1112208901	2
4	Screw Cover	24252016	24252016	3
5	Front Case Sub-assy	2001266702	2001266702	1
6	Rear Case assy	22202193	22202193	1
7	Guide Louver	10512205	10512205	1
8	Air Louver 1	1051211602	1051211602	1
9	Baffle Plate	2611222802	2611222802	1
10	Helicoid Tongue	2611223802	2611223802	1
11	Left Axile Bush	10512037	10512037	1
12	Rubber Plug (Water Tray)	76712012	76712012	1
13	Cross Flow Fan	10352019	10352019	1
14	O-Gasket sub-assy of Bearing	76512051	76512051	1
15	Ring of Bearing	26152022	26152022	1
16	Evaporator Assy	01002937	01002937	1
17	Evaporator Support	24212133	24212133	1
18	Pipe Clamp	2611216401	2611216401	1
19	Motor Press Plate	26112494	26112494	1
20	Fan Motor	15012116	15012116	1
21	Wall Mounting Frame	01252218	01252218	1
22	Drainage Hose	05230014	05230014	1
23	Step Motor	15012086	15012086	1
24	Crank	10582070	10582070	1
25	Air Louver 2	1051211702	1051211702	1
26	Axile Bush	10542036	10542036	1
27	Electric Box Cover2	20122142	20122142	1
28	Electric Box Assy	2030248802	2030248802	1
29	Main Board	30135757	30135869	1
30	Jumper	4202300106	4202300106	1
31	Electric Box	20112108	20112108	1
32	Terminal Board	4201026201	4201026201	1
33	Electric Box Cover1	20122154	20122154	1
34	Shield Cover of Electric Box	01592102	01592102	1
35	Remote Controller	30510425	30510425	1
36	Ambient Temperature Sensor	390000451	390000451	1
37	Tube Sensor	390000591	390000591	1
38	Power Cord	400203253	400203253	1
39	Connecting Cable	400205382	400205382	0
40	Connecting Cable	4002053603	4002053603	0

The data above are subject to change without notice.

8.2 Outdoor Unit

GWH18PD-K3NNA1A/O

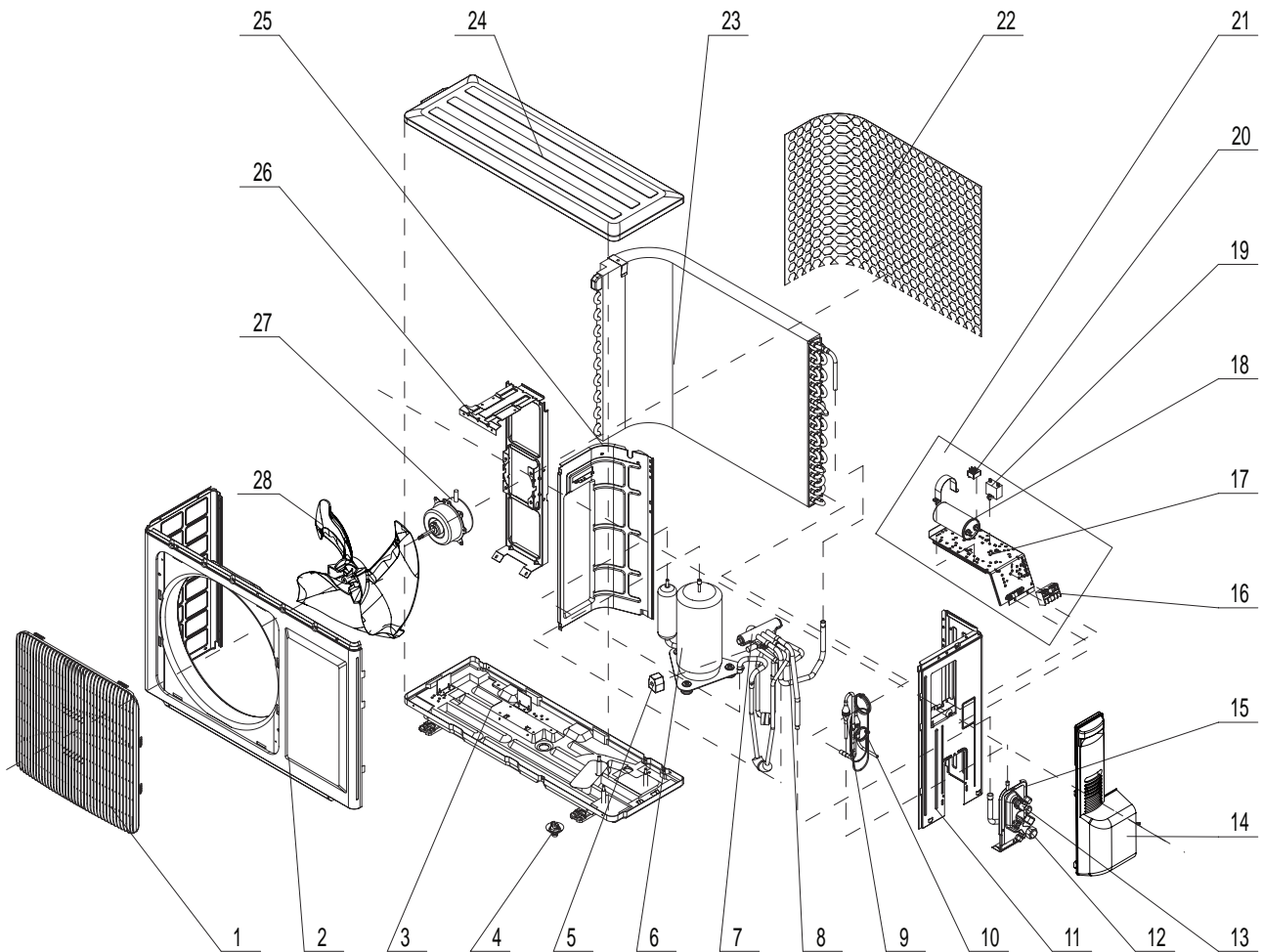

Exploded Views and Parts List

NO.	Description	Part Code		Qty
		GWH18PD-K3NNA1A/O	GWH18PD-K3NNA1A/O	
	Product code	CA414W00100	CA414W00102	
1	Front Grill	22413433	22413433	1
2	Front Panel	0153303204P	0153303204P	1
3	Chassis Sub-assy	012032134	0120324510	1
4	Drainage Connector	06123401	06123401	1
5	Magnet Coil	43000400	43000400	1
6	Compressor and Fittings	00120023	00103891	1
7	4-Way Valve	430004032	430004032	1
8	4-Way Valve Assy	03123303	03123986	1
9	StrainerA	07210022	07210022	1
10	Capillary Sub-assy	03103911	03163101	1
11	Right Side Plate Assy	0130200404	0130200404	1
12	Valve	07100004	07100004	1
13	Valve	07100006	07100006	1
14	Big Handle	26233433	26233433	1
15	Valve Support	01713041	01713041	1
16	Terminal Board	42010265	42010265	1
17	Electric Box Sub-Assy	01403117	01403117	1
18	Capacitor CBB65	33010743	3300008108	1
19	Capacitor CBB61	33010026	33010026	1
20	Terminal Board	42010265	42010265	1
21	Electric Box Assy	02603994	02613325	1
22	Rear Grill	11123205	11123205	1
23	Condenser Assy	01113359	01163672	1
24	Top Cover Plate	01253443	01253443	1
25	Clapboard Sub-Assy	012334172	012334172	1
26	Motor Support Sub-Assy	0170310301	0170310301	1
27	Fan Motor	150130676	150130676	1
28	Axial Flow Fan	10333427	10333427	1

The data above are subject to change without notice.

GWH24ND-K3NNB1A/O

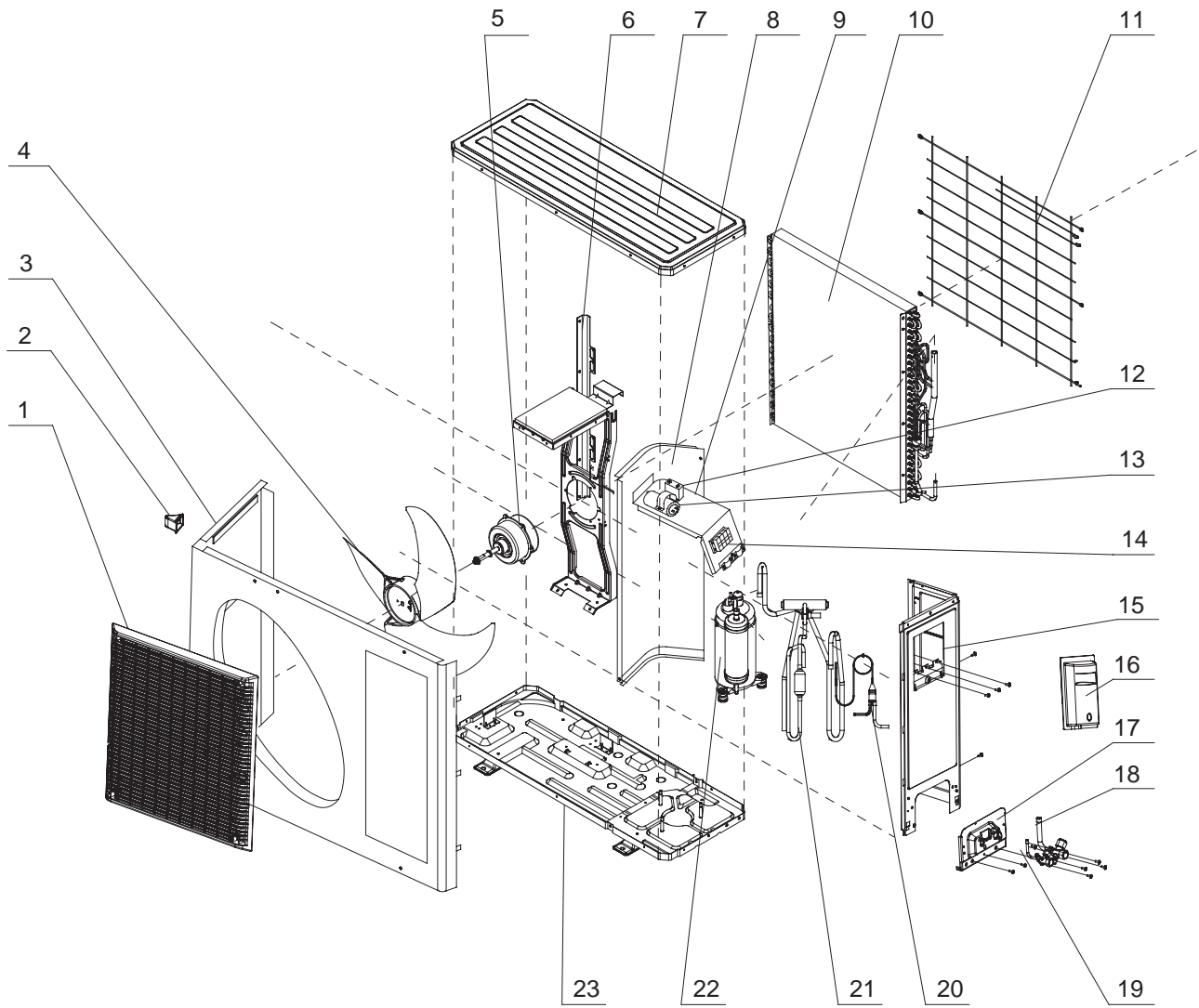

Exploded Views and Parts List

NO.	Description	Part Code	
		GWH24ND-K3NNB1A/O	
		CA136W0042	
1	Front grill	22415001	1
2	Left Handle	26235401	1
3	Front Panel	01305015	1
4	Axial Flow Fan	10335257	1
5	Fan Motor	15015057	1
6	Motor Support Sub-Assy	0170305901	1
7	Top Cover	01255001	1
8	Clapboard Sub-Assy	01233035	1
9	Electric Box Assy	02603219	1
10	Condenser Assy	01113396	1
11	Rear Grill	0147500401	1
12	Capacitor CBB61	33010027	1
13	Capacitor CBB65	33000039	1
14	Terminal Board	420101941	1
15	Right Side Plate	01305095P	1
16	Handle	26235254	1
17	Valve Support Sub-Assy	01713075	1
18	Valve	07130213	1
19	Valve	07100003	1
20	Capillary Sub-assy	03103946	1
21	4-Way Valve Assy	03123248	1
22	Compressor and Fittings	00103702	1
23	Chassis Sub-assy	0120362602P	1

The data above are subject to change without notice.

9. Troubleshooting

9.1 Precautions before Performing Inspection or Repair

Be cautious during installation and maintenance. Do operation following the regulations to avoid electricshock and casualty oreven death due to drop from high attitude.

* Static maintenance is the maintenance during de-energization of the air conditioner.For static maintenance, make sure that the unit is de-energized and the plug is disconnected.

* dynamic maintenance is the maintenance during energization of the unit.Before dynamic maintenance, check the electricity and ensure that there is ground wire on the site. Check if there is electricity on the housing and connection copper pipe of the air conditioner with voltage tester. After ensure insulation placeand the safety, the maintenance can be performed.

Take sufficient care to avoid directly touching any of the circuit parts without first turning off the power.

At times such as when the circuit board is to be replaced, place the circuit board assembly in a vertical position.

Normally,diagnose troubles according to the trouble diagnosis procedure as described below.(Refer to the check points in servicing written on the wiring diagrams attached to the indoor/outdoor units.)

No.	Troubleshooting procedure
1	Confirmation
2	Judgement by Flashing LED of Indoor/Outdoor Unit
3	How to Check simply the main part

9.2 Confirmation

(1)Confirmation of Power Supply

Confirm that the power breaker operates(ON) normally;

(2)Confirmation of Power Voltage

Confirm that power voltage is AC 220-230-240 ±10%.

If power voltage is not in this range, the unit may not operate normally.

9.3 Judgement by Flashing LED of Indoor/Outdoor Unit

Note:GWH18PD-K3NNA1A(CA414000100) GWH24PD-K3NNA1A(CA414000202) 无双八显示。

No.	Malfunction Name	Display Method of Indoor Unit			A/C Status	Possible Causes
		Error Code	Indicator lamp (During blinking, ON for 0.5S and OFF for 0.5 S)			
			Operation Lamp	COOL Lamp		
1	Indoor ambient temperature sensor is open/short circuited	F1		OFF 3S and blinks once	The unit will stop operation as it reaches the temperature point. During cooling and drying operation, except indoor fan operates, other loads (such as compressor, outdoor fan, 4-way valve) stop operation; During heating operation, the complete unit stops operation.	<ol style="list-style-type: none"> 1. The wiring terminal between indoor ambient temperature sensor and controller is loosened or poorly contacted; 2. There's short circuit due to trip-over of the parts on controller; 3. Indoor ambient temperature sensor is damaged (Please check it by referring to the resistance table for temperature sensor) 4. Main board is broken.
2	Indoor evaporator temperature sensor is open/short-circuited	F2		OFF 3S and blinks twice	The unit will stop operation as it reaches the temperature point. During cooling and drying operation, except indoor fan operates, other loads stop operation; During heating operation, the complete unit stops operation.	<ol style="list-style-type: none"> 1. The wiring terminal between indoor evaporator temperature sensor and controller is loosened or poorly contacted; 2. There's short circuit due to the trip-over of the parts on controller; 3. Indoor evaporator temperature sensor is damaged (Please check it by referring to the resistance table for temperature sensor) 4. Main board is broken.
3	PG motor (indoor fan motor) does not operate	H6	OFF 3S and blinks 11 times		Indoor fan, outdoor fan, compressor and electric heat tube stop operation. 2 minutes later, 4-way valve stops; horizontal louver stops at the current position.	<ol style="list-style-type: none"> 1. The feedback terminal of PG motor is not connected tightly. 2. The control terminal of PG motor is not connected tightly. 3. Fan blade rotates unsmoothly due to improper installation. 4. Motor is not installed properly and tightly. 5. Motor is damaged. 6. Controller is damaged.
4	Malfunction protection of jumper cap	C5	OFF 3S and blinks 15 times		Operation of remote controller or control panel is available, but the unit won't act.	<ol style="list-style-type: none"> 1. There's not jumper cap on the controller. 2. Jumper cap is not inserted properly and tightly. 3. Jumper cap is damaged. 4. Controller is damaged.
5	Overcurrent protection	E5	OFF 3S and blinks 5 times		During cooling and drying operation, compressor and outdoor fan stop while indoor fan operates. During heating operation, all loads stop.	<ol style="list-style-type: none"> 1. Unstable supply voltage. Normal fluctuation shall be within 10% of the rated voltage on the nameplate. 2. Supply voltage is too low and load is too high. 3. Measure the current of live wire on main board. If the current isn't higher than the overcurrent protection value, please check the controller. 4. The indoor and outdoor heat exchangers are too dirty, or the air inlet and air outlet are blocked. 5. The fan motor is not running. Abnormal fan speed: fan speed is too low or the fan doesn't run 6. The compressor is not running normally. There is abnormal sound, oil leakage or the temperature of the shell is too high, etc. 7. There's blockage in the system (filth blockage, ice plug, greasy blockage, Y-valve hasn't been opened completely)

9.4 How to Check Simply the Main Part

(1) Malfunction of temperature sensor

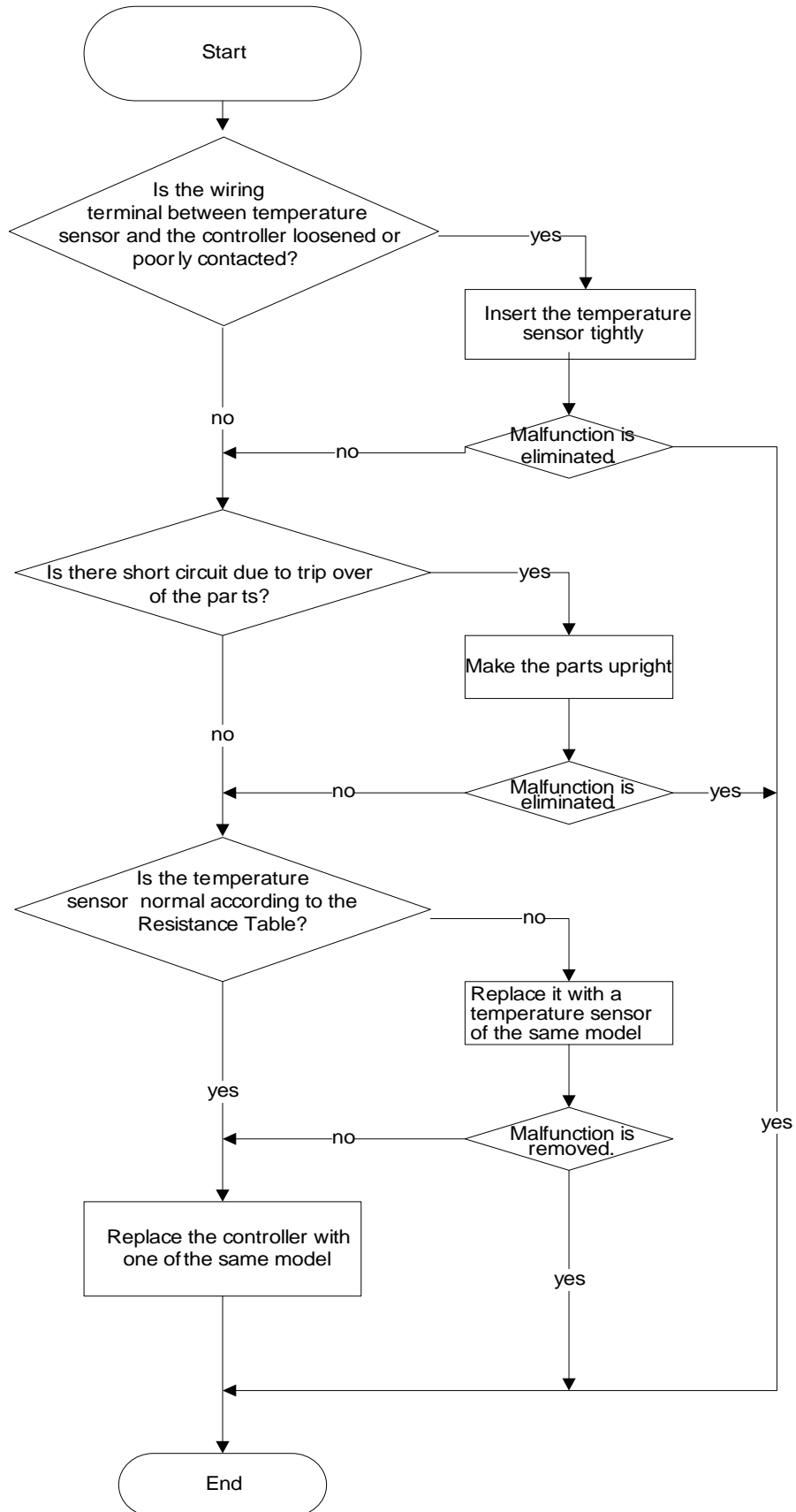

(2) PG motor (indoor fan) does not operate (H6)

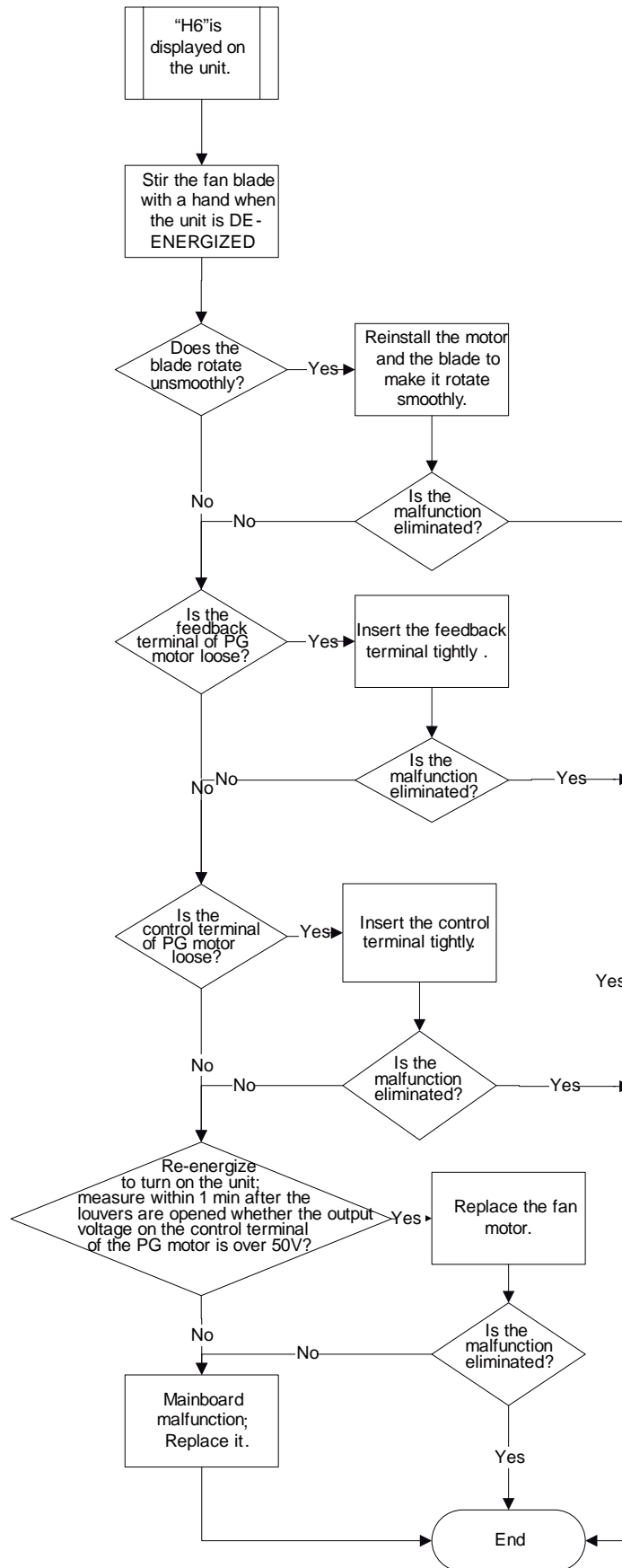

(3) Jumper cap malfunction (C5)

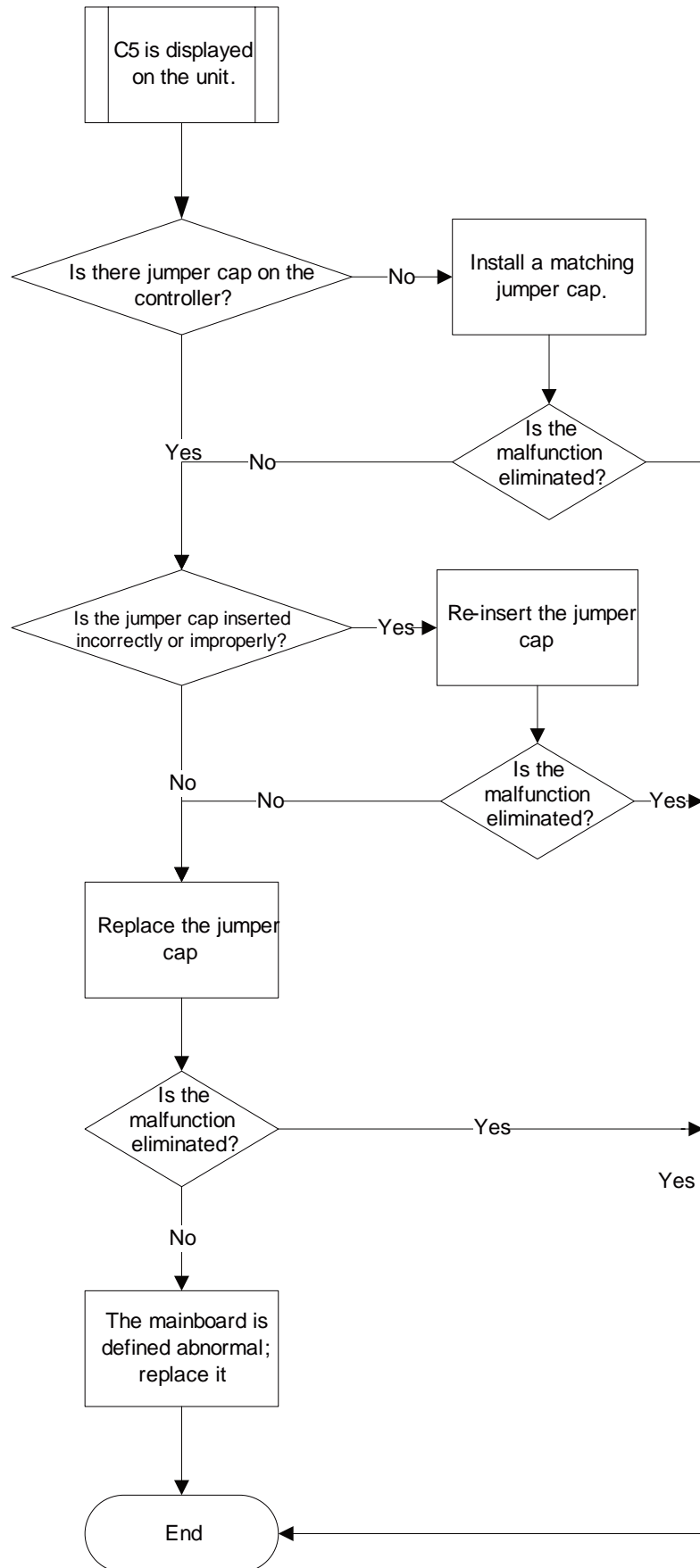

(4)E5 Malfunction

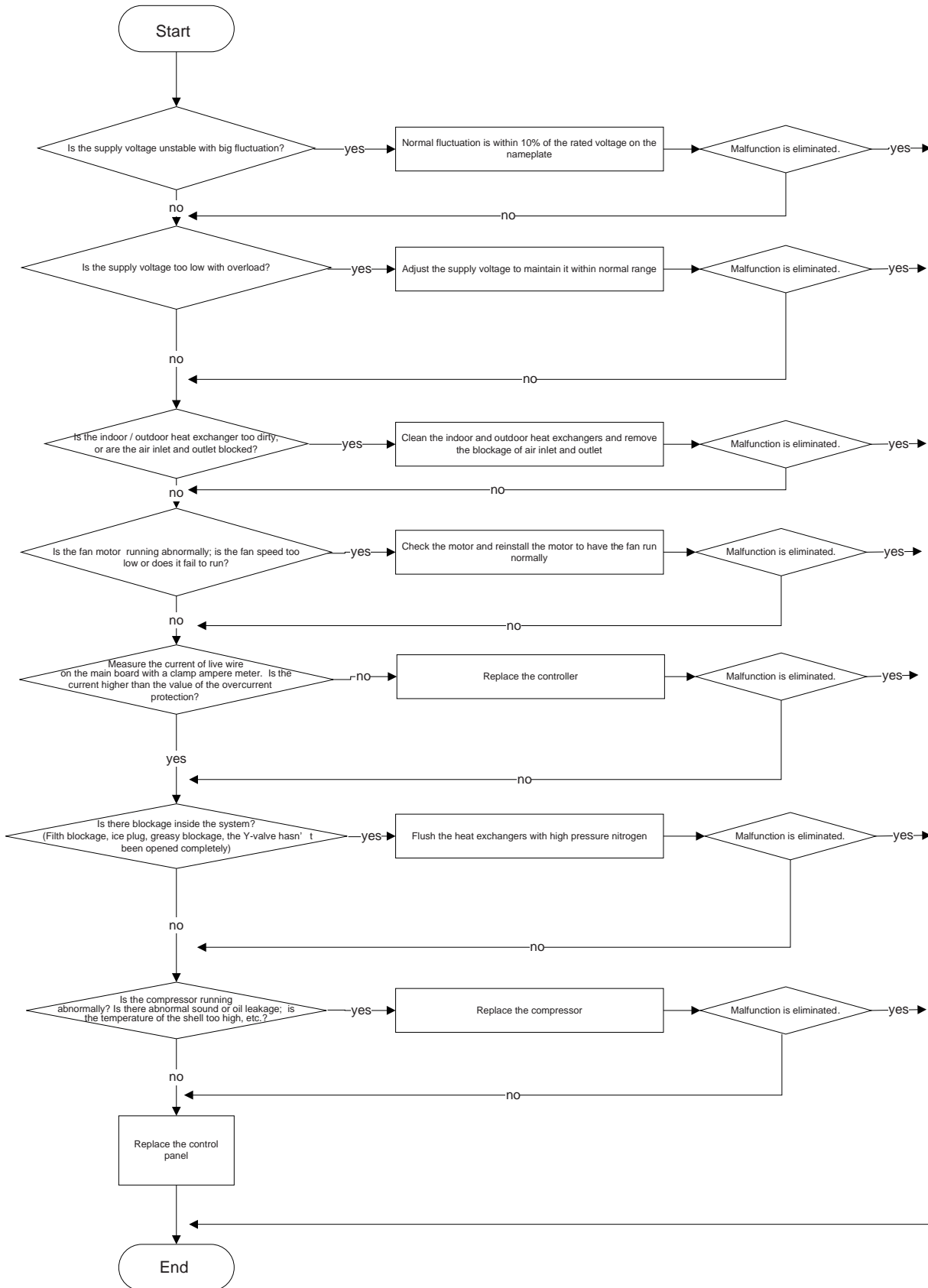

Appendix 1: Resistance Table of Ambient Temperature Sensor for Indoor and Outdoor Units(15K)

Temp(°C)	Resistance(kΩ)	Temp(°C)	Resistance(kΩ)	Temp(°C)	Resistance(kΩ)	Temp(°C)	Resistance(kΩ)
-19	138.1	20	18.75	59	3.848	98	1.071
-18	128.6	21	17.93	60	3.711	99	1.039
-17	121.6	22	17.14	61	3.579	100	1.009
-16	115	23	16.39	62	3.454	101	0.98
-15	108.7	24	15.68	63	3.333	102	0.952
-14	102.9	25	15	64	3.217	103	0.925
-13	97.4	26	14.36	65	3.105	104	0.898
-12	92.22	27	13.74	66	2.998	105	0.873
-11	87.35	28	13.16	67	2.896	106	0.848
-10	82.75	29	12.6	68	2.797	107	0.825
-9	78.43	30	12.07	69	2.702	108	0.802
-8	74.35	31	11.57	70	2.611	109	0.779
-7	70.5	32	11.09	71	2.523	110	0.758
-6	66.88	33	10.63	72	2.439	111	0.737
-5	63.46	34	10.2	73	2.358	112	0.717
-4	60.23	35	9.779	74	2.28	113	0.697
-3	57.18	36	9.382	75	2.206	114	0.678
-2	54.31	37	9.003	76	2.133	115	0.66
-1	51.59	38	8.642	77	2.064	116	0.642
0	49.02	39	8.297	78	1.997	117	0.625
1	46.6	40	7.967	79	1.933	118	0.608
2	44.31	41	7.653	80	1.871	119	0.592
3	42.14	42	7.352	81	1.811	120	0.577
4	40.09	43	7.065	82	1.754	121	0.561
5	38.15	44	6.791	83	1.699	122	0.547
6	36.32	45	6.529	84	1.645	123	0.532
7	34.58	46	6.278	85	1.594	124	0.519
8	32.94	47	6.038	86	1.544	125	0.505
9	31.38	48	5.809	87	1.497	126	0.492
10	29.9	49	5.589	88	1.451	127	0.48
11	28.51	50	5.379	89	1.408	128	0.467
12	27.18	51	5.197	90	1.363	129	0.456
13	25.92	52	4.986	91	1.322	130	0.444
14	24.73	53	4.802	92	1.282	131	0.433
15	23.6	54	4.625	93	1.244	132	0.422
16	22.53	55	4.456	94	1.207	133	0.412
17	21.51	56	4.294	95	1.171	134	0.401
18	20.54	57	4.139	96	1.136	135	0.391
19	19.63	58	3.99	97	1.103	136	0.382

Appendix 2: Resistance Table of Outdoor and Indoor Tube Temperature Sensors(20K)

Temp(°C)	Resistance(kΩ)	Temp(°C)	Resistance(kΩ)	Temp(°C)	Resistance(kΩ)	Temp(°C)	Resistance(kΩ)
-19	181.4	20	25.01	59	5.13	98	1.427
-18	171.4	21	23.9	60	4.948	99	1.386
-17	162.1	22	22.85	61	4.773	100	1.346
-16	153.3	23	21.85	62	4.605	101	1.307
-15	145	24	20.9	63	4.443	102	1.269
-14	137.2	25	20	64	4.289	103	1.233
-13	129.9	26	19.14	65	4.14	104	1.198
-12	123	27	18.13	66	3.998	105	1.164
-11	116.5	28	17.55	67	3.861	106	1.131
-10	110.3	29	16.8	68	3.729	107	1.099
-9	104.6	30	16.1	69	3.603	108	1.069
-8	99.13	31	15.43	70	3.481	109	1.039
-7	94	32	14.79	71	3.364	110	1.01
-6	89.17	33	14.18	72	3.252	111	0.983
-5	84.61	34	13.59	73	3.144	112	0.956
-4	80.31	35	13.04	74	3.04	113	0.93
-3	76.24	36	12.51	75	2.94	114	0.904
-2	72.41	37	12	76	2.844	115	0.88
-1	68.79	38	11.52	77	2.752	116	0.856
0	65.37	39	11.06	78	2.663	117	0.833
1	62.13	40	10.62	79	2.577	118	0.811
2	59.08	41	10.2	80	2.495	119	0.77
3	56.19	42	9.803	81	2.415	120	0.769
4	53.46	43	9.42	82	2.339	121	0.746
5	50.87	44	9.054	83	2.265	122	0.729
6	48.42	45	8.705	84	2.194	123	0.71
7	46.11	46	8.37	85	2.125	124	0.692
8	43.92	47	8.051	86	2.059	125	0.674
9	41.84	48	7.745	87	1.996	126	0.658
10	39.87	49	7.453	88	1.934	127	0.64
11	38.01	50	7.173	89	1.875	128	0.623
12	36.24	51	6.905	90	1.818	129	0.607
13	34.57	52	6.648	91	1.736	130	0.592
14	32.98	53	6.403	92	1.71	131	0.577
15	31.47	54	6.167	93	1.658	132	0.563
16	30.04	55	5.942	94	1.609	133	0.549
17	28.68	56	5.726	95	1.561	134	0.535
18	27.39	57	5.519	96	1.515	135	0.521
19	26.17	58	5.32	97	1.47	136	0.509

Appendix3: Resistance Table for Outdoor Discharge Temperature Sensor (50K)

Temp(°C)	Resistance(kΩ)	Temp(°C)	Resistance(kΩ)	Temp(°C)	Resistance(kΩ)	Temp(°C)	Resistance(kΩ)
-29	853.5	10	98	49	18.34	88	4.75
-28	799.8	11	93.42	50	17.65	89	4.61
-27	750	12	89.07	51	16.99	90	4.47
-26	703.8	13	84.95	52	16.36	91	4.33
-25	660.8	14	81.05	53	15.75	92	4.20
-24	620.8	15	77.35	54	15.17	93	4.08
-23	580.6	16	73.83	55	14.62	94	3.96
-22	548.9	17	70.5	56	14.09	95	3.84
-21	516.6	18	67.34	57	13.58	96	3.73
-20	486.5	19	64.33	58	13.09	97	3.62
-19	458.3	20	61.48	59	12.62	98	3.51
-18	432	21	58.77	60	12.17	99	3.41
-17	407.4	22	56.19	61	11.74	100	3.32
-16	384.5	23	53.74	62	11.32	101	3.22
-15	362.9	24	51.41	63	10.93	102	3.13
-14	342.8	25	49.19	64	10.54	103	3.04
-13	323.9	26	47.08	65	10.18	104	2.96
-12	306.2	27	45.07	66	9.83	105	2.87
-11	289.6	28	43.16	67	9.49	106	2.79
-10	274	29	41.34	68	9.17	107	2.72
-9	259.3	30	39.61	69	8.85	108	2.64
-8	245.6	31	37.96	70	8.56	109	2.57
-7	232.6	32	36.38	71	8.27	110	2.50
-6	220.5	33	34.88	72	7.99	111	2.43
-5	209	34	33.45	73	7.73	112	2.37
-4	198.3	35	32.09	74	7.47	113	2.30
-3	199.1	36	30.79	75	7.22	114	2.24
-2	178.5	37	29.54	76	7.00	115	2.18
-1	169.5	38	28.36	77	6.76	116	2.12
0	161	39	27.23	78	6.54	117	2.07
1	153	40	26.15	79	6.33	118	2.02
2	145.4	41	25.11	80	6.13	119	1.96
3	138.3	42	24.13	81	5.93	120	1.91
4	131.5	43	23.19	82	5.75	121	1.86
5	125.1	44	22.29	83	5.57	122	1.82
6	119.1	45	21.43	84	5.39	123	1.77
7	113.4	46	20.6	85	5.22	124	1.73
8	108	47	19.81	86	5.06	125	1.68
9	102.8	48	19.06	87	4.90	126	1.64

Note: The information above is for reference only.

10. Removal Procedure

10.1 Removal Procedure of Indoor Unit



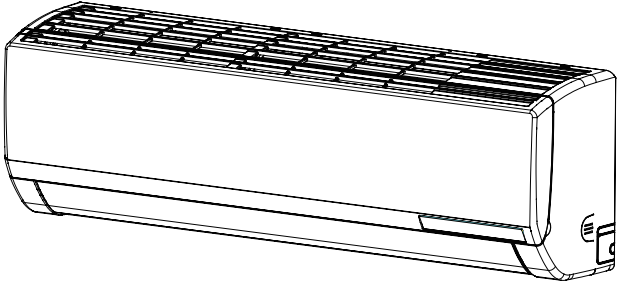
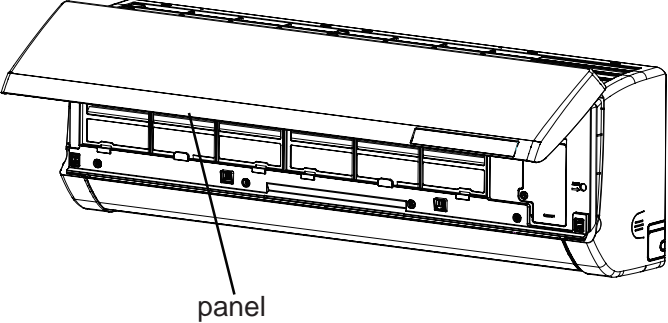
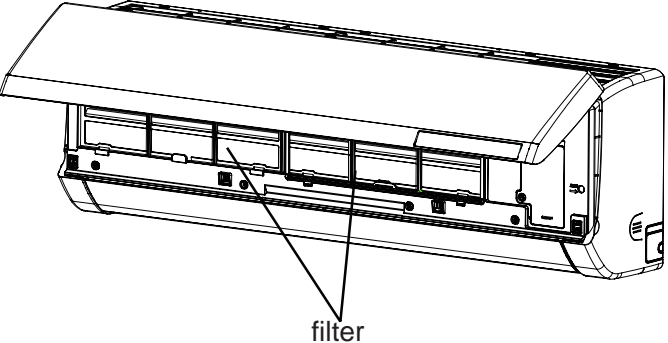
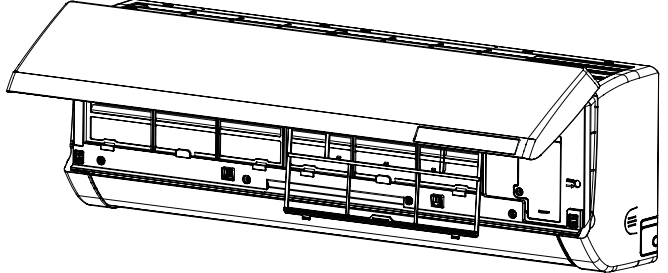

Warning Be sure to wait for a minimum of 10 minutes after turning off all power supplies before disassembly.

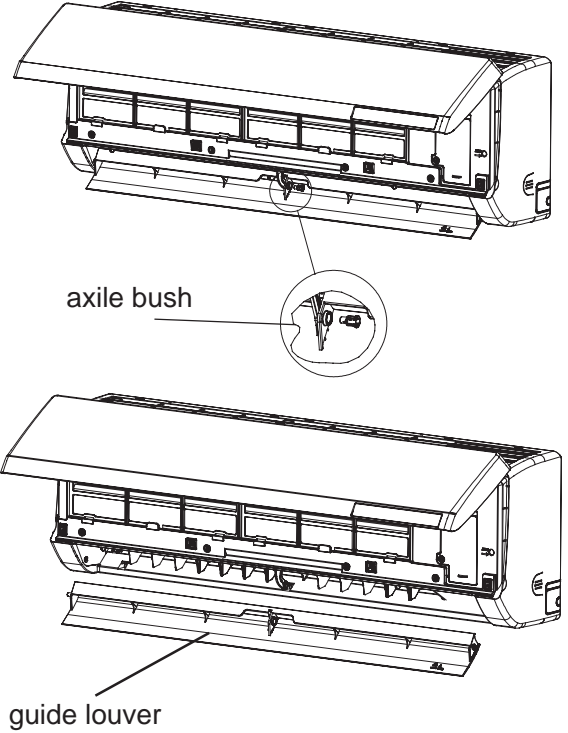
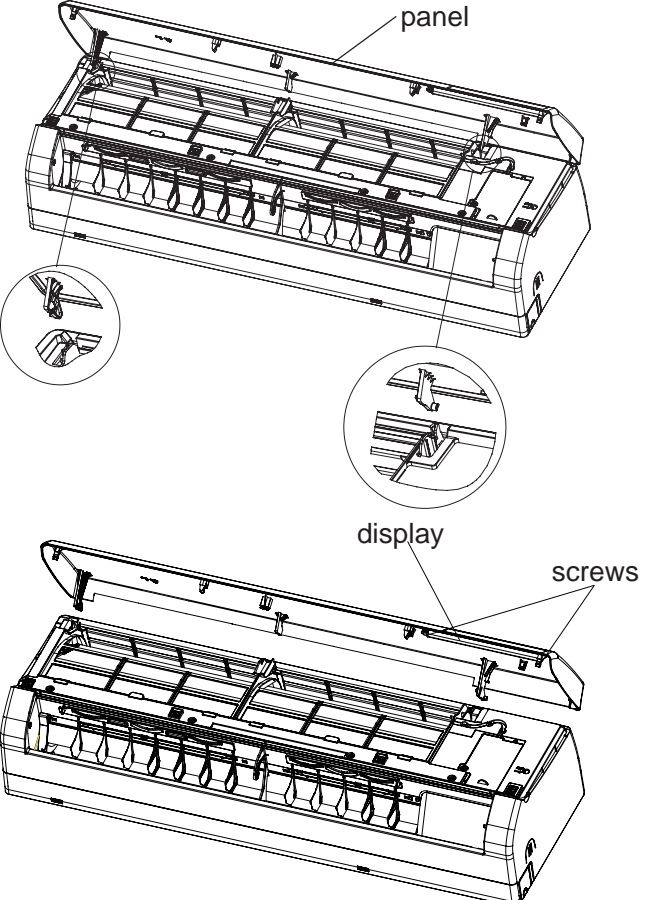
Steps	Procedure	
1. Before disassembly	Before disassembly	
2. Remove the filter	<p>1 Open the front panel.</p> <p>2 Push the filter upward and then pull it outward to remove it.</p>	 <p style="text-align: center;">panel</p>  <p style="text-align: center;">filter</p> 

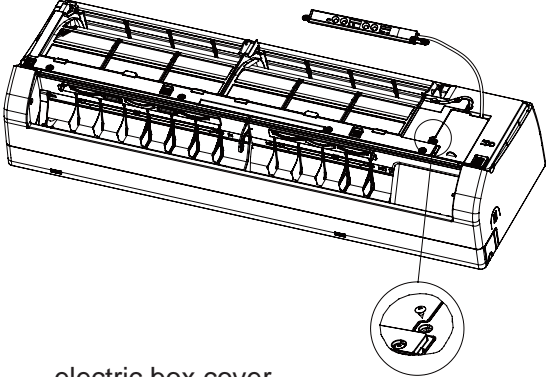
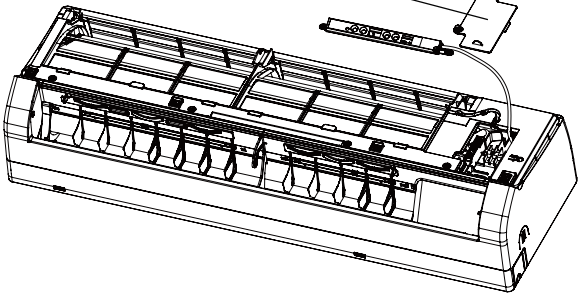
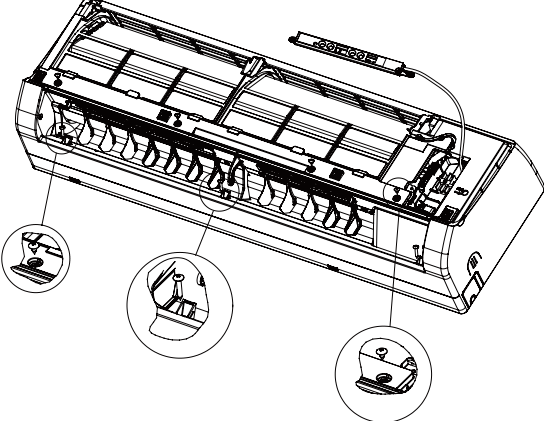
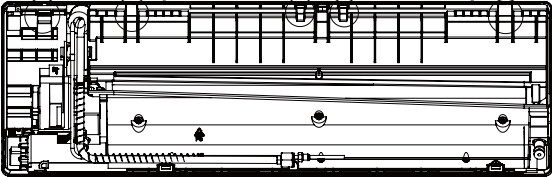
Steps	Procedure	
<p>3. Remove the guide louver</p> <p>1 Remove the axle bush on the guide louver.</p> <p>2 Pull the guide louver outward to remove it.</p>	 <p>The diagram illustrates the removal of the guide louver in two stages. In the first stage, a circular callout shows a hand using a screwdriver to pry out an axle bush from the bottom of the guide louver. The main drawing shows the device with the louver partially detached. In the second stage, the louver is shown fully pulled out and labeled 'guide louver'.</p>	
<p>4. Remove the panel</p> <p>1 Along the groove fixing front panel, slide the rotor shaft outward to remove the front panel.</p> <p>2 Loosen the screws fixing the display. Remove the panel.</p>	 <p>The diagram illustrates the removal of the front panel in two stages. In the first stage, a circular callout shows a hand sliding a rotor shaft outward along a groove. The main drawing shows the device with the front panel partially detached and labeled 'panel'. In the second stage, a circular callout shows a hand using a screwdriver to loosen screws on the display area. The main drawing shows the device with the display area removed and labeled 'display' and 'screws'.</p>	

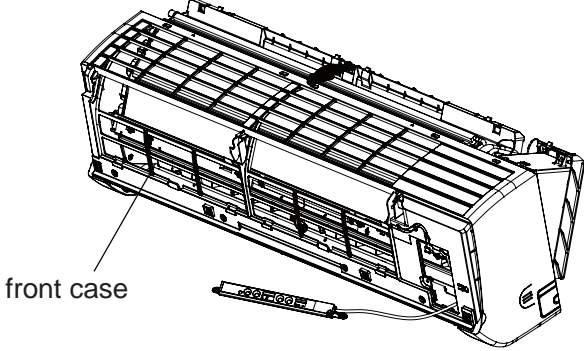
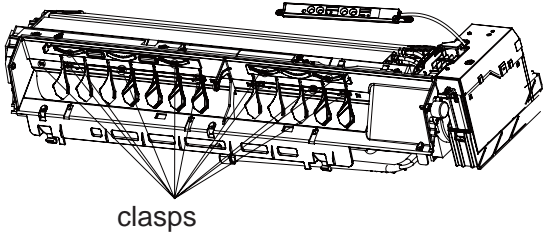
Steps	Procedure	
5. Remove the electric box cover		
1	Loosen the screw of the electric box cover.	 <p data-bbox="938 628 1161 657">electric box cover</p> 
2	Remove the electric box cover.	
6. Remove the front case		
1	Open the screw cap on the front case. Remove the screws fixing the front case.	 <p data-bbox="1122 1677 1203 1705">clasps</p> 
2	Loosen the clasps of the front case.	

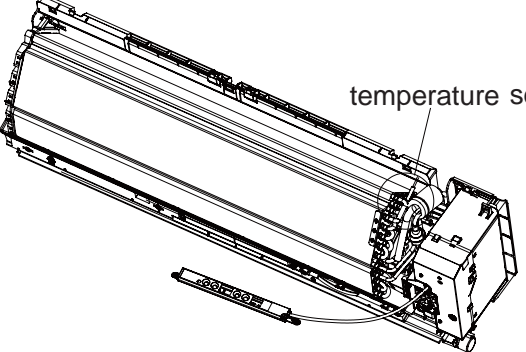
Steps	Procedure	
3	Remove the front case.	
7. Remove the vertical louver		
1	Loosen the 10 clasps connecting the vertical louver and bottom case subassembly.	
2	Remove the vertical louver.	
8. Remove the electric box subassembly		
1	Disconnect the indoor tube temperature sensor.	

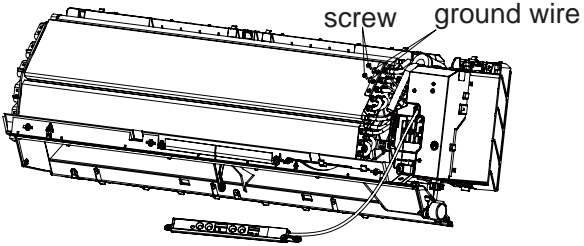
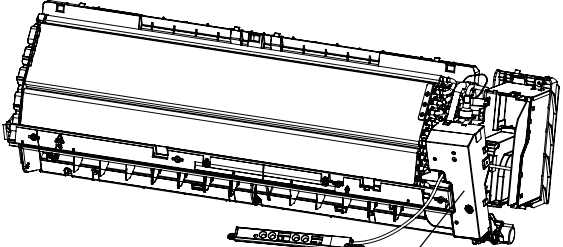
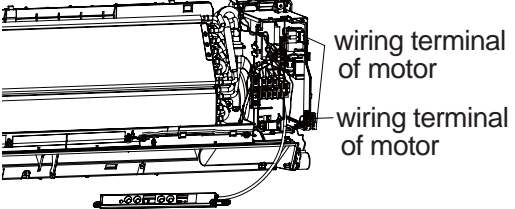
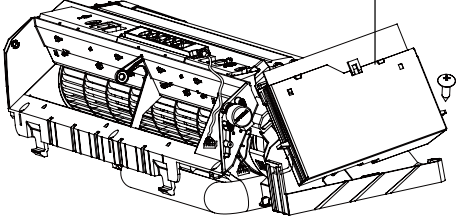
Steps	Procedure	
2	Remove the screws at the joint of the ground wire and evaporator.	 <p>This diagram shows a side view of the evaporator assembly. A screw is being removed from the joint where a ground wire is attached to the evaporator. Labels 'screw' and 'ground wire' point to the respective parts.</p>
3	Loosen the clasp at the joint of the electric box cover and the electric box. Remove the electric box cover.	 <p>This diagram shows the electric box cover being loosened from the electric box. A label 'electric box' points to the main unit.</p>
4	Disconnect the wiring terminal of the motor and step motor on the electric box.	 <p>This diagram shows a close-up of the wiring terminals on the electric box. Two labels 'wiring terminal of motor' point to the specific terminals being disconnected.</p>
5	Loosen the screws fixing the electric box and remove the electric box.	 <p>This diagram shows the electric box being loosened from the main unit. A label 'electric box' points to the box being removed.</p>

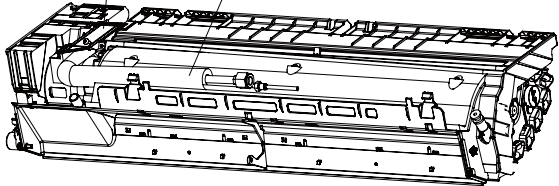
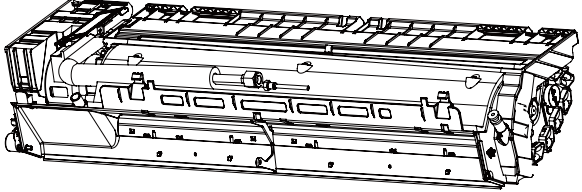
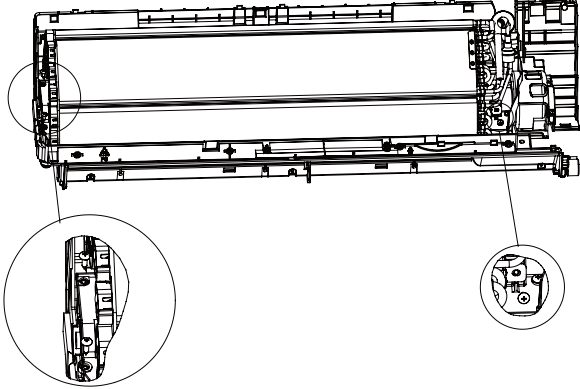
Steps	Procedure	
9. Remove press plate of connecting pipe		
1	Remove the screws of the press plate of connecting pipe.	<p data-bbox="922 351 1252 384">Pipe Clamp Auxiliary piping</p> 
2	Remove press plate of connecting pipe.	
10. Remove the evaporator		
1	Remove the screws at the joint of the evaporator and bottom case.	

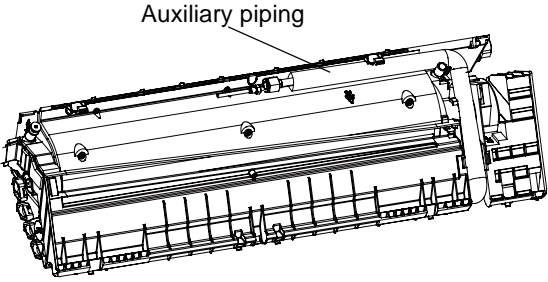
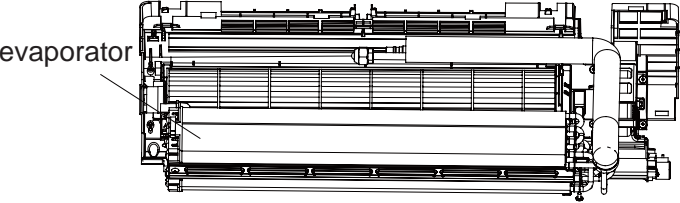
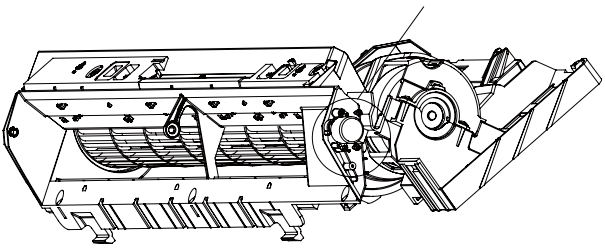
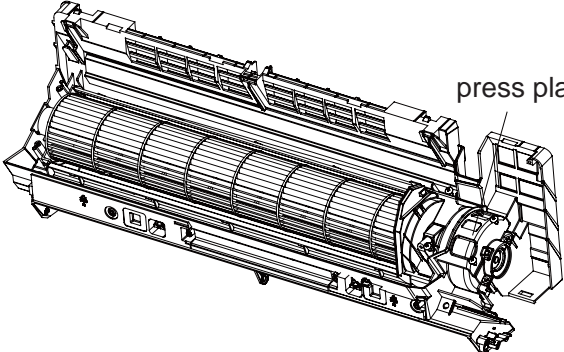
Steps	Procedure	
3	Adjust the pipe slightly to separate the connecting pipe and the evaporator.	 <p>Auxiliary piping</p>
4	Remove the evaporator.	 <p>evaporator</p>
11. Remove motor and cross flow fan		
1	Remove the screw of the step motor and remove the step motor.	 <p>step motor</p>
2	Remove the screw of the motor press plate. Remove the press plate.	 <p>press plate</p>

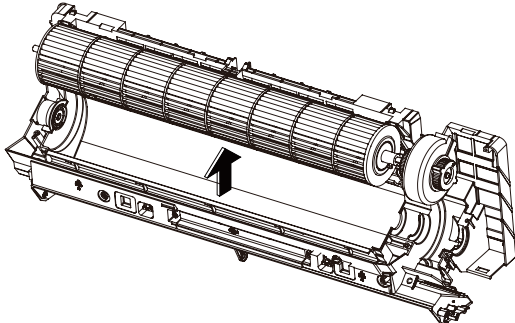
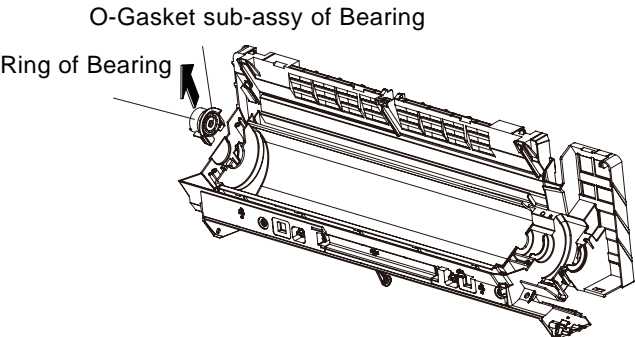
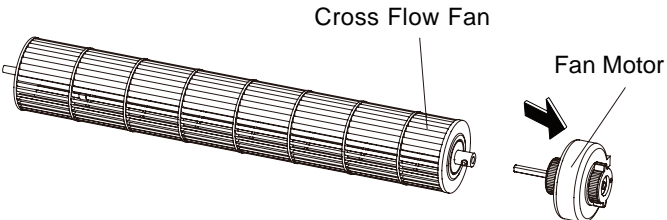
Steps	Procedure	
3	Remove the cross flow blade and motor.	
4	Remove the rubber cushion of the bearing.	 <p>O-Gasket sub-assy of Bearing</p> <p>Ring of Bearing</p>
5	Remove the screws at the joint of the cross flow blade and the motor. Take down the motor.	 <p>Cross Flow Fan</p> <p>Fan Motor</p>

10.2 Removal Procedure of Outdoor Unit

 **Warning** Be sure to wait for a minimum of 10 minutes after turning off all power supplies before disassembly.

GWH18PD-K3NNA1A/O

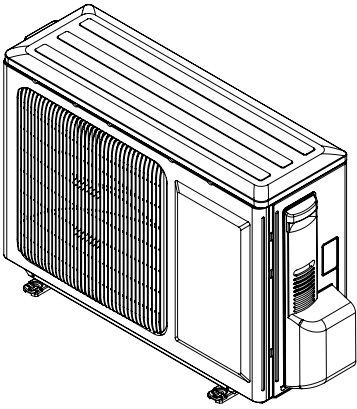
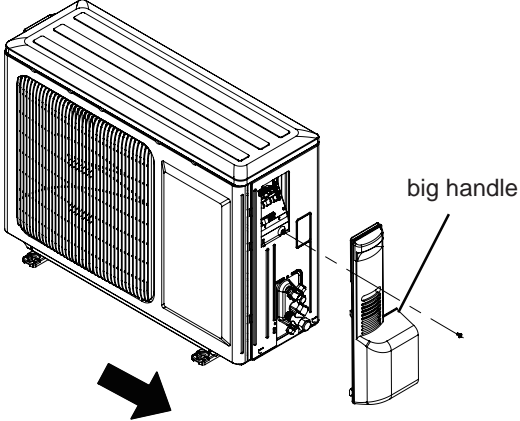
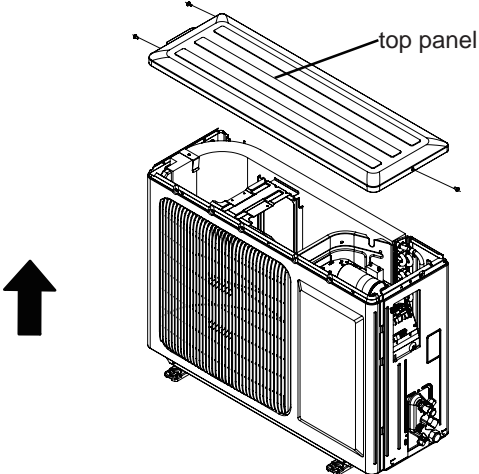
Steps	Procedure
<p>1. Before disassembly</p>	
<p>2. Remove big handle</p>	<p>Remove the connection screw fixing the big handle and then remove the handle.</p> 
<p>3. Remove top cover plate</p>	<p>Remove connection screws connecting the top panel with the front panel and the right side plate, and then remove the top panel.</p> 

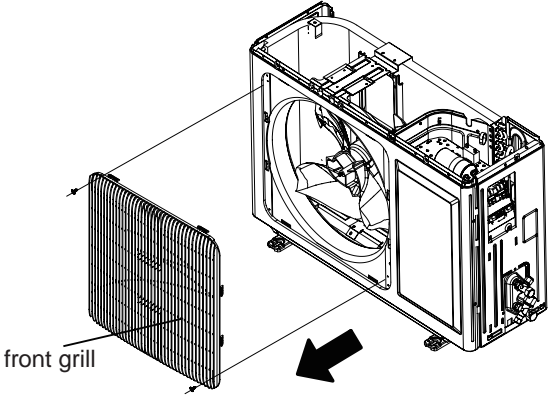
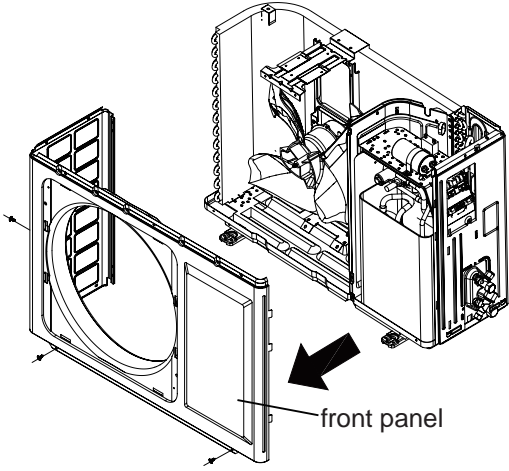
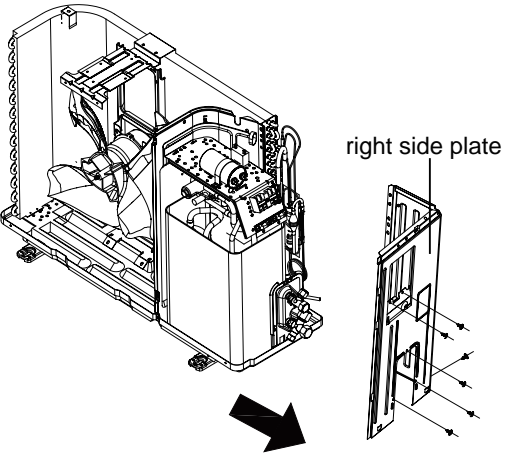
Steps	Procedure	
<p data-bbox="159 248 440 281">4. Remove front grille</p>	<p data-bbox="220 445 768 515">Remove connection screws between the front grille and the front panel. Then remove the front grille.</p>	
<p data-bbox="159 799 448 832">5. Remove front panel</p>	<p data-bbox="220 956 748 1050">Remove connection screws connecting the front panel with the chassis and the motor support and then remove the front panel.</p>	
<p data-bbox="159 1356 496 1389">6. Remove right side plate</p>	<p data-bbox="220 1574 740 1668">Remove connection screws connecting the right side plate with the valve support and the electric box. Then remove the right side plate.</p>	

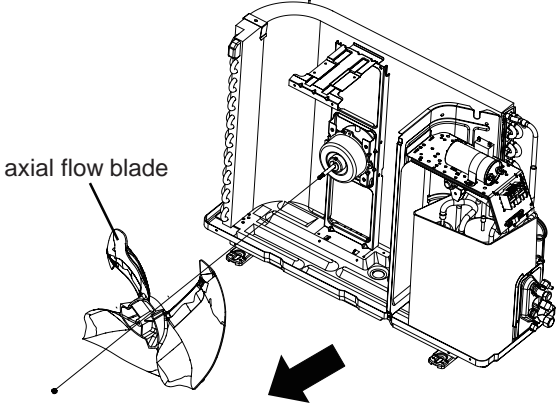
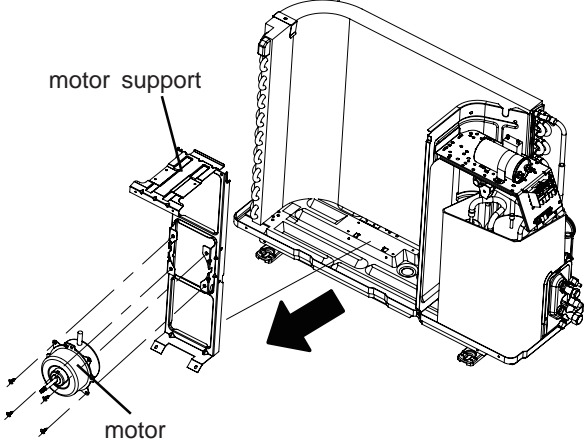
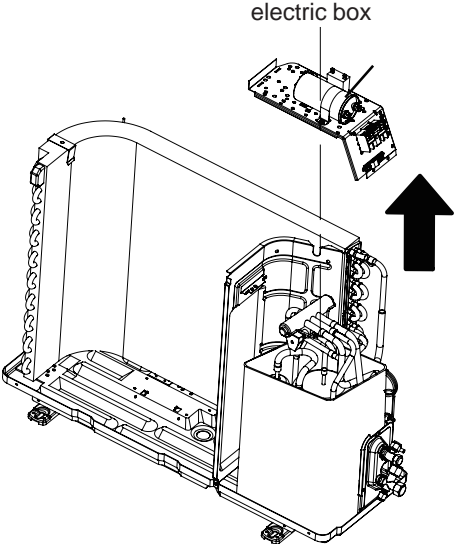
Steps	Procedure
<p>7. Remove axial flow blade</p>	<p>Remove the nut on the blade and then remove the axial flow blade.</p>  <p>axial flow blade</p>
<p>8. Remove motor and motor support</p>	<p>Remove the 4 tapping screws fixing the motor and disconnect the leading wire insert of the motor. Then remove the motor. Remove the 2 tapping screws fixing the motor support and lift the motor support to remove it.</p>  <p>motor support</p> <p>motor</p>
<p>9. Remove electric box</p>	<p>Remove screws fixing the electric box subassembly; loosen the wire bundle and unplug the wiring terminals. Then lift the electric box to remove it.</p>  <p>electric box</p>

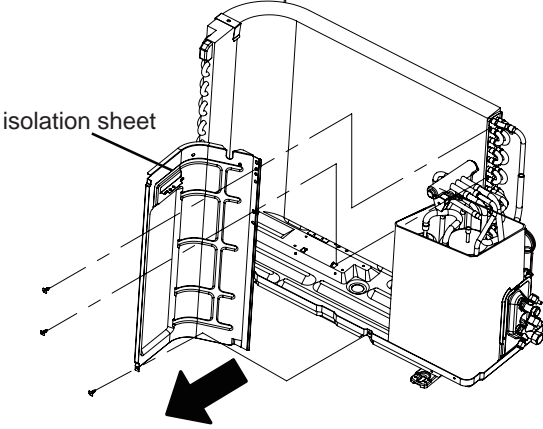
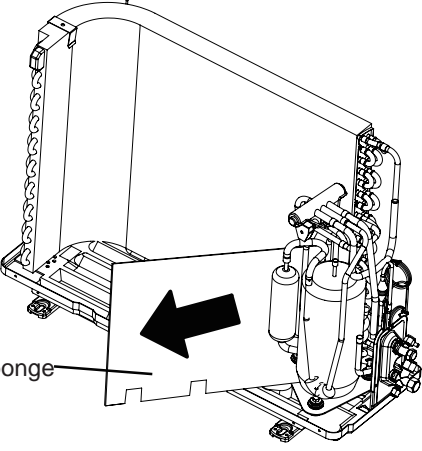
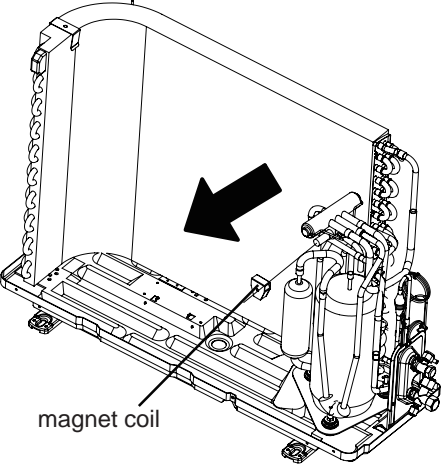
Steps	Procedure
10. Remove isolation sheet	<p data-bbox="220 497 764 554">Remove the 3 screws fixing the isolation sheet and then remove the isolation sheet.</p>  <p data-bbox="881 410 1036 438">isolation sheet</p>
11. Remove soundproof sponge	<p data-bbox="220 1028 711 1085">Remove the soundproof sponge wrapping the compressor.</p>  <p data-bbox="841 1214 1057 1242">soundproof sponge</p>
12. Remove magnet coil	<p data-bbox="220 1596 756 1653">Remove the screw fixing the magnet coil and then remove the coil.</p>  <p data-bbox="1008 1902 1133 1930">magnet coil</p>

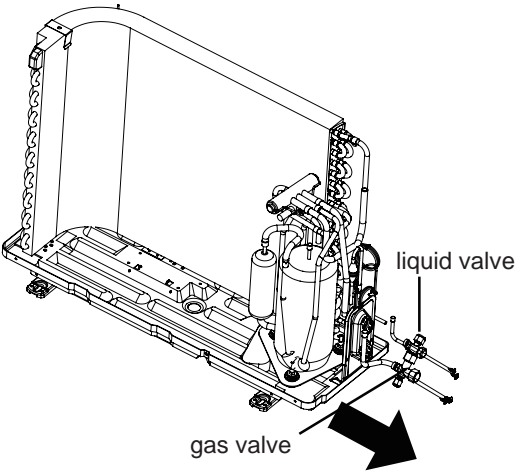
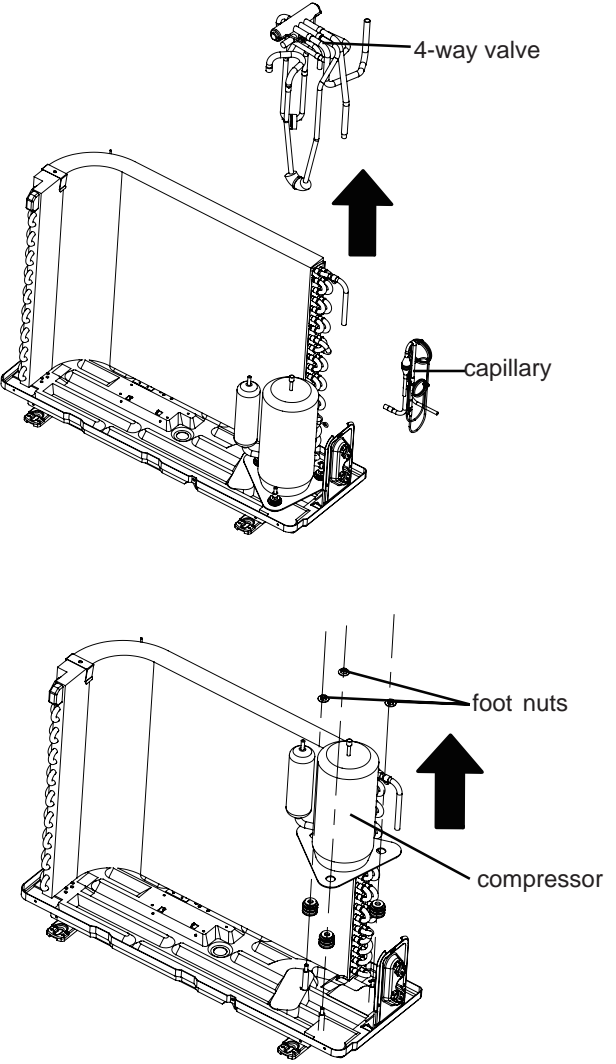
Steps	Procedure	
	<p>13. Remove liquid valve and gas valve</p> <p>Unsolder the welding joint connecting the capillary, valves and the outlet pipe of condenser to remove the capillary. Do not block the capillary with welding slag during unsoldering.</p> <p>Remove the 2 screws fixing the gas valve and unsolder the welding joint between the gas valve and the air-return pipe to remove the gas valve. (NOTE: Discharge the refrigerant completely before unsoldering; when unsoldering, wrap the gas valve with a wet cloth completely to avoid damage to the valve caused by high temperature).</p> <p>Remove the 2 screws fixing the liquid valve and unsolder the welding joint connecting the liquid valve to the Y-type pipe to remove the liquid valve.</p>	
<p>a</p> <p>b</p>	<p>14. Remove compressor</p> <p>Unsolder pipes connecting with compressor.</p> <p>Remove the 3 foot nuts on the compressor and then remove the compressor.</p>	

Warning Be sure to wait for a minimum of 10 minutes after turning off all power supplies before disassembly.

GWH24ND-K3NNB1A/O

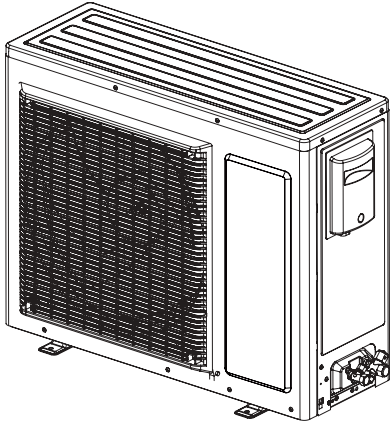
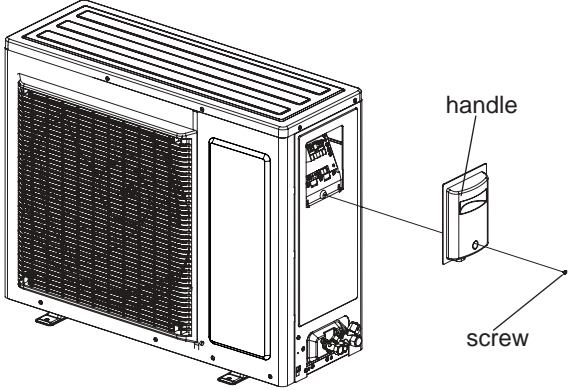
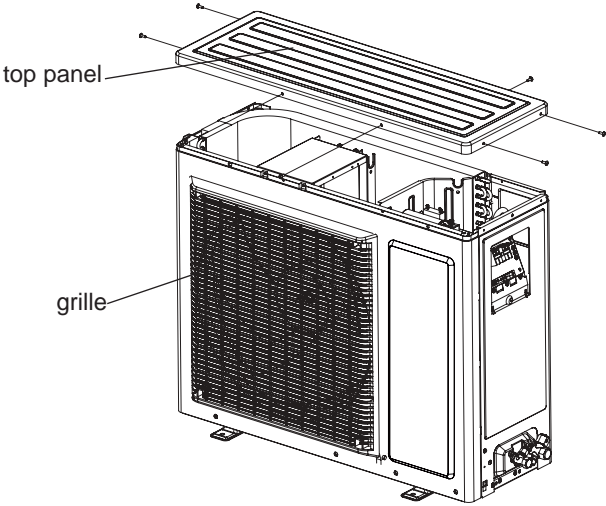
Steps	Procedure
1. Before disassembly	
2. Remove handle	<p data-bbox="215 1050 678 1122">Remove the screw fixing the handle and then remove the handle.</p> 
3. Remove top panel and grille	<p data-bbox="220 1450 683 1563">Remove screws fixing the top panel and the grille respectively, and then remove the top panel and the grille.</p> 

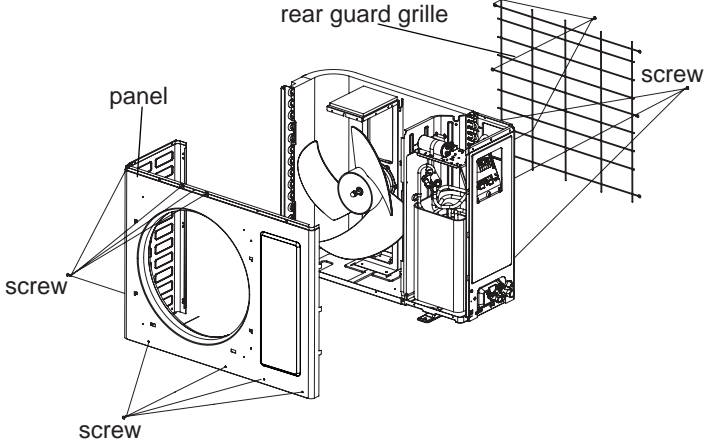
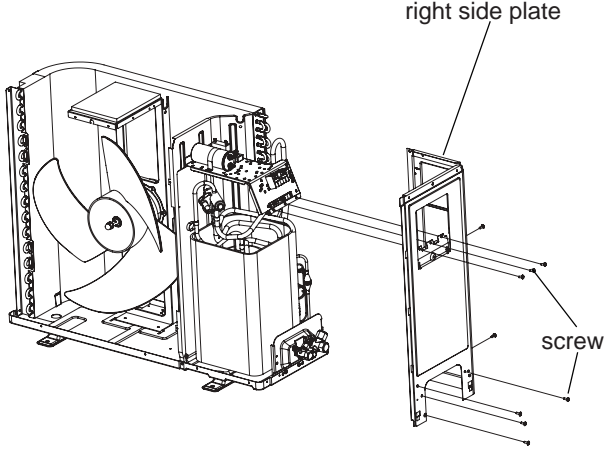
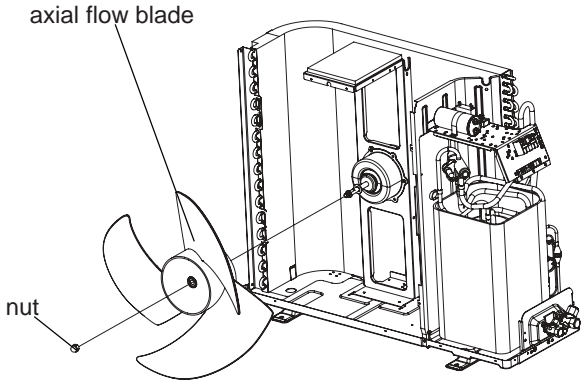
Steps	Procedure
<p>4. Remove front panel and rear guard grille</p>	<p>Remove screws fixing the front panel and the rear guard grille respectively, and then remove the front panel and the rear guard grille.</p> 
<p>5. Remove right side plate</p>	<p>Remove screws connecting the front panel with the chassis and the motor support, and then remove the right side plate.</p> 
<p>6. Remove axial flow blade</p>	<p>Remove nut fixing the blade and then remove the blade.</p> 

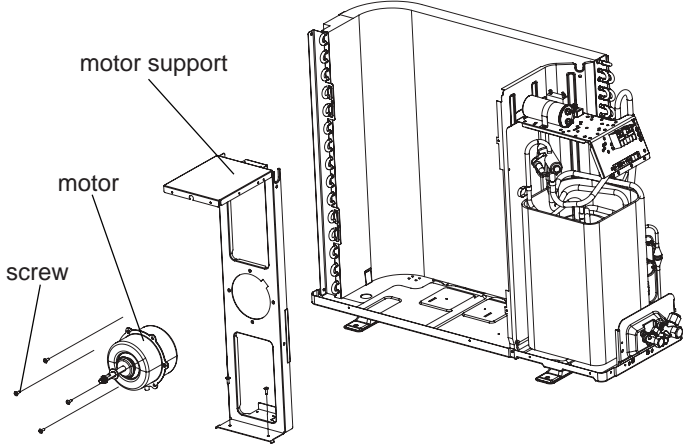
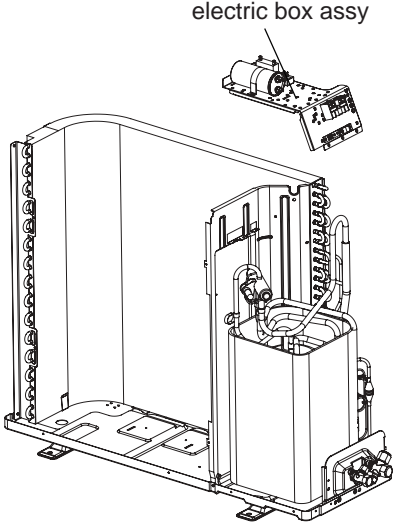
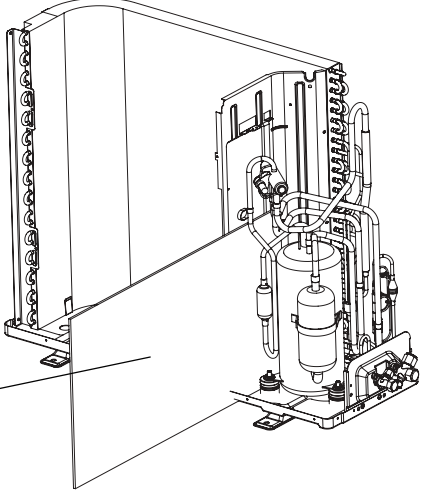
Steps	Procedure	
7. Remove motor and motor support	<p>Remove screws on the motor and the motor support, and then remove the motor and the motor support.</p>	 <p>motor support</p> <p>motor</p> <p>screw</p>
8. Remove electric box	<p>Remove the 2 screws fixing the electric box; loosen the wire bundle; pull out the wiring terminals and then pull electric box upwards to remove it.</p>	 <p>electric box assy</p>
9. Remove soundproof sponge	<p>Remove the soundproof sponge wrapping the compressor.</p>	 <p>soundproof sponge</p>

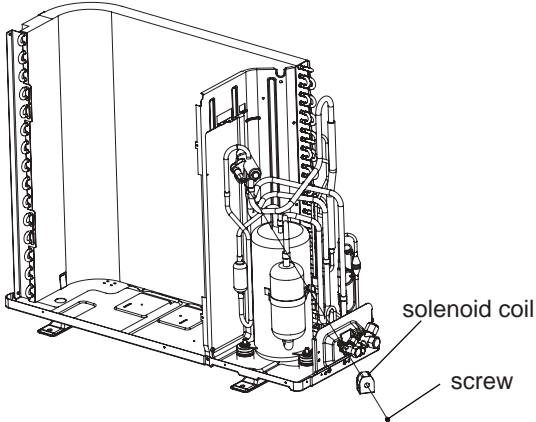
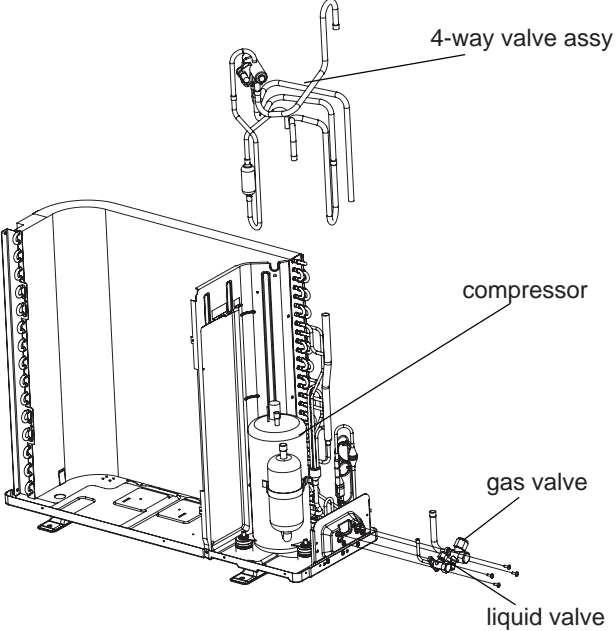
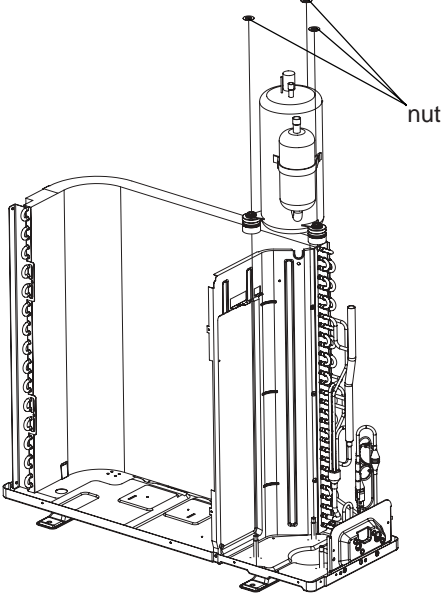
Steps	Procedure
10. Remove solenoid coil	<p data-bbox="207 449 670 519">Remove the screw on the solenoid coil, and then remove the solenoid coil.</p> 
11. Remove compressor	<p data-bbox="134 1083 691 1360">1 Unsolder the pipes (including the soldering joint among the 4-way valve, the compressor, the condenser, the gas valve and the liquid valve) connected to the compressor at first. (NOTE: Before unsoldering the joints, discharge the refrigerant completely)</p>  <p data-bbox="134 1710 696 1821">2 Remove the 3 foot nuts fixing the compressor with wrench, and then remove the compressor.</p> 

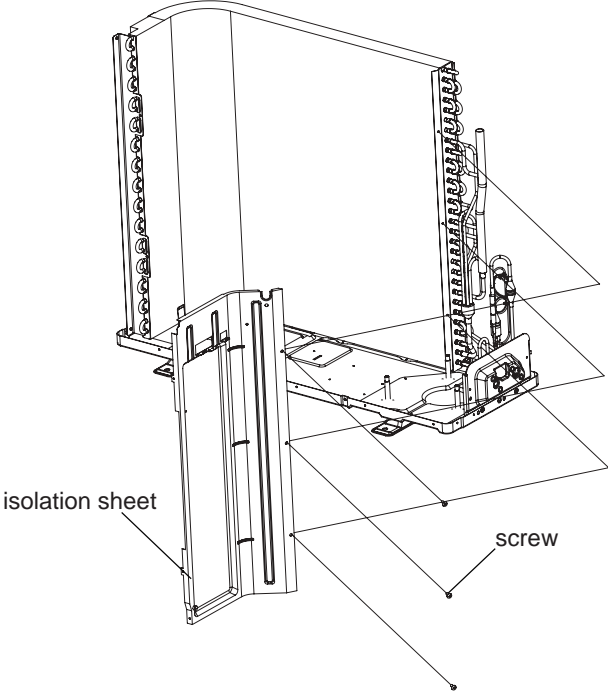
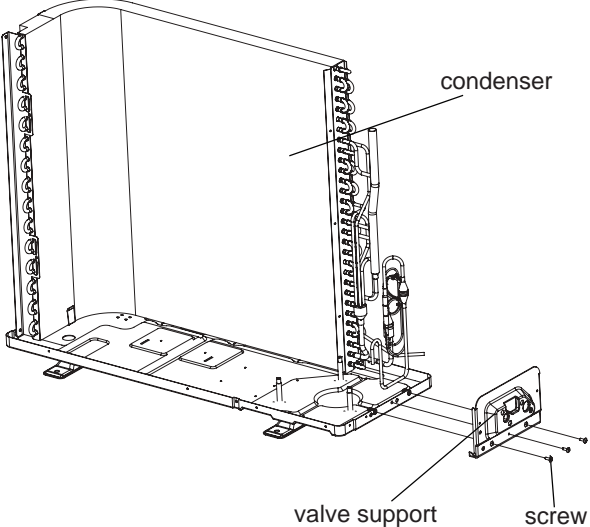
Steps	Procedure
12. Remove isolation sheet	<p data-bbox="212 511 675 576">Remove the 3 screws fixing the isolation sheet and then remove the isolation sheet.</p>  <p data-bbox="800 821 959 847">isolation sheet</p> <p data-bbox="1295 860 1360 886">screw</p>
13. Remove valve support and condenser	<p data-bbox="212 1284 675 1472">Remove screws fixing the valve support and then remove the valve support; Remove the screw fixing the condenser and then pull the condenser upwards to remove it.</p>  <p data-bbox="1305 1284 1422 1310">condenser</p> <p data-bbox="1159 1716 1305 1742">valve support</p> <p data-bbox="1390 1716 1455 1742">screw</p>

JF00301351

GREE ELECTRIC APPLIANCES, INC. OF ZHUHAI

Add: West Jinji Rd, Qianshan, Zhuhai, Guangdong, China, 519070

Tel: (+86-756) 8522218 Fax: (+86-756) 8669426

E-mail: gree@gree.com.cn www.gree.com

For continuous improvement in the products, Gree reserves the right to modify the product specification and appearance in this manual without notice and without incurring any obligations.