



AC500

For doors in industrial environments

- Recommended installation height 5 m*
- Horizontal and vertical mounting
- Lengths: 1 and 1,5 m

Application

AC500 is a stable air curtain intended for use on high industrial and warehouse doors. The air curtain effectively prevents energy losses and drafts through the open door and gives excellent heating comfort. The working environment is further improved by the air curtain preventing exhaust emissions, dust and insects from entering the premises.

Design

AC500 is a narrow and tall, splash proof air curtain equipped with a honeycomb grille. The air is blown out at high pressure through the grille, which results in a powerful and well defined laminar airflow.



Optimized airflow with Thermozone technology.

Air velocity profile

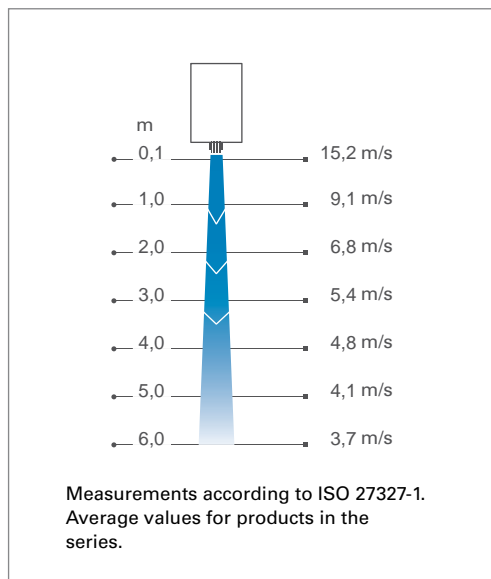

Product specifications

- Diagonal fans combine high pressure with high air flow.
- The unit or air directors can be angled to achieve optimal effect.
- Honeycomb grille ensures a powerful and well defined air flow.
- Protection class: IP24.
- Can also be used in the vertical position.
- Wall brackets included.
- Corrosion proof housing made of hot zinc-plate and powder enamelled steel panels. Colour: white, RAL 9016, NCS S 0500-N.

Technical specifications

✿ Ambient, no heat - AC500

Type	Output [kW]	Airflow [m³/h]	Sound level* [dB(A)]	Voltage motor [V]	Amperage motor [A]	Length [mm]	Weight [kg]
AC501	0	5200	63	400V3~	1,8	1030	65
AC502	0	7700	65	400V3~	2,7	1550	93

*) Conditions: Distance to the unit 5 metres. Directional factor: 2. Equivalent absorption area: 200 m².

Protection class: IP24.
CE compliant.

Dimensions

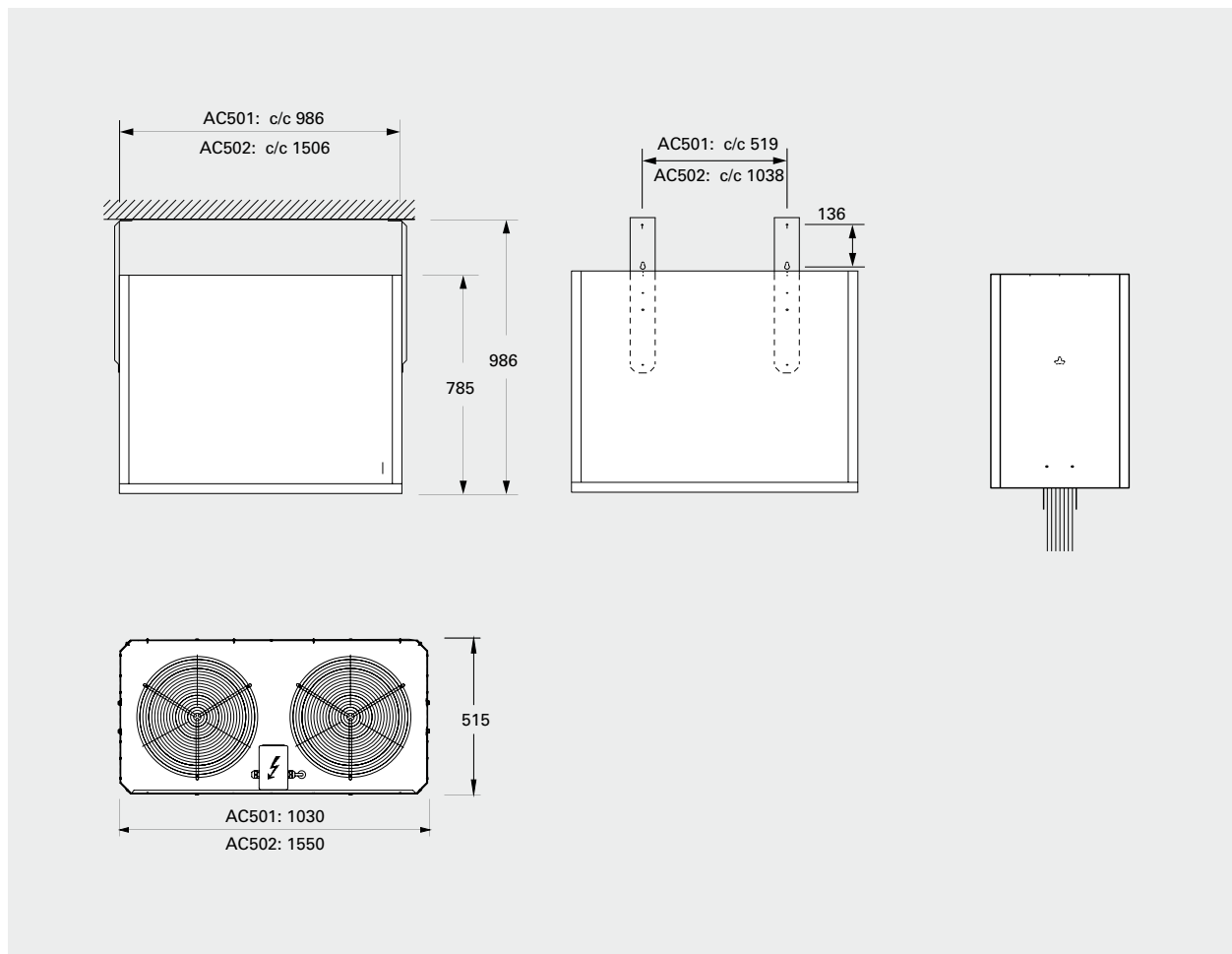

Mounting and connection

Mounting

The air curtain is installed horizontally with the supply air grille facing downwards as close to the door as possible. The air curtain is mounted on a beam, wall or in the ceiling using the mounting brackets supplied. The unit or air directors can be tilted for optimum output. For the protection of wider doorways, several units can be mounted next to each other.

Connection

Control (400V3~) is connected to the terminal block in the junction box on top of the unit.

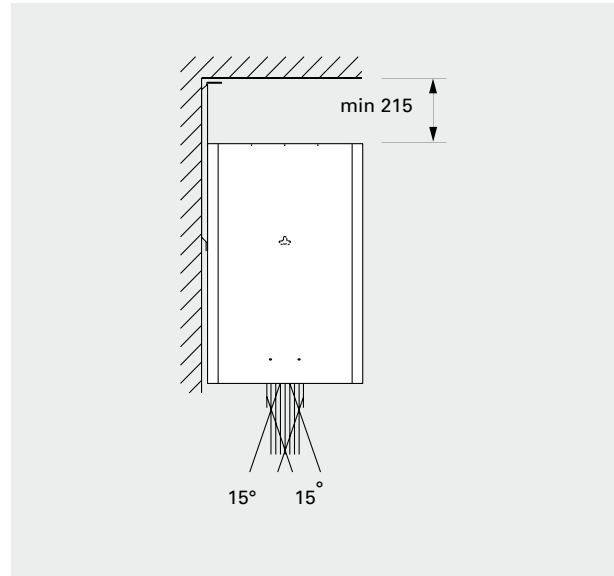

Minimum distances

Control options

Level 1

Airflow is set manually. The position limit switch regulates the airflow on/off.

Control kit:

- RTRD7, RTRD14, 5-step fan speed control
- AGB304, position limit switch.

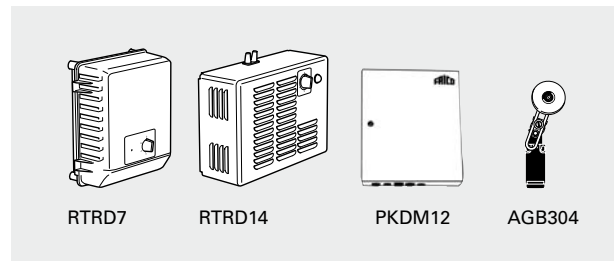

Level 2

Suitable speed is set for open/closed doors respectively. A position limit switch can be used to regulate on/off or high/low speed.

Control kit:

- PKDM12, stepless fan speed control.
- AGB304, position limit switch.

Type	Description
RTRD7	5-step fan speed control, Max 7 A
RTRD14	5-step fan speed control, Max 14 A
PKDM12	Stepless fan speed control, high/low speed, IP54
AGB304	Position limit switch, IP44

Wiring diagrams

Level 1

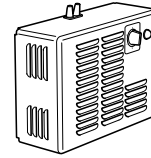
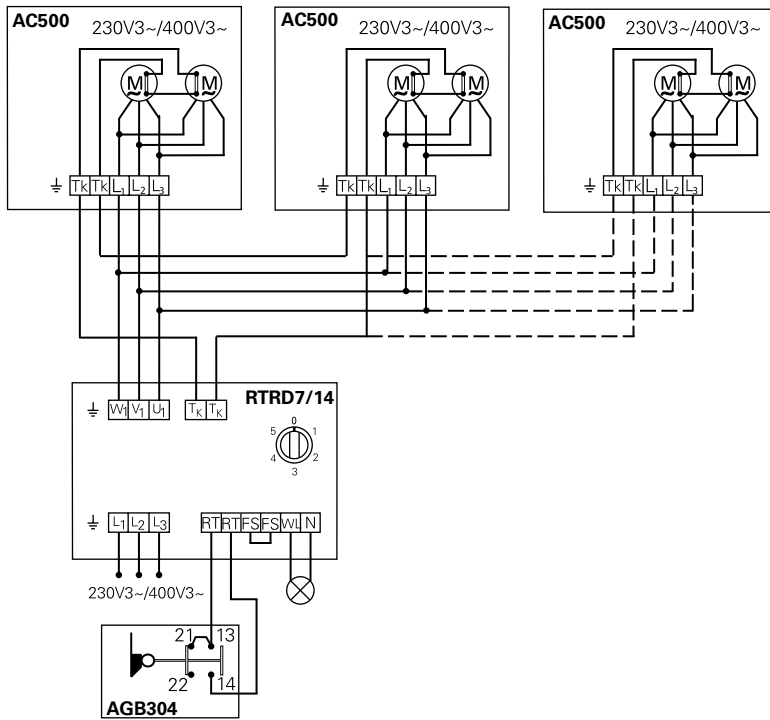

RTRD14,
5-step fan speed control



RTRD7,
5-step fan speed control



AGB304,
position limit switch

Level 2

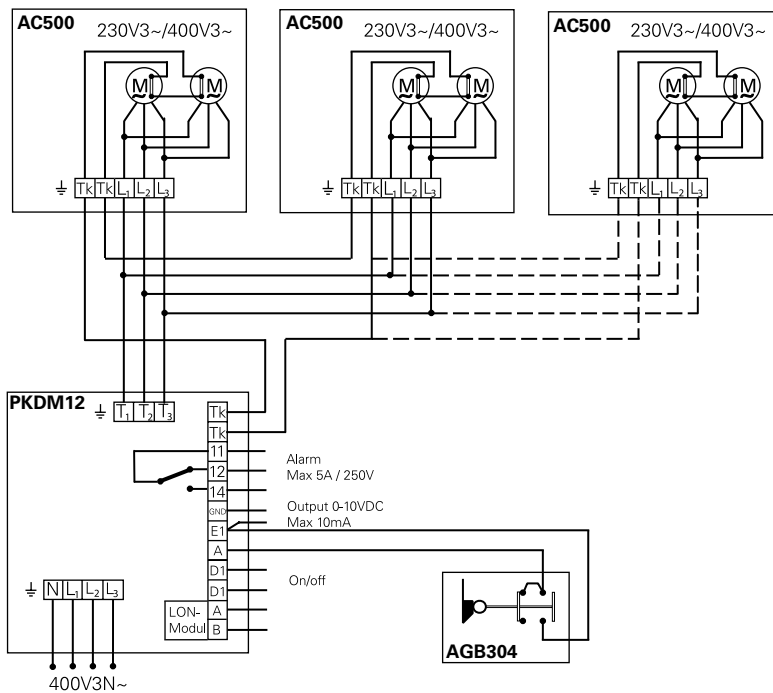

PKDM12,
stepless fan speed control



AGB304,
position limit switch