

# FlowCon Green



*100% Authority  
Pressure Independent Control Valves*

**FLOW**

# FlowCon Green

## Pressure Independent Control Valves



The FlowCon Green insert is designed as a 3-in-1 solution combining a full stroke modulation control valve, an automatic balancing valve and a differential pressure control valve. This new insert includes an innovative self-adjustment feature, which enables each valve continuously to self-balance. This ensures delivery of precisely the flow rate required by each terminal unit, independent of pressure fluctuations in the hydronic system. Each FlowCon Green insert can also be adjusted to set an accurate maximum flow rate limit to each circuit without stroke limitation.

The FlowCon Green insert can be used in several different applications within heating or cooling such as fan-coil units, air-handler units and other terminal units - wherever dynamic balancing and fully accurate temperature control are required, the FlowCon Green insert will be the ideal choice. It will be the easy solution to both designers, installers and end-users due to its user-friendly complete solution in one body and with one insert.

### Valve Choice

The FlowCon Green insert can be used with the following FlowCon valves:

- FlowCon A (1/2" / 3/4" / 1")
- FlowCon AB (1/2" / 3/4" / 1" / 1 1/4")
- FlowCon ABV1 (1/2" / 3/4" / 1")
- FlowCon ABV2 (1" / 1 1/4" / 1 1/2")

### 100% Valve Authority

The FlowCon Green is a 100% authority pressure independent flow control valve which instantaneously self-balance at all points of operation, even when there is variance in pressure differential.

**100% authority pressure independent**

As long as the pressure differential across the valve is within the operating range, the Cv of the valve is variable, being continuously regulated to keep the control

valve in constant authority. The FlowCon Green insert will in other words always use full stroke of the spindle offering the 100% authority for any of its 41 maximum flow settings.

### Features and Benefits

- **3-in-1 combi valve**, modulating control valve, dynamic flow limiter and differential pressure control valve in one body.
- **Differential pressure independent.**
- **Full stroke modulation** at any desing flow.
- **100% authority** for any of the insert's flow setting.
- **Automatic system balancing**, the correct flow rate for each circuit is achieved automatically.
- **Dynamic balancing**, the correct flow rate is maintained as each valve continuously compensates for pressure fluctuations in the system.
- **Field adjustable**, flow rate can be changed on demand without removing the insert from the valve body.
- **Elimination of branch or "partner" balancing valves** which results in fewer total valves used in each project.
- **Easily accessible insert** for flow rate adjustment or maintenance.
- **Accuracy:** Greatest of either  $\pm 10\%$  of controlled flow rate or  $\pm 5\%$  of maximum flow rate.
- **Up to 41 different flow curves** in one and the same insert.
- **Choice of actuator**, electrical actuators: 0(2)-10V modulating, 3-point floating or 2-position, or thermal actuators: 0-10V modulating or ON/OFF.
- **Built-in isolation ball valve** (FlowCon ABV).
- **Pressure/temperature measurement plugs** available for verifying operating differential pressure or checking  $\Delta T$  across the coil (FlowCon AB / ABV).
- **Double union end connection** for ease of installation and wide selection of end fittings (FlowCon ABV) or **fixed end** female-by-female threaded (FlowCon A / AB).



FlowCon Green									
Insert: 20mm, 3/4"						Insert: 40mm, 1 1/2"			Setting
16-200 kPaD · 2.3-29 psid			30-400 kPaD · 4.4-58 psid			16-400 kPaD* · 2.3-58 psid*			
Green.0 (green o-ring)			Green.1 (black o-ring)			Green.2 (black o-ring)			
I/sec	I/hr	GPM	I/sec	I/hr	GPM	I/sec	I/hr	GPM	
0.0089	32.0	0.141	0.0178	64	0.282	0.240	865	3.81	1.0
0.0211	75.8	0.334	0.0393	142	0.624	0.282	1010	4.46	1.1
0.0323	116	0.511	0.0580	209	0.920	0.322	1160	5.10	1.2
0.0426	153	0.675	0.0743	268	1.180	0.361	1300	5.72	1.3
0.0521	188	0.826	0.0887	319	1.41	0.399	1430	6.32	1.4
0.0610	220	0.967	0.102	366	1.61	0.435	1570	6.90	1.5
0.0693	250	1.10	0.113	408	1.80	0.471	1700	7.47	1.6
0.0771	278	1.22	0.124	446	1.96	0.506	1820	8.02	1.7
0.0844	304	1.34	0.134	482	2.12	0.540	1940	8.56	1.8
0.0913	329	1.45	0.143	516	2.27	0.573	2060	9.08	1.9
0.0978	352	1.55	0.152	549	2.42	0.605	2180	9.59	2.0
0.104	374	1.65	0.161	580	2.56	0.636	2290	10.1	2.1
0.110	396	1.74	0.170	611	2.69	0.667	2400	10.6	2.2
0.115	416	1.83	0.178	641	2.82	0.696	2510	11.0	2.3
0.121	435	1.92	0.186	671	2.95	0.725	2610	11.5	2.4
0.126	453	2.00	0.194	700	3.08	0.753	2710	11.9	2.5
0.131	471	2.07	0.202	728	3.21	0.780	2810	12.4	2.6
0.136	488	2.15	0.210	756	3.33	0.807	2900	12.8	2.7
0.140	504	2.22	0.218	783	3.45	0.832	3000	13.2	2.8
0.144	520	2.29	0.225	810	3.56	0.858	3090	13.6	2.9
0.149	535	2.35	0.232	835	3.68	0.882	3180	14.0	3.0
0.153	549	2.42	0.239	860	3.79	0.906	3260	14.4	3.1
0.156	563	2.48	0.245	883	3.89	0.930	3350	14.7	3.2
0.160	577	2.54	0.252	906	3.99	0.953	3430	15.1	3.3
0.164	590	2.60	0.257	927	4.08	0.975	3510	15.5	3.4
0.167	602	2.65	0.263	946	4.17	0.997	3590	15.8	3.5
0.171	614	2.70	0.268	965	4.25	1.02	3670	16.1	3.6
0.174	626	2.76	0.273	982	4.32	1.04	3740	16.5	3.7
0.177	637	2.81	0.277	998	4.39	1.06	3820	16.8	3.8
0.180	649	2.86	0.281	1010	4.46	1.08	3890	17.1	3.9
0.183	659	2.90	0.285	1020	4.51	1.10	3960	17.4	4.0
0.186	670	2.95	0.288	1040	4.57	1.12	4030	17.7	4.1
0.189	681	3.00	0.291	1050	4.61	1.14	4100	18.1	4.2
0.192	691	3.04	0.294	1060	4.66	1.16	4170	18.4	4.3
0.195	701	3.09	0.296	1070	4.70	1.18	4240	18.7	4.4
0.197	711	3.13	0.299	1080	4.73	1.20	4300	19.0	4.5
0.200	721	3.17	0.301	1080	4.77	1.21	4370	19.2	4.6
0.203	730	3.22	0.303	1090	4.80	1.23	4440	19.5	4.7
0.205	740	3.26	0.305	1100	4.83	1.25	4500	19.8	4.8
0.208	749	3.30	0.307	1100	4.86	1.27	4570	20.1	4.9
0.210	757	3.33	0.308	1110	4.89	1.29	4630	20.4	5.0

Accuracy: Greatest of either ±10% of controlled flow rate or ±5% of maximum flow rate.  
\*at setting 2.6.

### Principle of Operation

On closer examination of the inner workings of the FlowCon Green, the function is best described as 2 valves in 1. The second valve (V2) regulates the pressure differential across the first valve (V1) by means of a rolling diaphragm element counteracted by a spring. The first valve is a calibrated variable orifice device adjusted by the actuator (similar to a standard modulating control valve).

The diaphragm reacts to the system and regulates the pressure differential across the actuated control valve orifice to maintain its flow rate.

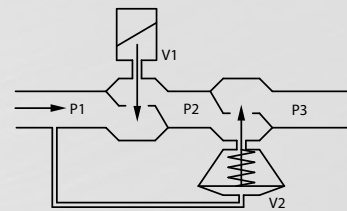

When pre-setting the maximum flow rate, the inlet orifice is changed in size sideways which does not interfere with the length of the stroke. When modulating, the orifice areas are affected by the actuator using the full stroke which results in the fact that the orifice area is changed in size in a vertical movement.

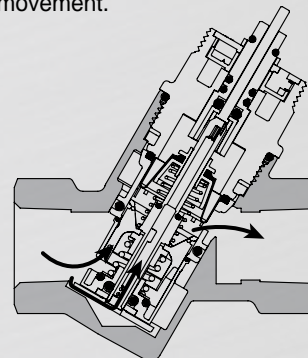

### Hydronic Balance

The insert can be pre-set to limit the working range of the valve which limits the maximum flow rate through the valve. Consequently, hydronic balance is achieved automatically without the use of additional balancing valves.

### Pre-setting the Maximum Flow Rate

The valve is adjusted to a maximum flow rate limit by setting the scale located on the top of the FlowCon Green insert. The setting indicates one of 41 possible maximum flow rates from e.g. 3.81-20.4 GPM on FlowCon Green.2 but since the setting is stepless any flow rate in between will be obtainable. The setting is done by means of a special FlowCon key. With the actuator mounted, the pre-setting is "sealed" and the FlowCon Green insert eliminates any flow above the design flow.

For re-adjustment, simply disconnect power from the actuator and re-move the actuator from the insert. Then dial in the new required maximum flow and re-apply the actuator and connect power again.

### Actuator Mounting and Self-Calibration

When using the actuator, always be sure that power supply is turned off and the actuator is in a fully open position (turn the actuator to this position if required) before fitting the actuator to the insert.

For further information please see the installation and operation instruction manual.

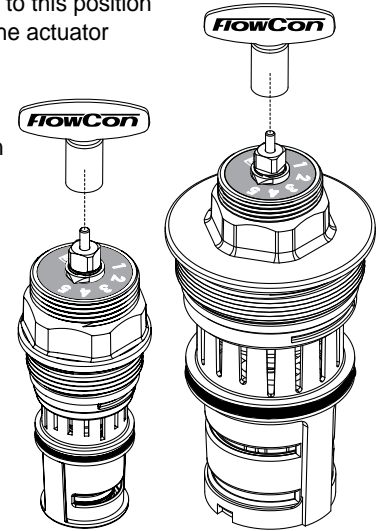

### Technical Data

For further information and part number selection please see FlowCon tech note.

		A/AB/ABV 1/2"-1" with Green insert	AB 1"-1 1/4" with Green insert ABV 1"-1 1/2" with Green insert
Static Pressure	(kPa)	2500	2500
	(psi)	360	360
Temperature Rating (media / ambient)	(°C)	-20 to +120 / 0 to +50	-20 to +120 / 0 to +50
	(°F)	-4 to +248 / +32 to +122	-4 to +248 / +32 to +122
Pressure Drop Data		NOTE: For pump head calculations, add the minimum pressure differential for the index circuit to the other components pressure losses (i.e. valves, coil, etc.)	
Valve Body	(Kv-value) (m³/hr)	2.6	12.5
	(Cv-value) (GPM)	3.0	14.5

FlowCon Green insert		Green.0 (green o-ring)	Green.1 (black o-ring)	Green.2 (black o-ring)
Pressure Differential	(kPaD)	16-200	30-400	16-400 (at setting 2.6)
	(psid)	2.3-29	4.4-58	2.3-58 (at setting 2.6)
Flow Rate	(l/sec)	0.0089-0.210	0.0178-0.308	0.240-1.29
	(GPM)	0.141-3.33	0.282-4.89	3.81-20.4

