

FlowCon DPCV



Differential Pressure Control Valves

FLOW

FlowCon DPCV

Differential Pressure Control Valves

The FlowCon DPCV is designed for controlling differential pressure in water based heating and air-conditioning systems, ensuring constant pressure drop over two specific points of the water system regardless of pressure and flow fluctuations.

The FlowCon DPCV will allow the user to set the valve to a pre-defined differential pressure value. To make the installation as easy as possible the setting is done by hand without any usage of tools. To make installation even easier, no special measuring equipment or conversion tables are required during adjustment, since the settings are printed directly on the handle. Once the installation process is completed, the valve allows a tamper-proof function, when the supplied lock ring is fastened with a cable binder. Further, the FlowCon DPCV can be used as a shut-off valve for maintenance purpose.

In heating systems the FlowCon DPCV is primarily intended to be used on the risers or branches with the aim of maintaining a constant differential pressure between the supply and return side. Consequently, for the sub system controlled by the FlowCon DPCV, water velocity through the radiator valves is reduced and potential noise at part loads is minimized.

In cooling systems the FlowCon DPCV is installed in order to absorb any pressure fluctuations introduced by system load changes and potentially VFD pumps, if installed. The absorption of pressure will lead to reduced flow fluctuations and thereby improved balancing and improved energy consumption of the building.

Features and Benefits

- **Rugged, robust design in bronze/brass.**
- **All functions located on one side** for easier access and use.
- **High flow rates.**
- **Wide pre-setting range** with stepless ΔP -scale and without any need of tools.
- **Lockable pre-setting.**
- **Capillary tube** with $\frac{1}{4}$ " male ISO thread connection, fitting many valve types (including all FlowCon AB/ABV/ABM housings).
- **Available with up to 3 pressure/temperature plugs** for maximum measurement options - possibility of measuring the pressure at:
 - the capillary tube
 - the inlet of the DPCV
 - the outlet of the DPCV.
- Can be used as a **shut-off valve** during maintenance.



Principle of Operation

The FlowCon DPCV controls the differential pressure between the capillary tube and the inlet of the DPCV. The FlowCon DPCV regulates the differential pressure by means of a diaphragm element counteracted by a spring. The diaphragm element is connected to a cone, which movements change the size of the orifice until the controlled differential pressure is reached. When pre-setting the differential pressure, the spring is tightened or loosened so that the balance will be found at a higher or lower differential pressure than before. When the valve is used as a shut-off valve, the cone closes off the orifice.

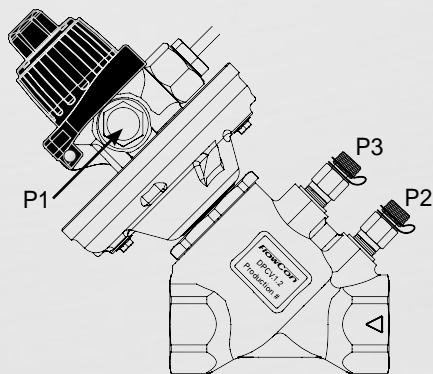

Pressure Verification

Optional pressure/temperature test plugs are available for verifying the differential pressure. They are fitted into 1/4" ISO female threaded ports. With the pressure/temperature plugs fitted, a pressure differential reading across the FlowCon DPCV can be taken (P2÷P3). Using a combination of other pressure/temperature plugs the controlled pressure differential across the riser or branch can be read (P1÷P2).

Differential Pressure Setting

For adjusting the differential pressure range of the FlowCon DPCV simply lift the lock-ring and turn the handle to the required setting without using additional tools. Settings can be read directly on the scale on the handle. As an example, a setting 10 corresponds to a ΔP of 10 kPaD (1.5 psid) equal for all FlowCon DPCV valve sizes (DN15-50). But each valve provides a wide stepless setting range between 5 and 35 kPaD (0.7-5.1 psid).

After setting ΔP the lock-ring is re-fitted and can optionally be locked with a cable binder securing the valve to be tamper-proof.

Shut-off Function

The built-in shut-off function is activated by turning with an Allen key counter-clockwise at top of the FlowCon DPCV handle until the end point. Opening the FlowCon DPCV again is done with a clockwise movement with the Allen key until end point. The ΔP setting is kept as per memory stop.

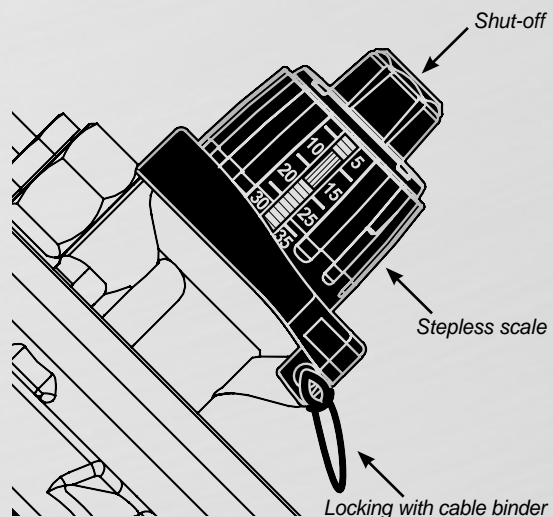

Technical Data

For further information please see FlowCon tech notes.

Valve size		DPCV DN15	DPCV DN20	DPCV DN25	DPCV DN32	DPCV DN40	DPCV DN50
Static Pressure	(kPa)	1600					
	(psi)	232					
Temperature Rating (media)	(°C)	+130					
	(°F)	+266					
Pressure Drop Data		NOTE: For pump head calculations, add the minimum pressure differential for the index circuit to the other components pressure losses (i.e. valves, coil, etc.)					
Valve	Kv-value (m ³ /hr)	3.6	5.8	7.1	15.4	22.0	35.8
	Cv-value (GPM)	4.2	6.7	8.2	17.9	25.5	41.5
Differential pressure range	(kPaD)	5-35					
	(psid)	0.7-5.1					
Flow Rate	(l/hr)	50-1700	70-2600	110-3000	150-6500	200-9000	500-13000
	(GPM)	0.22-7.48	0.31-11.5	0.48-13.2	0.66-28.6	0.88-39.6	2.20-57.2

