

FlowCon AHU-Wafer 50-80mm

Automatic Balancing Valve - Pre-Set Cartridge



SPECIFICATIONS

Pressure rating:	2500 kPa / 360 psi
Temperature rating, media:	-20°C to +135°C / -4°F to +275°F
Material:	
- Cartridge:	AISI type 304 stainless steel AISI type 17-7 PH stainless steel spring
- Body tappings:	1/4" NPT
- Body:	Ductile iron ASTM A536, class 60-40-18/EN-GJS-400-18
- O-rings:	EPDM
- Retaining clip:	AISI type 302 stainless steel
End connections:	DIN flanges according to EN1092-1, PN10+ Size 2": ANSI B 16.5 300lb class flanges Size 2 1/2"-3": ANSI B 16.5 150lb class flanges Flanges are not supplied by FlowCon. Studs and nuts are available upon request
Flow rate range:	0.883-10.10 l/sec

DIMENSIONS AND WEIGHTS (NOMINAL) (measured in mm unless noted)

Model no.	Valve size (mm)	Valve size (")	Cartridge size	Flanges ¹				L	D1	D2	H	Weight (kgs.)
				ANSI ASME B16.5		EN 1092-1						
				Class	D3 (")	PN	D3 (mm)					
F386.x.L.B	50	2	80	300 and up	6 1/2	10 and up	165	174.5	81.5	107.0	140.0	4.4
F386.x.M.B	65	2 1/2		150 and up	7	10 and up	185			117.5	144.0	6.5
	80	3		150 and up	7 1/2	10 and up	200					

Note 1: Smallest pressue class weld neck flange fitting.

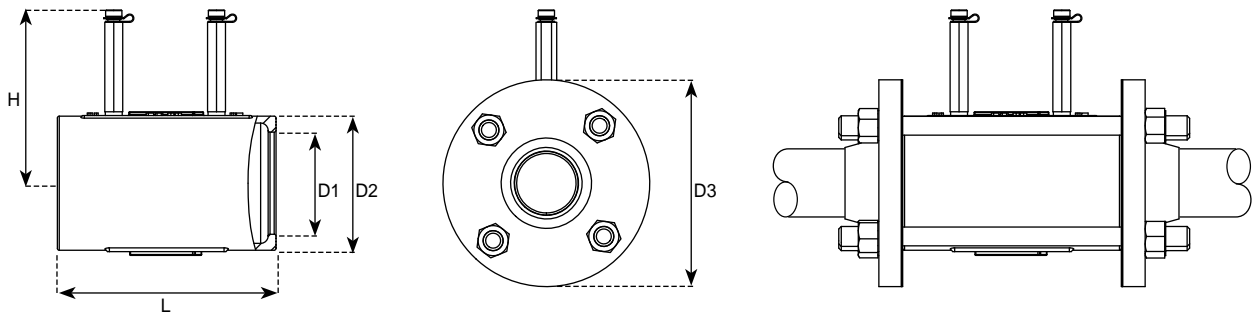

MODEL NUMBER SELECTION

Insert a kPaD control range:

0=None 1=10-135 kPaD 2=22-210 kPaD 4=40-390 kPaD 8=90-880 kPaD

Insert body size:

L=50mm M=65/80mm

Insert p/t plug requirement:

B=Pressure/temperature plugs (standard)

Example: F386.0.M.B=AHU Wafer for 65/80mm flanges with p/t plugs and no cartridge.

Note: Please specify flow requirements as per selection chart when ordering with cartridge.

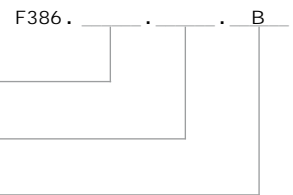

FLOW RATE TABLE

80mm · 3" · stainless steel cartridge											
Nominal flow rate	Pressure range, ΔP:			10-135 kPaD 1-20 psid		22-210 kPaD 2-32 psid		40-390 kPaD 4-57 psid		90-880 kPaD 8-128 psid	
	l/sec	l/hr	GPM	Type 1		Type 2		Type 4		Type 8	
				Marking	FlowCon	Marking	FlowCon	Marking	FlowCon	Marking	FlowCon
0.883	3180	14.0	35-1	F324135							
1.01	3630	16.0	40-1	F324140							
1.10	3970	17.5			35-2	F324235					
1.14	4090	18.0	45-1	F324145							
1.26	4540	20.0	50-1	F324150	40-2	F324240					
1.39	5000	22.0	55-1	F324155							
1.42	5110	22.5			45-2	F324245					
1.47	5300	23.3					35-4	F324435			
1.51	5450	24.0	60-1	F324160							
1.58	5680	25.0			50-2	F324250					
1.64	5910	26.0	65-1	F324165							
1.68	6060	26.7					40-4	F324440			
1.73	6250	27.5			55-2	F324255					
1.77	6360	28.0	70-1	F324170							
1.89	6810	30.0	75-1	F324175	60-2	F324260	45-4	F324445			
2.02	7270	32.0	80-1	F324180							
2.05	7380	32.5			65-2	F324265					
2.10	7570	33.3					50-4	F324450			
2.15	7720	34.0	85-1	F324185							
2.21	7950	35.0			70-2	F324270			35-8	F324835	
2.27	8180	36.0	90-1	F324190							
2.31	8330	36.7					55-4	F324455			
2.37	8520	37.5			75-2	F324275					
2.40	8630	38.0	95-1	F324195							
2.52	9080	40.0	100-1	F3241100	80-2	F324280	60-4	F324460	40-8	F324840	
2.65	9540	42.0	105-1	F3241105							
2.68	9650	42.5			85-2	F324285					
2.73	9840	43.3					65-4	F324465			
2.78	9990	44.0	110-1	F3241110							
2.84	10200	45.0			90-2	F324290			45-8	F324845	
2.90	10400	46.0	115-1	F3241115							
2.94	10600	46.7					70-4	F324470			
3.00	10800	47.5			95-2	F324295					
3.03	10900	48.0	120-1	F3241120							
3.15	11400	50.0	125-1	F3241125	100-2	F3242100	75-4	F324475	50-8	F324850	
3.28	11800	52.0	130-1	F3241130							
3.31	11900	52.5			105-2	F3242105					
3.36	12100	53.3					80-4	F324480			
3.41	12300	54.0	135-1	F3241135							
3.47	12500	55.0			110-2	F3242110			55-8	F324855	
3.53	12700	56.0	140-1	F3241140							
3.58	12900	56.7					85-4	F324485			
3.63	13100	57.5			115-2	F3242115					
3.66	13200	58.0	145-1	F3241145							
3.79	13600	60.0	150-1	F3241150	120-2	F3242120	90-4	F324490	60-8	F324860	
3.94	14200	62.5			125-2	F3242125					
4.00	14400	63.3					95-4	F324495			
4.10	14800	65.0			130-2	F3242130			65-8	F324865	
4.21	15100	66.7					100-4	F3244100			
4.26	15300	67.5			135-2	F3242135					
4.42	15900	70.0			140-2	F3242140	105-4	F3244105	70-8	F324870	
4.57	16500	72.5			145-2	F3242145					
4.63	16700	73.3					110-4	F3244110			
4.73	17000	75.0			150-2	F3242150			75-8	F324875	
4.84	17400	76.7					115-4	F3244115			
5.05	18200	80.0					120-4	F3244120	80-8	F324880	
5.26	18900	83.3					125-4	F3244125			
5.36	19300	85.0							85-8	F324885	
5.47	19700	86.7					130-4	F3244130			
5.68	20400	90.0	220-1	F3241220*			135-4	F3244135	90-8	F324890	
5.89	21200	93.3					140-4	F3244140			
5.99	21600	95.0							95-8	F324895	
6.10	22000	96.7					145-4	F3244145			
6.31	22700	100					150-4	F3244150	100-8	F3248100	
6.62	23800	105							105-8	F3248105	
6.94	25000	110	270-1	F3241270*	220-2	F3242220**			110-8	F3248110	
7.26	26100	115							115-8	F3248115	
7.57	27300	120							120-8	F3248120	
7.89	28400	125							125-8	F3248125	
8.20	29500	130	320-1	F3241320*					130-8	F3248130	
8.52	30700	135			270-2	F3242270**			135-8	F3248135	
8.83	31800	140							140-8	F3248140	
9.15	32900	145							145-8	F3248145	
9.46	34100	150							150-8	F3248150	
10.10	36300	160			320-2	F3242320**					

Accuracy: ±5% of controlled flow rate.

* Standard flow, high capacity: the pressure range for these flow rates is 28-135 kPaD (4-20 psid).
 ** Standard flow, high capacity: the pressure range for these flow rates is 55-210 kPaD (8-32 psid).

GENERAL SPECIFICATIONS

1. AUTOMATIC BALANCING VALVES - FLOWCON AHU-WAFER

- 1.1. Contractor shall install automatic balancing valves where indicated in drawings.
- 1.2. Valve shall consist of a dynamic, flow limiting device.

2. VALVE HOUSING

- 2.1. Valve housing shall consist of ductile iron ASTM A536-80, class 60-40-18, rated at no less than 2500 kPa static pressure and +135°C.
- 2.2. Valve housing shall be permanently marked to show direction of flow.
- 2.3. Dual pressure/temperature test plugs for verifying accuracy of flow performance shall be provided for all valve sizes.
- 2.4. Valve housing shall be compatible with ANSI B 16.5 150 lb/300 lb steel flanges (depending on size) and be compatible to DIN PN10+ flanges according to EN1092-1.

3. FLOW REGULATOR / AUTOMATIC BALANCING UNIT

- 3.1. Flow regulation unit assembly shall be manufactured of AISI type 304 stainless steel and stainless steel 17-7 spring.
- 3.2. Flow regulation unit shall be available in 4 different kPaD operational range; minimum range shall be capable of being activated by minimum 10 kPaD. Further, the flow regulation unit shall be capable of controlling flow within $\pm 5\%$ of rated flow.
- 3.3. Identification tags shall be available for all valves; tags shall be indelibly marked with part number and flow rate.

UPDATES

FlowCon International A/S can accept no responsibility for possible errors in any printed material.
All rights reserved.