

INSTALLATION AND OPERATION INSTRUCTION

FlowCon ABM 15-40mm, 1/2"-1 1/2"

Install the **FlowCon ABM** as called for in the design drawings. Although the performance of the valve is not affected either way, industry standards call for balancing devices to be installed on the downstream side of the terminal unit. Especially for the ABM with its Optimizer® ball valve, it is recommended to ensure the ball valve is downstream of the balancing device. **INSTALL THE VALVE HOUSING WITH THE FLOW DIRECTIONAL ARROW POINTING IN THE CORRECT DIRECTION.**

The **FlowCon ABM** valve is available with double union end connections, i.e. figure 1.

Figure 1

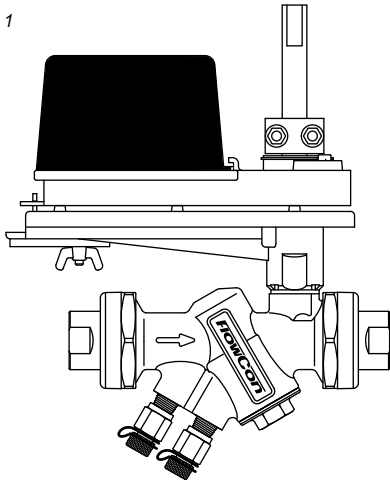

Two types of end connections are available for use with the union nut

Threaded (male or female):

The thread standard is ISO 228, which is a straight metric thread (compatible with BS-2779) or NPT threading standard, depend-

ing on the end connections ordered. The threads on both the connection and piping should be cleaned carefully. As these models are union end connected, the union nuts and the end connections should be removed for installation.

O-rings are supplied with the valve body and used to seal the connections. It is recommended to grease the o-rings with silicone grease before installation. **IMPORTANT:** Never use mineral oil or petrol based grease or oil on the o-rings. Please make sure these are in place in the o-ring grooves in the inlet and outlet of the valve body, when installing the housing and **REMEMBER TO TIGHTEN THE UNION NUTS TO ENSURE SEALING.**

For all thread connections please clear threads on both valve and piping of debris. Sealant such as pipe dope or teflon tape is recommended. **WHEN USING HEMP AS PIPE SEALANT, ENSURE NO STRANDS ARE LEFT IN THE VALVE OR PIPING.**

Soldered end:

REMOVE THE END CONNECTIONS FROM THE HOUSING BEFORE SOLDERING. THIS ENSURES THAT THE O-RINGS AND INTERNAL PARTS ARE NOT DAMAGED BY HEAT.

Pressure/temperature fittings (p/t plugs) are available upon request for the ABM valve. Before finger mounting the p/t plugs in the body tappings, please seal the threads of the p/t plugs (**DO NOT OVER TIGHTEN**).

Alternatively to the p/t plugs, the valve body can be ordered with **plugs** for the body tappings. Each plug is sealed by a gasket.

Actuators:

The ABM valve should be installed so that the actuator is located upwards and higher above the valve center-line to prevent condensation into the electronics. Valves are supplied in open position.

Figure 2

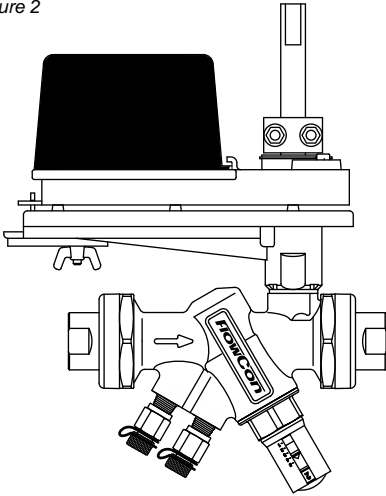
**Mechanical installation:**

- 1) Depress the clutch and manually close the damper blades and position the actuator at 0° or 90° so that the damper and the actuator coincide. NOTE: do not clutch the actuator when the power is on.
- 2) Slide the actuator onto the shaft.
- 3) Tighten the nuts on the "U"-bolt to the shaft with an 8mm wrench to a torque of 6.7Nm.
- 4) Slide the mounting bracket under the actuator. Ensure free movement of the slot at the base of the actuator. The bracket pin must be placed in the mid distance of the slot.

Manual over-ride operation:

- 1) DISCONNECT POWER. Failure to disconnect power may cause damage to the actuator gears.
- 2) Fit the manual over-ride key onto the valve spindle.
- 3) Press the clutch.
- 4) Rotate the manual over-ride key to open or close the valve as required. CW will close the valve and CCW will open the valve.

Figure 3

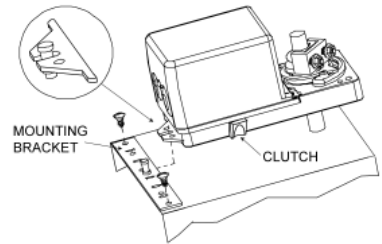
**Actuator wiring:**

- 1) Remove the actuator cover by loosening the cover screw.
- 2) Connect the wiring, pls. see figures 4-6. Screw-terminals 6, 7 and 8 are only used on actuators with end switches.
- 3) SW1 controls the direction of the rotation, please see figures 4-6 for clock-wise (0 to 90°) and counter-clock-wise (90 to 0°) rotation.
- 4) For actuators with end switches, the mechanical auxiliary switches are fixed at 10° and 80°.

Figure 4

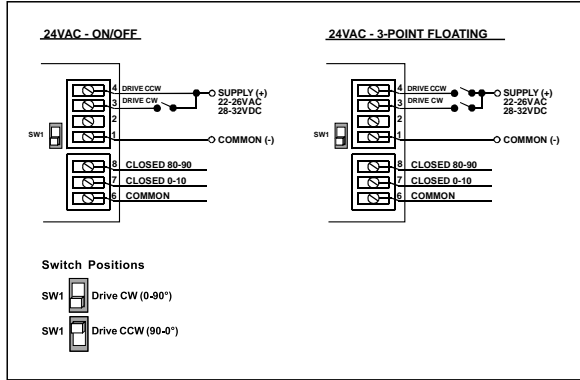

Figure 5

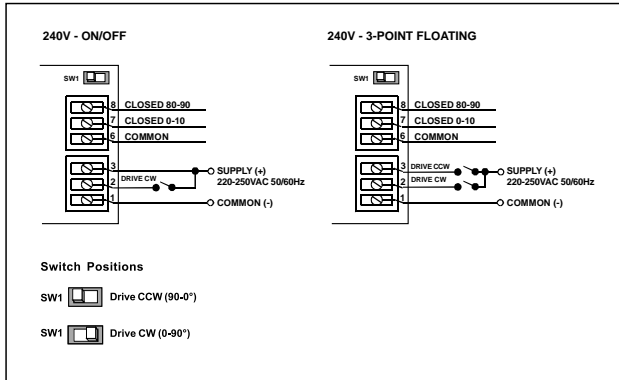
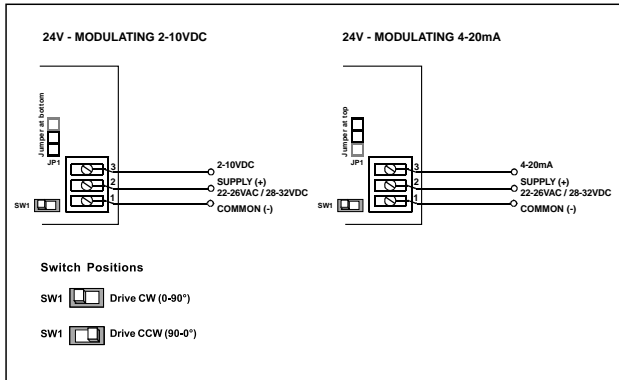

Figure 6



Choice of cartridge:

FlowCon ABM valves can be installed with either a standard composite cartridge, internally adjustable to one of eight flow rates or the FlowCon E-JUST cartridge, externally adjustable to one of 41 different flow rates in the same cartridge. Alternatively, a factory-set stainless steel cartridge can be installed with an adaptor.

The new composite part is placed into the brass head nut. Please be aware of the two marks on each side of the composite part; these must fit into the two grooves on the brass head nut. When in place, push the two parts together until they click and the adaptor is ready for use.

It is recommended that the o-rings located around the cartridge and adaptor are lubricated with silicone grease, before the cartridge/adaptor is installed into the valve body. **IMPORTANT:** Never use mineral oil or petrol based grease or oil on the o-rings.

If the stainless steel cartridge needs to be exchanged, it is necessary to slightly cut the sides of the grips on the adaptor with a box knife and remove the cartridge by pulling the two now flexible grips outwards on each side of the adaptor with one hand and pulling the stainless steel cartridge from the adaptor with the other. The o-ring will come out as well.

Before installing the replacement cartridge, the black composite part also needs to be replaced. Simply remove the composite part using a small piece of steel or brass bar or similar tool ($\varnothing 10\text{mm}$ and 150mm length). Place the ancillary tool through the composite part and push down until the part loosens a little; no need to use much force. Then do the exact same thing from the opposite side of the part and the composite part is now free and can be easily removed from the brass head nut by hand.

**Assembly drawing
FlowCon ABM:**

- A: Valve housing
- B1: E-JUST cartridge
- B2: Standard composite cartridge
- B3: Stainless steel cartridge w. adaptor
- C: Adjustment key
- D1: P/t plug (2 pcs.)
- D2: Plug and gasket (2 of each)
- E: Union end connections
- F: Actuator.

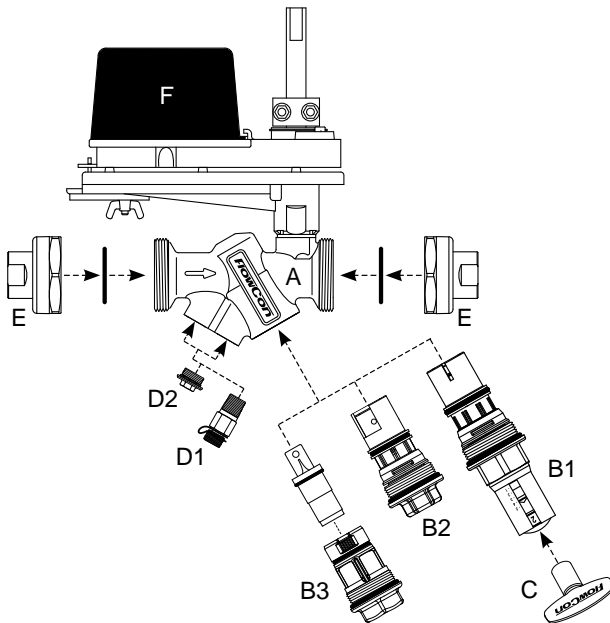

Figure 7

General.

It is recommended flushing the system before installing the cartridge in the valve body. Suitable flushing caps are available. Water must always be suitable treated, clean and free of debris. It is recommended that a strainer be installed prior to the valve body to prevent damage or blockage due to debris. Ensure that the valve is not in the fully closed position when filling the system with water. Further it is recommended not to exceed maximum differential pressure control range for the cartridge, particularly for the diaphragm type.

Warranty obligation.

Failure to abide by all recommendations as per this installation and operation instruction will void warranty.