



# Air Conditioning Technical Data



EEDEN15-100

RXZ-N



# TABLE OF CONTENTS

## RXZ-N

1	Features .....	2
2	Specifications .....	3
	Capacity and Power input .....	3
	Technical Specifications .....	3
	Electrical Specifications .....	5
3	Electrical data .....	6
4	Options .....	7
5	Capacity tables .....	8
	Cooling/Heating Capacity Tables .....	8
6	Dimensional drawings .....	11
7	Piping diagrams .....	12
8	Wiring diagrams .....	13
	Wiring Diagrams - Single Phase .....	13
9	Sound data .....	14
	Sound Pressure Spectrum - Cooling .....	14
	Sound Pressure Spectrum - Heating .....	15
10	Operation range .....	16

# 1 Features

- Air-to-air heat pumps obtain 80% of their output energy from a renewable source
- SEER + SCOP = A+++ on the entire range
- First R-32 air-to-air heat pump in the European market
- Outdoor units are fitted with a swing compressor, renowned for its low noise and high energy efficiency
- Daikin outdoor units are neat, sturdy and can easily be mounted on a roof or terrace or simply placed against an outside wall
- Outdoor units for pair application



Inverter



Auto cooling-  
heating  
changeover

## 2 Specifications

2-1 Capacity and Power input				FTXZ25N/RXZ25N	FTXZ35N/RXZ35N	FTXZ50N/RXZ50N	
Cooling capacity	Min.		kW	0.6			
			Btu/h	2,000			
			kcal/h	520			
	Nom.		kW	2.5	3.5	5.0	
			Btu/h	8,500	11,900	17,100	
			kcal/h	2,150	3,010	4,300	
	Max.		kW	3.9	5.3	5.8	
			Btu/h	13,100	18,100	19,400	
			kcal/h	3,350	4,560	4,990	
Heating capacity	Min.		kW	0.6			
			Btu/h	2,000			
			kcal/h	520			
	Nom.		kW	3.6	5.0	6.3	
			Btu/h	9,600	17,100	21,500	
			kcal/h	2,150		5,420	
	Max.		kW	7.5	9.0	9.4	
			Btu/h	25,500	30,700	32,000	
			kcal/h	6,450	7,740	8,080	
Power input	Cooling	Min.	kW	0.11			
		Nom.	kW	0.41	0.66	1.10	
		Max.	kW	0.88	1.33	1.60	
	Heating	Min.	kW	0.10			
		Nom.	kW	0.62	1.00	1.41	
		Max.	kW	2.01	2.53	2.64	
Seasonal efficiency (according to EN14825)	Cooling	Energy label		A+++			
		Pdesign	kW	2.50	3.50	5.00	
		SEER		9.54	9.00	8.60	
		Annual energy consumption	kWh	92	136	203	
	Heating (Average climate)	Energy label		A+++			
		Pdesign	kW	3.50	4.50	5.60	
		SCOP		5.90	5.73	5.50	
		Annual energy consumption	kWh	831	1,100	1,427	
Piping connections	Liquid	OD	mm	6.35			
	Gas	OD	mm	9.5			
Current	Nominal running current (RLA) - 50Hz	Cooling	A	2.0 (1) / 1.9 (2) / 1.9 (3)	3.1 (1) / 2.9 (2) / 2.8 (3)	5.1 (1) / 4.9 (2) / 4.6 (3)	
		Heating	A	2.9 (1) / 2.8 (2) / 2.7 (3)	4.6 (1) / 4.4 (2) / 4.3 (3)	6.5 (1) / 6.2 (2) / 6.0 (3)	
Nominal efficiency	EER			6.10 (4)	5.30 (4)	4.55 (4)	
	COP			5.80 (4)	5.00 (4)	4.47 (4)	
	Annual energy consumption		kWh	205	330	550	
	Energy label	Cooling			A		
		Heating			A		

### Notes

(1) 220V

(2) 230V

(3) 240V

(4) EER/COP according to Eurovent 2012, for use outside EU only

Nominal efficiency: cooling at 35°/27° nominal load, heating at 7°/20° nominal load

2-2 Technical Specifications		RXZ25N	RXZ35N	RXZ50N
Capacity control	Method	Inverter controlled		
Casing	Colour	Ivory white		

## 2 Specifications

2

2-2 Technical Specifications					RXZ25N	RXZ35N	RXZ50N
Dimensions	Unit	Height	mm		693		
		Width	mm		795		
		Depth	mm		300		
	Packed unit	Height	mm		735		
		Width	mm		926		
		Depth	mm		430		
Weight	Unit		kg		50		
	Packed unit		kg		58		
Heat exchanger	Rows	Quantity			2 / 1		
	Fin pitch		mm		1.27 / 1.49		
	Stages	Quantity			22 / 20		
	Tube type		ø7,94 G2A tube				
	Fin	Type			Corrugated fin		
Compressor	Model				2YC40DXD		
	Type				Hermetically sealed swing compressor		
Fan	Type				PZ440		
	Air flow rate	Cooling	High	m <sup>3</sup> /min	31.0	34.4	40.4
				cfm	1,093	1,216	1,427
			Low	m <sup>3</sup> /min	22.5		
		cfm		794			
		Super low	m <sup>3</sup> /min	-			
			cfm	-			
	Heating	High	m <sup>3</sup> /min	28.3	31.5	33.1	
			cfm	999	1,113	1,170	
		Low	m <sup>3</sup> /min	16.2			
			cfm	571			
		Super low	m <sup>3</sup> /min	-			
cfm			-				
Fan motor	Model				KFD-280-71-8A		
	Output			W	71		
	Speed	Cooling	High	rpm	710	780	900
				Super low	rpm	-	
		Heating	High	rpm	700	780	820
				Super low	rpm	-	
Sound power level	Cooling		dBA	59	61	63	
	Heating		dBA	59	61	64	
Sound pressure level	Cooling	High	dBA	46	48	49	
	Heating	High	dBA	46	48	50	
Operation range	Cooling	Ambient	Min.	°CDB	-10		
			Max.	°CDB	43		
	Heating	Ambient	Min.	°CWB	-20		
			Max.	°CWB	18		
Refrigerant	Type				R-32		
	Charge			kg	1.34		
				TCO <sub>2</sub> eq	0.9		
	GWP				675		
Refrigerant oil	Type				FW68DA		
	Charged volume			l	0.405		
Piping connections	Liquid	OD	mm		6.35		
	Gas	OD	mm		9.5		
	Drain	ID	mm		-		
	Piping length	OU - IU	Max.	m	10		
	Level difference	IU - OU	Max.	m	8		
	Heat insulation				Both liquid and gas pipes		

4

## 2 Specifications

2-3 Electrical Specifications				RXZ25N	RXZ35N	RXZ50N
Power supply	Name			V1		
	Phase			1~		
	Frequency	Hz		50		
	Voltage	V		220-240		
Current	Nominal running current (RLA)	Cooling	A	1.9 (1) / 1.8 (2) / 1.8 (3)	3.0 (1) / 2.8 (2) / 2.7 (3)	5.0 (1) / 4.8 (2) / 4.5 (3)
		Heating	A	2.8 (1) / 2.7 (2) / 2.6 (3)	4.5 (1) / 4.3 (2) / 4.2 (3)	6.4 (1) / 6.1 (2) / 5.9 (3)
	Starting current	Cooling	A	2.8	4.4	6.2
		Heating	A	2.8	4.4	6.2
Current - 50Hz	Maximum fuse amps (MFA)	A	16			
Current - 60Hz	Maximum fuse amps (MFA)	A	-			
Wiring connections	For power supply	Remark	3 for power supply, 4 for interunit wiring (including earth wiring)			

### Notes

(1) 220V

(2) 230V

(3) 240V

Contains fluorinated greenhouse gases

### 3 Electrical data

#### 3 - 1 Electrical Data

3

Representative unit combination		Power supply				Comp.	OFM		IFM	
Indoor unit	Outdoor unit	Hz-volts	Voltage range	MCA	MFA	RLA	W	FLA	W	FLA
FTX25N	RXZ25N	50 - 220 50 - 230 50 - 240	Max. 50Hz 264V Min. 50Hz 198V	10.5	16	1.7	71	0.12	30	0.14
FTX35N	RXZ35N	50 - 220 50 - 230 50 - 240	Max. 50Hz 264V Min. 50Hz 198V	13.25	16	2.8	71	0.15	30	0.14
FTX50N	RXZ50N	50 - 220 50 - 230 50 - 240	Max. 50Hz 264V Min. 50Hz 198V	15	16	4.7	71	0.18	30	0.14

3D084420

---

**SYMBOLS**

MCA : Min. Circuit Amps. (A)  
MFA : Max. Fuse Amps (A)  
RLA : Rated Load Amps. (A)  
OFM : Outdoor Fan Motor.  
IFM : Indoor Fan Motor.  
FLA : Full Load Amps. (A)  
W : Fan Motor Rated Output (W)  
RHz : Rated operating frequency (Hz)

**NOTES**

1. RLA is based on the following conditions:  
Indoor temp.: 27°CDB/19°CWB  
Outdoor temp.: 35°CDB
2. Maximum allowable voltage variation between phases is 2%.
3. Select wire size based on the larger value of MCA.
4. Instead of fuse, use circuit breaker.



# 4 Options

## 4 - 1 Options

### RXZ-N

#### Outdoor Units

	RXZ25N	RXZ35N	RXZ50N
Humidifying hose (10m)		KPMH974A42	
Humidifying hose extensions set (2m)		KPMH974A402	
Humidifying hose extensions joint (10pcs.)		KPMJ942A4	
Humidifying hose L-shape joint (10pcs.)		KPMJ983A4L	
Humidifying hose L-shape cuff (10pcs.)		KPMH950A4L	

# 5 Capacity tables

## 5 - 1 Cooling/Heating Capacity Tables

FTXZ25NV1B + RXZ25NV1B

### Cooling

50Hz 220-240V

AFR	10.7
BF	0.10

Indoor		Outdoor temperature (°CDB)																																
EWB °C	EDB °C	-10			-5			0			5			10			15			20			25			30			35			40		
		TC	SHC	PI	TC	SHC	PI	TC	SHC	PI	TC	SHC	PI	TC	SHC	PI	TC	SHC	PI	TC	SHC	PI	TC	SHC	PI	TC	SHC	PI	TC	SHC	PI			
14.0	20	3.26	2.38	0.16	3.14	2.52	0.16	3.05	2.46	0.15	2.91	2.41	0.22	2.79	2.35	0.25	2.68	2.30	0.28	2.56	2.25	0.31	2.44	2.19	0.34	2.33	2.14	0.38	2.21	2.09	0.41	2.10	2.04	0.41
17.0	22	3.57	2.59	0.20	3.27	2.42	0.20	3.14	2.41	0.19	3.03	2.36	0.23	2.91	2.31	0.26	2.79	2.26	0.29	2.68	2.19	0.32	2.56	2.13	0.35	2.44	2.11	0.38	2.08	2.06	0.41	2.07	2.01	0.41
18.0	25	3.49	2.65	0.20	3.37	2.60	0.20	3.25	2.55	0.20	3.14	2.51	0.23	3.02	2.46	0.26	2.91	2.41	0.28	2.79	2.36	0.32	2.68	2.32	0.35	2.56	2.27	0.38	2.44	2.23	0.41	2.35	2.18	0.41
15.0	27	3.55	2.81	0.20	3.45	2.78	0.20	3.37	2.72	0.20	3.20	2.67	0.23	3.08	2.63	0.26	2.97	2.58	0.29	2.85	2.54	0.32	2.73	2.49	0.35	2.62	2.46	0.38	2.33	2.35	0.41	2.38	2.36	0.41
22.0	30	3.72	2.71	0.23	3.30	2.63	0.23	3.49	2.62	0.23	3.37	2.58	0.25	3.25	2.54	0.26	3.14	2.50	0.28	3.02	2.46	0.32	2.91	2.43	0.35	2.79	2.39	0.38	2.67	2.35	0.41	2.56	2.31	0.42
24.0	32	3.84	2.63	0.23	3.72	2.60	0.23	3.62	2.56	0.23	3.49	2.52	0.25	3.37	2.49	0.26	3.25	2.45	0.28	3.14	2.41	0.32	3.02	2.38	0.35	2.90	2.34	0.38	2.79	2.31	0.41	2.67	2.27	0.42

### Heating

50Hz 220-240V

AFR	11.7
-----	------

Indoor		Outdoor temperature (°CWB)											
EDB °C	°C	-15		-10		-5		0		6		10	
		TC	PI	TC	PI	TC	PI	TC	PI	TC	PI	TC	PI
15.0	1.71	0.40	2.08	0.42	2.41	0.44	3.24	0.58	3.72	0.61	4.05	0.63	
20.0	1.61	0.41	1.95	0.43	2.30	0.45	3.11	0.59	3.55	0.62	3.93	0.64	
22.0	1.57	0.41	1.91	0.44	2.26	0.46	3.06	0.59	3.55	0.63	3.88	0.65	
24.0	1.52	0.42	1.87	0.44	2.22	0.46	3.01	0.60	3.50	0.63	3.83	0.65	
25.0	1.50	0.42	1.85	0.44	2.19	0.46	2.99	0.60	3.48	0.63	3.80	0.65	
27.0	1.45	0.43	1.81	0.45	2.15	0.47	2.94	0.61	3.43	0.64	3.75	0.66	

### SYMBOLS

AFR:	Air flow rate	(m <sup>3</sup> /min)
BF:	Bypass factor	
EWB:	Entering wet bulb temp.	(°C)
EDB:	Entering dry bulb temp.	(°C)
TC:	Total capacity	(kW)
SHC:	Sensible heat capacity	(kW)
PI:	Power input	(kW)

### NOTES

1. Ratings shown are net capacities which include a deduction for indoor fan motor heat.
2.  shows nominal (rated) capacities and power input.
3. TC, PI and SHC must be calculated by interpolation using the figures in the above tables. (Figures out of the tables should not be used for calculation.)
4. About SHC which are not mentioned on the table, please calculate them with around values in direct proportion.
5. Capacities are based on the following conditions.  
Corresponding refrigerant piping length : 5.0 m  
Level difference : 0 m
6. Air flow rate (AFR) and Bypass factor (BF) are tabulated above table.

3D084393A

# 5 Capacity tables

## 5 - 1 Cooling/Heating Capacity Tables

FTXZ35NV1B + RXZ35NV1B

Indoor		Outdoor temperature (°CDB)																																
EWB	EDB	-10			-5			0			5			10			15			20			25			30			35			40		
°C	°C	TC	SHC	PI	TC	SHC	PI	TC	SHC	PI	TC	SHC	PI	TC	SHC	PI	TC	SHC	PI	TC	SHC	PI	TC	SHC	PI	TC	SHC	PI	TC	SHC	PI			
14.0	20	4.56	3.89	2.25	4.40	3.72	2.26	4.24	3.54	2.27	4.07	3.35	2.28	3.91	3.15	2.29	3.75	2.94	2.30	3.58	2.71	2.31	3.42	2.54	2.32	3.26	2.35	0.60	3.10	2.38	0.65	2.93	2.39	0.56
16.0	22	4.79	4.02	2.29	4.63	3.95	2.30	4.47	3.75	2.31	4.30	3.56	2.32	4.13	3.34	2.33	3.97	3.14	2.34	3.81	2.95	2.35	3.65	2.76	2.36	3.50	2.79	0.61	3.24	2.55	0.60	3.10	2.54	0.50
18.0	25	4.89	4.15	2.30	4.73	4.07	2.31	4.57	3.87	2.32	4.40	3.75	2.33	4.23	3.50	2.34	4.07	3.29	2.35	3.91	3.06	2.36	3.75	2.87	2.37	3.58	2.78	0.61	3.42	2.72	0.66	3.26	2.65	0.56
19.0	27	4.97	4.21	2.32	4.80	4.14	2.32	4.64	3.93	2.33	4.48	3.80	2.34	4.31	3.63	2.35	4.18	3.17	2.36	3.99	3.10	2.37	3.85	2.93	2.38	3.68	2.81	0.61	3.48	2.80	0.66	3.34	2.84	0.57
22.0	30	5.21	4.36	2.37	5.05	4.32	2.37	4.88	4.24	2.37	4.72	4.18	2.37	4.56	3.92	2.38	4.39	3.05	2.39	4.22	3.00	2.40	4.07	3.24	2.57	3.30	2.88	0.62	3.74	2.83	0.66	3.58	2.77	0.57
24.0	32	5.37	4.56	2.37	5.21	4.52	2.37	5.04	4.44	2.37	4.88	4.38	2.37	4.72	4.22	2.38	4.56	3.28	2.39	4.47	3.28	2.40	4.25	3.42	2.57	3.40	2.88	0.62	3.90	2.77	0.67	3.74	2.72	0.57

AFR	12.1
BF	0.14

Heating 50Hz 220-240V

AFR	13.3
-----	------

Indoor		Outdoor temperature (°CWB)											
EDB	°C	-15		-10		-5		0		6		10	
°C	°C	TC	PI	TC	PI	TC	PI	TC	PI	TC	PI	TC	PI
15.0	23.8	0.64	2.86	0.68	3.34	0.71	4.50	0.95	5.17	0.98	5.62	1.01	
20.0	2.23	0.66	2.71	0.69	3.13	0.75	4.32	0.95	5.00	0.97	5.45	1.03	
22.0	2.18	0.67	2.66	0.70	3.14	0.72	4.25	0.96	4.93	1.01	5.38	1.04	
24.0	2.12	0.68	2.60	0.71	3.08	0.74	4.18	0.97	4.88	1.02	5.31	1.05	
25.0	2.06	0.68	2.57	0.71	3.05	0.75	4.15	0.97	4.83	1.02	5.28	1.05	
27.0	2.03	0.69	2.51	0.72	2.99	0.75	4.08	0.98	4.76	1.03	4.83	0.96	

**SYMBOLS**

AFR:	Air flow rate	(m <sup>3</sup> /min)
BF:	Bypass factor	
EWB:	Entering wet bulb temp.	(°C)
EDB:	Entering dry bulb temp.	(°C)
TC:	Total capacity	(kW)
SHC:	Sensible heat capacity	(kW)
PI:	Power input	(kW)

**NOTES**

1. Ratings shown are net capacities which include a deduction for indoor fan motor heat.
2.  shows nominal (rated) capacities and power input.
3. TC, PI and SHC must be calculated by interpolation using the figures in the above tables. (Figures out of the tables should not be used for calculation.)
4. About SHC which are not mentioned on the table, please calculate them with around values in direct proportion.
5. Capacities are based on the following conditions.  
Corresponding refrigerant piping length : 5.0 m  
Level difference : 0 m
6. Air flow rate (AFR) and Bypass factor (BF) are tabulated above table.

3D084394A

# 5 Capacity tables

## 5 - 1 Cooling/Heating Capacity Tables

5

FTXZ50NV1B + RXZ50NV1B

Cooling 50Hz 220-240V

AFR	15
BF	0.17

Indoor		Outdoor temperature (°CDB)																																
EWB °C	EDB °C	-10			-5			0			5			10			15			20			25			30			35			40		
		TC	SHC	PI	TC	SHC	PI	TC	SHC	PI	TC	SHC	PI	TC	SHC	PI	TC	SHC	PI	TC	SHC	PI	TC	SHC	PI	TC	SHC	PI	TC	SHC	PI			
14.0	20	5.59	4.02	0.45	5.59	4.02	0.44	5.59	4.02	0.45	5.59	4.02	0.45	5.59	4.02	0.45	5.59	3.90	0.45	5.59	3.78	0.54	4.85	3.65	0.53	4.66	3.55	1.21	4.42	3.43	1.26	4.19	3.32	1.10
17.0	25	5.73	4.40	0.44	5.73	4.41	0.39	5.73	4.17	0.42	5.73	4.05	0.43	5.73	3.94	0.55	4.99	3.89	0.55	5.35	3.71	0.63	5.17	3.62	0.63	4.86	3.49	1.01	4.05	3.22	1.06	4.47	3.28	1.10
18.0	25	5.96	4.50	0.45	6.75	4.42	0.45	5.51	4.01	0.50	6.28	4.20	0.61	6.05	4.10	0.69	5.92	0.99	0.72	5.59	3.95	0.85	5.25	0.79	0.92	5.12	2.62	1.02	4.83	3.57	1.10	4.65	3.49	1.11
19.0	27	7.10	4.72	0.53	6.86	4.61	0.33	3.63	4.50	0.33	6.40	4.40	0.61	6.18	4.30	0.69	3.98	4.20	0.77	5.70	4.10	0.68	3.47	4.00	0.84	3.23	3.90	1.02	4.47	3.67	1.07	4.77	3.71	1.11
22.0	30	7.44	4.50	0.54	7.21	4.40	0.54	3.98	4.31	0.54	6.74	4.22	0.62	6.51	4.13	0.70	6.28	4.04	0.75	6.04	3.95	0.86	5.21	3.85	0.64	5.58	3.77	1.23	5.35	3.62	1.11	5.11	3.60	1.12
24.0	32	7.67	4.31	0.62	7.44	4.26	0.62	7.21	4.17	0.62	6.97	4.09	0.62	6.71	4.01	0.71	6.51	3.92	0.74	6.27	3.84	0.87	6.04	3.75	0.95	5.81	3.68	1.23	5.58	3.61	1.11	5.34	3.53	1.12

Heating 50Hz 220-240V

AFR	14.4
-----	------

Indoor		Outdoor temperature (°CWB)											
EDB °C	°C	-15		-10		-5		0		6		10	
		TC	PI	TC	PI	TC	PI	TC	PI	TC	PI	TC	PI
15.0	20.0	0.91	3.60	0.95	4.21	1.00	5.66	1.31	6.52	1.38	7.09	1.42	
20.0	26.0	0.93	3.42	0.98	4.02	1.03	5.45	1.34	6.29	1.34	6.64	1.45	
22.0	27.4	0.94	3.35	0.99	3.95	1.04	5.36	1.35	6.21	1.42	6.36	1.34	
24.0	26.7	0.95	3.27	1.00	3.88	1.05	5.27	1.37	5.88	1.36	5.88	1.24	
25.0	26.5	0.96	3.24	1.00	3.84	1.05	5.23	1.37	5.54	1.30	5.64	1.18	
27.0	25.6	0.97	3.16	1.01	3.77	1.06	5.14	1.38	5.16	1.18	5.16	1.09	

**SYMBOLS**

AFR:	Air flow rate	(m <sup>3</sup> /min)
BF:	Bypass factor	
EWB:	Entering wet bulb temp.	(°C)
EDB:	Entering dry bulb temp.	(°C)
TC:	Total capacity	(kW)
SHC:	Sensible heat capacity	(kW)
PI:	Power input	(kW)

**NOTES**

1. Ratings shown are net capacities which include a deduction for indoor fan motor heat.
2.  shows nominal (rated) capacities and power input.
3. TC, PI and SHC must be calculated by interpolation using the figures in the above tables. (Figures out of the tables should not be used for calculation.)
4. About SHC which are not mentioned on the table, please calculate them with around values in direct proportion.
5. Capacities are based on the following conditions.  
Corresponding refrigerant piping length : 5.0 m  
Level difference : 0 m
6. Air flow rate (AFR) and Bypass factor (BF) are tabulated above table.

3D084396A

# 6 Dimensional drawings

## 6 - 1 Dimensional Drawings

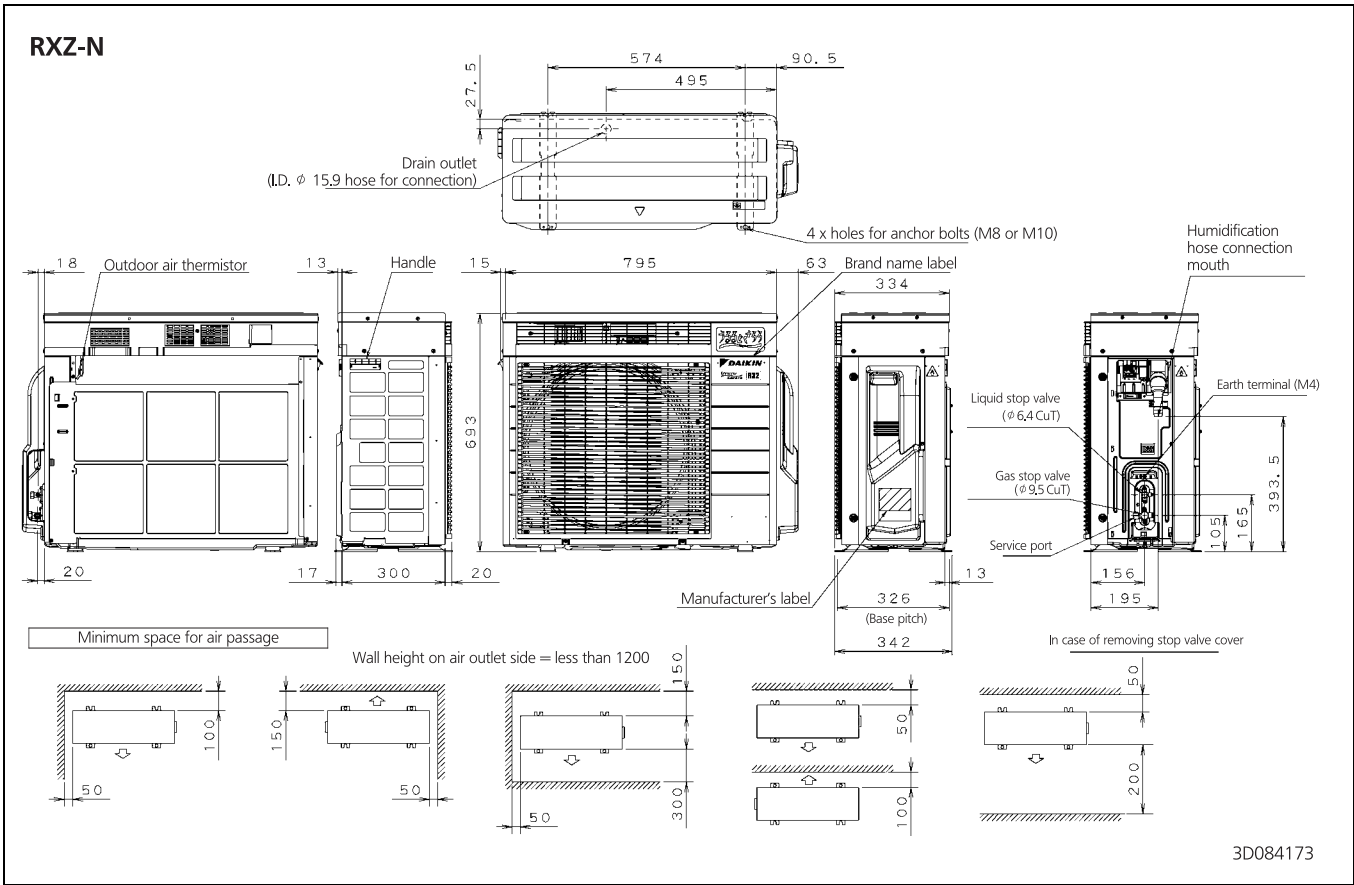

# 7 Piping diagrams

## 7 - 1 Piping Diagrams

7

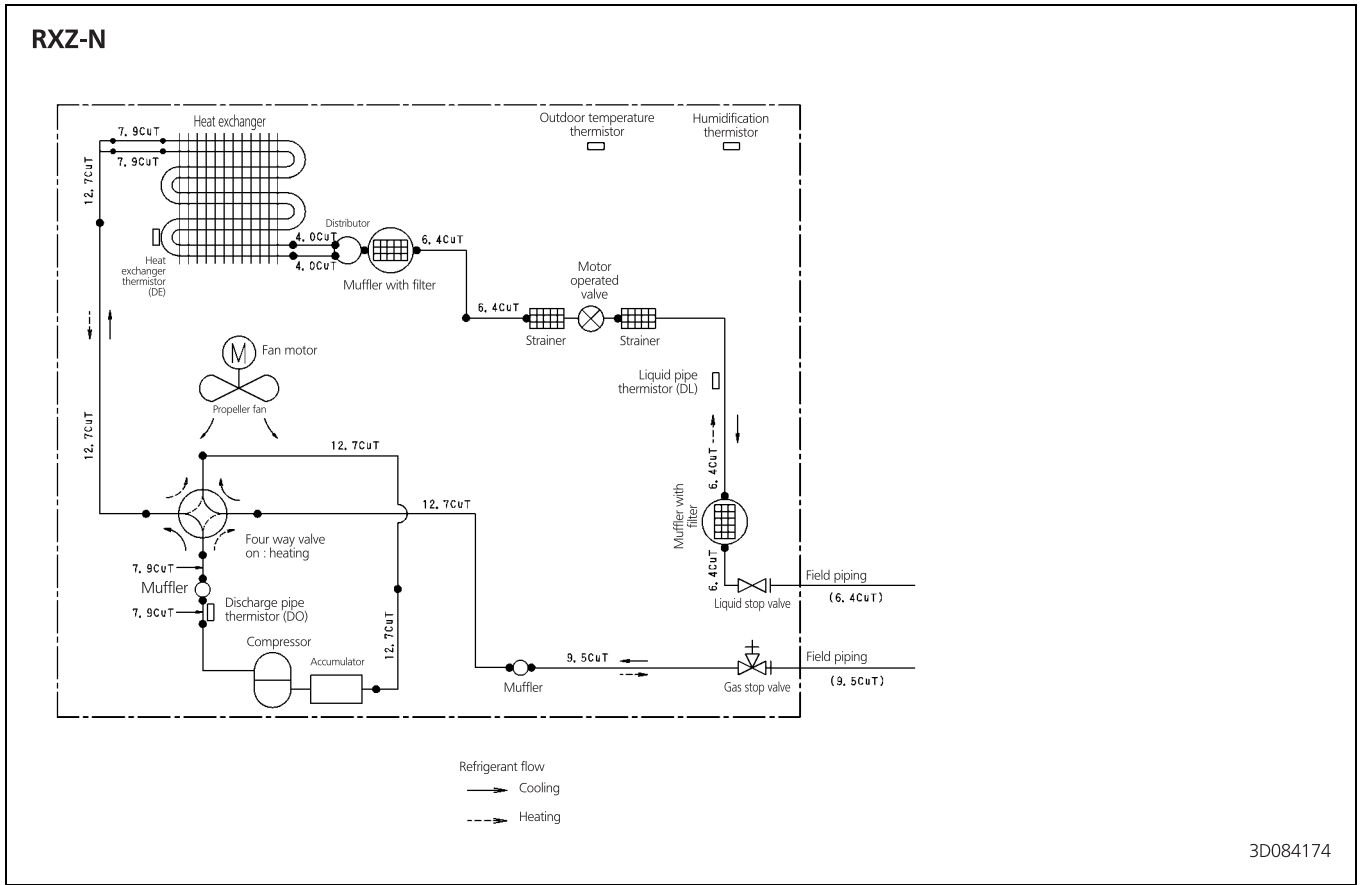

# 8 Wiring diagrams

## 8 - 1 Wiring Diagrams - Single Phase

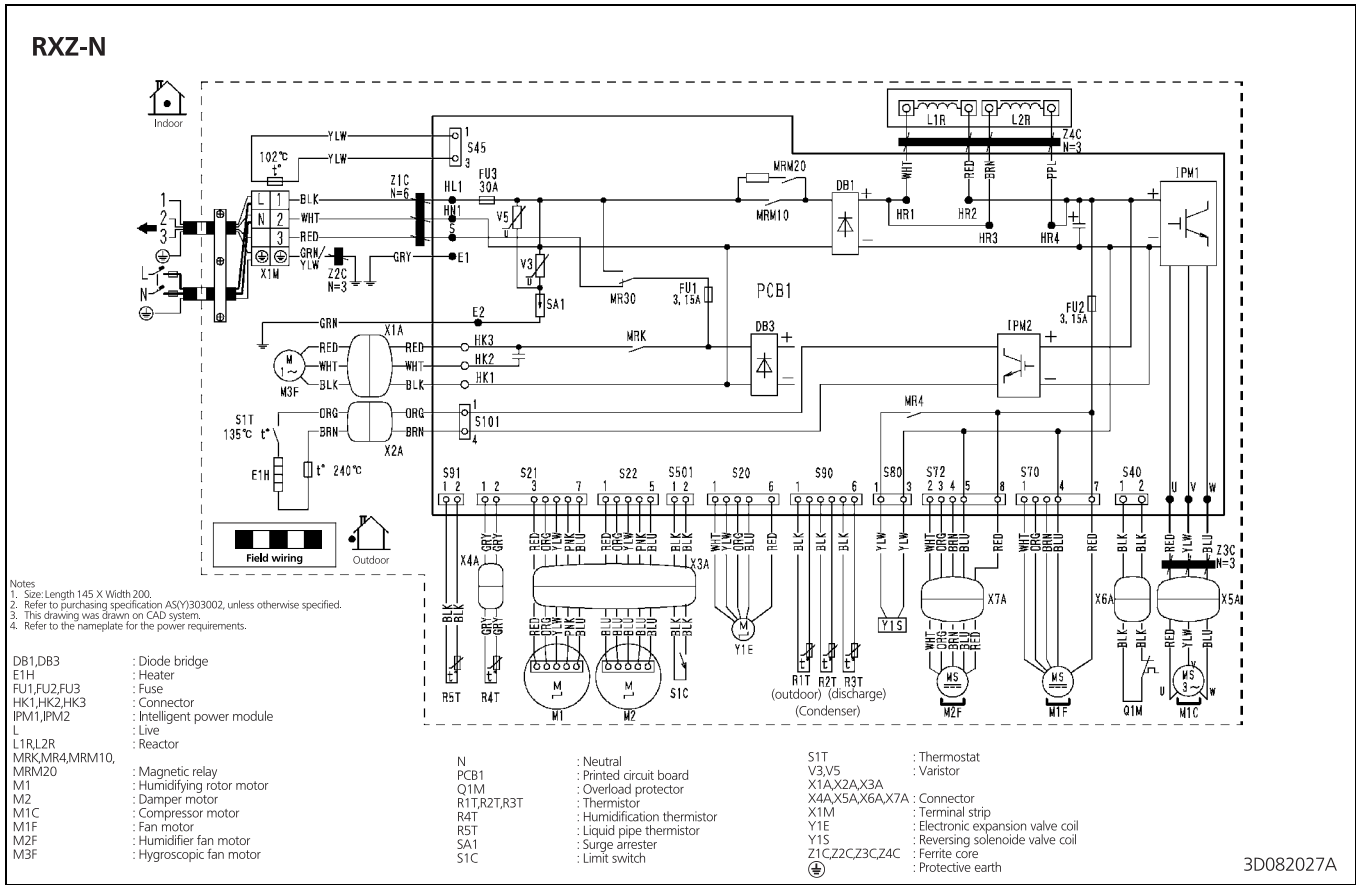

# 9 Sound data

## 9 - 1 Sound Pressure Spectrum - Cooling

9

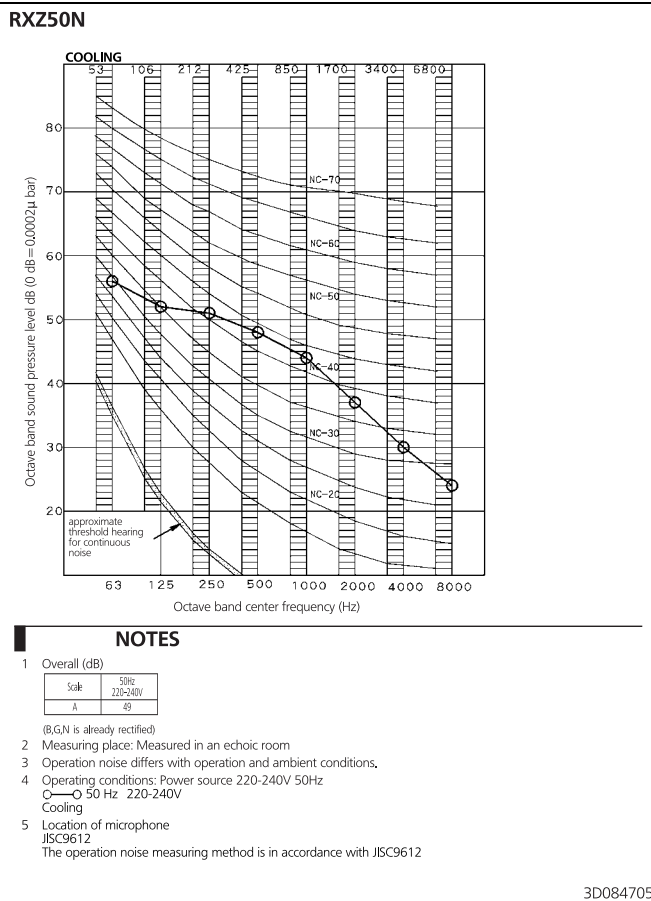
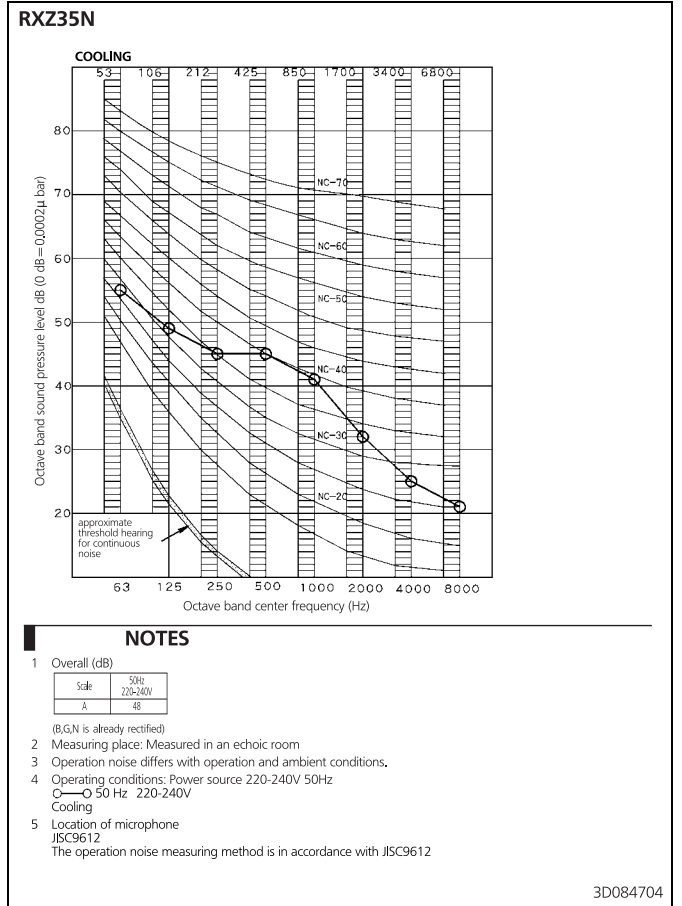
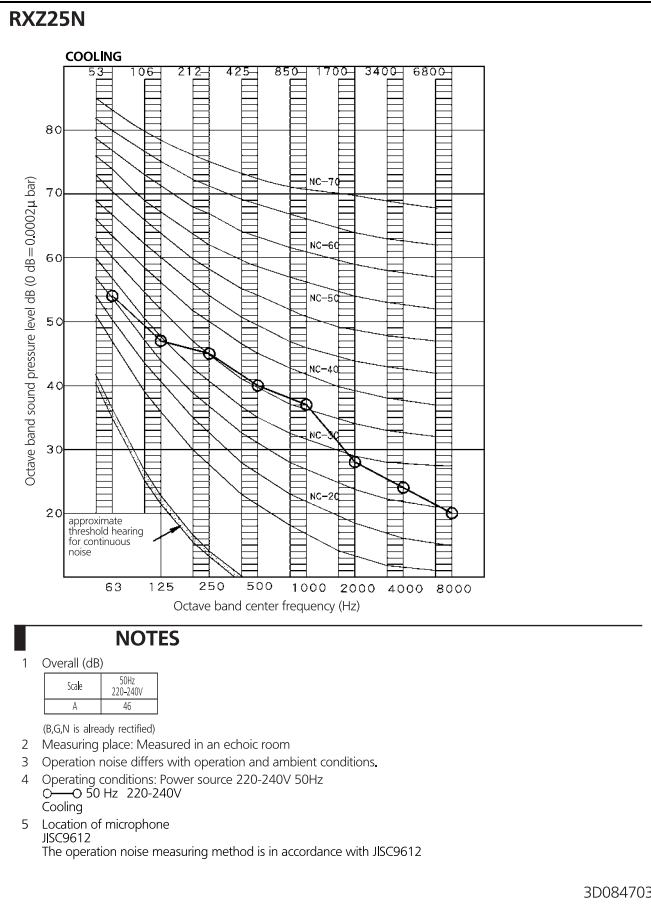



# 9 Sound data

## 9 - 2 Sound Pressure Spectrum - Heating

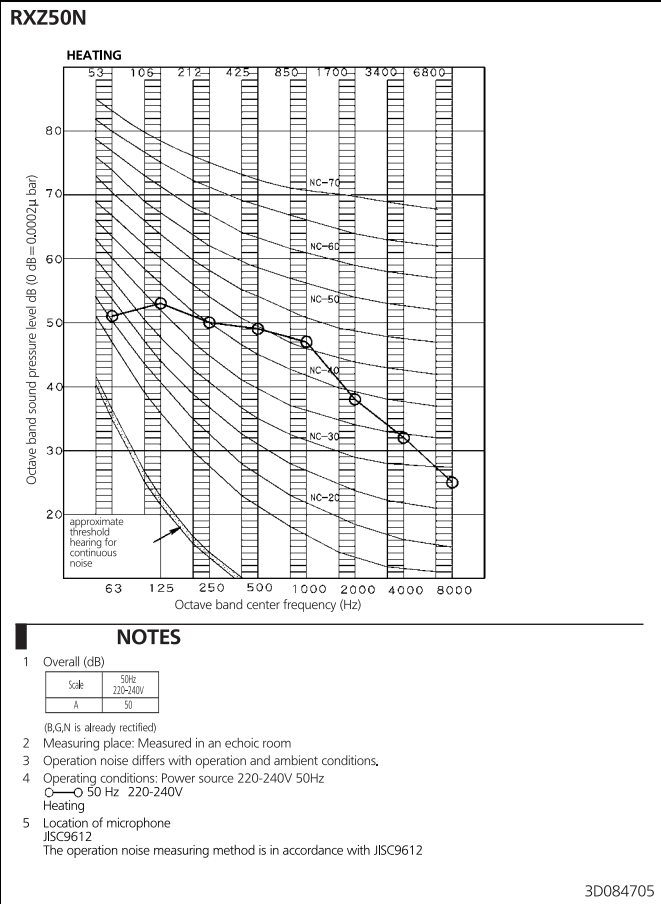
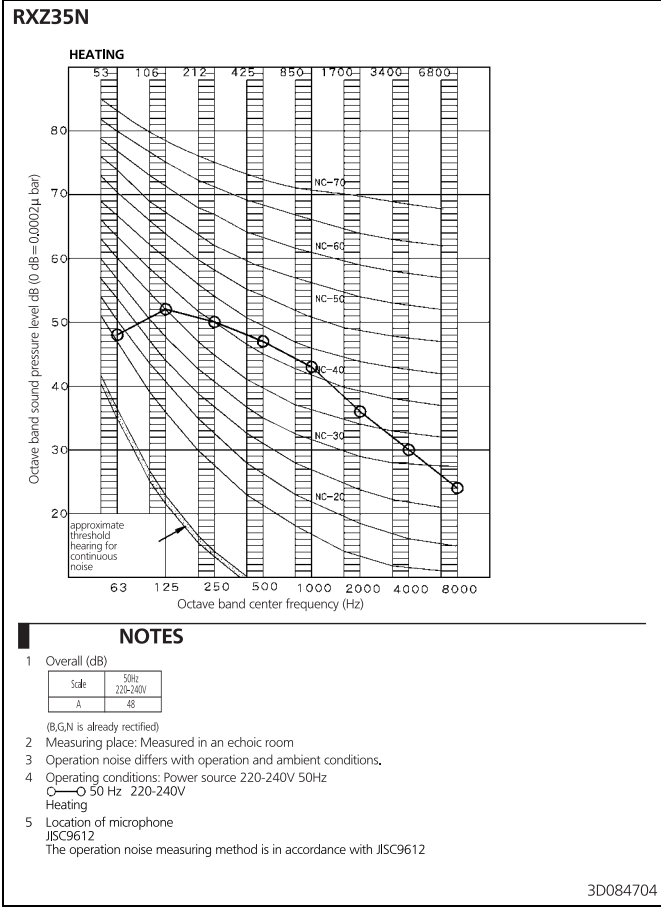
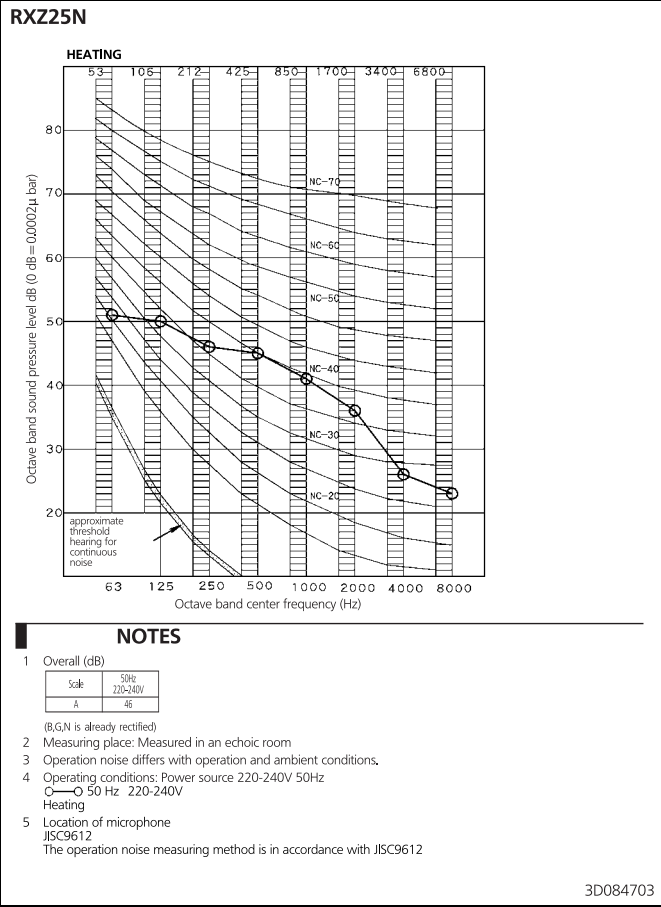

# 10 Operation range

## 10 - 1 Operation Range

10

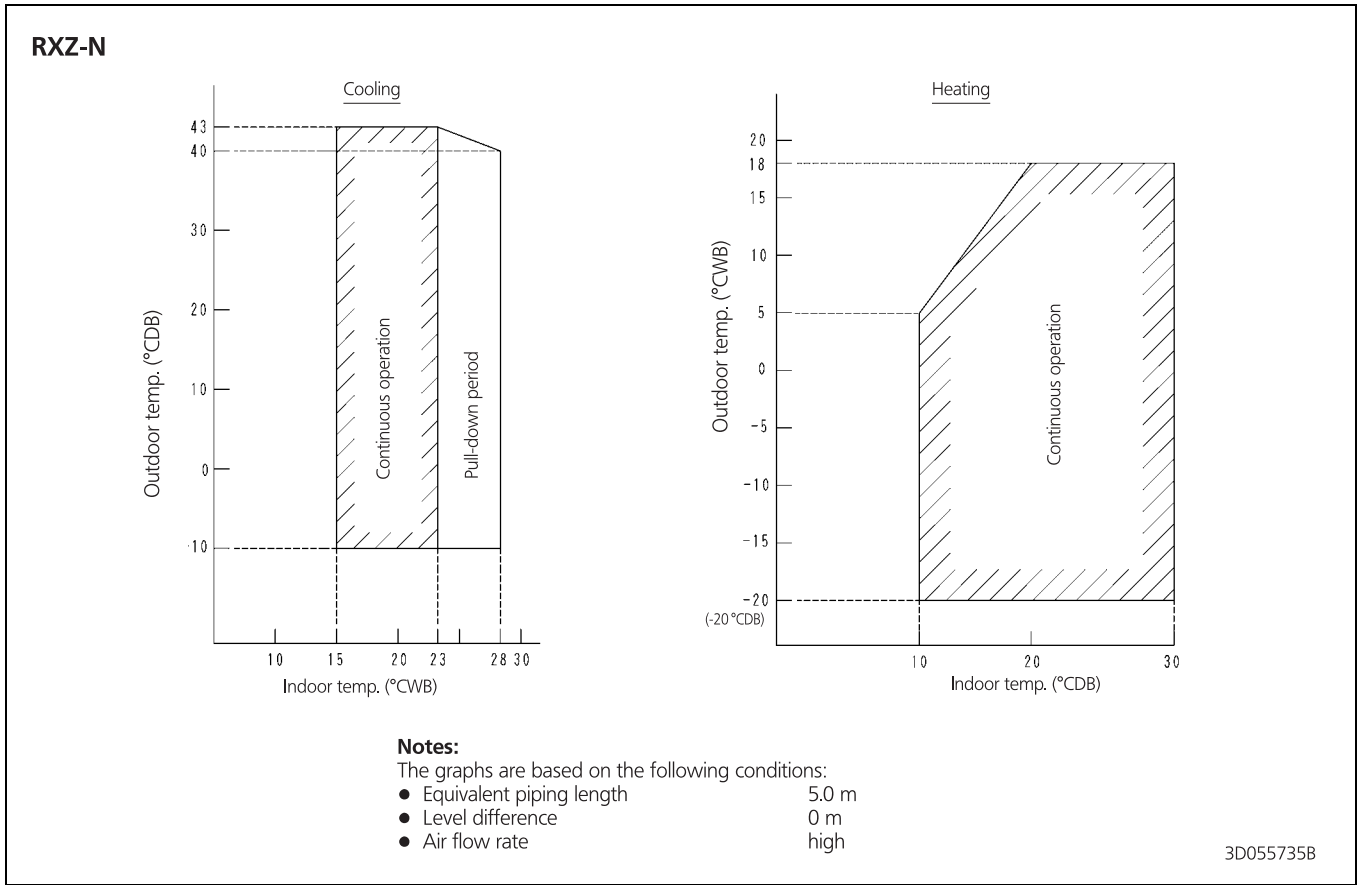



Daikin Europe N.V. participates in the Eurovent Certification programme for Liquid Chilling Packages (LCP), Air handling units (AHU), Fan coil units (FCU) and variable refrigerant flow systems (VRF) Check ongoing validity of certificate online.

The present leaflet is drawn up by way of information only and does not constitute an offer binding upon Daikin Europe N.V.. Daikin Europe N.V. has compiled the content of this leaflet to the best of its knowledge. No express or implied warranty is given for the completeness, accuracy, reliability or fitness for particular purpose of its content and the products and services presented therein. Specifications are subject to change without prior notice. Daikin Europe N.V. explicitly rejects any liability for any direct or indirect damage, in the broadest sense, arising from or related to the use and/or interpretation of this leaflet. All content is copyrighted by Daikin Europe N.V.

BARCODE

Daikin products are distributed by: