

1 Possible centralised control systems

Centralised control of the system can be achieved via 3 user friendly compact controls: centralised remote control, unified on/off control and schedule timer. These controls may be used independently or in combination where 1 group = several (up to 16) indoor units in combination and 1 zone = several groups in combination.

A centralised remote control is ideal for use in tenanted commercial buildings subject to random occupation, enabling indoor units to be classified in groups per tenant (zoning). The schedule timer programmes the schedule and operation conditions for each tenant and the control can easily be reset according to varying requirements.

2
1



Centralised remote control - DCS302C51

Providing individual control of 64 groups (zones) of indoor units.

- A maximum of 64 groups (128 indoor units, max. 10 outdoor units) can be controlled.
- A maximum of 128 groups (128 indoor units, max. 10 outdoor units) can be controlled via 2 central remote controls in separate locations.
- Zone control
- Group control
- Malfunction code display
- Maximum wiring length of 1,000m (total:2,000m)
- HRV air flow direction & air flow rate can be controlled
- Expanded timer function



Unified on/off control - DCS301B51

Providing simultaneous and individual control of 16 groups of indoor units.

- A maximum of 16 groups (128 indoor units) can be controlled
- 2 remote controls in separate locations can be used
- Operating status indication (normal operation, alarm)
- Centralised control indication
- Maximum wiring length of 1,000m (total:2,000m)



Schedule timer - DST301B51

Enabling 64 groups to be programmed.

- A maximum of 128 indoor units can be controlled
- 8 types of weekly schedule
- A maximum of 48 hours back up power supply
- A maximum wiring length of 1,000m (total:2,000m)

2 DCS302C51: Centralised remote control

2 - 1 Dimensional drawing

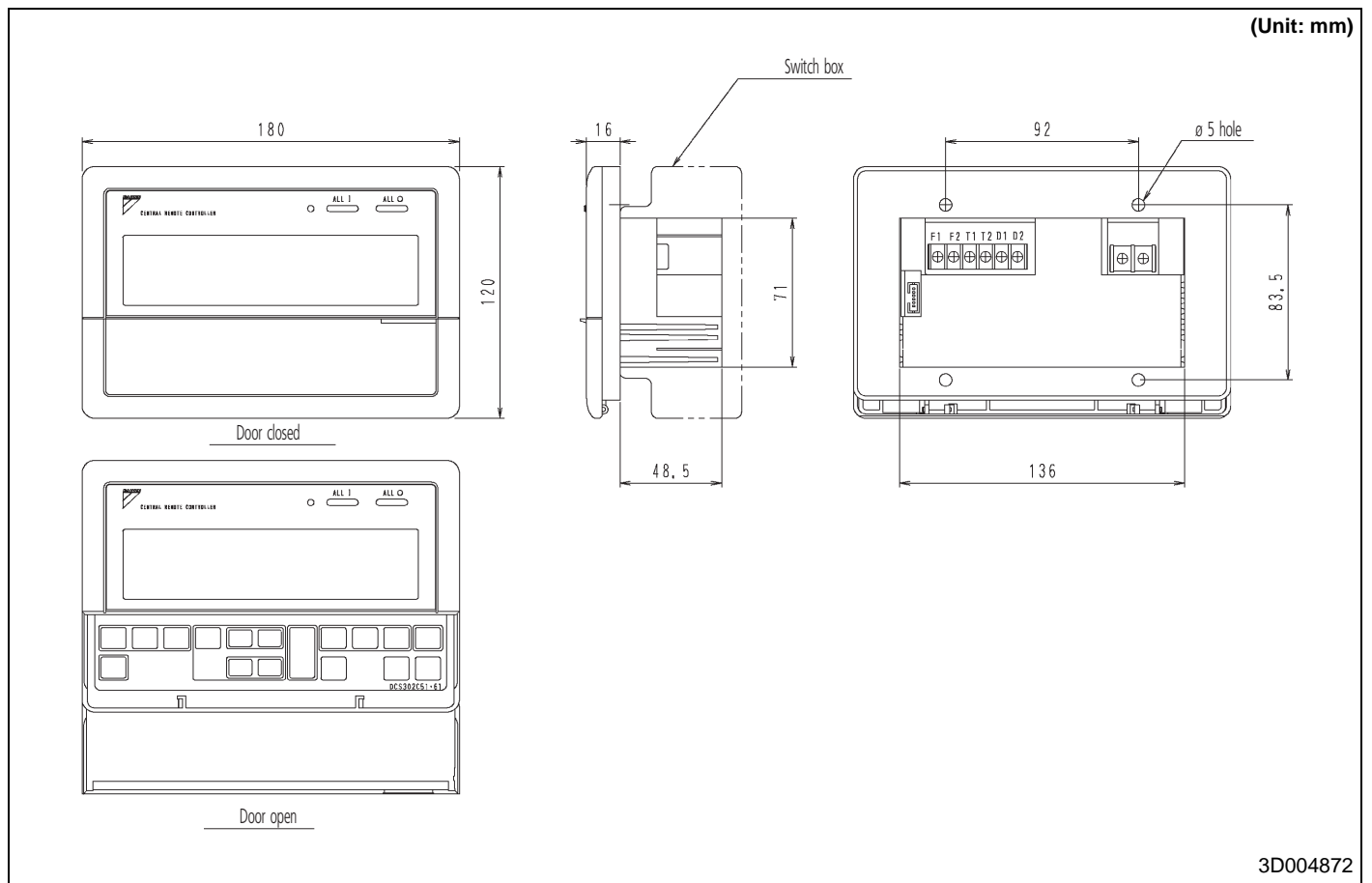

2 DCS302C51: Centralised remote control

2 - 2 Explanation of buttons and functions

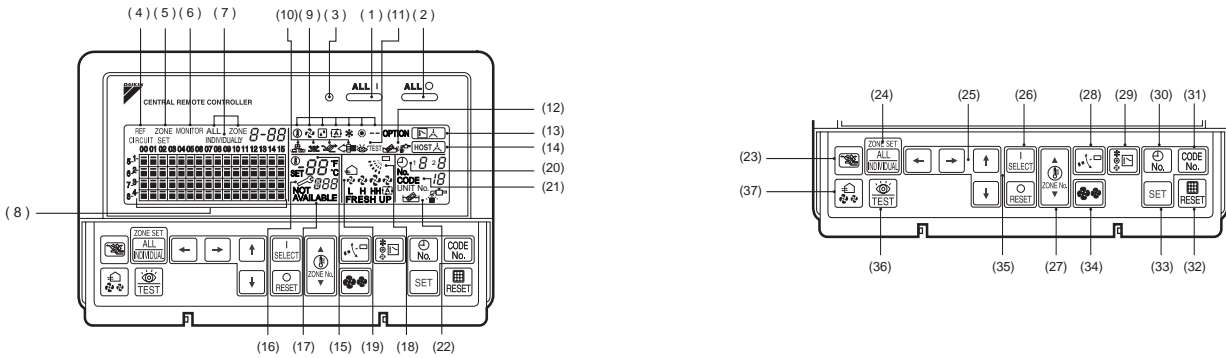

32	FILTER SIGN RESET BUTTON	36	INSPECTOR/TEST RUN BUTTON (FOR SERVICE)
	This button is pressed to erase the "clean filter" display after cleaning or replacement.		Pressing this button scrolls through "inspection", "test run", and "system display". This button is not normally used.
33	SET BUTTON	37	VENTILATION STRENGTH ADJUSTMENT BUTTON
	Sets control mode and time No.		This button is pressed to switch the ventilation strength ("fresh up") of the total enthalpy heat exchanger.
34	FAN STRENGTH ADJUSTMENT BUTTON		
	Pressing this button scrolls through "weaded", "strong", and "fast".		
35	ZONE SETTING BUTTON		
	Zone registration mode can be turned on and off by pressing the start and stop buttons simultaneously for at least four seconds.		

NOTES

- 1 Please note that the display shows all indications for the purpose of explanation only. This is contrary to actual running situations.
- 2 If the unit is used in conjunction with other optional centralised control systems, the operation lamp of the unit that is not under operation control may light up and go out a few minutes behind schedule. This shows that the signal is being exchanged, and does not indicate any failure.

3 DCS301B51: Unified on/off control

3 - 1 Dimensional drawing

2

3

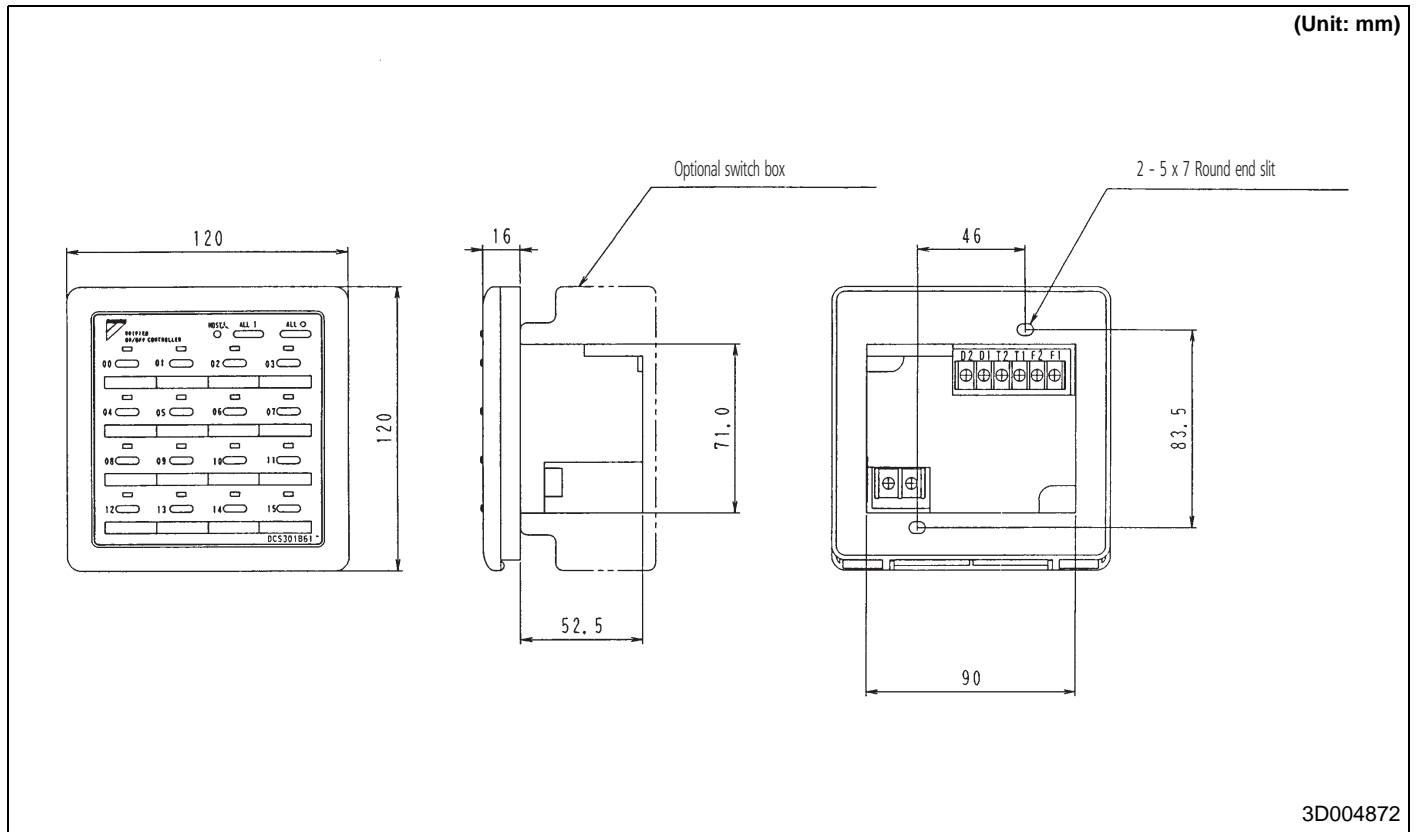

4 DST301B51: Schedule timer

4 - 1 Dimensional drawing

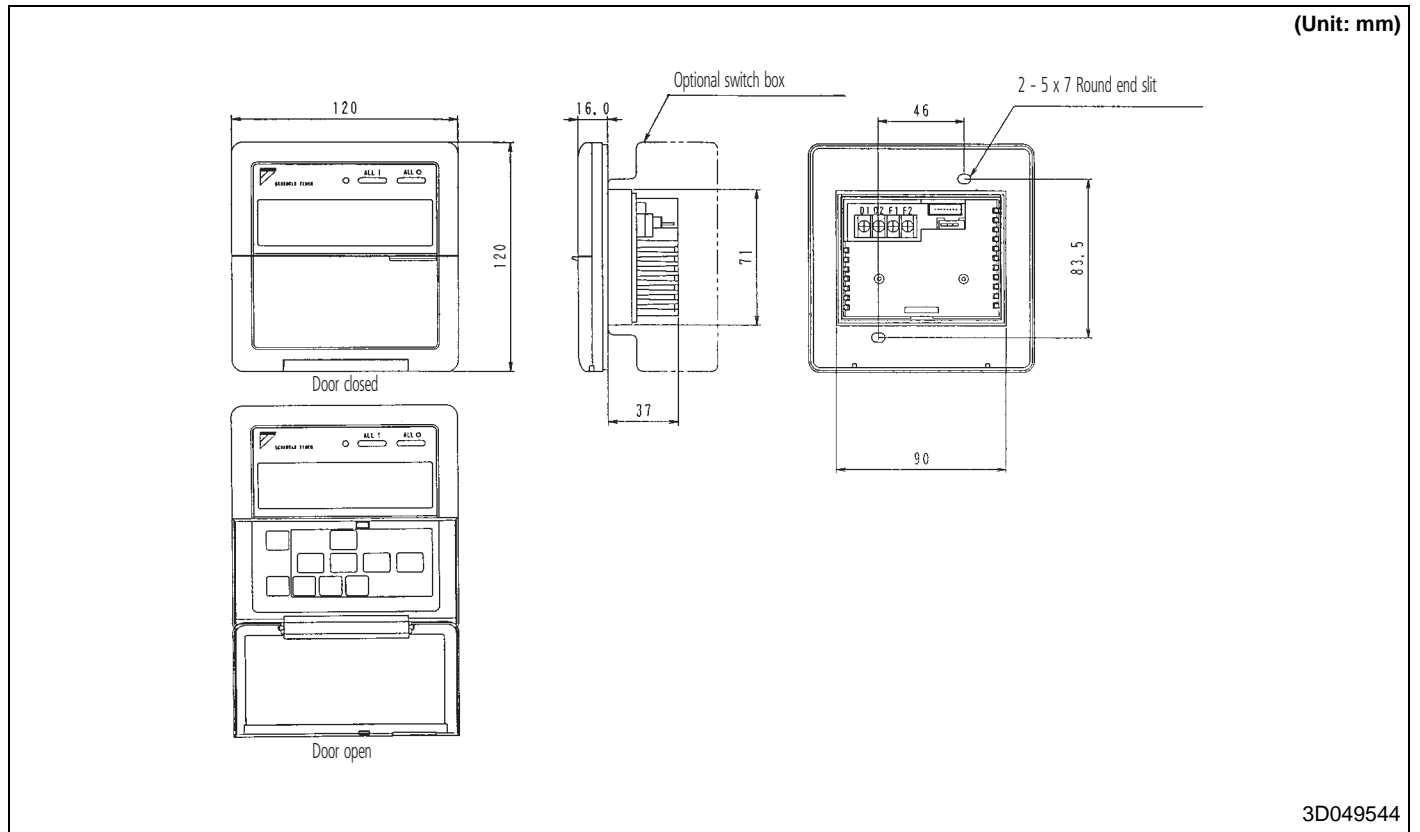

4 DST301B51: Schedule timer

4 - 2 Explanation of buttons and functions

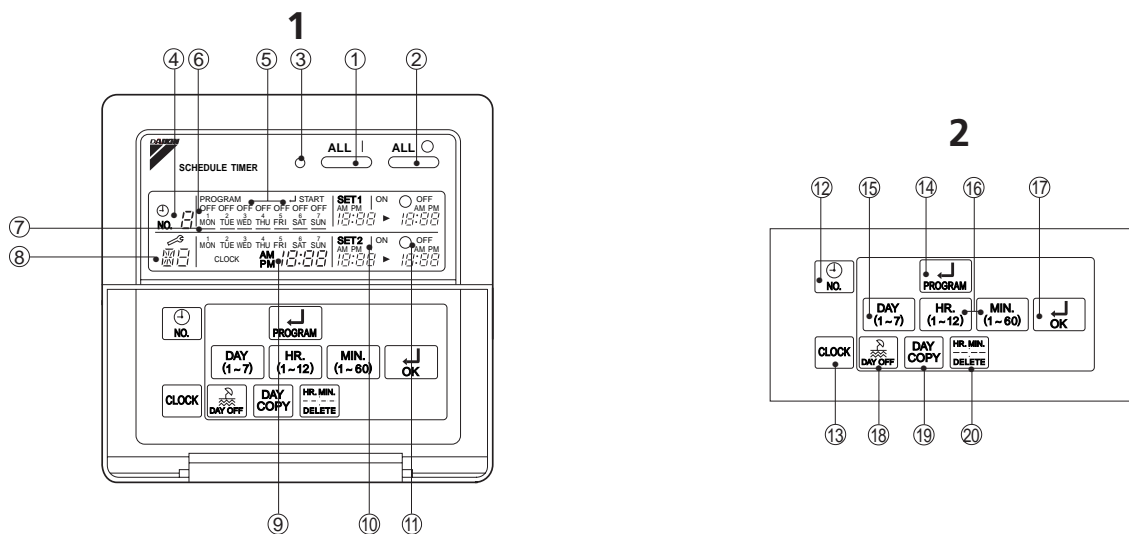

1	UNIFIED OPERATION BUTTON	11	DISPLAY "OFF" (PROGRAMMED TIME OF SYSTEM OFF)
	Press this button to perform the unified operation regardless of the No. of programmed time.		Displays the time programmed to stop.
2	UNIFIED STOP BUTTON	12	TIME NO. BUTTON
	Press this button to perform the unified stop regardless of the No. of programmed time.		
3	OPERATION LAMP (RED)	13	CLOCK ADJUSTING BUTTON
	The light turns on during the operation of the indoor unit.		Press this button to set the present time.
4	"NO." DISPLAY (TIME NO.)	14	PROGRAMMING START BUTTON
	Displays the time No. only when used in conjunction with the centralised remote control.		Press this button to set or check the No. of programmed time. Press it again after you are through with the program.
5	DISPLAY "PROGRAM" (PROGRAMMING START)	15	BUTTON FOR SELECTING DAYS OF A WEEK
	The light turns on when the timer is programmed.		Setting is not possible while this display is being displayed.
6	DISPLAY "OFF" (HOLIDAY SETTING)	16	HOUR/MINUTE BUTTON
	Lights above the day of the week set as holiday. The operation controlled by timer is not available on that day.		Press this button to adjust the present time and the programmed time.
7	DISPLAY "—" (SETTING OF DAYS OF A WEEK)	17	TIMER ON BUTTON
	Flashes below the day of the week programmed.		Press this button to set the present time and the programmed time.
8	DISPLAY "E" (MALFUNCTION CODE)	18	HOLIDAY SETTING BUTTON
	Displays the contents of malfunction during the stop due to malfunction.		Press this button to set holidays.
9	DISPLAY "MÓN TUE WED THU FRI SAT SUN" (PRESENT TIME)	19	BUTTON FOR COPYING PROGRAM OF PREVIOUS DAY
	Displays the present day of the week and time.		Use this button to set the No. of programmed time same as that of the previous day.
10	DISPLAY "MÓN TUE WED THU FRI SAT SUN" (PROGRAMMED TIME OF SYSTEM START)	20	PROGRAM CANCELING BUTTON
	Displays the time programmed to start.		Use this button to set the programmed time to cancel. The display shows "- ; -".

NOTES

- Please note that the display shows all indications for the purpose of explanation only. This is contrary to actual running situations.

5 Survey of various control systems

For more effective localized environmental control Daikin offers various control systems such as single or double remote control or centralized control. This enables the construction of a variety of operational control systems which can be adapted for various uses from remote control to building automation (BA).

Control Method	Objective / use	System outline	Function	Standard number of units
DST301B51 Schedule timer	To carry out weekly schedule operation by 1-minute units	<p>Max. length of transmission wiring for centralised control: 1 km</p> <p>Up to 128 indoor units can be controlled</p> <p>Schedule timer (Power supply for schedule timer)</p>	<ul style="list-style-type: none"> ON/OFF time can be set by units of day, hour and minute; ON/OFF pattern can be set by time zone of twice per day in accordance with application. 	Simultaneously controls 64 groups with one schedule timer. Max. 128 units
Centralised remote control DCS302B51	To control all indoor units from one place	<p>Max. length of transmission wiring for centralised control: 1km</p> <p>Up to 64 units by individual control</p> <p>Up to 64 groups (128 units) can be controlled by group control.</p> <p>Single phase, 220~240V power supply</p> <p>Centralised remote control</p> <p>Remote control</p> <p>Remote control</p>	<ul style="list-style-type: none"> Double central control function Function of liquid crystal remote control can be controlled individually for each zone of the indoor unit. Individual/ unified operation Up to 8 patterns can be set for operation controlled by programmed time when used in combination with schedule timer. Temperature setting for each zone Control operation for each room during centralized control Remote control operation rejected command Sequential start function 	Controls up to 64 groups with one centralised remote control. Max. 128 units
Unified ON/OFF control DCS301B51		<p>Max. length of transmission wiring for centralised control: 1 km</p> <p>Up to 16 units by individual control</p> <p>Up to 16 groups (128 units) can be controlled by group control.</p> <p>Single phase 220~240 V power supply</p> <p>Unified ON/OFF control</p> <p>Remote control</p> <p>Remote control</p>	<ul style="list-style-type: none"> Double central control function Indoor unit ON/OFF control Individual/unified operation Remote control operation rejected command. (Centralised remote control given priority when used in combination with centralised remote control.) Sequential start function 	Controls up to 16 groups of indoor units with one unified ON/OFF control. Max. 128 units
<ul style="list-style-type: none"> Schedule timer Centralised remote control Unified ON/OFF control 		<p>Schedule timer</p> <p>Centralised remote control</p> <p>Combination of up to 8 unified ON/OFF controls possible</p> <p>Up to 128 units by individual control</p> <p>Up to 64 groups (128 units) can be controlled by group control.</p> <p>Single phase, 220~240V power supply</p> <p>Remote control</p> <p>Remote control</p>	<ul style="list-style-type: none"> Respective functions of schedule timer, centralised remote control and unified ON/OFF control are possible. (Control mode of centralised remote control is given priority for operation of remote control for indoor unit.) Sequential start function. 	Controls up to 64 groups of indoor units with 1 schedule, timer, 2 centralised remote controls and 8 unified ON/OFF controls.

6 Wiring example of centralised control systems

- Be sure to connect the wiring of the central controller to (A) or (B).
(Connect to (B), if it is possible.)
- Be sure to limit the number of indoor units within the limitation for each system.
- Never connect the wire between the controllers, that are connected to different circuits.
- In order to prevent the connection of 3 wires on the same terminal, connect to the terminal unit of (A) or (B), or use the relay terminal (local supply).

2
6

Pattern 1

Pattern 2

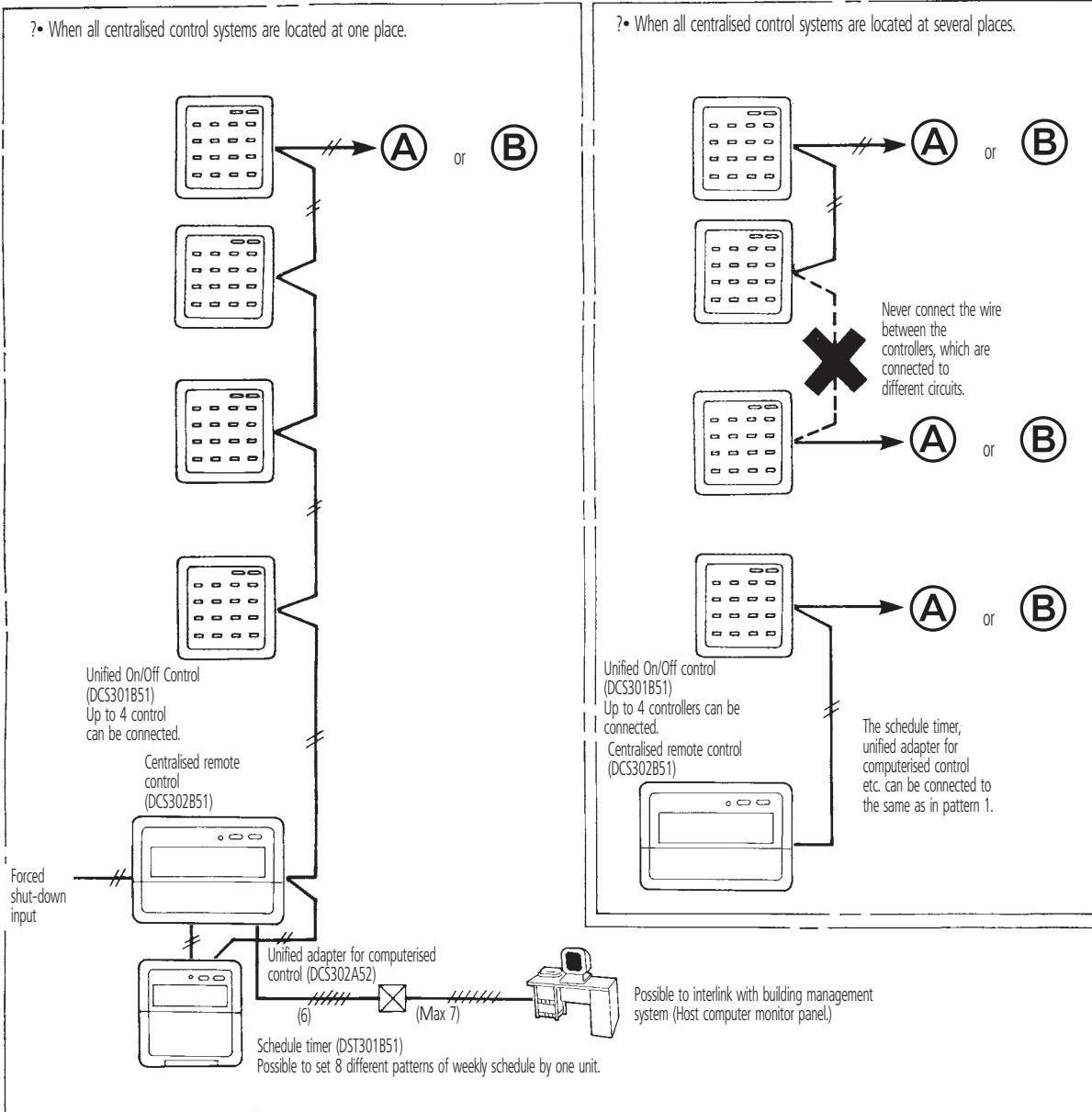

6 Wiring example of centralised control systems

- The longest wiring extension should not exceed 1,000 m.
(Total wiring length should not exceed 2,000 m, excluding the wiring to the remote control).
- Up to 128 indoor units can be controlled.

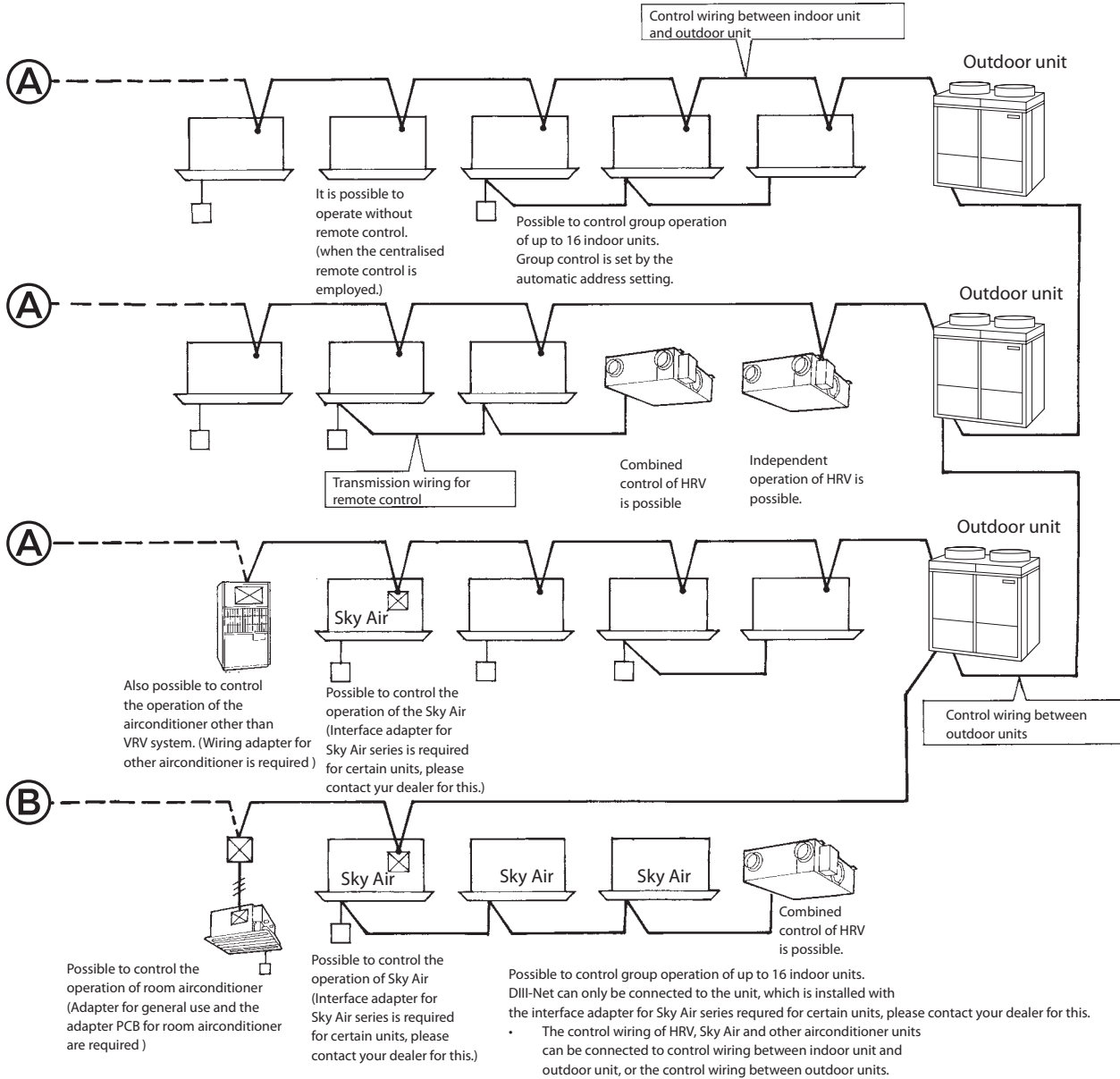

Advantages when central controllers are connected to **B**.

- If the central controllers are connected to (B), it is still possible to have centralised control, even if the power supply of other circuit connected to the central controller is shut-off. (Even if the power is shut off due to long vacation etc.)

7 Length of transmission wiring

The super wiring system, that integrates the control wiring between indoor unit and outdoor unit and the transmission wiring to the central controllers into one common wiring, should satisfy the following limitation.

- The longest wiring extension: Not exceeding 1,000 m
- Total wiring length: Not exceeding 2,000 m

2
7

7 - 1 Wiring example

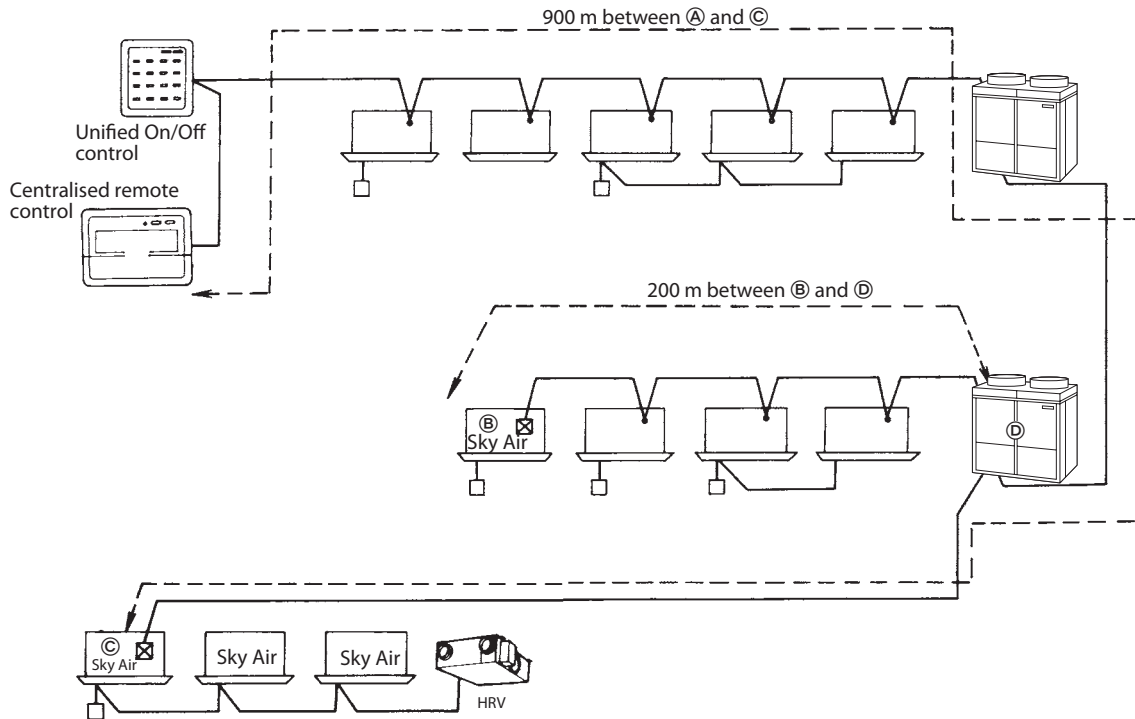

In the above system, the longest wiring extension is 900 m between A and C, which satisfies the limit of 1,000 m. The total length is 1,100 m, that is the total of 900 m between A and C and 200 m between B and C, which also satisfies the limit of 2,000 m. The central controller functions properly, only when both the longest extension and the total length of wiring satisfies the limitation, as shown above.

NOTES

- 1 When designing the system, be sure to check both the longest extension and the total wiring length. If it exceeds the limitation, there is no other way but to split into several systems.

7 Length of transmission wiring

7 - 2 System example (1)

- Branch line; line that is diverged from the main line.
- Sub-branch line: line that is diverged from the branch line.

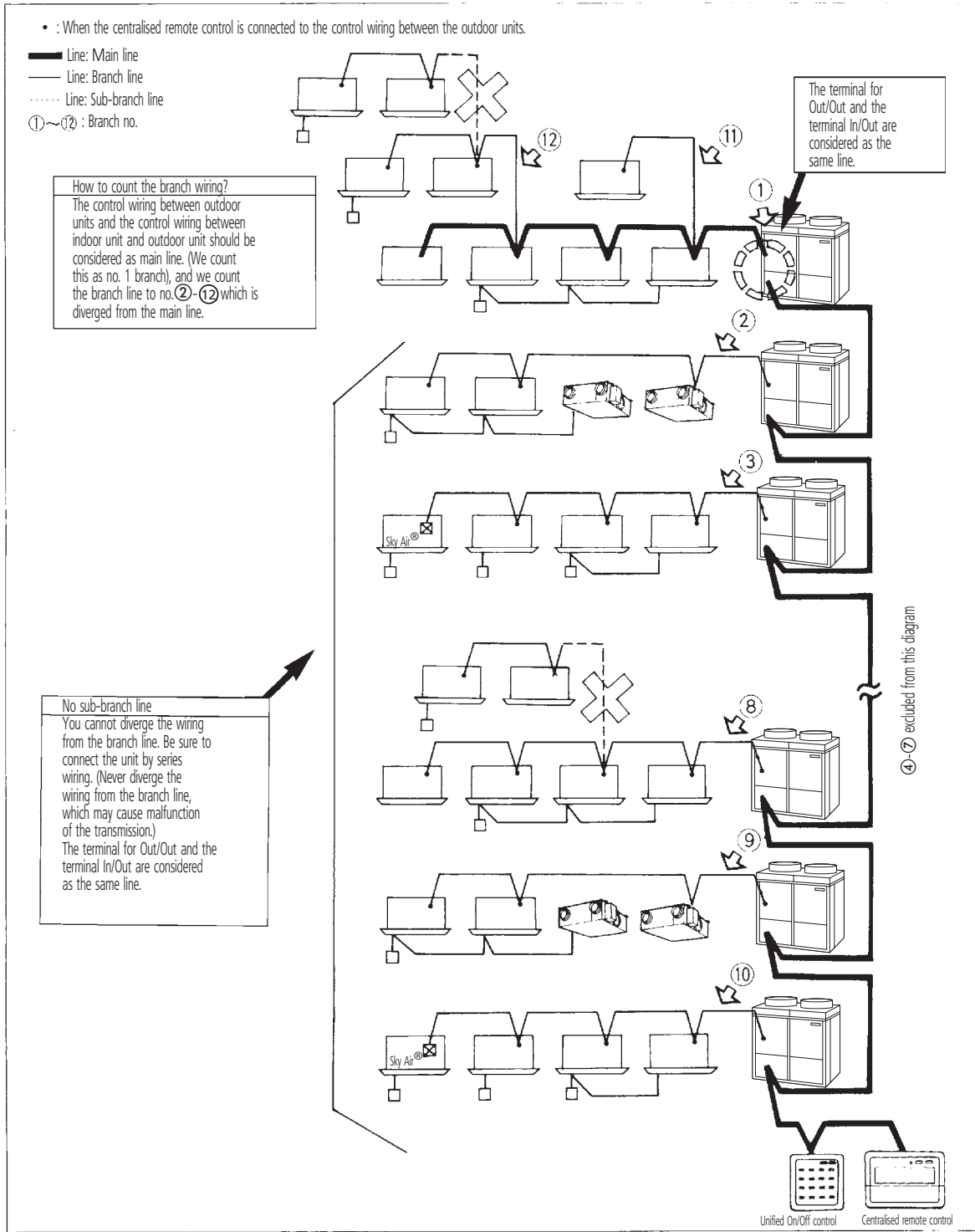

NOTES

- 1 As shown above, the centralised remote controls should be connected to the wiring between the outdoor units, wherever possible. (If connected to the control wiring between indoor unit and the outdoor unit, it may not be able to control the units even on the normal circuit if the circuit connected to the central control is out of order.)

7 Length of transmission wiring

7 - 3 System example (2)

- Branch line; line that is diverged from the main line.
- Sub-branch line: line that is diverged from the branch line.

2
7

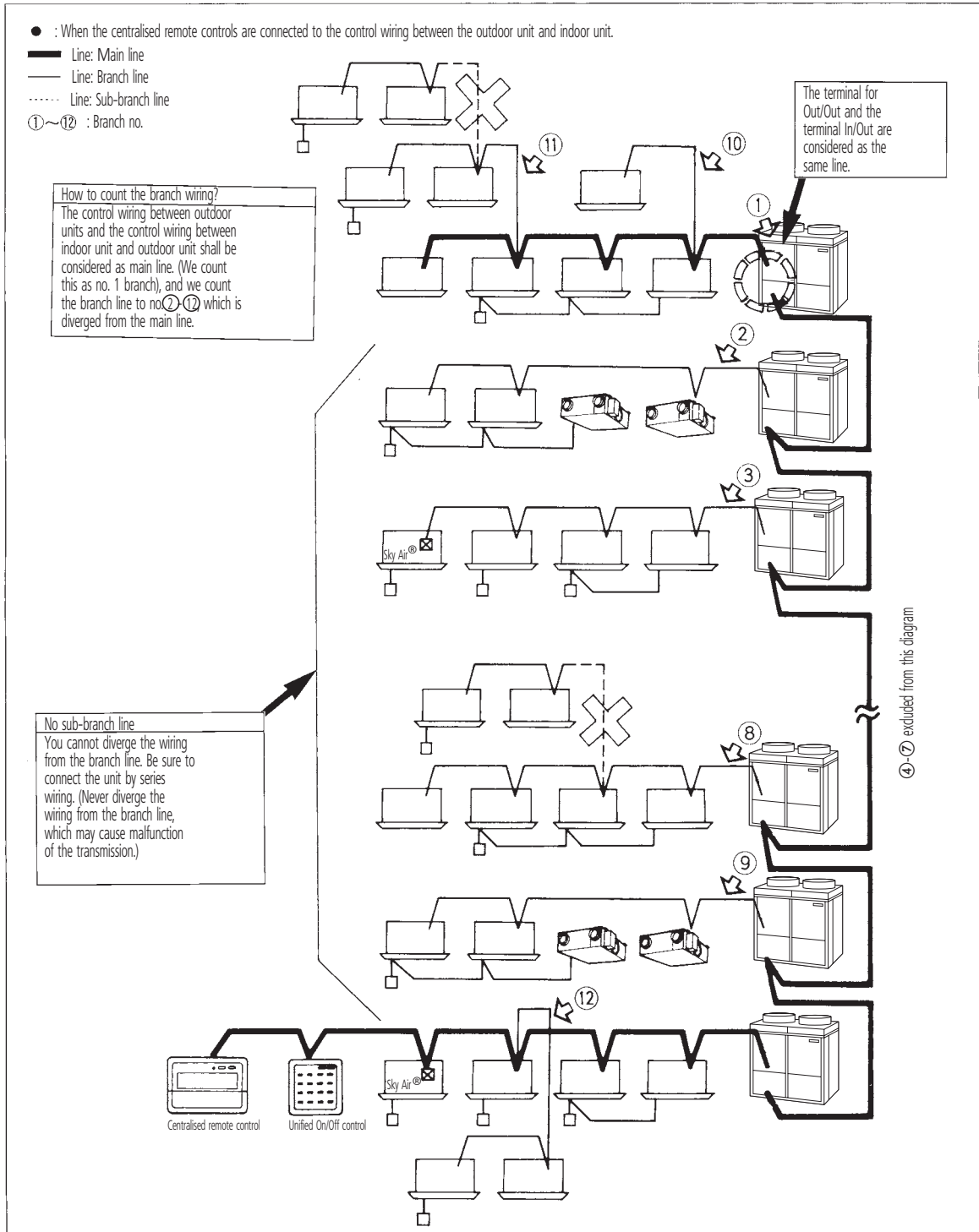

NOTES

- 1 As shown above, if the centralised remote controls are connected to the control wiring between indoor unit and outdoor unit, it may not be able to control the units even on the normal circuit, if the circuit connected to the central controller is out of order. Be sure to connect the central controllers to the control wiring between the outdoor units.

7 Length of transmission wiring

7 - 4 Number of connectable Units

	Central control equipment	Indoor unit	Outdoor unit	Other adapters
Target controller (max. number)	<ul style="list-style-type: none"> Centralised remote control (2 units) Unified ON/OFF control (8 units) Schedule timer (1unit) Parallel interface (4 units) 	<ul style="list-style-type: none"> VRV system Sky Air series (Interface adapter for Sky Air is required for certain units, please contact your dealer for this.) HRV unit Facility air-conditioner (Wiring adapter for other air-conditioner is required.) Room air conditioner (Wiring adapter for other air conditioner is required) BS unit (2) Wiring adapter 	<ul style="list-style-type: none"> Outdoor unit for VRV system 	<ul style="list-style-type: none"> External control adapter for outdoor unit Wiring adapter for electrical appendices
Number of units	(note 1)	Up to 128 units (note 4)	Up to 10 units (note 3)	Up to 10 units

NOTES

1 When you connect 8 or more central control equipment, it is required to satisfy the following conditions. The following conditions are not required to be considered when the number of controller is 7 or less.

- Central control equipment + Indoor units + Outdoor units + other adapters \leq 160 units
 - Central Conversion number of central control equipment * + Indoor units + outdoor units + other adapters \leq 200 units
- NOTE: * is converted one central control equipment except unified ON/OFF control as 10 units.)

- 2 When BS unit is installed, BS unit is not counted in the number. However, the indoor units after BS unit should be counted.
- 3 The outdoor unit is limited up to maximum of 10 units and also the number of function units is also limited up to 5. However, if the sequential start setting is possible, up to 10 function units can be connected.
- 4 When the parallel interface is connected, the number of indoor units is limited up to 64 groups (128 units).
When you judge whether the number of the connectable units is possible, refer to the flow chart on the next page.

7 Length of transmission wiring

7 - 5 Flow chart to determine the number of units to be connected

2
7

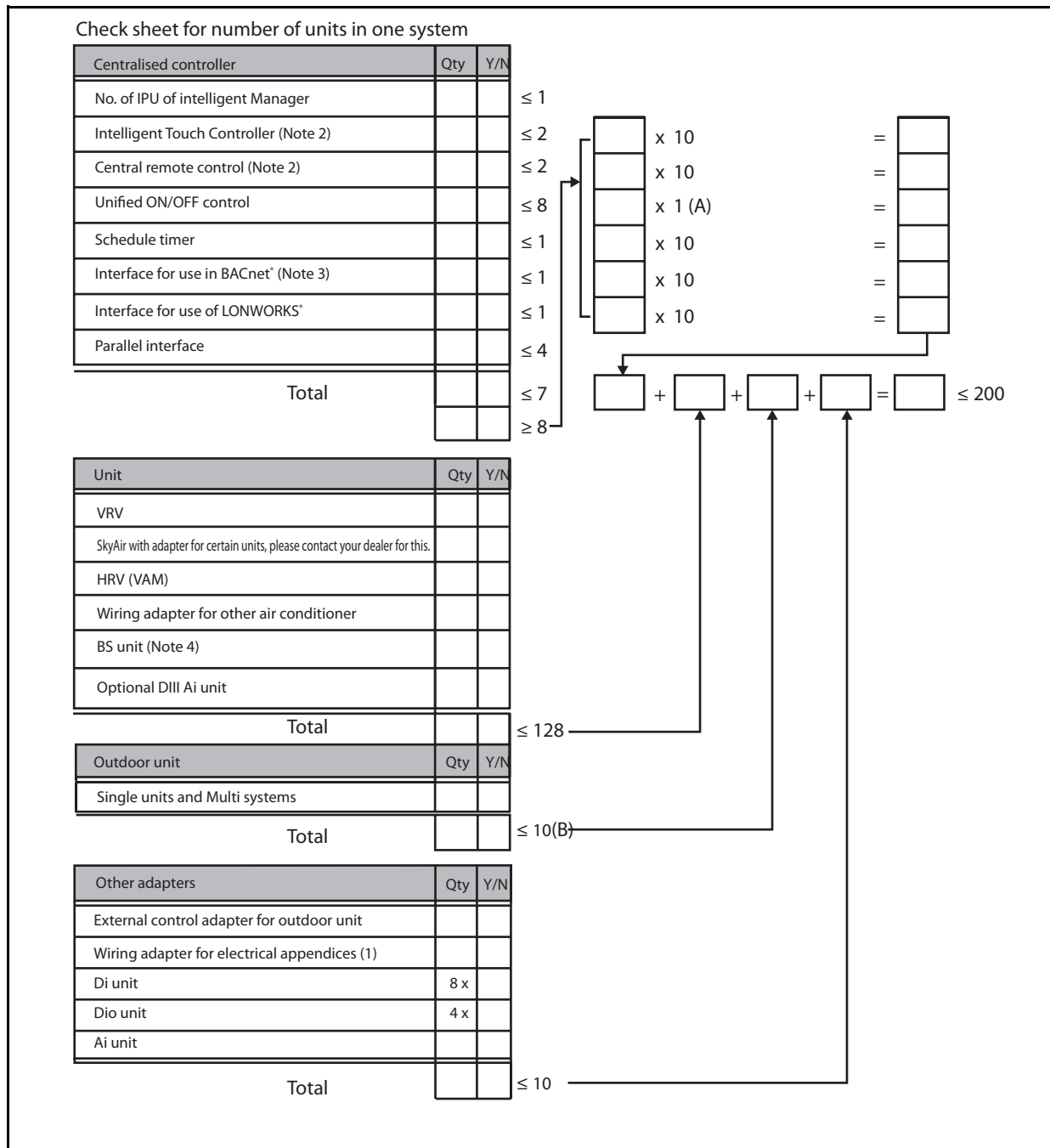

NOTES

1 Condition

(A) means:

- Central control equipment + Indoor units + Outdoor units + other adapters ≤ 160 units
- Conversion number of central control equipment + Indoor units + Outdoor units + other adaptors ≤ 200 units

(B) means:

In case of connecting to DIII-NET

- Outdoor units must be counted to one system even in case of including 3 units. (Master + Master + Master = One system)
- The outdoor units connected by terminal Ex. Q1, Q2 (excepting terminal F1, F2) are regarded as one system.

2 When one system is to be controlled from two locations, up to two intelligent Touch Controller (In case of combining the intelligent Touch Controller and Central Remote Controller, it is restricted to combine two Controllers in total), four Central Remote Controller and 16 unified ON/OFF Controller can be connected. However, the maximum number of units that can be controlled is 128.

3 When a BS unit is used, the indoor units used in its downstream are not counted.

4 One port of one Interface for use in BACnet can have up to 64 groups (64 master indoor units with address). In case of adopting group controlling, the circuit covered by the data station can have up to 128 indoor units including main and sub units.