

humiSonic  
Ultrasound humidifier

**CAREL**

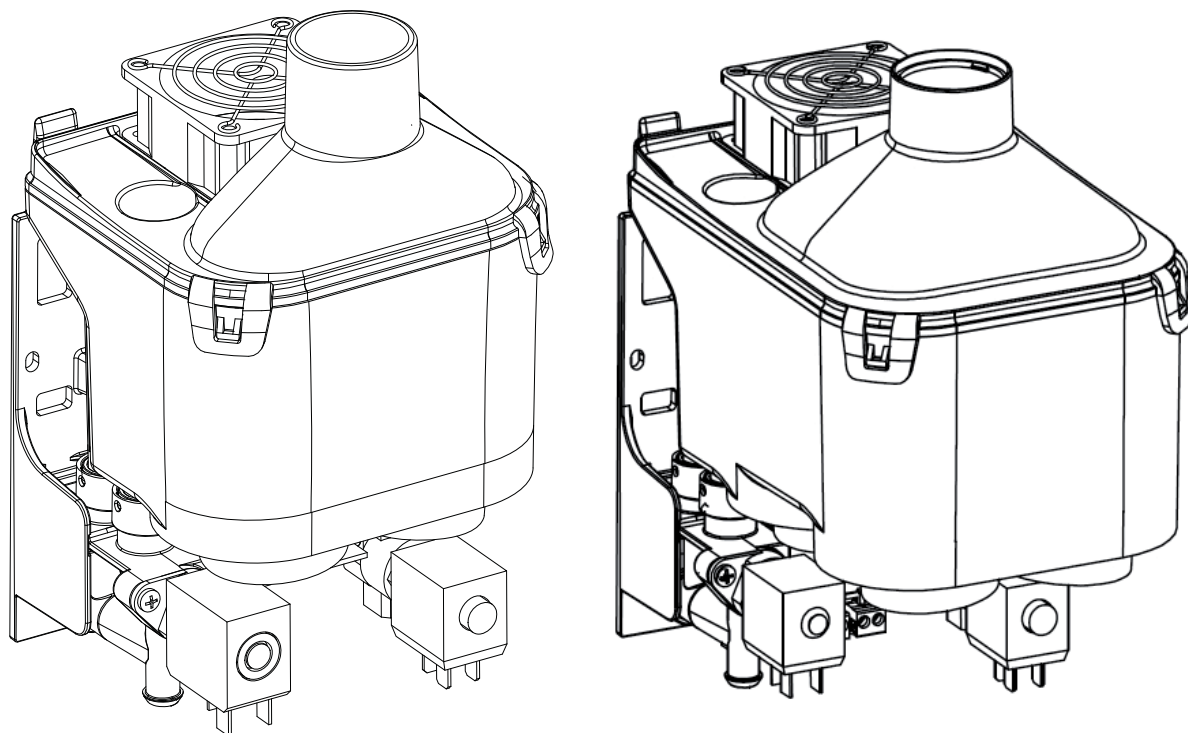

**ENG** User manual

**LEGGI E CONSERVA  
QUESTE ISTRUZIONI**  
**READ AND SAVE  
THESE INSTRUCTIONS**

High Efficiency Solutions



**WARNINGS**



CAREL humidifiers are advanced products, whose operation is specified in the technical documentation supplied with the product or can be downloaded, even prior to purchase, from the website. Each CAREL product, in relation to its advanced level of technology, requires setup/configuration/programming/commissioning to be able to operate in the best possible way for the specific application. The failure to complete such operations, which are required/indicated in the user manual, may cause the final product to malfunction; CAREL accepts no liability in such cases.

The customer (manufacturer, developer or installer of the final equipment) accepts all liability and risk relating to the configuration of the product in order to reach the expected results in relation to the specific final installation and/or equipment. CAREL may, based on specific agreements, act as a consultant for the installation/commissioning/use of the unit, however in no case does it accept liability for the correct operation of the humidifier and the final installation if the warnings or suggestions provided in this manual or in other product technical documents are not heeded. In addition to observing the above warnings and suggestions, the following warnings must be heeded for the correct use of the product:

• **DANGER OF ELECTRIC SHOCK**

The humidifier contains live electrical components. Disconnect the mains power supply before accessing inside parts or during maintenance and installation.

• **DANGER OF WATER LEAKS**

The humidifier automatically and constantly fills/drains certain quantities of water. Malfunctions in the connections or in the humidifier may cause leaks.

**Important:**

- Environmental and power supply conditions must conform to the values specified on the product rating labels.
- The product is designed exclusively to humidify rooms directly.
- Only qualified personnel who are aware of the necessary precautions and able to perform the required operations correctly may install, operate or carry out technical service on the product.
- Only water with the characteristics indicated in this manual must be used for water vapour production.
- All operations on the product must be carried out according to the instructions provided in this manual and on the labels applied to the product. Any uses or modifications that are not authorised by the manufacturer are considered improper. CAREL declines all liability for any such unauthorised use.
- Do not attempt to open the humidifier in ways other than those specified in the manual.
- Observe the standards in force in the place where the humidifier is installed.
- Keep the humidifier out of the reach of children and animals.
- Do not install and use the product near objects that may be damaged when in contact with water (or condensate). CAREL declines all liability for direct or indirect damage following water leaks from the humidifier.
- Do not use corrosive chemicals, solvents or aggressive detergents to clean the inside and outside parts of the humidifier, unless specifically indicated in the user manual.
- Do not drop, hit or shake the humidifier, as the inside parts and the linings may be irreparably damaged.



CAREL adopts a policy of continual development. Consequently, CAREL reserves the right to make changes and improvements to any product described in this document without prior warning. The technical specifications shown in the manual may be changed without prior warning.

The liability of CAREL in relation to its products is specified in the CAREL general contract conditions, available on the website and/or by specific agreements with customers; specifically, to the extent where allowed by applicable legislation, in no case will CAREL, its employees or subsidiaries be liable for any lost earnings or sales, losses of data and information, costs of replacement goods or services, damage to things or people, downtime or any direct, indirect, incidental, actual, punitive, exemplary, special or consequential damage of any kind whatever, whether contractual, extra-contractual or due to negligence, or any other liabilities deriving from the installation, use or impossibility to use the product, even if CAREL or its subsidiaries are warned of the possibility of such damage.

**DISPOSAL**



The humidifier is made up of metal parts and plastic parts. In reference to European Union directive 2002/96/EC issued on 27 January 2003 and the related national legislation, please note that:

1. WEEE cannot be disposed of as municipal waste and such waste must be collected and disposed of separately;
2. the public or private waste collection systems defined by local legislation must be used. In addition, the equipment can be returned to the distributor at the end of its working life when buying new equipment;
3. the equipment may contain hazardous substances: the improper use or incorrect disposal of such may have negative effects on human health and on the environment;
4. the symbol (crossed-out wheeled bin) shown on the product or on the packaging and on the instruction sheet indicates that the equipment has been introduced onto the market after 13 August 2005 and that it must be disposed of separately;
5. in the event of illegal disposal of electrical and electronic waste, the penalties are specified by local waste disposal legislation.

**Warranty on materials:** 2 years (from the date of production, excluding consumables).

**Approval:** the quality and safety of CAREL products are guaranteed by the ISO 9001 certified design and production system, as well as by the mark.



# Content

<b>1. INTRODUCTION AND ASSEMBLY</b>	<b>7</b>	<b>10. WIRING DIAGRAMS</b>	<b>24</b>
1.1 Ultrasound humidifier.....	7	10.1 Diagram .....	24
1.2 Dimensions and weights.....	7	<b>11. GENERAL FEATURES AND MODELS</b>	<b>25</b>
1.3 Opening the packaging .....	7	11.1 Ultrasound humidifier models for fan coils and electrical specifications .....	25
1.4 Positioning .....	7	11.2 Technical specifications.....	25
1.5 Fastening.....	7	<b>12. HUMIDIFIER CONTROL VIA NETWORK</b>	<b>26</b>
1.6 Humidifier assembly.....	8	12.1 Supervisor variable list.....	26
<b>2. WATER CONNECTIONS</b>	<b>9</b>	12.2 Production control via network .....	27
2.1 Supply water .....	9	12.3 Washing cycle activation via network.....	27
2.2 Drain water.....	9	<b>13. OPERATING PRINCIPLES</b>	<b>28</b>
<b>3. ATOMISED WATER DISTRIBUTION</b>	<b>10</b>	13.1 Ultrasound atomisation.....	28
3.1 Atomised water distributor.....	10	13.2 Control principles.....	28
3.2 Fan conveyor.....	10	13.3 Flow-rate modulation.....	28
3.3 Elbow connector.....	10	13.4 Series flow-rate modulation (4-transducer ver. only, dipswitch 8 On).....	29
3.4 Diffuser.....	10	13.5 Automatic insufficient supply water management .....	29
3.5 Filter: 50 micron.....	10	13.6 Automatic control of atomised water production.....	29
3.6 Installation example in fan-coil.....	11	13.7 Automatic control of leaking drain solenoid valve and fill solenoid valve flow-rate .....	29
3.7 Duct installation example (UU01G).....	11		
<b>4. ELECTRICAL CONNECTIONS</b>	<b>12</b>		
4.1 Electrical installation.....	12		
4.2 Power cable connection .....	12		
4.3 Main board connections .....	12		
4.4 Auxiliary card connections (optional).....	13		
<b>5. STARTING, USER INTERFACE AND BASIC FUNCTIONS</b>	<b>14</b>		
5.1 Starting.....	14		
5.2 Shutdown/Standby .....	14		
5.3 Autotest.....	14		
5.4 LED signals.....	14		
5.5 Disabling.....	14		
5.6 Reset tank hour counter .....	14		
5.7 Automatic washing.....	14		
5.8 Washing due to inactivity .....	14		
<b>6. LCD TERMINAL (OPTIONAL)</b>	<b>15</b>		
6.1 Remote display terminal (UUKDI00000) .....	15		
6.2 Meaning of the symbols.....	15		
6.3 Keypad .....	15		
6.4 Main display.....	15		
6.5 Display software release.....	16		
6.6 Accessing and setting parameters .....	16		
6.7 Parameters: Recall default values .....	16		
6.8 Reset hour counter from display .....	16		
<b>7. CONFIGURATION PARAMETERS</b>	<b>17</b>		
7.1 Basic parameters.....	17		
7.2 Advanced parameters.....	17		
7.3 Serial connection parameters.....	21		
7.4 Read-only parameters.....	21		
<b>8. ALARMS</b>	<b>22</b>		
<b>9. MAINTENANCE AND SPARE PARTS</b>	<b>23</b>		
9.1 Spare parts.....	23		
9.2 Tank cleaning and maintenance .....	23		
9.3 Cleaning and maintenance of other components.....	23		



Fig.1 - Packaging

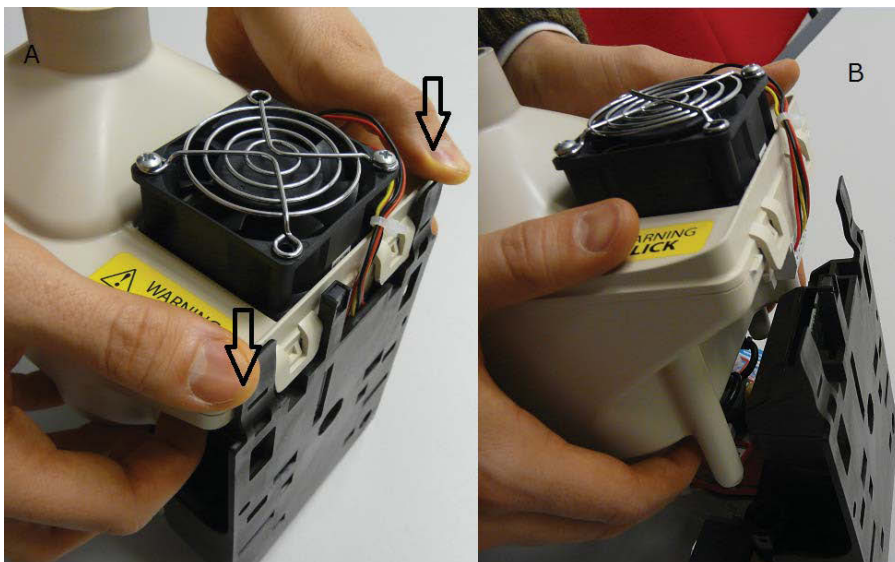

**Note:** before proceeding with the installation, remove the tank from the stand, pushing the fins black as shown.

# 1. INTRODUCTION AND ASSEMBLY

## 1.1 Ultrasound humidifier

Ultrasound humidifiers can be used for vast variety of applications, e.g. data centers, climate rooms, close control units and food preservation, for the RH% control. The 2-transducer version (UU01F) has been specifically developed for integration into fan coils. Atomised water production is 0.5 l/h (UU01F) and 1 l/h (UU01G), delivered directly into the air stream.

## 1.2 Dimensions and weights

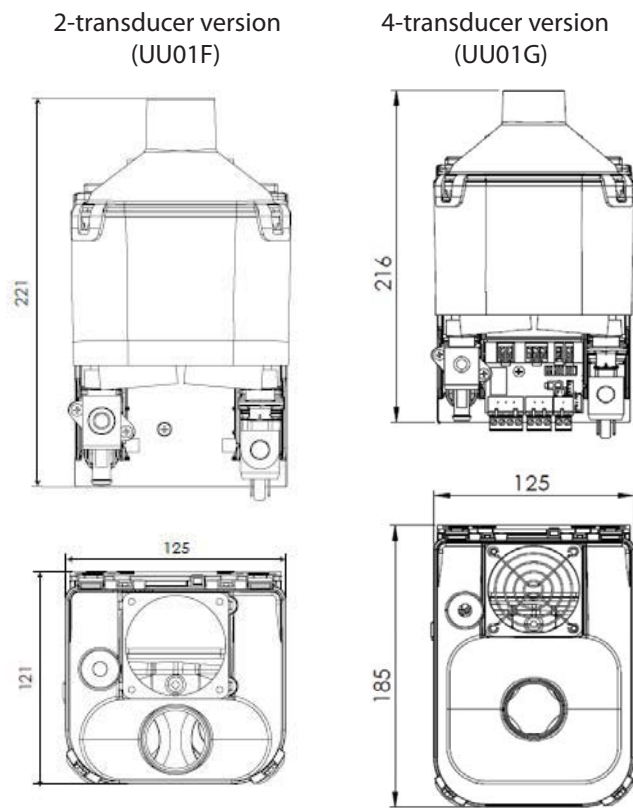

Fig. 1.a

		UU01F	UU01G
dim. mm (")	A	121 (4,76)	185 (7,28)
	B	125 (4,92)	125 (4,92)
	C	221 (8,70)	216 (8,50)
weights kg (lb)	packaged	3,9 (8,60)	5,5 (12,13)
	empty	2,8 (6,17)	4,4 (9,7)

Tab. 1.a

## 1.3 Opening the packaging

- Make sure the humidifier is intact upon delivery and immediately notify the transporter, in writing, of any damage that may be due to careless or improper transport;
- move the humidifier to the site of installation before removing from the packaging, grasping the neck from underneath;
- open the cardboard box, remove the protective material and remove the humidifier,
- The following are contained inside the packaging (fig 1):
  - A: fastening bracket;
  - B: tank;
  - C: fill solenoid valve;
  - D: drain solenoid valve;
  - E: transformer (make sure voltage is correct);
  - F: cable kit.
  - G: terminal kit.

## 1.4 Positioning

- The humidifier may only be accessed by specialist personnel;
- make sure the humidifier is level horizontally, observing the minimum clearance of 20 mm on the sides to leave room for maintenance;
- position the humidifier so as to allow the atomised water to be freely delivered;
- position the transformer in a place that's protected against possible water leaks and in any case not underneath the humidifier.

## 1.5 Fastening

Fastening instructions:

1. make two holes as shown in Fig. 1.b;
2. fix the fastening bracket using two M4x12 screws supplied (see Fig. 1.c), using a spirit level to make sure installation is horizontal;

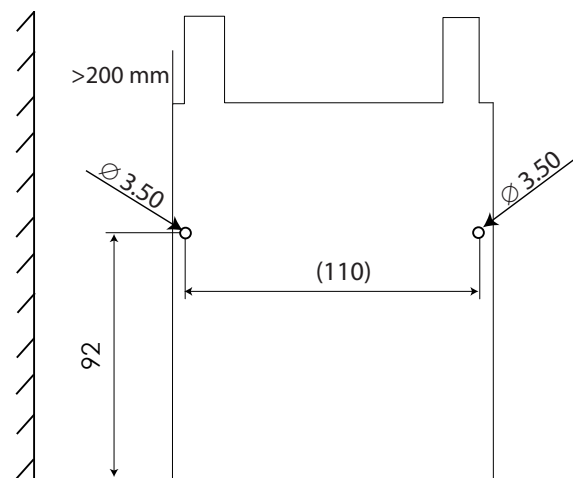

Fig. 1.b

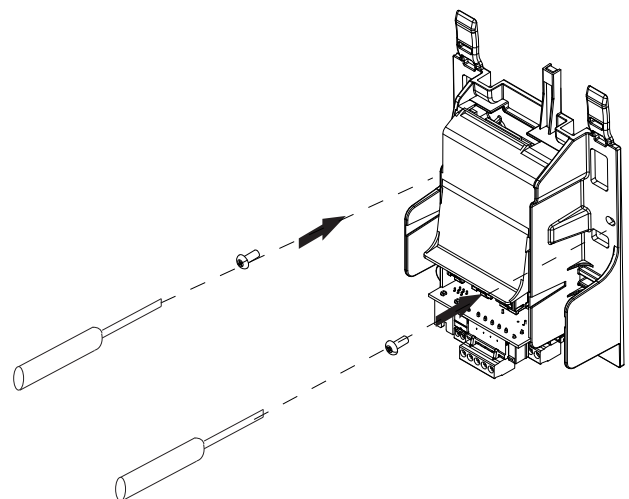
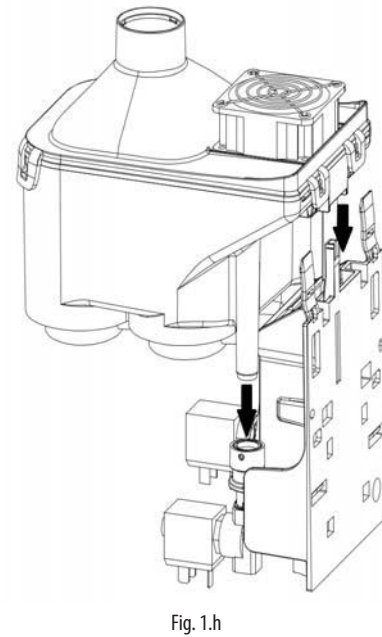
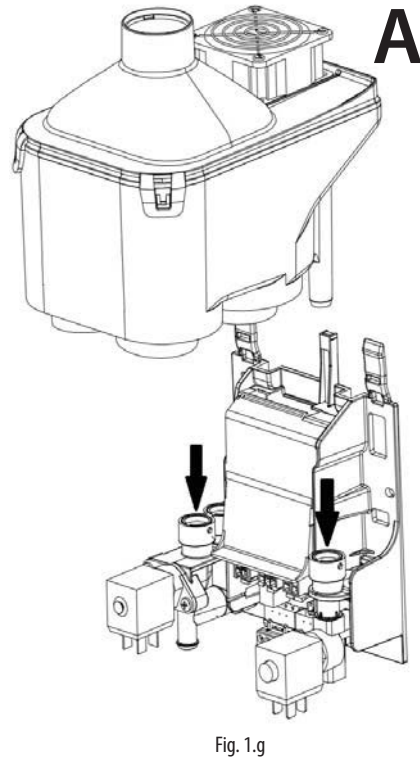
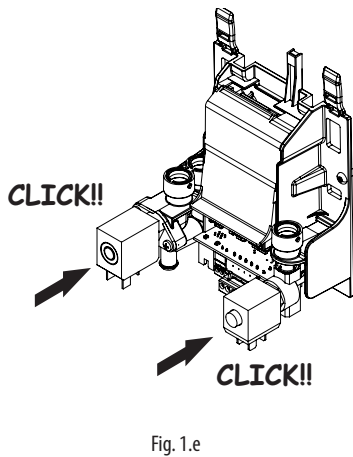
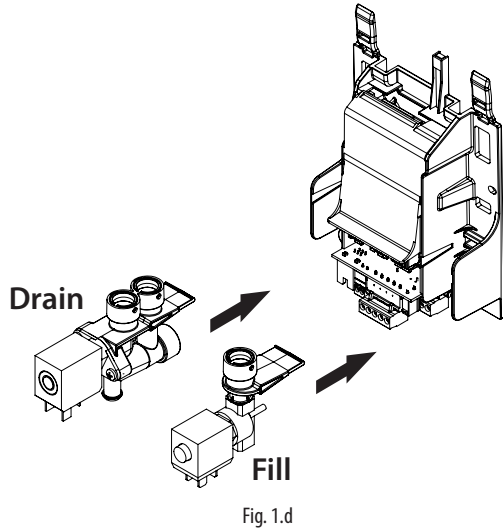

Fig. 1.c

### 1.6 Humidifier assembly

Connect the valves as shown in Figure 1.d and 1.e

**! Important:** insert an o-ring before the drain valve



**! Important:** correct wiring of the ultrasound humidifier is the responsibility of the final appliance manufacturer, as required by IEC EN 60335-1.

- Connect the valve power cable;
- Connect the transformer power cable.

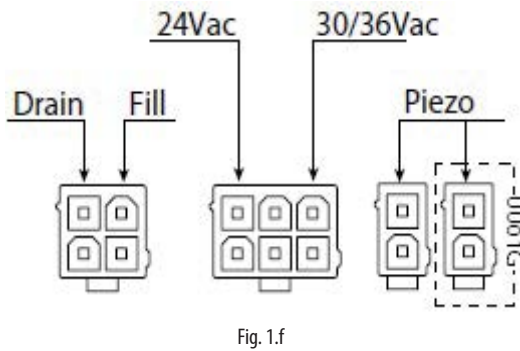

1. Connect the piezoelectric element power cable;
2. grip the tank A with two hands;
3. place the tank vertically on the fastening structure, first aligning the connector on the tank with the electronic board, and then the fill and drain hoses with the corresponding valves;
4. apply pressure vertically until the tank is in position, i.e. the tabs are aligned.

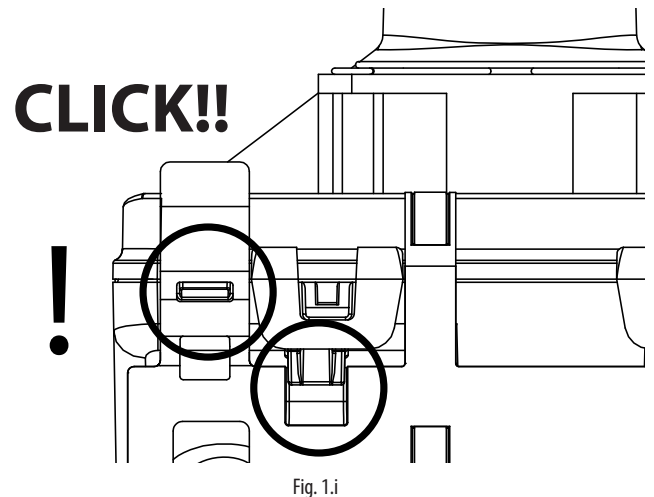



## 2. WATER CONNECTIONS

**⚠ Important:** before proceeding with the water connections, make sure that the humidifier is not connected to the mains power supply.

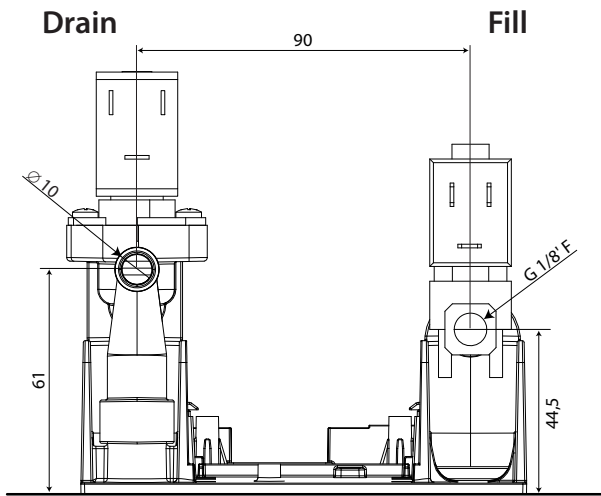

Fig. 2.j  
(bottom view)

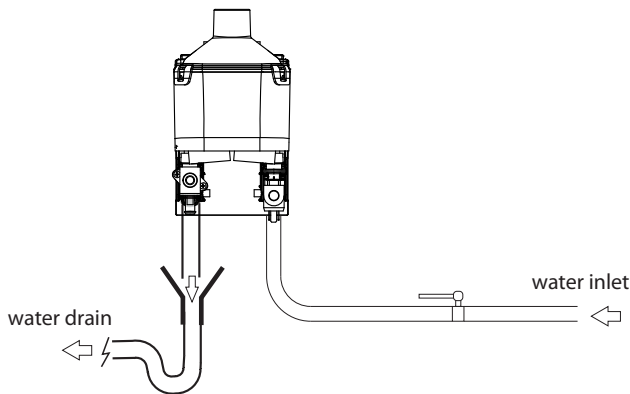

Fig. 2.k

### Water connections (parts not included):



- 1. Install a manual shut-off valve upstream of the installation (so as to shut off the water supply);
- 2. use a hose to connect the humidifier to the water supply (the product is supplied with a slide-on elbow connector);
- 3. install a mechanical filter (60 µS) to trap any solid impurities (connected downstream of the water tap);
- 4. connect a section of drain hose, minimum inside diameter 6 mm;
- 5. prepare a funnel to interrupt continuity in the drain line;
- 6. connect a drain trap to prevent bad odours.

**⚠ Important:** When installation is completed, flush the supply hose for around 30 minutes by piping water directly into the drain, without sending it into the humidifier. This will eliminate any scale or processing residues that may block the fill valve.

### 2.1 Supply water

The ultrasound humidifier works on demineralised water. Using normal water will shorten transducer life; specifically, maintenance intervals for cleaning or replacing transducers depend on to what extent the supply water mineral content exceeds the values recommended in Table 11.b (pg.21). In the case of use of mains water, it is possible a reduction in the production of moisture declared in Table 11.a due to salts and impurities present.

Operating conditions:

- demineralised water with the characteristics indicated in Table 11.b, supply water (p. 21);
- pressure between 0.1 and 0.6 MPa (14.5 and 116 PSI), temperature between 1 and 40 °C (33.8 and 104 °F), G1/8 F connection (see par. 11.2 'Technical specifications');
- no organic compounds.

**⚠ Important:**

- do not add disinfectants or anticorrosive compounds to the water, as these are potential irritants;
- the use of well water, industrial water or water from cooling circuits and, in general, any potentially chemically or bacteriologically contaminated water is prohibited.

### 2.2 Drain water

This is not toxic and can be drained into the sewerage system. (Council Directive 91/271/EEC on Urban Waste Treatment).

### 3. ATOMISED WATER DISTRIBUTION

#### 3.1 Atomised water distributor

**! Important:** the atomised water delivery hose, the distributor, the fan conveyor, the elbow connection and the diffuser are not supplied with the humidifier.

**Requirements:**

- humidifier delivery hose OD 40 mm;
- make sure the atomised water outlet area is 1100 mm<sup>2</sup> (e.g. 22 holes 8 mm in diameter);
- the hose running to the distributor should have a minimum upward gradient of 2° so that any condensate flows back into the humidifier or a special condensate drain system;
- make sure there are no condensate leaks from the water vapour distributor;
- position the distributor in such a way that the air is not directed against nearby objects (minimum distance 10 cm);
- bends or choking of the hose may cause condensate to form and decrease humidity delivery;
- avoid loads that may cause mechanical stress on the humidifier outlet connector.

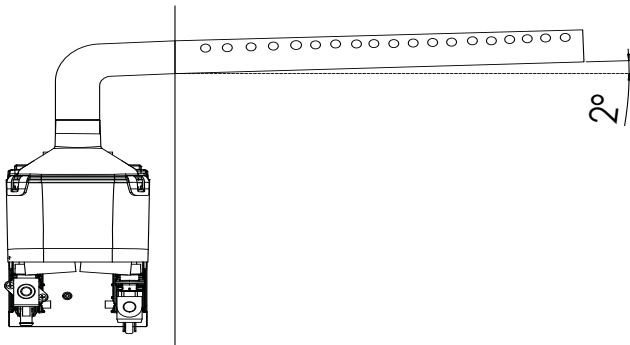

Fig. 3.a

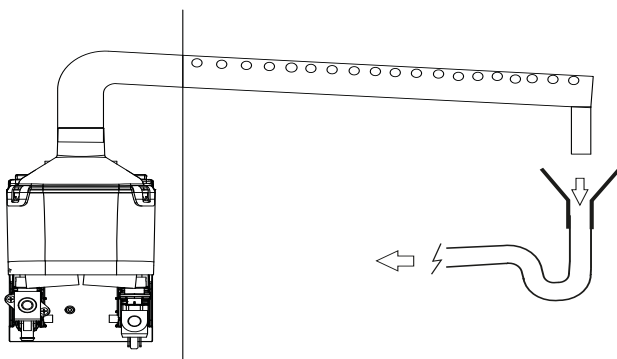

Fig. 3.b

#### 3.2 Fan conveyor

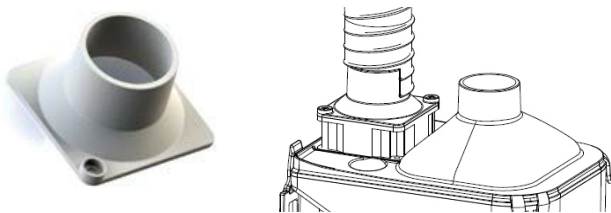

Fig. 3.c

The air flow conveyor can be installed on the top of the fan (removing the protection grill) so as to take in air from a different place to where humiSonic is installed.

#### 3.3 Elbow connector

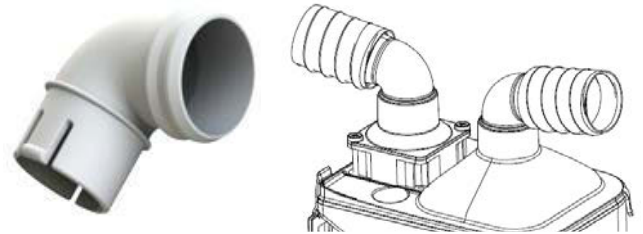

Fig. 3.d

The elbow connector can be installed on the cover and/or the fan conveyor, so as to reduce the overall height occupied by the product.

#### 3.4 Diffuser

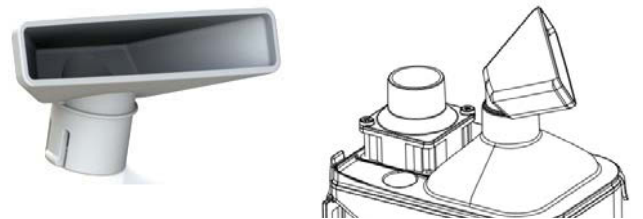

Fig. 3.e

The diffuser can be installed on the cover, so as to deliver atomised water directly into the room.

#### 3.5 Filter: 50 micron

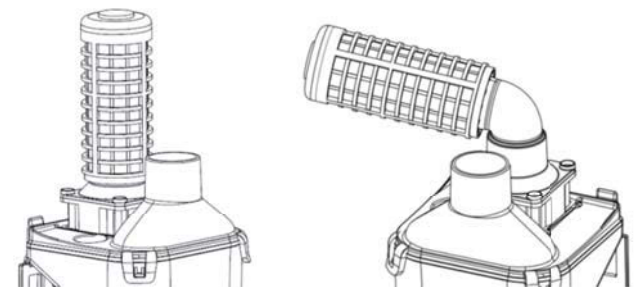

Fig. 3.f

A filter is available to be installed on the fan, using the conveyor (with or without the elbow). The filter is delivered disassembled (cap not fixed) because on one side it is possible to mount it on the conveyor, on the other side on the elbow (to mount with a slight interference). Once mounted, insert the cap. It's necessary to clean the filter (with compressed air or running water) periodically: frequency depends on the environment in which the system is installed. Features filter: 50 micron, H = 13 cm, D = 5 cm

### 3.6 Installation example in fan-coil

Fan coil installation example

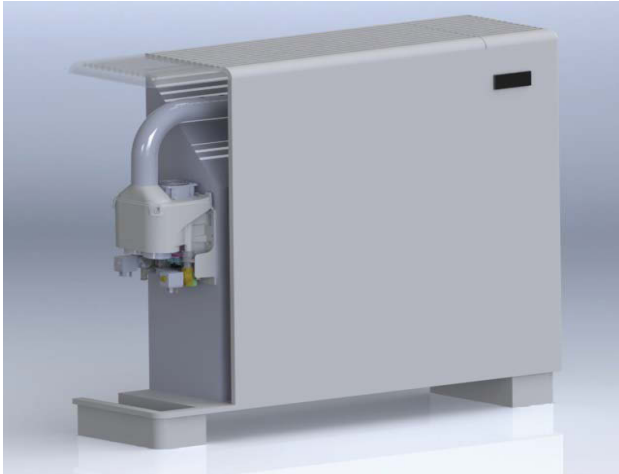

Fig. 3.g

**! Important:** the connections of the hoses for humiSonic air intake and atomised water delivery into the duct must be positioned so as to avoid pressure differences. Excessive unbalances in pressure may cause the system to malfunction, preventing atomised water production. It is preferable to install the system (humiSonic + distribution) on the intake, making sure to leave enough space for absorption. Alternatively, if this is not possible, suggested installation is near the end of the duct, close to the outlet grill (away from the fan, so as to avoid too high pressure).

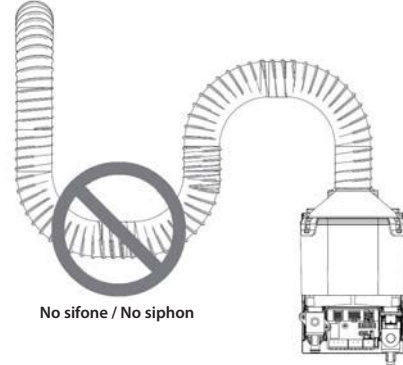

Fig. 3.j

### 3.7 Duct installation example (UU01G)

Duct installation example.

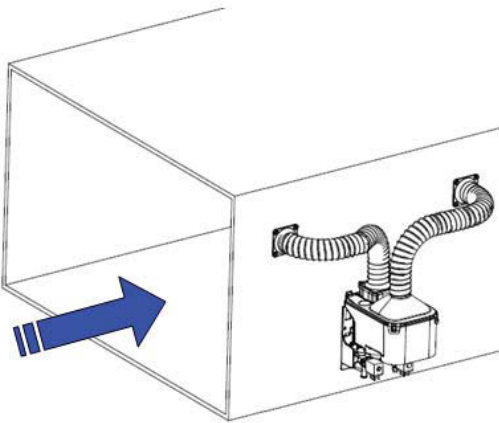

Fig. 3.h

Connect the humiSonic fan inlet to the duct, in a position between the main fan and the connection created for delivering atomised water into the duct.

Carel can supply the fan conveyor (P/N UUKCY00000) to create the connections between the fan, duct and hose (P/N 1312955AXX). The hoses should be as short and as straight as possible (max 1.2m each part), so as to reduce pressure drop.

If using the UUKDPO\*\*00 distribution system in the installation, turn the hose so that the holes are in the direction of air flow (see the figure)



Fig. 3.i

## 4. ELECTRICAL CONNECTIONS

### 4.1 Electrical installation

#### Board connections

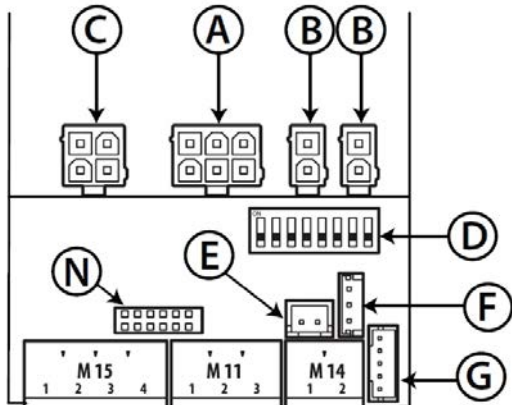

Fig. 4.a

#### Key to Fig. 4.a:

A	board power supply input from transformer (24/36V for 230V transformer or 24/30V for 115V transformer)
B	transducer power cable;
C	valve power cables (L drain / R fill)
D	configuration dipswitch
E	TAM (current transformer) input for measuring current on fan neutral
F	trimmer connection to adjust set point (optional)
G	TH humidity probe connection (IIC digital serial, part no.: HYHU000000) optional.
M14	remote ON/OFF (M14.1-M14.2)
M11	RS485 serial (M11)
M15	- N.O. alarm relay (M15.1-M15.2) - 30 Vdc output (24 Vac rectified , max. 3W) (M15.3-M15.4)
N	auxiliary card connection

Tab. 4.b

**Dipswitch configuration:** configuration must be performed before fitting the tank.

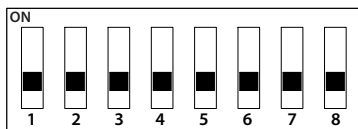

Fig. 4.b

1.	Communication OFF Serial 485 Carel/Modbus ON tLAN
2-3	tLAN address (if 1 is ON) OFF/OFF -- OFF/ON address 1 ON/OFF address 2 ON/ON address 3
4	Serial 485 / tLAN baud rate OFF 19200 ON 9600
5-6	Humidity Setpoint OFF/OFF 50 %rH OFF/ON 30 %rH ON/OFF 40 %rH ON/ON 60 %rH
7	TAM OFF disabled ON enabled
8	Production transducer management (only for 4-transducer version) OFF --> parallel management (modulation of all 4) ON --> if demand is less than 50%, only one pair of transducers operates, alternately

Tab. 4.c

### 4.2 Power cable connection

Correct wiring of the ultrasound humidifier is the responsibility of the final appliance manufacturer, as required by IEC EN 60335-1.

Before performing the electrical connections, make sure that the unit is disconnected from the mains power supply.

Check that the power supply voltage of the appliance corresponds to the value indicated on the rating plate affixed to the side of the product. Connect the transformer output cable to the electronic board (terminal block A in Fig 4.a). Connect the transformer input cable to the mains. The humidifier power line must be fitted with a disconnect switch.

**Note:** avoid unwanted interference, the power cables should be kept separate from the probe signal cables.

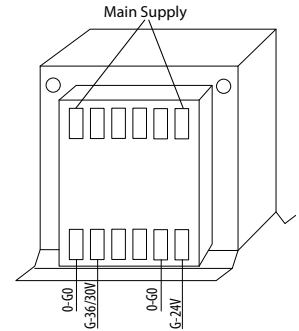

Fig. 4.c

Once the electrical and water connections have been completed, the humidifier is ready for operation.

### 4.3 Main board connections

Depending on the type of signal used, atomized water production can be enabled and/or managed in different ways (ON/OFF or modulating).

**HUMIDOSTAT OR REMOTE CONTACT (ON/OFF action)**

Production is enabled by closing terminal M14.

M14 can be connected to a switch, a humidistat or a controller (voltage-free contact, max 5 Vdc open, max 7 mA closed).

**TH HUMIDITY PROBE (Optional)**

If the TH humidity probe is connected to the G terminal (fig 4.a) atomized water production starts if:

- The terminal M14 is closed;
- The humidity value measured by the probe is below the setpoint (preset at 50%rH and modified via dipswitches 5-6, see Tab.4.a)

The setpoint can be changed by connecting the trimmer (optional) to F terminal (fig 4.a)

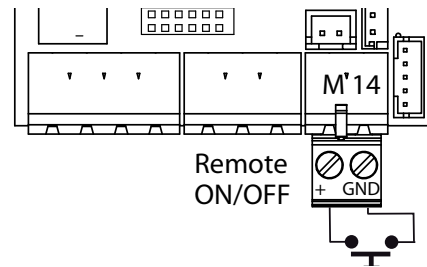

Fig. 4.d

### 485 SERIAL CONNECTION

#### Carel/Modbus protocol

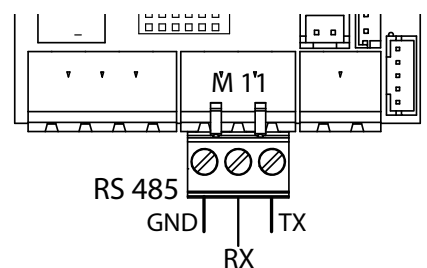

Fig. 4.e

**!** Important: for RS485 connections in household (IEC EN 55014-1) and residential (IEC EN 61000-6-3) environments, use shielded cable (with shield connected to PE both on the terminal and controller ends), maximum length specified by the EIA RS485 protocol, equivalent to European standard CCITT V11, using AWG26 twisted pair cable; the input impedance of the 485 stage is 1/8 unit-load (96 kOhm). This configuration allows a maximum of 256 devices to be connected, with cables in separate conduits from the power cable.

**ALARM RELAY**

This is used to signal one or more alarms via a remote connection.

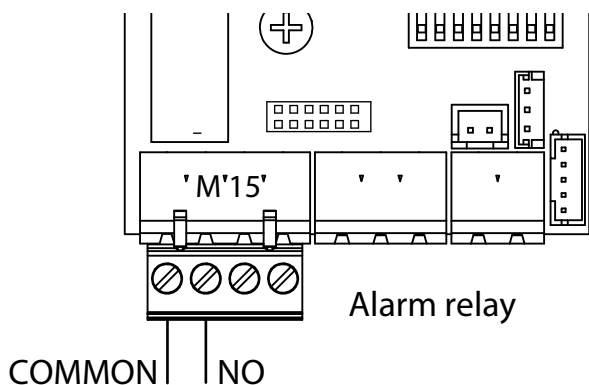

Fig. 4.f

**ALARM RELAY POWER SUPPLY**

The connections shown in Fig.4.g can be used to directly control a light or an auxiliary relay coil 30 Vdc (24 Vac rectified), 3 W max.

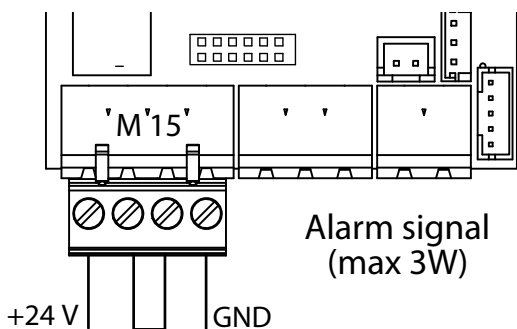

Fig. 4.g

**!** Note: in industrial environments (IEC EN61000-6-2) the signal cables leaving the unit must not exceed 10 m (33 ft)<sup>(1)</sup> in length: remote on/off digital input (terminals M14.1...M14.2) and shielded cable for RS485 communication.

**4.4 Auxiliary card connections (optional)**

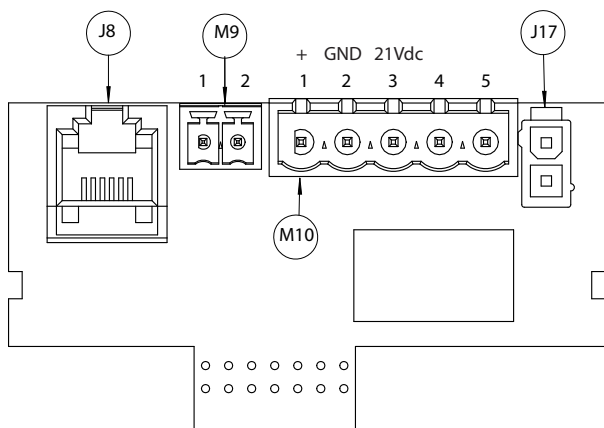

Fig. 4.h

<b>J8</b>	tLAN terminal connection (optional) with 30 Vdc power supply (24 Vac rectified)
<b>M9</b>	tLAN AUX serial connector
<b>M10</b>	M10.1 - + Analogue proportional controller/probe/humid. M10.2 - + GND signal reference M10.3 - +21Vdc for active probe supply M10.4 - N.U. M10.5 - N.U.
<b>J17</b>	AUX input

The auxiliary card features the following connections

ON/OFF CONTROLLER (humidostat or remote switch)

- jumper inputs M14.1 and M14.2 (enable) on the main board;
- connect terminals M10.1 and M10.2 to a humidostat or a remote switch (voltage-free contact)
- set parameter A0=0 to enable On/Off operation (see Chap. 7)

EXTERNAL PROPORTIONAL CONTROLLER (modulating)

- jumper inputs M14.1 and M14.2 (enable) on the main board;
- connect terminals M10.1 and M10.2 (production request) to an external controller;
- set parameter A0=1 to enable modulating control (see Chap. 7) and parameter A2 depending on the chosen signal (0 to 10V, 2 to 10V, 0 to 20, 4 to 20 mA) (see Chap. 7).

CONTROL WITH CAREL HUMIDITY PROBE

- jumper inputs M14.1 and M14.2 (enable) on the main board;
- connect the probe to terminals M10.1, M10.2. The power line M10.3 can be connected with cable of maximum length of 2 m (6,6 ft); for greater lengths use an external power supply with the signal earth electrically connected to the signal earth of the controller.
- set parameter A0=2 to enable probe control (see Chap. 7) and parameter A2 depending on the chosen signal (0 to 10V, 2 to 10V, 0 to 20, 4 to 20 mA) (see Chap. 7).

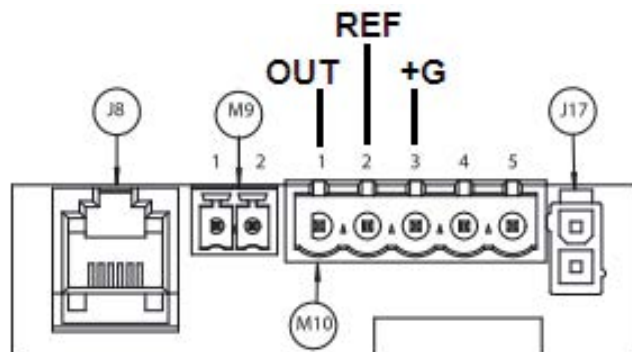

If non-CAREL probes are used, check:

- voltage signal: 0 to 10 Vdc, 2 to 10 Vdc, terminal M10.1 (GND: M10.2);
- current signal: 4 to 20, 0 to 20 mA, terminal M10.1 (GND: M10.2).

**Final checks**

The following conditions represent correct electrical connection:

- mains power to the humidifier corresponds to the voltage shown on the rating plate;
- a mains disconnect switch has been installed so as to be able to disconnect power to the humidifier;
- terminals M14.1, M14.2 are jumpered or connected to a contact to enable operation;
- if the humidifier is controlled by an external controller (with auxiliary card), the signal earth is electrically connected to the controller earth.

## 5. STARTING, USER INTERFACE AND BASIC FUNCTIONS

Before starting the humidifier, check:



- water connections: chap. 2, in the event of water leaks, do not start the humidifier before having restored the connections;
- water vapour distribution: chap. 3 and electrical connections chap. 4.

### 5.1 Starting

- 1 The humidifier, once powered and enabled for production (remote on-off/humidistat, terminal M14, Fig 4.e), is ready for operation.
- 2 If there are no other external connections, the humidifier will start, and operation will only stop if the enabling signal (M14) is no longer present.
- 3 If TH humidity probe (optional) is connected to terminal G (Fig. 4.a), the humidifier will operate until reaching the humidity set point (default 50%RH). See chap. 12.9.
- 4 If terminal E (Fig. 4.a) is connected to the current transformer (TAM, optional) and is enabled (dipswitch 7, Fig. 4.c) the humidifier will only start if current is measured on the fan neutral wire on the principal system. This wire must run inside the TAM. In this way, atomised water will only be produced when the fan is on.

### 5.2 Shutdown/Standby

- 1 To switch the humidifier off, disconnect power
- 2 The humidifier goes into standby when:
  - the remote on/off contact is open
  - TH probe is fitted and the humidity set point has been reached
  - no current is measured by the TAM (if fitted and enabled)
  - the on/off contact is open and serial enabling is set to 0 (see Chap 12.2)
  - a modulating signal is used (optional card) and there is no request

When the humidifier is in standby, the unit is emptied automatically. When in standby the fan stays on for 5 min.

### 5.3 Autotest

Whenever the humidifier is first started (from off), if enabled and humidity production is required, a test cycle is run. A complete fill and drain cycle is performed, during which the level sensor is monitored; if the test is successful, regular water vapour production will start. If the test fails, production is disabled (see the alarm table).

### 5.4 LED signals

A light is fitted on the top of the humidifier to indicate operating status:

	GREEN LED	ORANGE LED
Steady	Humidity production	Retry procedure**
Flashing slowly*	Set point reached	Standby
Flashing quickly*	Fill or Autotest	Washing

\*Flashing slowly: 1s ON and 1s OFF  
 Flashing quickly: 0.2s ON and 0.2s OFF

\*\*See paragraphs 13.5 and 13.6.

The red LED means an alarm is active. See chapter 8 for information on alarms.

### 5.5 Disabling

The humidifier can be disabled in three different ways:

- Opening contact M14.1 and M14.2 (enabling signal)
- If the current transformer (TAM) is fitted and enabled (dipswitch 7 ON) and no current is measured
- There are active alarms (see Chap. 8)

### 5.6 Reset tank hour counter

The humidifier is fitted with an hour counter that records operation. After a set number of hours (1500), a signal is activated to indicate maintenance should be performed on the tank and operation of the piezoelectric elements checked (see Chap.9 "Maintenance and spare parts" on p. 19 and chap. 8 "Alarm table" on p. 18)

To reset the hour counter at any time, proceed as follows:

- Switch the humidifier off
- Wait for the tank to empty completely
- Close the water supply tap
- Remove the tank, making sure to disconnect the piezoelectric element power supply
- Open the On/Off contact
- Switch the humidifier on WITHOUT THE TANK. The yellow LED will flash
- Close the On/Off contact, the yellow LED will remain on steady
- Switch the humidifier off
- Reposition the piezoelectric element connector, replace the tank and open the water supply tap
- Switch the humidifier on

### 5.7 Automatic washing

The humidifier automatically runs a washing cycle at intervals in operating time set by parameter b8 (default 60 minutes, parameter b0 can be used to convert this value into hours, see Table 7.c).

The washing cycle involves a complete drain cycle, a phase in which fill and drain are activated together (default 1 minute, parameter b3) to flush out any residues in the tank, a complete fill cycle and finally another complete drain cycle.

During this operation, water vapour production is stopped.

### 5.8 Washing due to inactivity

If the humidifier remains inactive (on but in standby) for an extended period (parameter b2, default 24 hours) a washing cycle is performed, as described in the previous paragraph. This cleans the tank of any residues (e.g. dust) that may have accumulated during the period of inactivity. Parameter b0 can be used to set the time when this washing cycle is performed. By default, the washing cycle is run after 24 hours (continuous) of no operation, i.e. the humidifier is in standby. This is because the humidifier is normally connected to a reverse osmosis system, which needs to operate frequently in order to avoid malfunctions. B0 (see Table 7.c, reverse osmosis) can be set so that the washing cycle is performed when first restarting after a period of continuous inactivity set by b2.



## 6. LCD TERMINAL (OPTIONAL)

### 6.1 Remote display terminal (UUKDI00000)

The LCD terminal is an option and can only be used if the auxiliary card is fitted, this too an option.

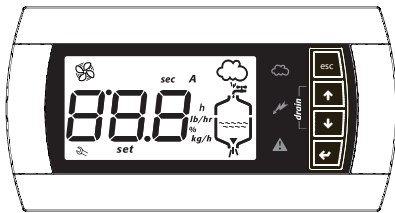

Fig. 6.a

The terminal displays humidifier status and can be used to customise operation by setting the parameters.

#### CONNECTION:

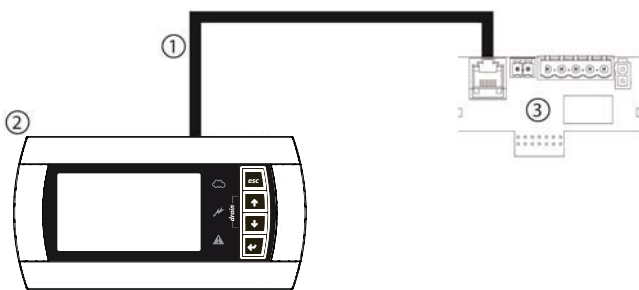

Fig. 6.b

Key:

1	6-wire telephone cable P/N S90CONN000 or equivalent, maximum length 2 m (6,6 ft) <sup>(1)</sup> ;
2	remote display terminal.
3	optional card

<sup>(1)</sup> For lengths exceeding 2 m (6,6 ft), use shielded cable with the shield connected to the PE both at the terminal and controller end.

### 6.2 Meaning of the symbols

	Power supply (Green LED)
	Humidifier operating (yellow LED) Steady: humidity production not yet at the set point Flashing: humidity production at the set point
	Alarm (red LED) On activation of an alarm: LED flashing and buzzer active When an alarm is active, pressing ESC mutes the buzzer and the LED comes on steady, pressing ESC again resets the alarms (see Chap. 8)
<b>sec</b>	Time in seconds
<b>h</b>	Hour counter
<b>%</b>	Humidity production as a percentage of rated capacity
<b>set</b>	Parameter setup
	Maintenance request (active alarm)
	On steady: humidifier fan operating. Flashing: fan on during deactivation phase
<b>888</b>	3 digits, after 999 the display shows to indicated the 1000s (the three digits are displayed with a dot at the top between the first and second digit).

	Humidity production in progress
	Tank filling
	Water in the tank
	Water draining from the tank

Tab. 6.a

### 6.3 Keypad

button	function
<b>Esc</b>	return to the previous display
UP	from the main screen: display the humidification values, see the following paragraph from the list of parameters: scroll the parameters and set the values
DOWN	from the main screen: display the humidification values from the list of parameters: scroll the parameters and set the values
ENTER (PRG)	for 2 seconds: access the list of parameters inside the list of parameters: select and confirm (like "Enter" on a computer keyboard)

Tab. 6.b

### 6.4 Main display

The humidifier display normally shows control signal status.

For ON/OFF or proportional input signal (A0=0, A0=1, A0=3 and Th probe disconnected):

- display input signal;
- tank hour counter (h).
- maximum water vapour production control (parameter P0) (\*);
- control hysteresis (parameter P1) (\*);

For humidity probe input signal (A0=2, A0=3 and Th probe connected):

- display humidity probe reading;
- display temperature (Th only)
- tank hour counter (h).
- maximum water vapour production control (parameter P0) (\*);
- control hysteresis (parameter P1)(\*)
- Humidity Setpoint (parameter St)(\*)

To return to the main display press ESC.

Parameter C0 (see Chap. 7) can be used to change the value shown on the main display (default: display input signal).

If the humidifier is disabled (contact ON-OFF open, see Fig. 4.d), the display shows "—" alternatively to the main screen (LED signal: Standby). If the display shows "---", it means a communication error between display and humidifier: control connection cable. If the problem persists, call for service.

(\*) To modify the parameter displayed press:

- ENTER (display: **set**);
- UP or DOWN to set the value
- ENTER to confirm the new value.

Press ESC to return to the main screen. The parameters can also be accessed from the list of parameters (see Chap. 7).

## 6.5 Display software release

---

- 1) on power-up the display shows "rel. x.y" (e.g. rel. 1.2);
- 2) during operation;
  - a) on the display: from the main screen press ESC and UP together, the following are shown in sequence: humidifier size, supply, number of phases and software release;
  - b) via network on integer variable 81. Format "## = #.#"  
(e.g. 12 = release 1.2)"

## 6.6 Accessing and setting parameters

---

The configuration parameters can be used to set and control humidifier functions and status.

From the main screen press:

- ENTER for 2 seconds,
  - enter the password 77 using UP or DOWN,
  - ENTER to confirm and access the list of parameters,
  - UP or DOWN to scroll the list,
  - ENTER to select a parameter (display: 'set'),
  - UP to modify (increase) the value of the parameter. To scroll faster press DOWN together,
  - DOWN to modify (decrease) the value of the parameter. To scroll faster press UP together,
  - ENTER to save the new value and return to the list of parameters, or ESC to return to the list without saving the value,
- Press ESC to return to the main screen.

## 6.7 Parameters: Recall default values

---

The default values of the parameters can be recalled at any time from the main screen.

From the main screen press:

- ENTER for 2 seconds,
- enter the password 50 using UP or DOWN and press ENTER,
- The message dEF flashes: to recall the default values press ENTER, or ESC to exit.

If no button is pressed for 30 seconds, the display returns to the main screen without recalling the default values.

## 6.8 Reset hour counter from display

---

- Access parameter 'd3' (see Chap. 7)
- press UP and DOWN for 5 seconds

When reset is complete, 'res' is shown on the display.



## 7. CONFIGURATION PARAMETERS

To access and set the following parameters, see chapters 6 and 12.

### 7.1 Basic parameters

Parameter		UOM	range	def	note
A0	Operating mode 0 = On/Off mode from auxiliary card probe input 1 = Proportional mode from auxiliary probe input 2 = Humidity probe mode from auxiliary card probe input 3 = Auto mode: if fitted, humidity probe TH reading is used, otherwise On/Off mode from contact on main board. Parameter A2 is not used	-	0-3	3	
A1	Unit of measure 0 = Celsius ; 1 = Fahrenheit	-	0-1	0	
A2	Type of external sensor (optional card) (0 = On/Off ; 1 = 0-10V; 2 = 2-10V; 3 = 0-20 mA; 4 = 4-20 mA)	-	0-4	1	
P0	Maximum production <sup>(1)</sup>	%	10-100	100	only if terminal connected, otherwise values set by dipswitch
P1	Humidity control hysteresis	%rH	2-20	2	
St	Humidity set point <sup>(1)</sup>	%rH	20-80	50	only if terminal connected, otherwise values set by dipswitch
C0	Default display (Terminal)	-	0-5	0	

Tab. 7.a

### 7.2 Advanced parameters

Parameter		UOM	range	def	note
A3	Probe minimum	RH%	0-100	0	
A4	Probe maximum	RH%	0-100	100	
A5	Probe offset	RH%	99-100	0	
A6	Fan off delay time	min	0-240	5	
A7	Fan speed	%	40-100	100	
A8	Maximum evaporation time for reduced production alarm	min	0-200	30	
A9	Minimum evaporation time for reduced production alarm	min	0-200	1	
AA	Retry waiting time	min	1...60	10	
Ab	Percentage of A8 at which to run the level test	%	50...90	70	
b0	Operating options (see Tab. 7.c)	-	0..63	7	
b1	Time between two washing cycles	min	0-120	60	
b2	Inactivity time for washing	h	0-255	24	
b3	Washing time (fill + drain)	min	0-10	1	
b4	Start delay time	s	0-240	10	
b5	Operating hours for CL alarm	h	0-3000(*)	1500	
b6	Time to display new CL alarm after reset from keypad (without resetting hour counter)	m	0-240	60	
b7	Transducer modulating control period	s	0-10	2	
b8	Probe disconnected delay	s	0-200	10	
b9	TAM reading delay	s	0-60	2	
bA	Maximum fill time	min	0-30	15	
bb	Water refill time in production	s	0-120	10	
bC	Maximum drain time	s	0-240	60	
bd	Drain opening time to completely empty tank	s	0-240	30	
bE	Delay time after measuring low level for refilling	s	0-240	20	
P1	Humidity control hysteresis	%rH	2-20	2	
P2	Low humidity alarm threshold	%rH	0-100	20	
P3	High humidity alarm threshold	%rH	0-100	80	

Tab. 7.b

(1) To change the value from the terminal it is necessary set all related dipswitch to Off. To again use the value given by the dipswitch it is necessary set one of the dipswitch to On and power off. At the next reboot the control will use again the values set by the dipswitch.

Parameter b0

b0	Unit of measure of par. b1 M = minutes H = hours	Periodical washing EC = at the end of the production cycle IN = during the production cycle	Drain SV in standby	Alarm relay AL= active alarms SP= set point reached	Alarm relay logic NO= norm. open NC= norm. closed	Reverse osmosis Off= wash due to inactivity at next start On= wash due to inactivity when disabled	Wash due to inactivity	Auto-test
0	M	IN	Open	AL	NO	Off	Off	Off
1	M	IN	Open	AL	NO	Off	Off	On
2	M	IN	Open	AL	NO	Off	On	Off
3	M	IN	Open	AL	NO	Off	On	On
4	M	IN	Open	AL	NO	On	Off	Off
5	M	IN	Open	AL	NO	On	Off	On
6	M	IN	Open	AL	NO	On	On	Off
7	M	IN	Open	AL	NO	On	On	On
8	M	IN	Open	AL	NC	Off	Off	Off
9	M	IN	Open	AL	NC	Off	Off	On
10	M	IN	Open	AL	NC	Off	On	Off
11	M	IN	Open	AL	NC	Off	On	On
12	M	IN	Open	AL	NC	On	Off	Off
13	M	IN	Open	AL	NC	On	Off	On
14	M	IN	Open	AL	NC	On	On	Off
15	M	IN	Open	AL	NC	On	On	On
16	M	IN	Open	SP	NO	Off	Off	Off
17	M	IN	Open	SP	NO	Off	Off	On
18	M	IN	Open	SP	NO	Off	On	Off
19	M	IN	Open	SP	NO	Off	On	On
20	M	IN	Open	SP	NO	On	Off	Off
21	M	IN	Open	SP	NO	On	Off	On
22	M	IN	Open	SP	NO	On	On	Off
23	M	IN	Open	SP	NO	On	On	On
24	M	IN	Open	SP	NC	Off	Off	Off
25	M	IN	Open	SP	NC	Off	Off	On
26	M	IN	Open	SP	NC	Off	On	Off
27	M	IN	Open	SP	NC	Off	On	On
28	M	IN	Open	SP	NC	On	Off	Off
29	M	IN	Open	SP	NC	On	Off	On
30	M	IN	Open	SP	NC	On	On	Off
31	M	IN	Open	SP	NC	On	On	On
32	M	IN	Closed	AL	NO	Off	Off	Off
33	M	IN	Closed	AL	NO	Off	Off	On
34	M	IN	Closed	AL	NO	Off	On	Off
35	M	IN	Closed	AL	NO	Off	On	On
36	M	IN	Closed	AL	NO	On	Off	Off
37	M	IN	Closed	AL	NO	On	Off	On
38	M	IN	Closed	AL	NO	On	On	Off
39	M	IN	Closed	AL	NO	On	On	On
40	M	IN	Closed	AL	NC	Off	Off	Off
41	M	IN	Closed	AL	NC	Off	Off	On
42	M	IN	Closed	AL	NC	Off	On	Off
43	M	IN	Closed	AL	NC	Closed	On	On
44	M	IN	Closed	AL	NC	On	Off	Off
45	M	IN	Closed	AL	NC	On	Off	On
46	M	IN	Closed	AL	NC	On	On	Off
47	M	IN	Closed	AL	NC	On	On	On
48	M	IN	Closed	SP	NO	Off	Off	Off
49	M	IN	Closed	SP	NO	Off	Off	On
50	M	IN	Closed	SP	NO	Off	On	Off
51	M	IN	Closed	SP	NO	Off	On	On
52	M	IN	Closed	SP	NO	On	Off	Off
53	M	IN	Closed	SP	NO	On	Off	On
54	M	IN	Closed	SP	NO	On	On	Off
55	M	IN	Closed	SP	NO	On	On	On
56	M	IN	Closed	SP	NC	Off	Off	Off
57	M	IN	Closed	SP	NC	Off	Off	On
58	M	IN	Closed	SP	NC	Closed	On	Off
59	M	IN	Closed	SP	NC	Off	On	On
60	M	IN	Closed	SP	NC	On	Off	Off
61	M	IN	Closed	SP	NC	On	Off	On
62	M	IN	Closed	SP	NC	On	On	Off
63	M	IN	Closed	SP	NC	On	On	On
64	M	EC	Open	AL	NO	Off	Off	Off
65	M	EC	Open	AL	NO	Off	Off	On
66	M	EC	Open	AL	NO	Off	On	Off
67	M	EC	Open	AL	NO	Off	On	On
68	M	EC	Open	AL	NO	On	Off	Off
69	M	EC	Open	AL	NO	On	Off	On
70	M	EC	Open	AL	NO	On	On	Off
71	M	EC	Open	AL	NO	On	On	On
72	M	EC	Open	AL	NC	Off	Off	Off
73	M	EC	Open	AL	NC	Off	Off	On
74	M	EC	Open	AL	NC	Off	On	Off
75	M	EC	Open	AL	NC	Off	On	On
76	M	EC	Open	AL	NC	On	Off	Off
77	M	EC	Open	AL	NC	On	Off	On

b0	Unit of measure of par. b1 M = minutes H = hours	Periodical washing EC = at the end of the production cycle IN = during the production cycle	Drain SV in standby	Alarm relay AL= active alarms SP= set point reached	Alarm relay logic NO= norm. open NC= norm. closed	Reverse osmosis Off= wash due to inactivity at next start On= wash due to inactivity when disabled	Wash due to inactivity	Auto-test
78	M	EC	Open	AL	NC	On	On	Off
79	M	EC	Open	AL	NC	On	On	On
80	M	EC	Open	SP	NO	Off	Off	Off
81	M	EC	Open	SP	NO	Off	Off	On
82	M	EC	Open	SP	NO	Off	On	Off
83	M	EC	Open	SP	NO	Off	On	On
84	M	EC	Open	SP	NO	On	Off	Off
85	M	EC	Open	SP	NO	On	Off	On
86	M	EC	Open	SP	NO	On	On	Off
87	M	EC	Open	SP	NO	On	On	On
88	M	EC	Open	SP	NC	Off	Off	Off
89	M	EC	Open	SP	NC	Off	Off	On
90	M	EC	Open	SP	NC	Off	On	Off
91	M	EC	Open	SP	NC	Off	On	On
92	M	EC	Open	SP	NC	On	Off	Off
93	M	EC	Open	SP	NC	On	Off	On
94	M	EC	Open	SP	NC	On	On	Off
95	M	EC	Open	SP	NC	On	On	On
96	M	EC	Closed	AL	NO	Off	Off	Off
97	M	EC	Closed	AL	NO	Off	Off	On
98	M	EC	Closed	AL	NO	Off	On	Off
99	M	EC	Closed	AL	NO	Off	On	On
100	M	EC	Closed	AL	NO	On	Off	Off
101	M	EC	Closed	AL	NO	On	Off	On
102	M	EC	Closed	AL	NO	On	On	Off
103	M	EC	Closed	AL	NO	On	On	On
104	M	EC	Closed	AL	NC	Off	Off	Off
105	M	EC	Closed	AL	NC	Off	Off	On
106	M	EC	Closed	AL	NC	Off	On	Off
107	M	EC	Closed	AL	NC	Off	On	On
108	M	EC	Closed	AL	NC	On	Off	Off
109	M	EC	Closed	AL	NC	On	Off	On
110	M	EC	Closed	AL	NC	On	On	Off
111	M	EC	Closed	AL	NC	On	On	On
112	M	EC	Closed	SP	NO	Off	Off	Off
113	M	EC	Closed	SP	NO	Off	Off	On
114	M	EC	Closed	SP	NO	Off	On	Off
115	M	EC	Closed	SP	NO	Off	On	On
116	M	EC	Closed	SP	NO	On	Off	Off
117	M	EC	Closed	SP	NO	On	Off	On
118	M	EC	Closed	SP	NO	On	On	Off
119	M	EC	Closed	SP	NO	On	On	On
120	M	EC	Closed	SP	NC	Off	Off	Off
121	M	EC	Closed	SP	NC	Off	Off	On
122	M	EC	Closed	SP	NC	Off	On	Off
123	M	EC	Closed	SP	NC	Off	On	On
124	M	EC	Closed	SP	NC	On	Off	Off
125	M	EC	Closed	SP	NC	On	Off	On
126	M	EC	Closed	SP	NC	On	On	Off
127	M	EC	Closed	SP	NC	On	On	On
128	H	IN	Open	AL	NO	Off	Off	Off
129	H	IN	Open	AL	NO	Off	Off	On
130	H	IN	Open	AL	NO	Off	On	Off
131	H	IN	Open	AL	NO	Off	On	On
132	H	IN	Open	AL	NO	On	Off	Off
133	H	IN	Open	AL	NO	On	Off	On
134	H	IN	Open	AL	NO	On	On	Off
135	H	IN	Open	AL	NO	On	On	On
136	H	IN	Open	AL	NC	Off	Off	Off
137	H	IN	Open	AL	NC	Off	Off	On
138	H	IN	Open	AL	NC	Off	On	Off
139	H	IN	Open	AL	NC	Off	On	On
140	H	IN	Open	AL	NC	On	Off	Off
141	H	IN	Open	AL	NC	On	Off	On
142	H	IN	Open	AL	NC	On	On	Off
143	H	IN	Open	AL	NC	On	On	On
144	H	IN	Open	SP	NO	Off	Off	Off
145	H	IN	Open	SP	NO	Off	Off	On
146	H	IN	Open	SP	NO	Off	On	Off
147	H	IN	Open	SP	NO	Off	On	On
148	H	IN	Open	SP	NO	On	Off	Off
149	H	IN	Open	SP	NO	On	Off	On
150	H	IN	Open	SP	NO	On	On	Off
151	H	IN	Open	SP	NO	On	On	On
152	H	IN	Open	SP	NC	Off	Off	Off
153	H	IN	Open	SP	NC	Off	Off	On
154	H	IN	Open	SP	NC	Off	On	Off
155	H	IN	Open	SP	NC	Off	On	On
156	H	IN	Open	SP	NC	On	Off	Off

b0	Unit of measure of par. b1 M = minutes H = hours	Periodical washing EC = at the end of the production cycle IN = during the production cycle	Drain SV in standby	Alarm relay AL= active alarms SP= set point reached	Alarm relay logic NO= norm. open NC= norm. closed	Reverse osmosis Off= wash due to inactivity at next start On= wash due to inactivity when disabled	Wash due to inactivity	Auto-test
157	H	IN	Open	SP	NC	On	Off	On
158	H	IN	Open	SP	NC	On	On	Off
159	H	IN	Open	SP	NC	On	On	On
160	H	IN	Closed	AL	NO	Off	Off	Off
161	H	IN	Closed	AL	NO	Off	Off	On
162	H	IN	Closed	AL	NO	Off	On	Off
163	H	IN	Closed	AL	NO	Off	On	On
164	H	IN	Closed	AL	NO	On	Off	Off
165	H	IN	Closed	AL	NO	On	Off	On
166	H	IN	Closed	AL	NO	On	On	Off
167	H	IN	Closed	AL	NO	On	On	On
168	H	IN	Closed	AL	NC	Off	Off	Off
169	H	IN	Closed	AL	NC	Off	Off	On
170	H	IN	Closed	AL	NC	Off	On	Off
171	H	IN	Closed	AL	NC	Off	On	On
172	H	IN	Closed	AL	NC	On	Off	Off
173	H	IN	Closed	AL	NC	On	Off	On
174	H	IN	Closed	AL	NC	On	On	Off
175	H	IN	Closed	AL	NC	On	On	On
176	H	IN	Closed	SP	NO	Off	Off	Off
177	H	IN	Closed	SP	NO	Off	Off	On
178	H	IN	Closed	SP	NO	Off	On	Off
179	H	IN	Closed	SP	NO	Off	On	On
180	H	IN	Closed	SP	NO	On	Off	Off
181	H	IN	Closed	SP	NO	On	Off	On
182	H	IN	Closed	SP	NO	On	On	Off
183	H	IN	Closed	SP	NO	On	On	On
184	H	IN	Closed	SP	NC	Off	Off	Off
185	H	IN	Closed	SP	NC	Off	Off	On
186	H	IN	Closed	SP	NC	Off	On	Off
187	H	IN	Closed	SP	NC	Off	On	On
188	H	IN	Closed	SP	NC	On	Off	Off
189	H	IN	Closed	SP	NC	On	Off	On
190	H	IN	Closed	SP	NC	On	On	Off
191	H	IN	Closed	SP	NC	On	On	On
192	H	EC	Open	AL	NO	Off	Off	Off
193	H	EC	Open	AL	NO	Off	Off	On
194	H	EC	Open	AL	NO	Off	On	Off
195	H	EC	Open	AL	NO	Off	On	On
196	H	EC	Open	AL	NO	On	Off	Off
197	H	EC	Open	AL	NO	On	Off	On
198	H	EC	Open	AL	NO	On	On	Off
199	H	EC	Open	AL	NO	On	On	On
200	H	EC	Open	AL	NC	Off	Off	Off
201	H	EC	Open	AL	NC	Off	Off	On
202	H	EC	Open	AL	NC	Off	On	Off
203	H	EC	Open	AL	NC	Off	On	On
204	H	EC	Open	AL	NC	On	Off	Off
205	H	EC	Open	AL	NC	On	Off	On
206	H	EC	Open	AL	NC	On	On	Off
207	H	EC	Open	AL	NC	On	On	On
208	H	EC	Open	SP	NO	Off	Off	Off
209	H	EC	Open	SP	NO	Off	Off	On
210	H	EC	Open	SP	NO	Off	On	Off
211	H	EC	Open	SP	NO	Off	On	On
212	H	EC	Open	SP	NO	On	Off	Off
213	H	EC	Open	SP	NO	On	Off	On
214	H	EC	Open	SP	NO	On	On	Off
215	H	EC	Open	SP	NO	On	On	On
216	H	EC	Open	SP	NC	Off	Off	Off
217	H	EC	Open	SP	NC	Off	Off	On
218	H	EC	Open	SP	NC	Off	On	Off
219	H	EC	Open	SP	NC	Off	On	On
220	H	EC	Open	SP	NC	On	Off	Off
221	H	EC	Open	SP	NC	On	Off	On
222	H	EC	Open	SP	NC	On	On	Off
223	H	EC	Open	SP	NC	On	On	On
224	H	EC	Closed	AL	NO	Off	Off	Off
225	H	EC	Closed	AL	NO	Off	Off	On
226	H	EC	Closed	AL	NO	Off	On	Off
227	H	EC	Closed	AL	NO	Off	On	On
228	H	EC	Closed	AL	NO	On	Off	Off
229	H	EC	Closed	AL	NO	On	Off	On
230	H	EC	Closed	AL	NO	On	On	Off
231	H	EC	Closed	AL	NO	On	On	On
232	H	EC	Closed	AL	NC	Off	Off	Off
233	H	EC	Closed	AL	NC	Off	Off	On
234	H	EC	Closed	AL	NC	Off	On	Off
235	H	EC	Closed	AL	NC	Off	On	On

b0	Unit of measure of par. b1 M = minutes H = hours	Periodical washing EC = at the end of the production cycle IN = during the production cycle	Drain SV in standby	Alarm relay AL= active alarms SP= set point reached	Alarm relay logic NO= norm. open NC= norm. closed	Reverse osmosis Off= wash due to inactivity at next start On= wash due to inactivity when disabled	Wash due to inactivity	Auto-test
236	H	EC	Closed	AL	NC	On	Off	Off
237	H	EC	Closed	AL	NC	On	Off	On
238	H	EC	Closed	AL	NC	On	On	Off
239	H	EC	Closed	AL	NC	On	On	On
240	H	EC	Closed	SP	NO	Off	Off	Off
241	H	EC	Closed	SP	NO	Off	Off	On
242	H	EC	Closed	SP	NO	Off	On	Off
243	H	EC	Closed	SP	NO	Off	On	On
244	H	EC	Closed	SP	NO	On	Off	Off
245	H	EC	Closed	SP	NO	On	Off	On
246	H	EC	Closed	SP	NO	On	On	Off
247	H	EC	Closed	SP	NO	On	On	On
248	H	EC	Closed	SP	NC	Off	Off	Off
249	H	EC	Closed	SP	NC	Off	Off	On
250	H	EC	Closed	SP	NC	Off	On	Off
251	H	EC	Closed	SP	NC	Off	On	On
252	H	EC	Closed	SP	NC	On	Off	Off
253	H	EC	Closed	SP	NC	On	Off	On
254	H	EC	Closed	SP	NC	On	On	Off
255	H	EC	Closed	SP	NC	On	On	On

Tab. 7.c

### 7.3 Serial connection parameters

Parameter	UOM	range	def	note
C0 Default display (Terminal)	-	0-5	0	
C1 Baud rate 0 = 4800 bps; 1 = 9600 bps; 2 = 19200 bps; 3 = 38400 bps	-	0-3	2	
C2 tLAN address (if 0 = master)				
C3 Serial address	-	1-207	1	
C4 Timeout for master offline alarm	s	0-240	30	The alarm is only generated if online production control is active (see chap. 12.2)

Tab. 7.d





### 7.4 Read-only parameters

Parameter	UOM	range	def	note
d0 Th probe temperature reading	°C/°F	0-1000	0	
d1 Th probe humidity reading	%rH	0-1000	0	
d2 Configurable input reading (optional card)	% / %rH	0-100	0	
d3 Tank operating hour counter (resettable, see 6.10 and 12.8)	h	0-9999(*)	0	
d4 Unit hour counter (read-only)	h	0-9999(*)	0	
d5 Set point trimmer reading	%rH	0-80/100	0	

Tab. 7.e

(\*) after 999 the display shows **1000** to indicate the 1000s (the three digits are displayed with a dot at the top between the first and second digit).

## 8. ALARMS

red LED signal (*)	code and symbol on display (flashing)		meaning	cause	solution	alarm relay activation	action	reset
2 fast flashes	Et	-	Autotest failed	- Fill not connected or insufficient - drain open - faulty float	Check: • water supply and fill valve; • blockage of filter on fill solenoid valve; • check drain solenoid valve and drain connection;	yes	humidification interrupted	ESC / Digital 29
5 fast flashes	EP		No production	Malfunction of piezoelectric transducers	Carry out maintenance on tank	yes	humidification interrupted	ESC / Digital 29
3 fast flashes	EF		No water	Interruption to water supply or fill solenoid valve malfunction	Check: • water supply and fill valve; • blockage of filter on fill solenoid valve	yes (in the 10 minute waiting period)	humidification interrupted only per 10 minutes	automatic (after 10 minute wait, see Chap. 5.8)
4 fast flashes	Ed		No drain	Drain solenoid valve/circuit malfunction	Check drain valve and drain connection	yes	humidification interrupted	ESC / Digital 29
5 slow flashes	CL		Tank maintenance request signal	1500 operating hours for recommended maintenance exceeded	Carry out maintenance on tank and transducers (cap. 9)	no	signal only	Reset hour counter (See Chap 5.6 or 6.8)
6 fast flashes	PU	-	External control signal not connected correctly	Cable interrupted/disconnected/not connected correctly.	Check the reference signal (4 to 20 mA or 2 to 10V).	yes	humidification interrupted	AUTO
2 slow flashes	H^		High humidity	The signal from the probe indicates humidity above 80%rH	Check humidity probe signal/cable	yes	humidification interrupted	AUTO
3 slow flashes	H_		Low humidity	The signal from the probe indicates humidity less than 20%rH	Check humidity probe signal/cable	yes	humidification interrupted	AUTO
4 slow flashes	EE		EEPROM alarm	Problems in the EEPROM	If the problem persists, contact the CAREL service centre	yes	humidification interrupted	If this persists contact service
1 fast flash	E0		Functional test not performed	Functional test not performed by manufacturer/EEPROM problems	If the problem persists, contact the CAREL service centre	yes	humidification interrupted	If this persists contact service
7 slow flashes	OFL		Master Offline	Loss of connection from the serial master (If D37=1)	Check state of the Master / Cable	yes	humidification interrupted	AUTO

To reset the alarms, press ESC once to mute the buzzer, press ESC a second time to completely reset the alarm.

(\*) Fast flash: 0.2 seconds ON and 0.2 seconds OFF  
Slow flash: 1 second ON and 1 second OFF

## 9. MAINTENANCE AND SPARE PARTS

### 9.1 Spare parts

Table of water circuit, electrical and electronic spare part numbers

	part number	pos.	fig.
<b>Water circuit</b>			
Fill solenoid valve kit	UUKFV00000	F	9.a
Drain solenoid valve kit	UUKDV00000	E	9.a
<b>Water circuit - 2 transducers (UU01F)</b>			
Tank complete with transducers	UUKC200000	B	9.a
Cover with fan and level sensor	UUKCO00000	L	9.a
<b>Water circuit - 4 transducers (UU01G)</b>			
Tank complete with transducers	UUKC400000	B	9.a
Cover with fan and level sensor	UUKCD00000	L	9.a
<b>Electrical and electronic parts</b>			
Main electronic board	UUF02S0000	D	9.a
Main board + auxiliary card	UUF02M0000	D + H	9.a
Pair of transducers with fastening plate	UUKPZ00000		
<b>Electrical and electronic parts - 2 transducers (UU01F)</b>			
Power transformer: 230-24/36V	UUKTFD0000	A	9.a
Power transformer: 115-24/30V	UUKTF10000	A	9.a
Cable kit	UURWR00000	G	9.a
<b>Electrical and electronic parts - 4 transducers (UU01G)</b>			
Power transformer: 230-24/36V	UUKTF20000	A	9.a
Spare fuse 1A for transf. 230-24/36V	0605640AXX	-	-
Spare fuse 4A for transf. 230-24/36V	0605621AXX	-	-
Power transformer: 115-24/30V	UUKTF30000	A	9.a
Cable kit 115V	UUKWR00000	G	9.a
	230V	UUKWR10000	G 9.a
Transducer cable extension	UUKPP00000	C	9.a

Tab. 9.a

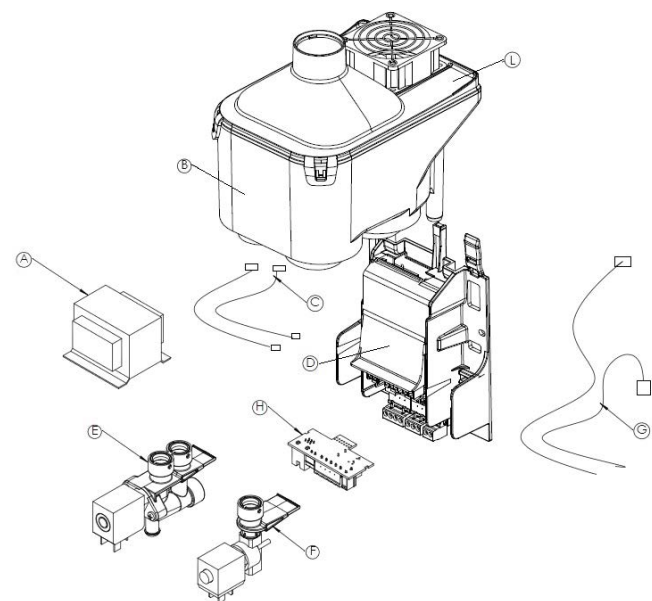

Fig. 9.b

### 9.2 Tank cleaning and maintenance

#### Replacement

**Important:** replacement must only be carried out by qualified personnel, with the humidifier disconnected from the power supply.

In normal conditions, **the tank requires maintenance after one year** (or 1500 operating hours, if cleaned periodically), **or if not used for an extended period.** Replacement is required immediately – even before the scheduled period – should problems occur.

(For example, when scale inside the tank prevents correct operation of the piezoelectric transducers)

#### Replacement procedure:

1. switch the humidifier off (switch "0"), and open the mains disconnect switch (safety procedure);
2. disconnect the transducer power cable;
3. release the tank (the two tabs at the rear) and lift it vertically to remove it;
4. clean or replace the transducers by removing the screws, see Fig. 9.b (after replacement test water-tightness by filling the tank manually)
5. reconnect the transducer power cables;
6. reposition the tank;
7. switch the humidifier on.

#### Periodical checks

- **Each year** or after no more than 1500 operating hours:
  - clean the piezoelectric transducers
  - make sure the level sensor slides freely

**Important:** in the event of water leaks, disconnect the humidifier from the power supply and repair the leak

### 9.3 Cleaning and maintenance of other components

- when cleaning plastic parts do not use detergents/solvents;
- descaling can be performed using a 20% acetic acid solution, followed by rinsing with water;
- to replace the transducers, loosen with the screwdriver the screws shown in Fig. 9.b, being careful not to pull or force. An improper maintenance can cause future water losses from the tank.

#### Maintenance checks on other components:

- fill solenoid valve. After having disconnected the cables and hoses, remove the solenoid valve, check the inlet filter and clean if necessary, using water and a soft brush.

**Important:** after having replaced or checked the water circuit components, make sure the connections are restored correctly.



Fig. 9.c

# 10. WIRING DIAGRAMS

## 10.1 Diagram

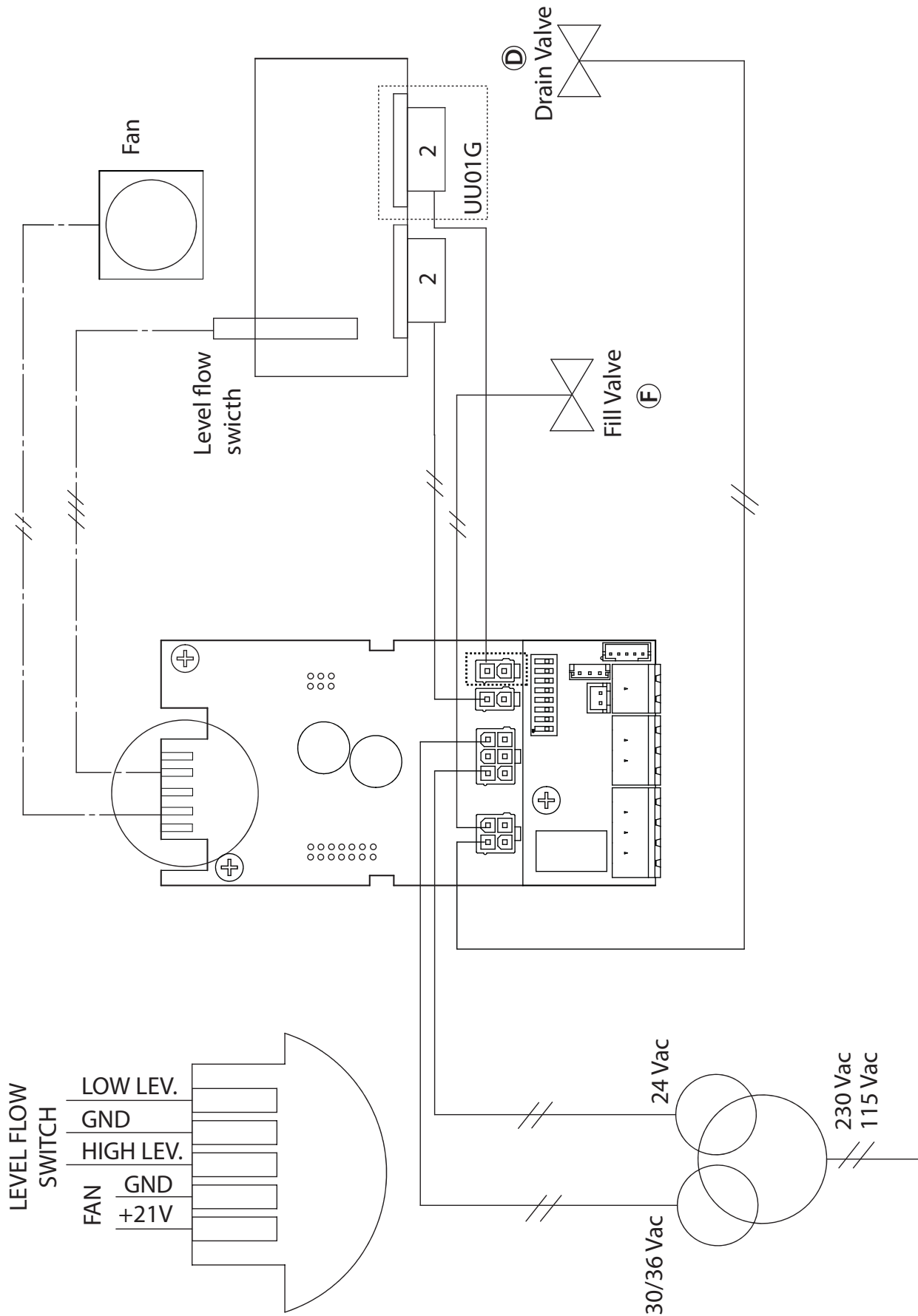

Fig. 10.a



## 11. GENERAL FEATURES AND MODELS

### 11.1 Ultrasound humidifier models for fan coils and electrical specifications

The table below summarises the electrical data (power supply voltages) of the various models, as well as their functional characteristics. Note that some models can be powered at different voltages, obviously with different current and humidity production values.

model	humidity production <sup>(2;4)</sup> (kg/h)	power <sup>(2)</sup> (W)	power supply		current <sup>(2)</sup> (A)	cable <sup>(3)</sup> (mm <sup>2</sup> )	wiring diagram (Fig.)
			code	voltage <sup>(1)</sup> (V - type)			
UU01FD	0,5	40	D	230 - 1~	0,5	1,5	10.a
UU01F1	0,45	40	1	115 - 1~	0,4	1,5	10.a
UU01GD	1	100	D	230 - 1~	1	1,5	10.a
UU01G1	0,8	70	1	115 - 1~	0.8	1.5	10.a

Tab. 11.a

(1) tolerance allowed on rated mains voltage: -15%, +10%;

(2) tolerance on rated values: +5%, -10% (EN 60335-1);

(3) recommended values, referring to PVC or rubber cable in a closed conduit, 20 m (65.6 ft) long; compliance with standards in force is always required;

(4) max instant rated water vapour production: average water vapour production may depend on external factors, such as: room temperature, water quality, water vapour distribution system



**Important:** to avoid interference, keep power cables separate from probe cables.

### 11.2 Technical specifications

Technical specifications	UU models UU01*
<b>humidity outlet</b>	
connection dia. mm	40 (ensure an outlet area of 1100 mm <sup>2</sup> , e.g. 22 x 8 mm holes)
<b>supply water</b>	
connection	G 1/8" F
temperature limits °C (°F)	1 to 40 (33.8. to 104)
pressure limits (MPa)	0.1 to 0.6 (1 to 6 bar)
specific conductivity at 20°C	0 to 50 µS/cm
total hardness	0 to 25 mg/l CaCO <sub>3</sub>
temporary hardness	0 to 15 mg/l CaCO <sub>3</sub>
total quantity of dissolved solids (cR)	depending on specific conductivity <sup>(1)</sup>
dry residue at 180°C	depending on specific conductivity <sup>(1)</sup>
iron + manganese	0 mg/l Fe+Mn
chlorides	0 to 10 ppm Cl
silicon dioxide	0 to 1 mg/l SiO <sub>2</sub>
chlorine ions	0 mg/l Cl-
calcium sulphate	mg/l CaSO <sub>4</sub>
instant flow-rate (l/min)	0.6
<b>drain water</b>	
connection dia. mm (")	10 mm
typical temperature °C (°F)	
instant flow-rate (l/min)	7
<b>environmental conditions</b>	
ambient operating temperature °C (°F)	1..55 (33.8..131)
ambient operating humidity (% rH)	10..60
storage temperature °C (°F)	-10..60 (14..140)
storage humidity (% rH)	5 to 95 (41 to 203)
index of protection	IP20
<b>electronic controller</b>	
auxiliary voltage/frequency (V- Hz)	24 V / 50-60 Hz
maximum auxiliary power (VA)	3
control signal inputs (general features)	can be selected for the following signals: 0 to 10 Vdc, 2 to 10 Vdc, 0 to 20 mA, 4 to 20 mA, input impedance: 20 kΩ with signals: 0 to 10 Vdc, 2 to 10 Vdc 100 Ω with signals: 0 to 20 mA, 4 to 20 mA
alarm relay outputs (general features)	24 V (max 3 W)
remote enabling signal input (general features)	voltage-free contact; max. resistance 100 Ω; Vmax= 5 Vdc; Imax= 5 mA
<b>power</b>	
instant water vapour production <sup>(2)</sup> kg/h (lb/h)	see Tab. 11.a
power consumption at rated voltage (W)	see Tab. 11.a

Tab. 11.b

<sup>(1)</sup> = in general  $C_R \cong 0,65 * \sigma_{R,20^\circ C}; R_{180} \cong 0,93 * \sigma_{R,20^\circ C}$

<sup>(2)</sup> = average water vapour production is affected by factors such as: room temperature, water quality, water vapour distribution system

## 12. HUMIDIFIER CONTROL VIA NETWORK

The variables shown in the list are a set of all the internal variables. **DO NOT CONFIGURE ANY VARIABLES THAT ARE NOT SHOWN IN THE TABLE, OTHERWISE HUMIDIFIER OPERATION MAY BE AFFECTED.**

The serial connection (M11) is configured by default with the following parameters:

- Address 1
- Baud rate 19200 bps
- Frame 8,N,2

### 12.1 Supervisor variable list

"A"		analogue variables* (Modbus®: REGISTERS)	R/W
CAREL - Modbus®			
1		param. d0: Th probe temperature reading	R
2		param. d1: Th probe humidity reading	R
3		param. d2: Probe reading	R
4		param. d5: Set point trimmer reading	R
"I"		integer variables (Modbus®: REGISTERS)	R/W
CAREL	Modbus®		
1	129	Level access password	R/W
2	130	Firmware release	R
15	143	Alarms, see Cap.8 ALARMS: <ul style="list-style-type: none"> <li>• bit0: E0 Alarm</li> <li>• bit1: Et Alarm</li> <li>• bit2: EF Alarm</li> <li>• bit3: Ed Alarm</li> <li>• bit4: EP Alarm</li> <li>• bit5: PU Alarm</li> <li>• bit6: H ~ Alarm</li> <li>• bit7: H_ Alarm</li> <li>• bit8: EE Alarm</li> <li>• bit9: CL Alarm</li> </ul>	R/W
20	148	Parameter A0: Operating mode	R/W
21	149	Parameter A2: Type of external sensor	R/W
22	150	Parameter A3: Probe minimum	R/W
23	151	Parameter A4: Probe maximum	R/W
24	152	Parameter A5: Probe offset	R/W
25	153	Parameter A6: Fan off delay time	R/W
26	154	Parameter A7: Fan speed	R/W
27	155	Parameter A8: Maximum evaporation time for no production alarm	R/W
28	156	Parameter A9: Minimum evaporation time for no production alarm	R/W
29	157	Parameter b0: Operating options	R/W
30	158	Parameter b1: Time between two washing cycles	R/W
31	159	Parameter b2: Inactivity time for washing on next start	R/W
32	160	Parameter b3: Washing time (fill + drain)	R/W
33	161	Parameter b4: Start delay time	R/W
34	162	Parameter b5: Operating hours for CL alarm	R/W
35	163	Parameter b6: Time to display new CL alarm in minutes	R/W
36	164	Parameter b7: Transducer On/Off control interval	R/W
37	165	Parameter b8: Probe delay disconnected	R/W
38	166	Parameter b9 TAM OFF delay	R/W
39	167	Parameter bA: Maximum fill time	R/W
40	168	Parameter bb: Refill time in evaporation	R/W
41	169	Parameter bC: Maximum drain time	R/W
42	170	Parameter bd: Drain opening time to completely empty tank	R/W
43	171	Parameter bE: Delay time after measuring low level for refilling	R/W
44	172	Parameter C0: Default display (Terminal)	R/W
45	173	Parameter C1: Parameter A0: Baud rate	R/W
46	174	Parameter C2: tLAN address (If 0 Master controller)	R/W
47	175	Parameter C3: Serial address	R/W
48	176	Parameter P0: Maximum flow-rate	R/W
49	177	Parameter P1: Humidity control hysteresis	R/W
50	178	Parameter P2: Low humidity alarm threshold	R/W
51	179	Parameter P3: High humidity alarm threshold	R/W
52	180	Parameter SP: Humidity set point	R/W
53	181	Parameter d3: Operating hour counter	R
54	182	Parameter d4: Unit hour counter (not resettable)	R/W
60	188	Serial request (If digital 37 is setted)	R/W
65	192	Parameter C4: Timeout for offline master serial	R/W

Tab. 12.a

"D"	digital variables (Modbus®: COILS)	R/W
CAREL - Modbus®		
2	Just started flag	R
3	Humidifier ready to produce	R
4	Humidity set point reached	R
5	Green LED	R
6	Red LED	R
7	Yellow LED	R
8	Remote On/Off	R
9	Low level	R
10	High level	R
11	Aux level	R
12	Autotest completed	R
14	BMS serial in tLAN mode	R
15	TAM enabled	R
16	TAM reading	R
17	Terminal connected	R
18	Production in progress	R
19	Fill	R
20	Drain	R
21	Transducer 1	R
22	Transducer 2	R
23	Fan	R
24	Alarm relay	R
25	Auxiliary relay	R
26	Manual drain	R/W
27	Disable from serial	R/W
28	Reset hour counter	R/W
29	Reset alarms	R/W
30	Washing due to inactivity activated	R
31	Functional test performed	R
33	Unit of measure	R/W
37	Serial control enable	R/W
38	Activate wash from serial	R/W

Tab. 12.b

## 12.2 Production control via network

To control production via a he connection, configure the humidifier using following parameters:

### Digital 27, Digital 37 and Integer 60 (Modbus 188)

When the D37 is at 1, the humidifier excludes the external command signals (external regulator or probes) and uses the value of Integer 60 (modbus 188) as like comand signal. The humidity production can be managed in two modes:

To manage the production level in percentual mode:

- Set D 37 = 1;
- Set parameter A0 = 1 (Carel 20, Modbus 148, Proportional Mode);
- Set integer variable 60 Carel (188 Modbus) to the desired level (0-1000 = 0-100.0%).

To manage the production with a humidity probe managed by the master:

- Set D 37 = 1;
- Set parameter A0 = 2 (Carel 20, Modbus 148, Humidity probe Mode);
- Set integer variable 60 Carel (188 Modbus) to the desired level (0-1000 = 0-100.0 rH%);
- Set integer variable 52 Carel (180 Modbus) to the desired humidity setpoin.

When the D37 is at 1, if the communication is lost for the seconds settled by parameter C4, is generated the "Master Offline" alarm (see alarms table) and the production stops.

Production is activated/deactivated via digital parameter D27 (see parameter table).

If D27 = 1 the humidifier is disabled and production stops  
if D27 = 0 the humidifier is enabled and production is activated.  
D27 is independent from the state of D37.

## 12.3 Washing cycle activation via network

A washing cycle can be performed at any time by managing digital variable 38.

Setting the variable to 1 will immediately activate a washing cycle, even if the unit is in standby, and even if both automatic washing and washing due to inactivity are disabled by their corresponding parameters.

The variable will keep the value 1 throughout the duration of the washing cycle, and will automatically be reset at the end of the cycle.

## 13. OPERATING PRINCIPLES

### 13.1 Ultrasound atomisation

Ultrasound humidifiers atomise water through propagation of a wave generated by a piezoelectric element to the surface of the water. Droplets of water thus form on the surface, with the smaller ones being carried air by the forced air flow. The quantity of atomised water depends on water level, water temperature and distribution in the air.

Water level is kept constant using fill and drain valves, and a level sensor. Demineralised water is recommended: if using mains water, the scale that accumulates over time will foul the piezoelectric transducer, affecting atomisation. To avoid excessive scaling, humidifier periodically drains and automatically refills the water (see par. 12.5)

### 13.2 Control principles

The humidifier can be controlled using the following signals:

- remote ON/OFF;
- TAM (set by dipswitch);
- Humidity probe (set by dipswitch);
- Serial.

#### ON/OFF control

The action is all or nothing, activated by an external contact that consequently determines the control set point and differential. The external contact may be a humidistat, whose status determines the operation of the humidifier:

- contact closed: the humidifier produces water vapour if the remote ON/OFF contact is also closed;
- contact open: water vapour production ends.

#### Proportional control (only with optional card)

- Water vapour production is proportional to the value of a signal "Y" from an external device. The type of signal can be selected between the following standards: 0 to 10Vdc, 2 to 10Vdc, 0 to 20 mA, 4 to 20 mA
- Maximum humidifier production, corresponding to the maximum value of the external signal, can be set from 10% to 100% of the rated value of the humidifier (parameter P0).

Minimum production has an activation hysteresis, equal to the value of P1 (default 5% of the proportional band of external signal "Y").

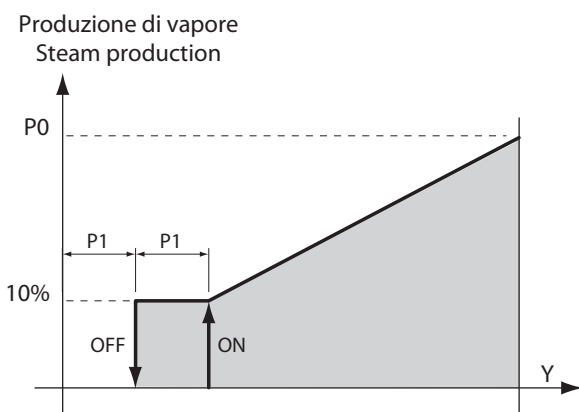

Fig. 13.a

#### Automatic control with humidity probe

Humidity production is controlled based on the reading of the relative humidity probe (TH or connection via optional card).

The humidifier will produce until reaching the set point (St, default 50 %rH), with a settable activation hysteresis (P1 default 5%) (see the figure) to maintain the set point.

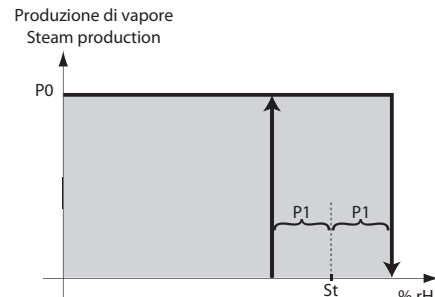

Fig. 12.a

### 13.3 Flow-rate modulation

Atomised water flow-rate can be varied from 5% to 100% (parameters Pm and P0) by alternating on-off cycles of the transducers over a set period (parameter b7, default 1 second).

Flow-rate is set based on parameter P0 (default 100%) and the request from the external signal (with optional card and proportional control).

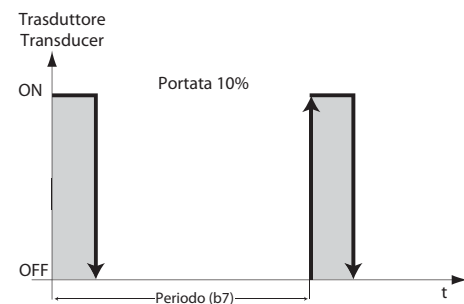

Fig. 13.b

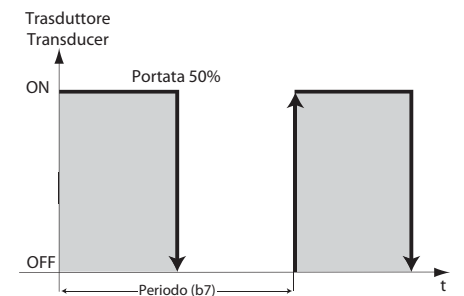

Fig. 13.c

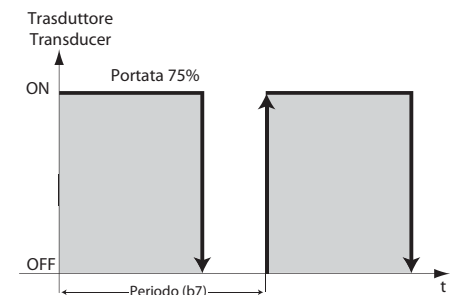

Fig. 13.d

If the flow-rate is 100%, the transducers are always on.

### 13.4 Series flow-rate modulation (4-transducer ver. only, dipswitch 8 On)

Atomised water flow-rate can be modulated as a percentage of rated production, from 10% to 100%. Each pair of transducers generates 50% of total production. If humidity demand from the external signal (when using the optional card and proportional control) and parameter P0 are both 100%, all four transducers will be activated. For lower demand, production will be split between the two pairs of transducers as follows:

51% - 99%: one pair of transducers is always activated to generate 50% of required production, while the other pair modulates - as described in the previous paragraph - to generate the remaining percentage of production.

(e.g. 75% demand: one pair of transducers is always activated, the other modulates at 50%, as shown in Fig. 13.d)

10% - 50%: one pair of transducers is always off, the other modulates - as described in the previous paragraph - to generate the required percentage of production.

(e.g. 25% demand: one pair of transducers is always off, the other modulates at 50%, as shown in Fig. 13.d)

Distribution of production between the two pairs of transducers is rotated every hour of operation, to avoid uneven ageing of the transducers.

### 13.5 Automatic insufficient supply water management

The humidifier detects if the water supply is interrupted (or insufficient) by monitoring the status of the level sensor after opening the fill solenoid valve. If the sensor is not activated within the time set for parameter bA (default 15 minutes), humidification is interrupted, the drain is activated and the appliance waits a set number of minutes (parameter AA, default 10), during which the display shows "Rty" (Retry), before attempting to fill with water again.. If this attempt succeeds, production will resume, otherwise the appliance waits a further AA minutes. The process is repeated until the water supply returns, as measured by the sensor. For the first two attempts, no alarm is generated, while if on the third attempt the procedure is not successful, alarm EF is generated, which is reset automatically when the humidifier verifies that the water supply is available again.

### 13.6 Automatic control of atomised water production

The humidifier monitors the water level inside the tank during production of atomised water. If the level does not fall, it means one of the following faults may have occurred:

- Malfunction of the piezoelectric transducers
- Leaky fill solenoid valve
- Fan malfunction

If after the set time for variable A8 (in minutes, default 30) the water level does not fall below the low level threshold, atomised water production stops and the appliance waits a set number of minutes (parameter AA, default 10), during which the display shows "Rty" (Retry), before attempting to resume production. If the situation is repeated, alarm EP is activated, which shuts down the unit.

If after a percentage of A8, set by parameter Ab (default 70%) the water is above the high level threshold, atomised water production stops, warning EL is generated and the appliance waits AA minutes (default 10), during which the display shows "Rty" (Retry), before attempting to resume production. The warning signal EL is reset at the end of a production cycle that is completed correctly.

### 13.7 Automatic control of leaking drain solenoid valve and fill solenoid valve flow-rate

Parameter A9 sets a minimum production time (default 1 minute); if the production cycle lasts less than this time, it may mean that the drain solenoid valve is leaking or that the fill solenoid valve flow-rate is too low. In this case, the controller carries out the following operations:

1. At the end of the first cycle that ends after a time less than A9, the water refill time is increased (50% higher than parameter bb) and the reduced power supply voltage to the drain solenoid valve is deactivated with the objective of increasing tightness.
2. At the end of the second cycle that ends after a time less than A9, the water refill time is increased further (100% higher than parameter bb) and a chattering\* cycle is activated on the drain solenoid valve, performed during the first automatic wash cycle.
3. At the end of the third cycle that ends after a time less than A9, the water refill time is increased further (150% higher than parameter bb) and a washing cycle is performed, during which chattering\* is applied, as enabled in the previous step. Warning Ed is also generated.
4. After the final step, a new production cycle will be activated. If the problem persists, the controller will restart the procedure from the first step, until completing a cycle in the expected time. In this case, any warnings will be reset.

\*Chattering: a sequence in which the drain solenoid valve is opened/closed in rapid succession, with the aim of removing any residues (scale, dust, etc.) that prevent it from closing correctly.





# CAREL

**CAREL INDUSTRIES HQs**

Via dell'Industria, 11 - 35020 Brugine - Padova (Italy)  
Tel. (+39) 049.9716611 - Fax (+39) 049.9716600

Agenzia / Agency: