

humiSonic

Adiabatic ultrasonic humidifiers

Ultrasonic humidification

humiSonic makes the advantages of adiabatic humidification available to small-medium applications, with energy savings of up to 90%. Available in three versions: compact, direct and ventilation.

1.0 μ • 10% • 10k

droplet size is just 1 micron: instant absorption.

power consumption compared to steam humidifiers: a saving of 90%.

guaranteed operating hours, for unprecedented reliability.

Ultrasound technology

Ultrasonic humidifiers feature a small water storage tank and piezoelectric transducers installed at the bottom of the tank. The surface of the transducer vibrates at very high speed (1.65 million times a second), a speed that does not allow the water to move due to its inertial mass. Principally due to an effect known as "cavitation", the water is atomised into fine droplets and is instantly absorbed by the air flow.

Adiabatic humidifiers

Adiabatic humidification ensures spontaneous evaporation of microscopic droplets of water in the surrounding air. The change in state absorbs energy from the air, which is thus cooled. humiSonic consumes less than 80 W of electricity for each kg of evaporated water, against the 750 W for steam humidifiers: a saving of almost 90%!

Reliability

The piezoelectric transducers used in the humiSonic range are guaranteed for 10,000 hours of continuous operation, if used with demineralised water. This characteristic means extremely low maintenance, making humiSonic a reliable solution that is suitable for mission critical applications.

Water Treatment System

CAREL has developed reverse osmosis water treatment systems designed especially for use with its humidifiers. Specifically, WTS compact, available in sizes from 12 to 60 l/h, is the ideal solution for maximising all aspects of humiSonic performance.



Why use demineralised water?

- maximum hygiene guaranteed, further assured by UV disinfection
- compact solution, easy to install
- no dust build-up in the environment
- minimal maintenance

humiSonic compact

The complete solution for humidity control in small spaces, with maximum energy savings.



humiSonic compact is the ideal solution for combining routine temperature control with precise room humidity control.

The compact design means the unit can be easily installed on the latest generation appliances, while at the same time allowing retrofits in existing systems.

Maximum hygiene

Hygiene is one of the main strengths of humiSonic compact, ensured by carrying out periodical washing cycles in which the tank is drained completely at the end of the cycle, using a drain valve. Moreover, the addition of 3% silver ions to the plastic prevents bacteria proliferation.

Energy saving

Ultrasonic humidification requires very low power consumption. humiSonic compact is therefore an "energy saving" solution that

meets current demands for low energy consumption.

A complete solution

humiSonic compact features a built-in control board and therefore does not require an external control panel. The humidifier is powered via a transformer (supplied, complete with cable kit), while the control signal can come from a voltage-free contact (ON/OFF), the special micro-probe (available as an accessory), or via a serial network with Modbus or CAREL communication protocol.

humiSonic compact is available in 0.5 and 1 kg/h sizes.

Applications

Discrete, reliable and easy to install: the applications of humiSonic compact range from comfort to fresh food storage

Fan coils

humiSonic compact, installed on a fan coil, is the ideal solution for combining routine temperature control (guaranteed by the fan coil) with precise room humidity control, ensuring comfortable conditions inside domestic and commercial environments.

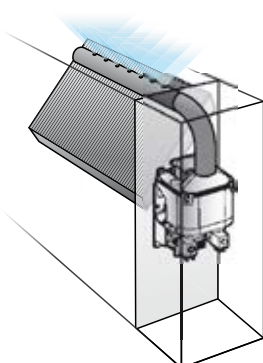

Display cabinets

The installation of humiSonic compact on display cabinets is the ideal solution for food storage, in particular confectionery, chocolates, fruit, vegetables and fresh food in general.

Hygiene is guaranteed by complete air recirculation and the frequent washing cycles run by automatically humiSonic.

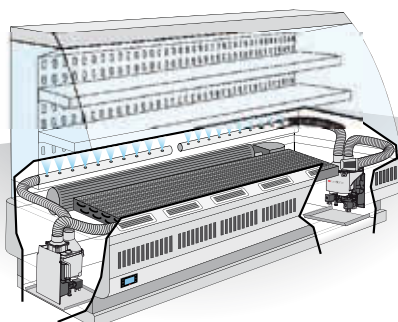

Dough retarders

Dough rising and proofing are fundamental processes in maintaining and guaranteeing food quality. For these applications, humiSonic compact is fitted with an air filter with 50µ mesh, washable directly in water, which prevents contact between the water and the dust in the environment.

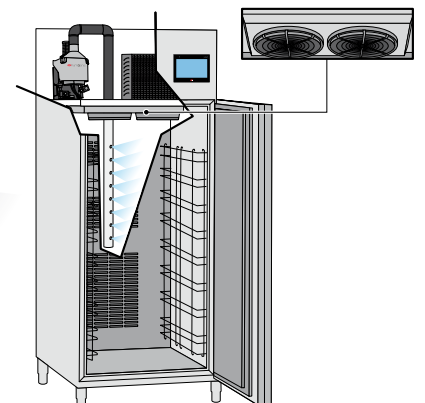

humiSonic direct

Built-in probe and no need for an external control panel: a complete solution that can be installed directly in the humidified environment.

- All-in-one solution thanks to the integrated probe and controller
- Easy to install: plug and play!
- Ideal for retrofit applications

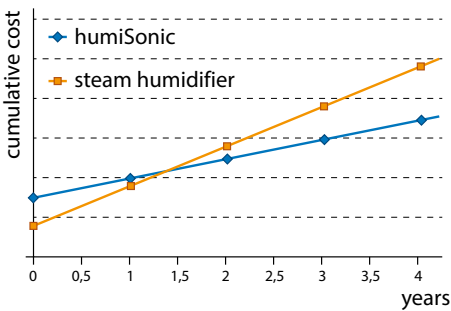

Comparison of total cost between humiSonic and an isothermal humidifier. The higher upfront investment in humiSonic is generally paid back in less than two years.

Example with electric heater humidifier, 8 kg/h demand, electricity cost 0.15 €/kW, 2500 operating hours annually.

humiSonic direct, installed directly in the room, can control relative humidity with minimum power consumption.

All-in-one solution

In room applications, it is crucial for the humidifier to have compact dimensions. Indeed, often the solution needs to adapt to an existing layout, while allowing flexibility for future changes in position. humiSonic direct is a stand-alone compact solution that comprises both the control panel/power supply and the probe for reading air humidity.

Integration

Modbus compatibility, available as standard, means humiSonic direct can communicate with the BMS, ensuring complete integration with the rest of the installation.

Precise and hygienic

humiSonic modulates atomised water production linearly, precisely reflecting the control signal: when combined with a suitable humidity probe, precision of $\pm 1\%$ is achievable.

Hygiene is also guaranteed by:

- all the components in contact with the water are made from stainless steel
- the main body prevents water stagnation at the end of the humidification cycle
- periodical washing cycles when the system is not running.

More functional

Using an optional card, humiSonic direct can be connected to a display for optimising unit configuration quickly and intuitively, as well as to receive a signal from an external controller or active probe.

humiSonic direct is available in sizes from 2 to 8 kg/h.



Energy saving

humiSonic consumes 90% less electricity than any steam humidifier.



Mission critical DNA

10,000 hours of continuous operation guaranteed, when used with demineralised water. Low maintenance, simply and quickly.



Flexibility

With the master/slave function, up to four units can work in parallel to extend total system capacity.

Applications

From data centers to comfort applications: easy installation, precision and reliability make humiSonic direct an extremely versatile product.

Data centers

The heat produced by the computers can readily cause relative humidity to drop below 35%, the limit value for avoiding the risk of electrostatic discharges. In small data centers, installing humiSonic direct in the hot aisle means no steam humidifiers are needed in the CCU. In addition, the evaporative cooling effect lightens the workload for the cooling system, bringing further energy savings.

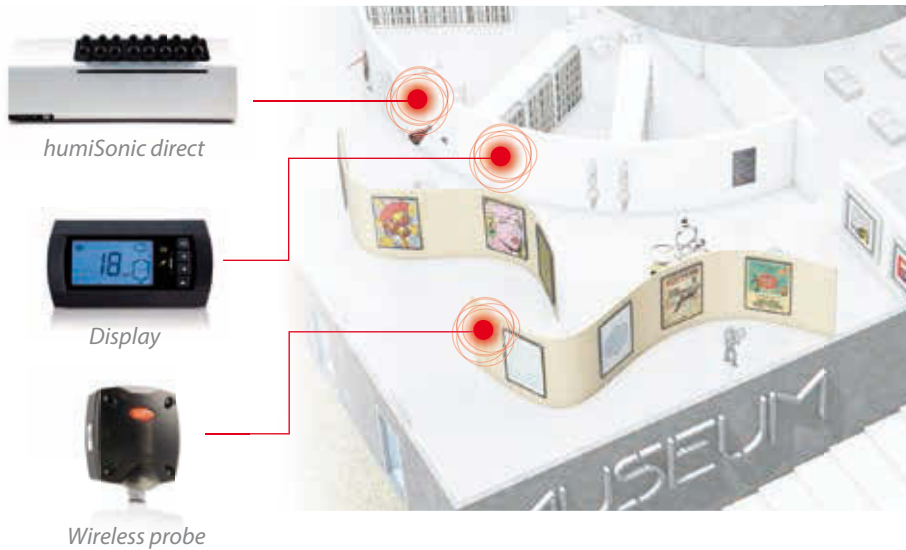
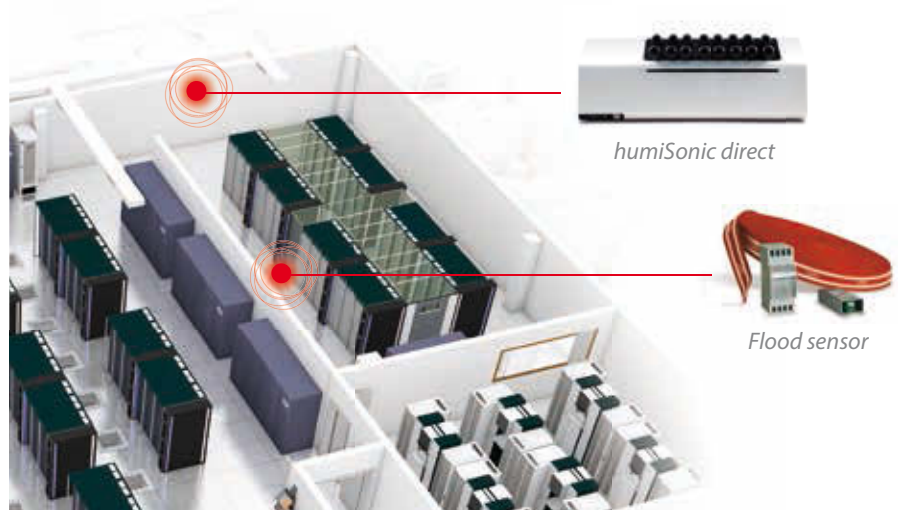

Museums and libraries

Wood and paper are hygroscopic materials, and therefore sensitive to the relative humidity level in the air: swings in humidity lead to cracks and breakages, even on paintings. For correct preservation of artworks and structures, the level of humidity needs to be kept constant. humiSonic direct in the 8 kg/h size can humidify a 300 m² room, with capacity being extendable using the master/slave function.

Offices

In winter, the air in heated rooms tends to become very dry, with humidity dropping to as low as 20%. In offices, shops and commercial spaces in general, keeping relative humidity between 40 and 60% is very important: not only to ensure comfort for customers and staff, but also to limit the proliferation and spread of viruses and bacteria.

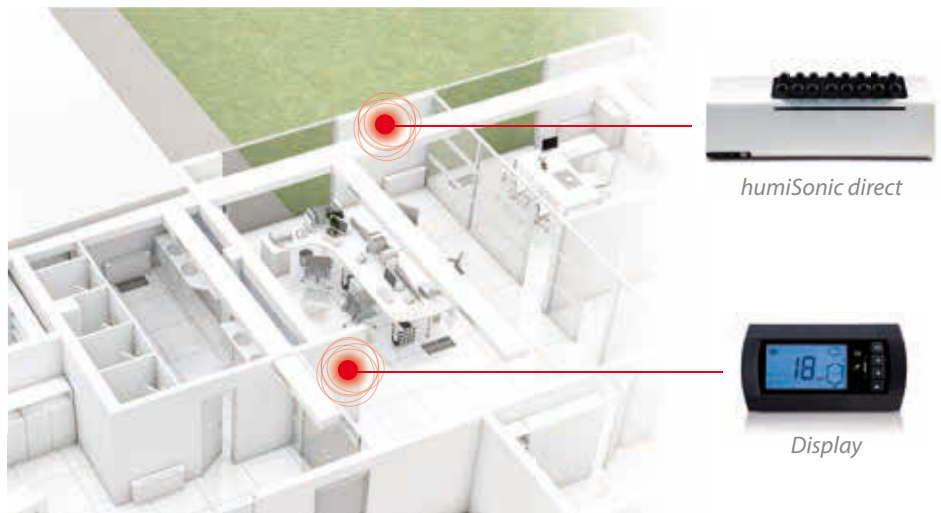

humiSonic ventilation

An alternative to steam is finally available for applications in small ducted systems. Energy saving, reliability and precision are the strengths of this solution.



- Maximum hygiene even for the most critical applications
- Easy installation and maintenance
- Very high absorption efficiency

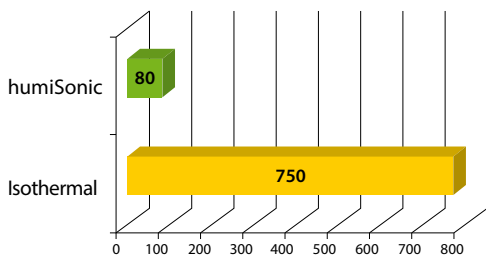

Comparison in power consumption between humiSonic and steam humidifiers (watts per kg/h of evaporated water).

Installed directly in the air flow, humiSonic ventilation makes adiabatic humidification available also in smaller ducts, offering a high energy efficiency alternative to steam humidification. Power consumption per kg of evaporated water is in fact less than 80 W, around 90% lower.

Hygiene

humiSonic ventilation embodies all the attention that CAREL has always paid to the hygiene of its humidification solutions. All components in contact with the water are made from stainless steel, and no water is left to stagnate in the main body at the end of the humidification cycle. In addition, the electronic controller manages periodical washing cycles when the system is not running.

Accurate and precise

Extremely accurate modulation, when combined with a suitable probe, means humiSonic can reach exceptional precision ($\pm 1\%$ around the relative humidity set point). This characteristic, together with the high level of hygiene, make it an ideal solution even for more critical and delicate applications, such as cleanrooms.

A complete solution

humiSonic for air handling units comprises two elements that make it a powerful and complete solution: the main body (containing the piezoelectric transducers) and the electrical power supply and control panel, fitted with display.

humiSonic ventilation is available in sizes up to 18 kg/h. Master/slave mode can be used to increase system capacity four-fold.



Energy saving

humiSonic consumes 90% less electricity than any steam humidifier.



Mission critical DNA

10,000 hours of continuous operation guaranteed, when used with demineralised water. Low maintenance, simply and quickly.



Precision

humiSonic can achieve precision of better than $\pm 1\%$ RH around the set point, when combined with a suitable probe.

Applications

Precision, maximum hygiene and reliability: humiSonic ventilation is also suitable for the most critical applications.

Industry and process

In industrial processes, it is fundamental to control the humidity and temperature conditions so that hygroscopic materials, such as paper and wood, can be processed without problems and that finished products can be correctly stored. In addition, the evaporative cooling effect can reduce or completely absorb the heat generated by the equipment.

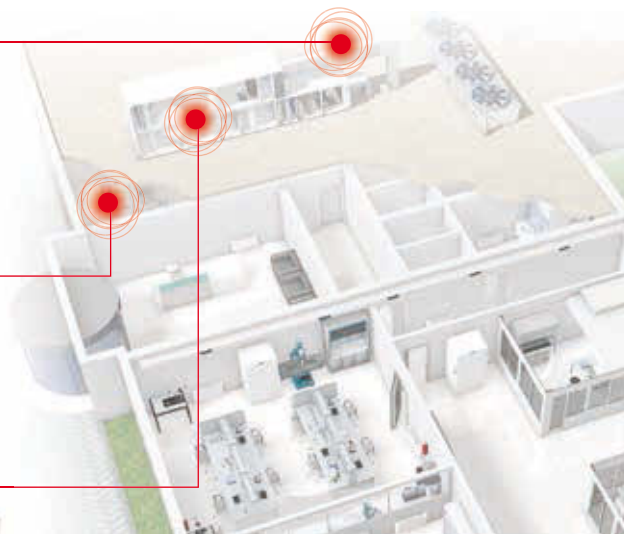
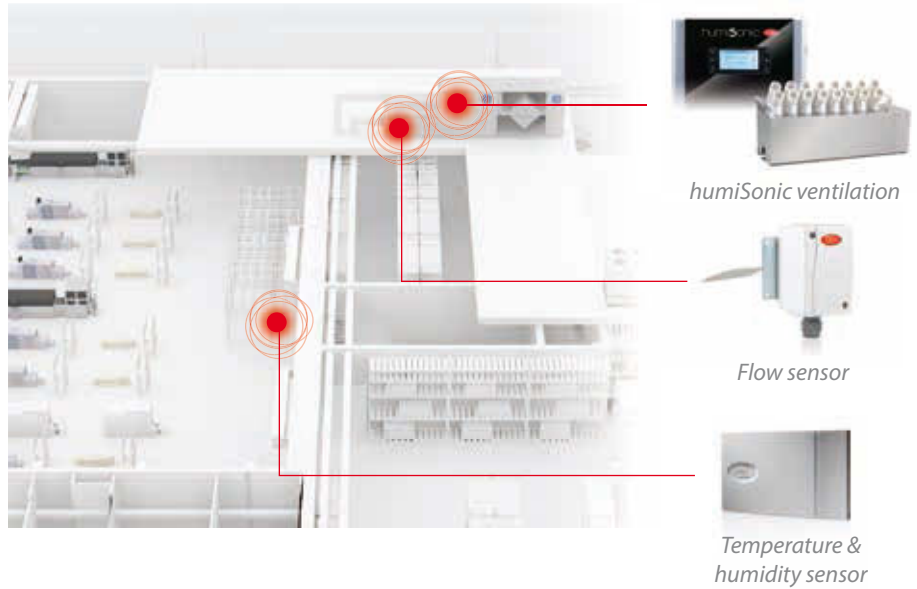

Cleanrooms

There are several reasons why precise humidity control is required; indeed, for some applications the specified tolerance is just 1%, due to the affect that relative humidity has from a physical/chemical point of view on material processing and storage. Tight humidity control therefore means greater control over processes.

Offices

In winter, the air in heated rooms tends to become very dry, with humidity dropping to as low as 20%. In offices, shops and commercial spaces in general, keeping relative humidity between 40 and 60% is very important: not only to ensure comfort for customers and staff, but also to limit the proliferation and spread of viruses and bacteria. The right humidity also helps prevent specific illnesses related to dry air, such as *semicircular lipotrophy*.

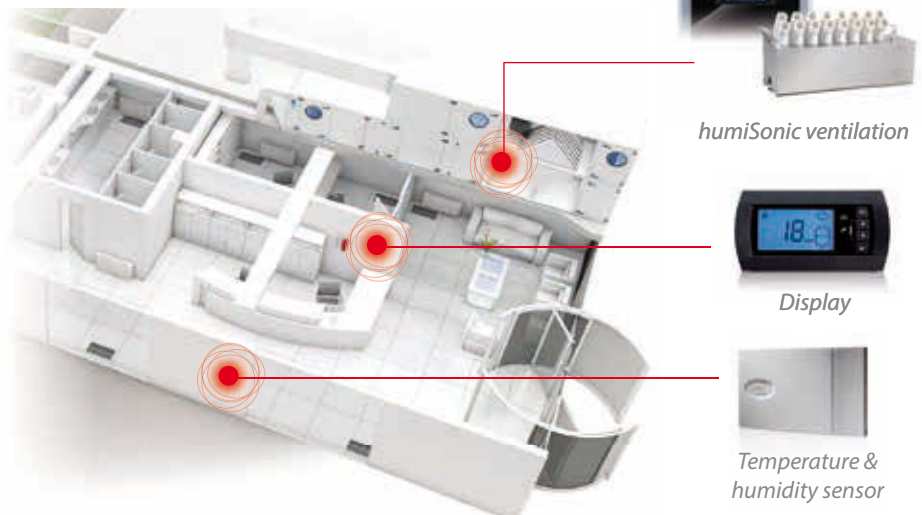

humiSonic compact datasheet

Features	UU01F*	UU01G*
Atomised water production	0.5 kg/h	1.0 kg/h
Feedwater inlet	G 1/8" F	
Feedwater pressure	0.1 to 6 bars	
Feedwater	Demineralised water	
Power supply	230 V, 50 Hz or 115 V, 60 Hz	
Installed power	230 V, 40 W; 115 V, 40 W	230 V, 100 W; 115 V, 70 W
Connections		
Enable ON/OFF	standard	standard
RS485 serial (CAREL or Modbus protocol)	standard	standard
Humidity probe HYHU000000	optional	optional
External control signals (0 to 10 V, 4 to 20 mA)	optional	optional

humiSonic direct datasheet

Features	UU02R*	UU04R*	UU06R*	UU08R*
Atomised water production	2 kg/h	4 kg/h	6 kg/h	8 kg/h
Feedwater inlet	G 1/8" F			
Feedwater pressure	0.1 to 6 bars			
Feedwater	demineralised water			
Power supply	230 V, 50 Hz or 110 V, 60 Hz			
Installed power	180 W	330 W	480 W	690 W
Connections				
Enable ON/OFF	standard	standard	standard	standard
RS485 serial (CAREL or Modbus protocol)	standard	standard	standard	standard
Humidity probe HYHU000000	optional	optional	optional	optional
External control signals (0 to 10 V, 4 to 20 mA)	only with UUKAX auxiliary card (optional)			

humiSonic ventilation datasheet

Features	UU02D*	UU05D*	UU07D*	UU09D*	UU14D*	UU18D*
Atomised water production	2.4 kg/h	4.8 kg/h	7.2 kg/h	9.6 kg/h	14.4 kg/h	18 kg/h
Feedwater inlet	G 1/8" F					
Feedwater pressure	0.1 to 6 bars					
Feedwater	demineralised water					
Power supply	230 V, 50 Hz or 110 V, 60 Hz					
Installed power	210 W	350 W	500 W	650 W	950 W	1150 W
Connections						
Enable ON/OFF	standard	standard	standard	standard	standard	standard
RS485 serial (CAREL or Modbus protocol)	standard	standard	standard	standard	standard	standard
External control signals	0 to 1 V, 0 to 5 V					