

humiFog multizone

distribution systems

CAREL



ENG User manual

**LEGGI E CONSERVA
QUESTE ISTRUZIONI**

**READ AND SAVE
THESE INSTRUCTIONS**

  **NO POWER
& SIGNAL
CABLES
TOGETHER**

READ CAREFULLY IN THE TEXT!

WARNINGS



CAREL INDUSTRIES Hq humidifiers are advanced products, whose operation is specified in the technical documentation supplied with the product or can be downloaded, even prior to purchase, from the website . Each

CAREL INDUSTRIES Hq product, in relation to its advanced level of technology, requires setup/configuration/programming/commissioning to be able to operate in the best possible way for the specific application. The failure to complete such operations, which are required/indicated in the user manual, may cause the final product to malfunction; CAREL INDUSTRIES Hq accepts no liability in such cases.

The customer (manufacturer, developer or installer of the final equipment) accepts all liability and risk relating to the configuration of the product in order to reach the expected results in relation to the specific final installation and/or equipment. CAREL INDUSTRIES Hq may, based on specific agreements, act as a consultant for the installation/commissioning/use of the unit, however in no case does it accept liability for the correct operation of the humidifier and the final installation if the warnings or suggestions provided in this manual or in other product technical documents are not heeded. In addition to observing the above warnings and suggestions, the following warnings must be heeded for the correct use of the product:

- **DANGER OF ELECTRIC SHOCK**
The humidifier contains live electrical components. Disconnect the mains power supply before accessing inside parts or during maintenance and installation;
- **DANGER OF WATER LEAKS**
The humidifier automatically and constantly fills/drains certain quantities of water. Malfunctions in the connections or in the humidifier may cause leaks;
- **For isothermal humidifiers: DANGER OF BURNS**
The humidifier contains high temperature components (100°C/212°F);
- **For gas-fired isothermal humidifiers: DANGER OF GAS LEAKS**
The humidifier is connected to the gas mains. Malfunctions in the connections or inside the humidifier may cause gas leaks.
- The installation of the product must include an earth connection, using the special yellow-green terminal available in the humidifier.
- The environmental and power supply conditions must conform to the values specified on the product rating labels.
- The product is designed exclusively to humidify rooms either directly or through distribution systems (ducts). In addition, for adiabatic-water spray-pressure humidifiers, humidification also occurs through the atomisation rack.
- Only qualified personnel who are aware of the necessary precautions and able to perform the required operations correctly may install, operate or carry out technical service on the product.
- Only water with the characteristics indicated in this manual must be used for steam or water vapour production.
- Warning, demineralised drinking water must be used for adiabatic-water spray-pressure humidifiers (as specified in the manual). In addition, the particles of water not absorbed by the air must be removed into the droplet collection tank (in the humidification section) and by the droplet separator (at the end of the humidification section).
- All operations on the product must be carried out according to the instructions provided in this manual and on the labels applied to the product. Any uses or modifications that are not authorised by the manufacturer are considered improper. CAREL INDUSTRIES Hq declines all liability for any such unauthorised use.
- Do not attempt to open the humidifier in ways other than those specified in the manual.
- Observe the standards in force in the place where the humidifier is installed.
- Keep the humidifier out of the reach of children and animals.
- Do not install and use the product near objects that may be damaged when in contact with water (or condensate). CAREL INDUSTRIES Hq declines all liability for direct or indirect damage following water leaks from the humidifier.
- Do not use corrosive chemicals, solvents or aggressive detergents to clean the inside and outside parts of the humidifier, unless specifically indicated in the user manual.
- Do not drop, hit or shake the humidifier, as the inside parts and the linings may be irreparably damaged.
- For adiabatic-water spray-pressure humidifiers: the atomised water must be distributed using a special atomising 'rack' or through distribution systems specified by CAREL INDUSTRIES Hq
- For isothermal appliances: these are designed to produce steam at atmospheric pressure, and not pressurised steam. CAREL INDUSTRIES Hq does not recommend and waives all liability for the use of distribution devices other than those specified.

CAREL INDUSTRIES Hq adopts a policy of continual development. Consequently, CAREL reserves the right to make changes and improvements to any product described in this document without prior warning. The technical specifications shown in the manual may be changed without prior warning.

The liability of CAREL INDUSTRIES Hq in relation to its products is specified in the CAREL INDUSTRIES Hq general contract conditions, available on the website and/or by specific agreements with customers; specifically, to the extent where allowed by applicable legislation, in no case will CAREL INDUSTRIES Hq, its employees or subsidiaries be liable for any lost earnings or sales, losses of data and information, costs of replacement goods or services, damage to things or people, downtime or any direct, indirect, incidental, actual, punitive, exemplary, special or consequential damage of any kind whatsoever, whether contractual, extra-contractual or due to negligence, or any other liabilities deriving from the installation, use or impossibility to use the product, even if CAREL INDUSTRIES Hq or its subsidiaries are warned of the possibility of such damage.

DISPOSAL



The humidifier is made up of metal parts and plastic parts. In reference to European Union directive 2002/96/EC issued on 27 January 2003 and the related national legislation, please note that:

1. WEEE cannot be disposed of as municipal waste and such waste must be collected and disposed of separately;
2. the public or private waste collection systems defined by local legislation must be used. In addition, the equipment can be returned to the distributor at the end of its working life when buying new equipment;
3. the equipment may contain hazardous substances: the improper use or incorrect disposal of such may have negative effects on human health and on the environment;
4. the symbol (crossed-out wheeled bin) shown on the product or on the packaging and on the instruction sheet indicates that the equipment has been introduced onto the market after 13 August 2005 and that it must be disposed of separately;
5. in the event of illegal disposal of electrical and electronic waste, the penalties are specified by local waste disposal legislation.

Warranty on the materials: 2 years (from the date of production, excluding consumables).

Approval: the quality and safety of CAREL INDUSTRIES Hq products are guaranteed by the ISO 9001 certified design and production system, as well as by the following marks.

WARNING: separate as much as possible the probe and digital input signal cables from the cables carrying inductive loads and power cables to avoid possible electromagnetic disturbance.
Never run power cables (including the electrical panel wiring) and signal cables in the same conduits.

NO POWER
& SIGNAL
CABLES
TOGETHER

READ CAREFULLY IN THE TEXT!

Content

1. COMPONENTS IN THE DISTRIBUTION SYSTEM	7
1.1 Components in the rack for installation in the duct	7
1.2 Rated specifications of the rack.....	7
1.3 Specifications of the droplet separators.....	7
1.4 Components in the room distribution system.....	8
1.5 Rated specifications of the room distribution system.....	8
2. INSTALLATION: OPERATIONS, MATERIALS AND TOOLS, DATA REQUIRED FOR INSTALLATION IN THE DUCT OR AHU	10
2.1 Planning the operations.....	10
2.2 Materials and tools	10
2.3 Data required: configuration of the rack	10
3. ASSEMBLING THE RACK	12
3.1 Atomisation circuits.....	12
3.2 Choosing the positions of the solenoid valves, direct connections, horizontal manifolds, nozzles and plugs.....	12
3.3 Assembling the main structure	13
3.4 NC/NO solenoid valve and hose assembly	14
3.5 Assembling the manifolds	16
3.6 Assembling the manifolds in the rack.....	16
3.7 Rack assembly: checklist.....	17
4. INSTALLING THE RACK IN THE DUCT	18
4.1 Connecting the cabinet to the rack	18
4.2 Junction box	18
4.3 Installing the rack in the duct/AHU.....	19
4.4 Checklist for rack installation in the duct.....	19
5. PREVENTIVE MAINTENANCE OF THE DISTRIBUTION SYSTEM	20
5.1 Maintenance menu	20
5.2 Preventive maintenance of the accessories	20
6. OPERATIONS, MATERIALS, TOOLS AND DATA REQUIRED FOR INSTALLING THE ROOM DISTRIBUTION SYSTEM	21
6.1 Materials and tools for installation in the room.....	21
6.2 Assembling the distribution system in the room.....	21

1. COMPONENTS IN THE DISTRIBUTION SYSTEM

1.1 Components in the rack for installation in the duct

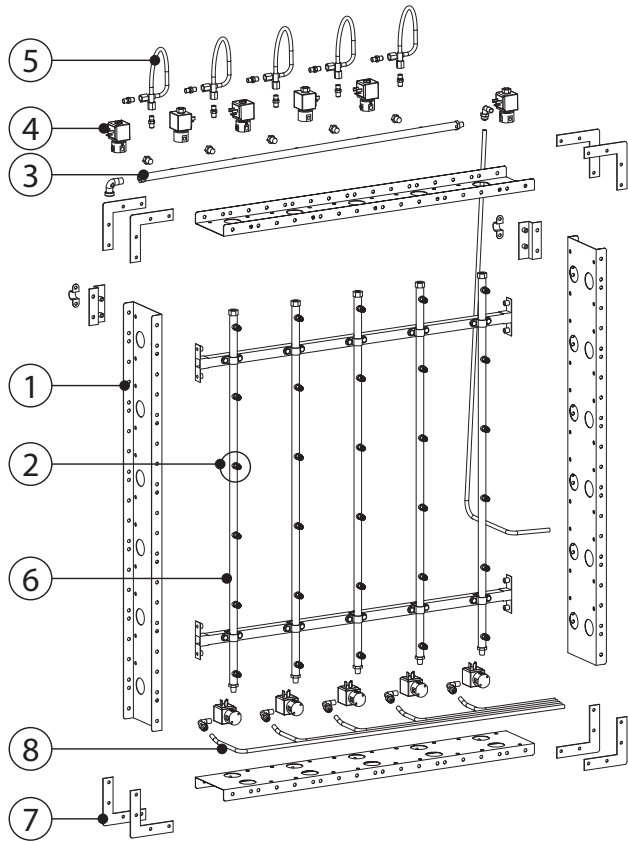

Fig. 1.a

Key:

1	stainless steel structure
2	position of nozzles/plugs
3	horizontal manifold
4	solenoid valve
5	direct connection
6	elastic joint
7	vertical manifold
8	assembly corner piece
9	drain hoses

1.2 Rated specifications of the rack

The rack is made up of a series of manifolds, solenoid valves, nozzles, pipes and various connectors.

parameter	field
Material	Stainless steel
Width (mm/in)	573 to 2853 / 22.56 to 112.32 (minimum step 152mm/6in)
Height (mm/in)	538 to 2818 / 21.18 to 110.94 (minimum step 152mm/6in)
Depth (mm/in)	200 / 7.87 (with horizontal manifold)
NC solenoid valve	224 V 50 Hz; 1 central inlet port (IN) F G1/8" and 2 side outlet ports F G1/8": R, L. Max flow-rate with DP= 1 Bar 90 l/h; operating pressure 100 Bars
NO solenoid valve	24 V 50Hz; 1 central inlet port (IN) F G1/8" and 2 side outlet ports F G1/8": R, L. Max flow-rate with DP= 1 Bar 90 l/h; opening pressure ≤15 Bars; operating pressure 100 Bars
Water inlet connections	Female G1/4"
NO drain solenoid valves	white nylon TFN 6X8 hose (supplied by CAREL, installation by the customer)

Tab. 1.a

Note: due to the characteristics of the components, the distribution rack can be installed in the duct with a maximum air flow temperature of 60 °C.

1.3 Specifications of the droplet separators

There are two types of droplet separators made with AISI 304 stainless steel rack, which differ due to the different filtering material used:

- fibreglass;
- AISI304 stainless steel wool.

Only the versions with AISI304 filtering material are compliant with the VDI6022 standards.

The droplet separators are available in 9 different sizes, and can be combined to cover the same cross-section as the racks for distribution in the duct.

The dimensions of the droplet separators are multiples of 152 mm.

To assist the drainage of the water, ensure:

- that the holes for draining the water are free, if necessary move any filtering material that blocks them.
- that the holes for draining the water are positioned upstream of the filtering material.
- Make sure the water is drained from the support brackets, as indicated in the enclosed figures;

Seal, using material suitable for AHU ducts (not supplied by Carel), the spaces between the separators so as to prevent water from passing over the separators.

Any difference between the cross-section covered by the filters and the cross-section of the duct must be sealed so that the humidified air cannot bypass the separators; the material used must be suitable for use in AHU ducts (not supplied by CAREL).

In ducts where the air speed is higher than 2.5 m/s use two layers of separators.

When using two layers of separators:

- allow a minimum distance of at least 2 cm between the two layers of separators.
- Do not close the bottom between the two layers of separators so as to allow the water to flow down into the condensate collection tank.
- Seal any spaces between the cross-section covered by the separators and the cross-section of the duct, on both the separators upstream and downstream; the material used must be suitable for use in AHU ducts (not supplied by CAREL).

CAREL supplies modular stainless steel structures to support the separators, made up of:

- support tanks;
- shoulders;
- frames.

The sizing of the structure and the number of components is supplied by the calculation program used for sizing the distribution RACK.

N.B.: in this case too, seal any spaces between the cross-section covered by the separators and the various components of the structure with material suitable for use in AHU ducts (not supplied by CAREL), to prevent water passing the separators.

With fibreglass filtering material

code	dimensions LxHxD	rack material	filtering material	notes
UAKDS33000	456x456x70	AISI304	fibreglass	part 3 Fig. 1.b
UAKDS34000	456x608x70			
UAKDS35000	456x760x70			
UAKDS43000	608x456x70			
UAKDS44000	608x608x70			
UAKDS45000	608x760x70			
UAKDS53000	760x456x70			
UAKDS54000	760x608x70			
UAKDS55000	760x760x70			

Con filtrante lana in acciaio

code	dimensions LxHxD	rack material	filtering material	notes
UAKDS33001	456x456x70	AISI304	AISI304 steel wool	part 3 Fig. 1.b
UAKDS34001	456x608x70			
UAKDS35001	456x760x70			
UAKDS43001	608x456x70			
UAKDS44001	608x608x70			
UAKDS45001	608x760x70			
UAKDS53001	760x456x70			
UAKDS54001	760x608x70			
UAKDS55001	760x760x70			

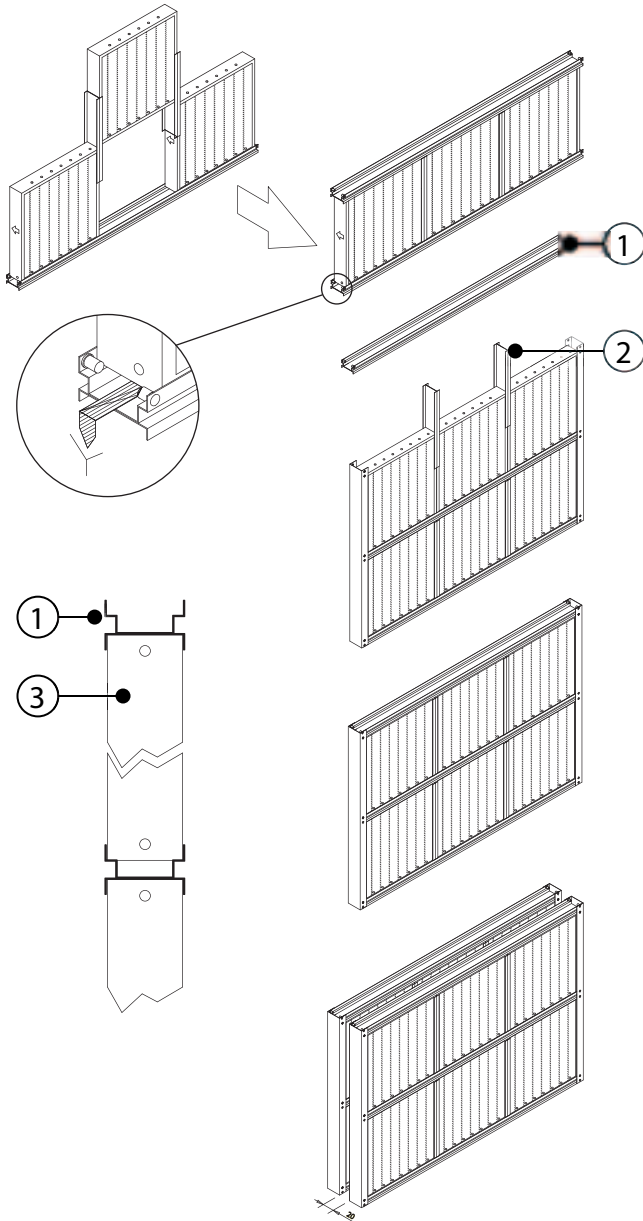
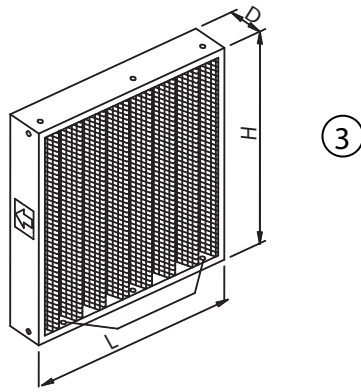

Fig. 1.b

Key:

1. drain channel;
2. module separator;
3. droplet separator module.

1.4 Components in the room distribution system

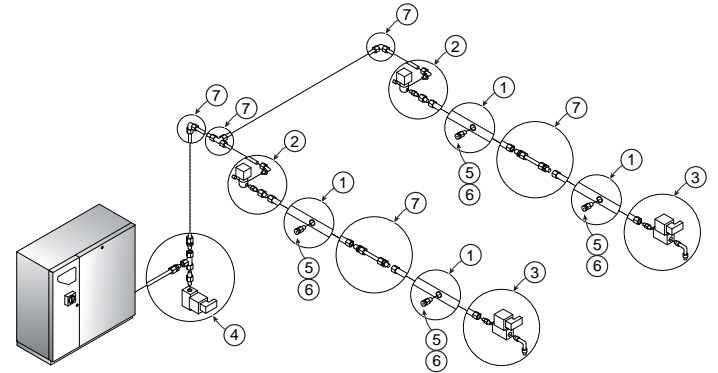

Fig. 1.c

Key:

- | | |
|----|--|
| 1. | stainless steel manifolds |
| 2. | NC on-off solenoid valve |
| 3. | NO drain solenoid valves for manifolds |
| 4. | central NO drain solenoid valve |
| 5. | nozzles |
| 6. | plugs |
| 7. | various compression fittings |

1.5 Rated specifications of the room distribution system

The distribution system is made up of a series of manifolds, solenoid valves, nozzles, pipes and various connectors.

component	material	fittings	electrical specifications	notes
Manifolds with 4 holes l=2.4 m hole step 608 mm	Stainless steel	G ¹ / ₄ "F	---	4 holes for F 1/8" NPT nozzles
Manifolds with 7 holes l=2.4 m hole step 304 mm	Stainless steel	G ¹ / ₄ "F	---	4 holes on R + 3 on L for F 1/8" NPT nozzles
NC solenoid valve	Stainless steel	G ¹ / ₈ "F	24 V 50 Hz	1 central inlet port and 2 side outlet ports for use on R, L or centre. Max flow-rate with DP= 1 Bar 90 l/h operating pressure 100 Bars
NO solenoid valves, brass	Brass	G ¹ / ₄ "F	24 V 50 Hz	For water with conductivity from 50 μS/cm to 30 μS/cm Max flow-rate with DP= 1 Bar 150 l/h operating pressure 100 Bars, opening pressure ≤15 Bars

component	material	fittings	electrical specifications	notes
NO solenoid valves, stainless steel	Stainless steel	G ¹ / ₄ "F	24 V 50 Hz	For water with conductivity less than 30 µS/cm Max flow-rate with DP= 1 Bar 150 l/h operating pressure 100 Bars, opening pressure ≤15Bars
Pipes	Stainless steel	OD 10 mm, 1 mm thick	---	
connectors	Stainless steel		---	
plugs	Stainless steel	NPT ¹ / ₈ "M	---	

Tab. 1.b

Nozzles

1.45 kg/h model [kg/h / cfh]	1.45 / 0.05 at 70 Bars / 7 MPa / 1010 PSI with 60 µm filter
2.80 kg/h model [kg/h / cfh]	2.80 / 0.10 at 70 Bars / 7 MPa / 1010 PSI with 60 µm filter
4.0 kg/h model [kg/h / cfh]	4.0 / 0.13 at 70 Bars / 7 MPa / 1010 PSI with 60 µm filter

Tab. 1.c

 **Note:** due to the characteristics of the components, the distribution rack can be installed in the duct with a maximum air flow temperature of 60 °C.

2. INSTALLATION: OPERATIONS, MATERIALS AND TOOLS, DATA REQUIRED FOR INSTALLATION IN THE DUCT OR AHU

installatore

utente

assistenza

2.1 Planning the operations

The installation operations should be performed as described below (the estimated times are approximate):

chap.	operation	estimated time	notes
3	Assembling the rack (if not already assembled)	6 hours (3 + 3)	3 hours for assembly; 3 hours for the liquid Teflon to set
5	Plumbing installation of the cabinet		
6	Positioning of the cabinet	1 hour	For installation in the duct, the operation can be performed in the 3 hours required for the Teflon to dry
7	Electrical installation of the cabinet		
9	Configuration of the controller	---	If the procedure for entering and modifying the parameters is already known, skip to chapter 8
10	Testing and commissioning the installation	1 hour	
8	Installing the rack in the duct/AHU	---	Depending on the duct/section of the AHU

Tab. 2.a

2.2 Materials and tools

Materials

- Liquid Teflon for the high pressure water connections (max. 10 MPa, 100 bar, 1450 PSI) when using demineralised water. N.B.: the limit values for demineralised water are indicated in the section on TECHNICAL SPECIFICATIONS.
- Minimum 2 brackets (or corner sections or similar components) to install the atomisation rack inside the duct/AHU.

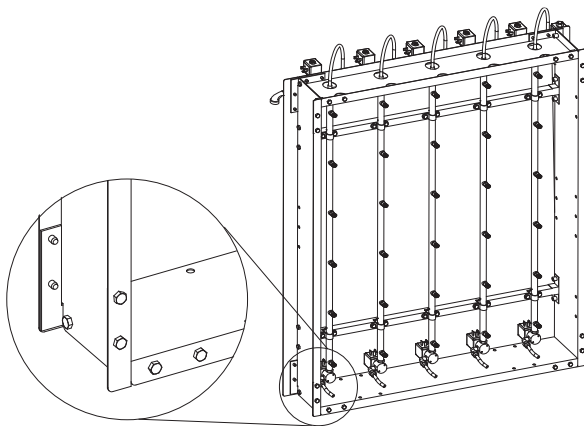

Fig. 2.a

Key:

1. steel corner section

Tools

- compressed air gun;
- set of spanners;
- set of flat-head and Phillips-head screwdrivers
- rubber mallet;
- vice (recommended);
- mechanical, plumbing and electrical tools.

2.3 Data required: configuration of the rack

⚠ Important:

- Table 2.b describes the data required for the correct assembly of the rack;
- the meaning of each row is explained in the following chapters.

Required data to be provided by the system designer

Configuration of the rack

data	value	notes
Rated flow of the rack (kg/hour)		
Maximum op. pressure (bar)		
Minimum operating pressure (bar)		
Number of atomisation circuits:		
1st circuit: number of manifolds		
1st circuit: number of nozzles		
2nd circuit: number of manifolds		
2nd circuit: number of nozzles		
3rd circuit: number of manifolds		
3rd circuit: number of nozzles		
4th circuit: number of manifolds		
4th circuit: number of nozzles		

Tab. 2.b

Additional data provided by the system designer

The installer must receive the following additional data from the designer, to complete the previous data:

1. position of the rack inside the humidification section of the duct/AHU;
2. position of the solenoid valves / direct connections;
3. position of all the manifolds in each atomisation circuit in the rack;
4. angle of each manifold from its own axis;
5. position of the nozzles and the plugs on each manifold.

If these additional data are available, add them to the table of positions shown below.

humiFog system (customer code and rack) _____

Table of the positions of the vertical manifolds, solenoid valves, nozzles, plugs

manifold circuit angle < modules	1	2	3	4	5	6	7	8	9	10	11	12	13	14	15	16	17	18
1																		
2																		
3																		
4																		
5																		
6																		
7																		
8																		
9																		
10																		
11																		
12																		
13																		
14																		
15																		
16																		
17																		
18																		

Tab. 2.c

Information for completing the table:

- the table represents a rack fitted with 18 manifolds x 18 nozzles (1974 x 2642 mm.);
- each row represents a vertical manifold;
- each "nozzle/plug" cell represents a nozzle or a plug;
- enter the data in the rows and columns that correspond to the rack in question;
- Ac: atomisation circuit that includes the vertical manifold. Indicate as 1, 2, 3 or 4. N.B.: 1= without solenoid valves; 2, 3, 4= with solenoid valves;
- -: indicate the angle of the manifold (-30°, -15°, 0°, +15°, +30°)
- nozzles/plugs: write "N" for a nozzle, "P" for a plug.

Mechanical/wiring diagram supplied with the rack

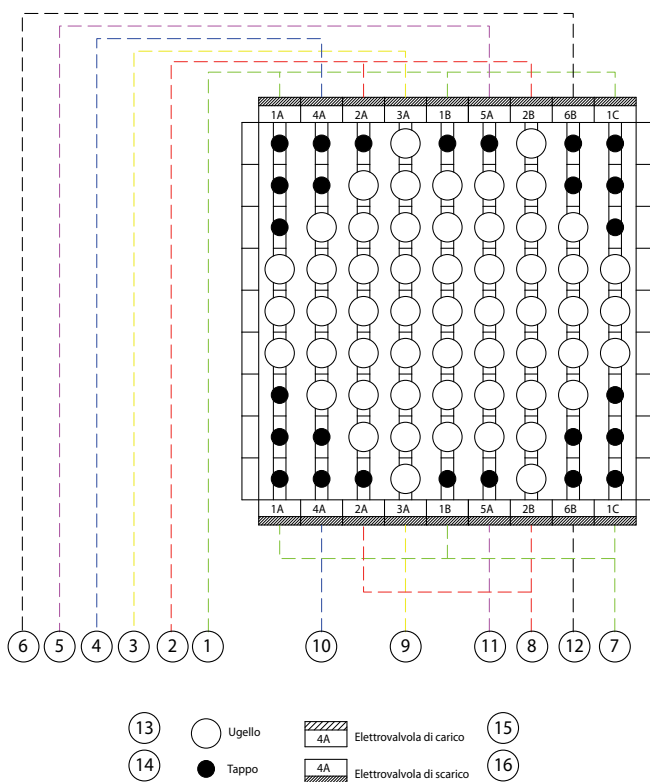

Fig. 2.b

Key

- | | |
|----|---|
| 1 | solenoid valve NC in water circuit C1, (1A 1B...) connect to the humiFog terminals labelled NC1 |
| 2 | solenoid valve NC in water circuit C2, (2A 2B...)connect to the humiFog terminals labelled NC2 |
| 3 | solenoid valve NC in water circuit C3, (3A 3B...)connect to the humiFog terminals labelled NC3 |
| 4 | solenoid valve NC in water circuit C4, (4A 4B...)connect to the humiFog terminals labelled NC4 |
| 5 | solenoid valve NC in water circuit C5, (5A 5B...)connect to the humiFog terminals labelled NC5 |
| 6 | solenoid valve NC in water circuit C6, (6A 6B...)connect to the humiFog terminals labelled NC6 |
| 7 | solenoid valve NO in water circuit C1, (1A 1B...) connect to the humiFog terminals labelled NO1 |
| 8 | solenoid valve NO in water circuit C2, (2A 2B...) connect to the humiFog terminals labelled NO2 |
| 9 | solenoid valve NO in water circuit C3, (3A 3B...) connect to the humiFog terminals labelled NO3 |
| 10 | solenoid valve NO in water circuit C4, (4A 4B...) connect to the humiFog terminals labelled NO4 |
| 11 | solenoid valve NO in water circuit C5, (5A 5B...) connect to the humiFog terminals labelled NO5 |
| 12 | solenoid valve NO in water circuit C6, (6A 6B...) connect to the humiFog terminals labelled NO6 |
| 13 | nozzle |
| 14 | plug |
| 15 | fill solenoid valve |
| 16 | drain solenoid valve |

3. ASSEMBLING THE RACK

installatore

utente

assistenza

The rack can be ordered in three configurations:

1. not assembled: in this case the assembly instructions are shown below;
2. semi-assembled: nozzles, plugs and solenoid valves are already fitted on the manifolds and tested at high pressure. The remaining parts of the rack (shoulders, vertical supports, etc.) are not assembled. The instructions for completing assembly are shown in the next few paragraphs of this chapter where, obviously, the instructions for the assembly of the plugs, nozzles and solenoid valves on the horizontal manifolds can be ignored;
3. assembled: the rack is completely assembled, ready to be installed and tested at high pressure. In this case, paragraphs from 3.3 to 3.13 can be read as information only.

Important:

- carefully read paragraphs 3.1 and 3.2;
- all the water connections must only be sealed using liquid Teflon for high pressure joints: to prevent the nozzles from blocking, do not use excessive amounts of liquid Teflon and do not use other methods for sealing the joints (for example, Teflon tape, hemp, and so on);
- use a SW10 spanner to tighten/unscrew the bolts;
- when assembly is completed, run through the checklist;
- after having completed the checklist, test the system for any water leaks and check that the solenoid valves open/close in the correct sequence (see chapter 3.1). If the rack passes the tests, install it inside the duct/AHU.

3.1 Atomisation circuits

Carefully read the following instructions!

The complete understanding of the concepts expressed in this chapter will ensure correct assembly of the rack!

Reading this chapter is absolutely not a waste of time!

DEFINITION of atomisation circuit:

1. The atomisation circuit is a series of vertical manifolds;
2. All the manifolds in each atomisation circuit start/stop the atomisation process at the same time.

PROPERTIES:

3. Each atomisation circuit is managed independently from the other circuits by the controller;
4. With the pump in constant pressure control, each individual rack can contain a maximum of 6 atomisation circuits; in the flow control configuration, the rack can contain a maximum of 4 atomisation circuits:

- C1:
 - always present;
 - all the manifolds have NC on-off solenoid valves (hereinafter "NC SV");
 - each manifold in the circuit is fitted with a drain solenoid valve connected to the part opposite to the NC solenoid valves (hereinafter "NO SV");
 - the atomisation process starts/stops when the piston pump in the cabinet starts/stops;
 - the maximum flow-rate of each manifold is 90 l/h;
 - the maximum flow-rate of each step is 120 l/h;
 - all the solenoid valves are opened/closed at the same time by the cabinet controller;;
- C2:
 - does not need to be installed;
 - all the solenoid valves are opened/closed at the same time by the cabinet controller;
- C3:
 - see C2;
- C4:
 - see C2
- C5:
 - see C2 (only for constant pressure versions);
- C6:
 - see C2 (only for constant pressure versions).

valves.

See chap. 3 paragraph 3.5 of the "Pumping unit" manual for the correct distribution of the solenoid valves.

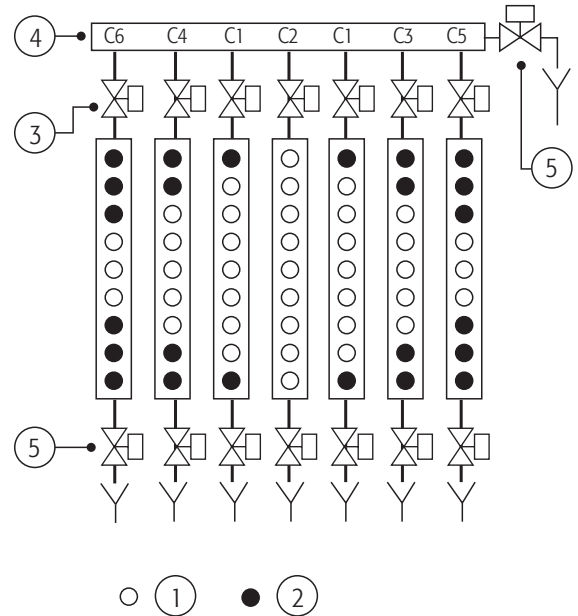

Fig. 3.a

Key:

1.	nozzles
2.	plugs
3.	NC solenoid valve (NC SV)
4.	from the pump
5.	NO solenoid valve (NO SV)

3.2 Choosing the positions of the solenoid valves, direct connections, horizontal manifolds, nozzles and plugs

Choose the positions before assembling the rack!

Continue only if the concepts expressed in the previous paragraph have been completely understood!

Carefully read the following instructions!

Reading this chapter is absolutely not a waste of time!

What does "the choice" involve?

Choosing the positions of the solenoid valves, joints, vertical manifolds, nozzles and plugs on the rack involves specifying:

1. the position of the rack inside the duct/AHU if the rack is smaller (for example, in the centre);
2. the position of all the manifolds in each atomisation circuit inside the rack;
3. the angle of each manifold from its own axis;
4. the positions of the nozzles and the plugs on each manifold (Fig. 3.b).

Note: each individual installation cannot have more than 22 solenoid

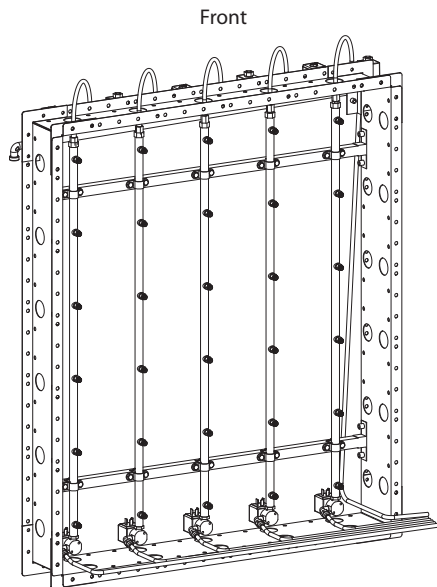

Fig. 3.b

When does the installer need to make "a choice"?

5. Has "the choice" already been made by the system designer?
 - YES: the installer needs to follow the choice made and then create the configuration of the rack and complete the table of positions, as indicated by the designer (see paragraph 2.3), after which the operations indicated in paragraph 3.3 must be completed.
 - NO: he installer needs to make "a choice": follow the instructions shown below.

How to make "a choice"

6. The installer must receive the configuration of the rack from the designer, as described in detail in paragraph 2.3.1. The following information is required for assembling the rack:
 - number of atomisation circuits;
 - number of manifolds in each circuit;
 - number of nozzles in each circuit;
7. The installer must "choose" the position of the NC solenoid valves, manifolds, nozzles and plugs on the rack based on the following criteria:
 - complete conformity with the configuration of the rack provided by the designer (do not add/remove NC solenoid valves, NO solenoid valves, manifolds, nozzles and plugs arbitrarily);
 - uniformity of atomisation inside the duct/AHU;
 - where possible, avoid atomising against any obstacles located downstream, even if these are not near the rack;
 - ease of installation and maintenance;
 - after installation, the NC solenoid valves must remain in a VERTICAL position, with the coil at the top;
8. Suggestions (see the following figure):
 - if the rack is smaller than the duct/section of the AHU, place it in the centre;
 - to prevent any obstacles downstream and to eliminate the possible creation of wet areas on the walls of the duct, where possible tilt the manifolds by -30°, -15°, +15° and +30° from their own axes. See paragraph 3.4, point 10;
 - position the manifolds in each circuit symmetrically on the rack (in reference to the horizontal axis of the rack);
 - position the nozzles in each circuit symmetrically on the rack (in reference to the horizontal and vertical axes of the rack);
 - position the nozzles in each circuit so as to avoid any obstacles downstream;
9. Choose the most suitable distribution method according to the configuration of the rack provided by the designer and complete the table of positions, as described in detail in paragraph 2.3.2.
10. The table of positions will be used when assembling the rack.

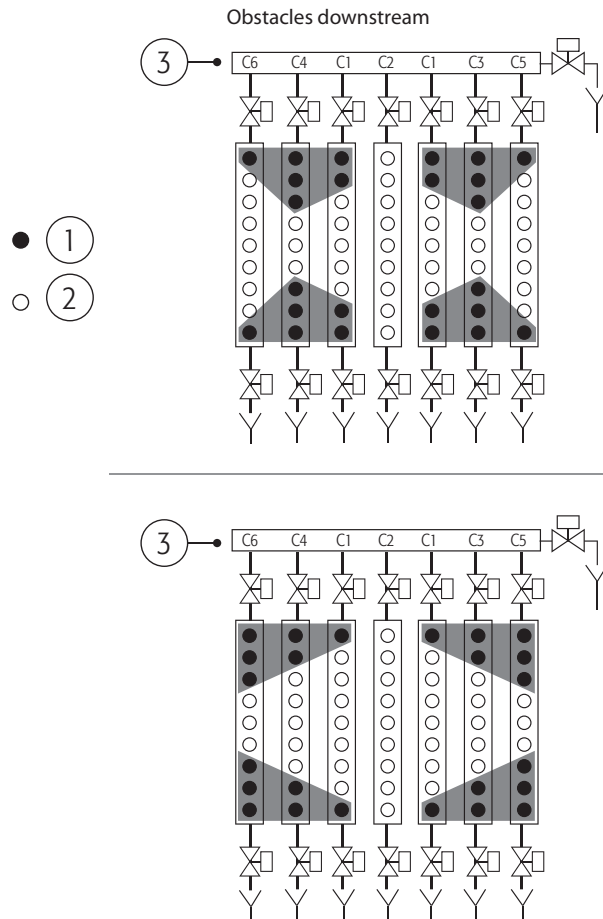

Fig. 3.c

Key:

1.	nozzles
2.	plugs
3.	NC solenoid valve (NC SV)

3.3 Assembling the main structure

The main structure of the rack is made up of:

- frame top side;
 - frame bottom side;
 - R and L shoulders;
 - manifold supports;
 - stiffening corners;
 - M6 bolts.
1. Assemble the four sides:
 - put the four sections to be assembled together.
 2. Assemble the "L" brackets on the four corners:
 - tighten the bolts marked B.
 3. Assemble the manifold support bars:
 - the side holes marked F must be facing upwards;
 - tighten the bolts marked C;
 4. The main structure is now assembled.

1

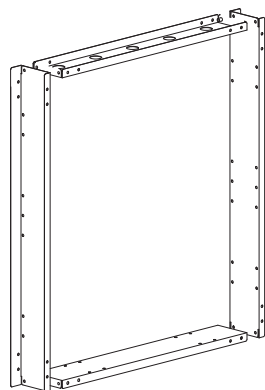

2

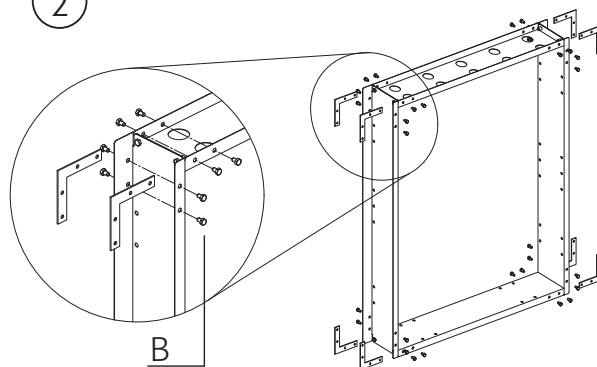

3

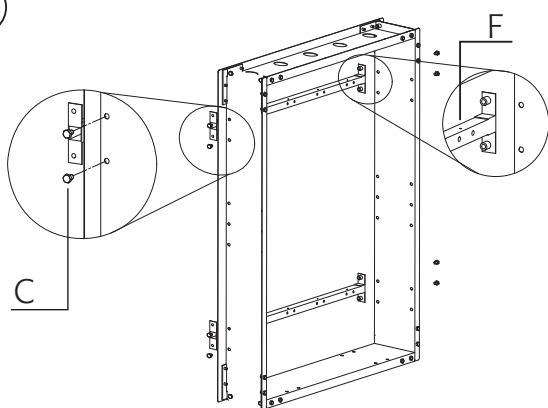

4

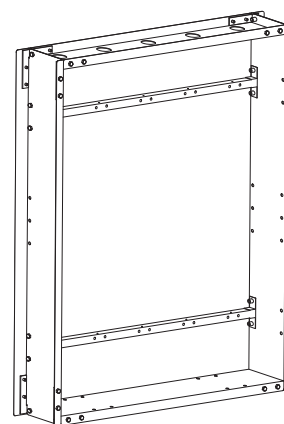

Fig. 3.d

3.4 NC/NO solenoid valve and hose assembly

Important:

There are two types of solenoid valve:

- normally closed solenoid valves (NC)
- normally open solenoid valves (NO)

The differences between the two types of solenoid valve are:

- differently shaped pilots;
- different tightening screws between the coil and pilot;
- coil with different hole in the centre.

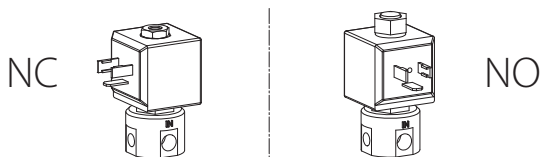

Fig. 3.e

Normally closed solenoid valves (NC SV)

These solenoid valves are fitted on the horizontal manifold and connected to the vertical manifold via a hose.

They have three female G1/8" fittings; the centre connection marked "IN" is connected directly to the horizontal distributor using a G1/8" nipple. The remaining R and L side fittings are two outlets that can be used indifferently, according to the position of the solenoid valve inside the rack. Connect one of the two outlets to the hose, and close the other

using a male G1/8" plug.

To ensure correct operation, these solenoid valves must be fitted with the coil in the vertical position and facing upwards.

Assembling the NC solenoid valves:

1. Remove the coil from the NC solenoid valve:
 - use an SW13 spanner;
2. Close the outlet on the side that is not used
 - use an M G1/8" plug;
 - use liquid Teflon (not in excessive quantities);
 - do not tighten excessively;
3. Connect the open outlet
 - use a M G1/8" x M12 x 1.5 nipple (supplied with the 1/8" hose);
 - use liquid Teflon (not in excessive quantities);
 - do not tighten excessively;
4. Connect the horizontal manifold
 - use a G1/8" nipple;
 - connect to the inlet (centre hole);
 - use liquid Teflon (not in excessive quantities);
 - do not tighten excessively.

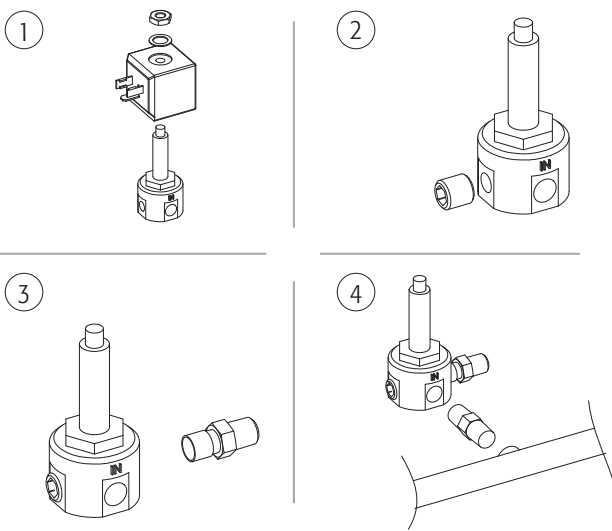

Fig. 3.f

Normally open solenoid valves (NO SV).

These solenoid valves are fitted on both the horizontal manifolds and the vertical manifolds.

In the horizontal manifold they are fitted, in a vertical position, by connecting the inlet on the solenoid valve to the male G1/8" fitting. The outlets should be connected to a drain and can be used either both or individually, plugging the unused outlet.

In the vertical manifolds they are fitted in a horizontal position by connecting the inlet of the solenoid valve to the male G1/8" fitting. The outlets should be connected to a drain and can be used either both or individually, plugging the unused outlet.

To simplify the layout of the various outlets for draining the water on each solenoid valve, M G1/8" elbows are provided for the 6x8 Rilsan tubing, supplied.

Assembling the NO solenoid valves

1. Remove the coil from the NO solenoid valve
 - use an SW16 spanner;
2. Close the outlet on the side that is not used
 - use an M G1/8" plug;
 - use liquid Teflon (not in excessive quantities);
 - do not tighten excessively;;
3. Connect the NO solenoid valve to the male G1/8" fitting on the horizontal manifold
 - use liquid Teflon (not in excessive quantities);
 - do not tighten excessively;
4. Connect the NO solenoid valve to the male G1/8" fitting on the vertical manifold
 - use liquid Teflon (not in excessive quantities);
 - do not tighten excessively;
5. Connect the drain to the NO solenoid valve outlet
 - cconnect an M/F G1/8" elbow;
 - use Teflon or sealant for water at low pressure.

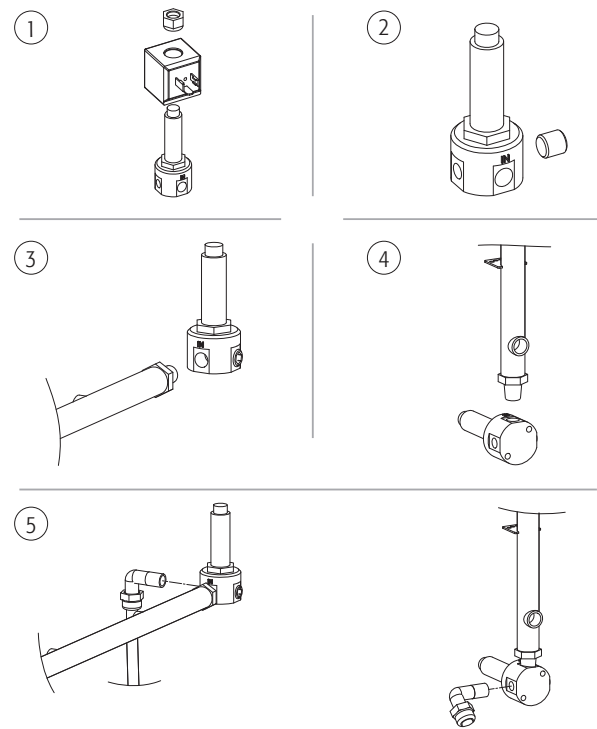

Fig. 3.g

Hoses

The connection between the NC solenoid valves/elbow connectors and the vertical manifolds uses 1/8" hoses, complete with conical G1/8" x M12.5 x 1 nipples.

The two nipples are connected one to either outlet of the NC solenoid valve/elbow connector and the other to the inlet of the vertical manifold.

Once the manifolds and distributor have been positioned on the rack, connect the remaining part of the hose to the corresponding nipples.

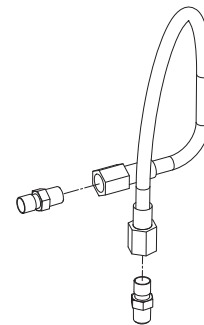

Fig. 3.i

3.5 Assembling the manifolds

Assembling the horizontal manifolds

Important: this phase refers to the table of positions, described in detail in paragraph 2.3.2.

Note: the L side has been used as the standard for the inlet, while the R side will be fitted with the NO solenoid valve. If due to special need the standard positions need to be reversed, putting the inlet on the R and the solenoid valve on the L, this must be done in this phase, as doing it later on will require the horizontal manifold to be reassembled.

- connect the supply to the NO solenoid valve at the end of the manifold with a male G1/8" fitting; the final position of the solenoid valve must be vertical and on the R side of the horizontal manifold;
- connect the M/F G1/4" elbow connector to the L end of the manifold with an F G1/4" fitting;
- connect the NC solenoid valves as shown in the table of positions;
- connect the direct connections as shown in the table of positions;
- plug the holes that are not used with the G1/8" plugs.

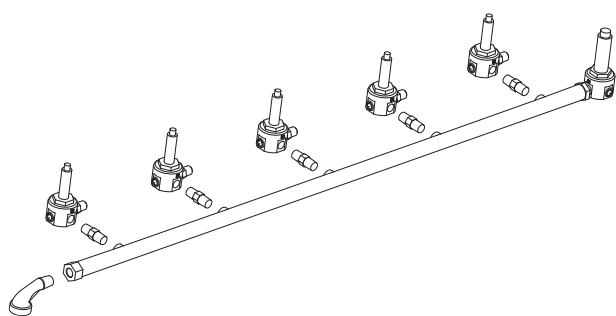

Fig. 3.j

Assembling the vertical manifolds

Important: this phase refers to the table of positions, described in detail in paragraph 2.3.2.

- connect the nozzles as shown in the table of positions.
- plug the holes that are not used with the G1/8" plugs.
- connect the supply to the NO solenoid valve at the end of the manifold with a male G1/8" fitting
- connect the 1/8" hose connector to the end of the manifold with an F G1/8" fitting

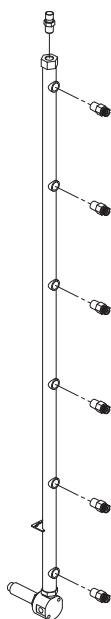

Fig. 3.k

3.6 Assembling the manifolds in the rack

Assembling the vertical manifolds in the rack

Important: this phase refers to the table of positions, described in detail in paragraph 2.3.2.

N.B.: if there are obstacles in front to the nozzles that may cause the atomised water to condensate, the manifold can be rotated $\pm 30^\circ$ in steps of 15° . The angle of the manifold, when used, is shown in the table of positions.

- place the manifold in the rack from the front;
- position and install the angle adjustment bracket onto the bottom fastening bar (Fig. 3.n);
- fasten the manifold to the horizontal bars using the U-bolts (S);
- tighten the bolts marked D, however without tightening them completely, making sure that that the angle adjustment bracket is rested correctly on the bottom fastening bar;
- if the angle of the manifold shown in the table of positions is equal to 0° , tighten screw P (use a PH0 screwdriver) through the centre hole of the angle adjustment bracket and completely tighten the bolts marked D (Fig. 3.o);
- if the angle of the manifold shown in the table of positions is other than 0° tighten screw P (use a PH0 screwdriver) through the hole corresponding to the required angle, then completely tighten the bolts marked D (Fig. 3.p).

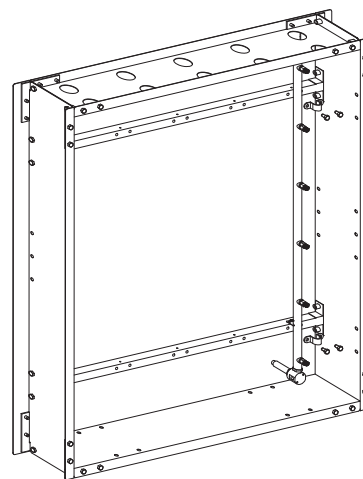

Fig. 3.l

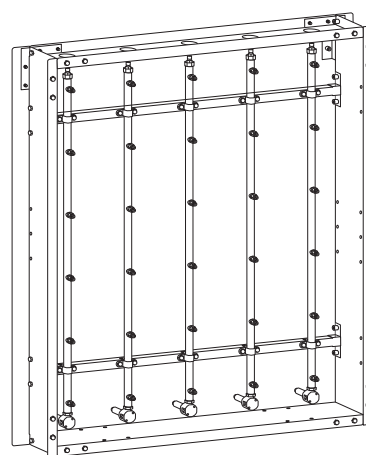

Fig. 3.m

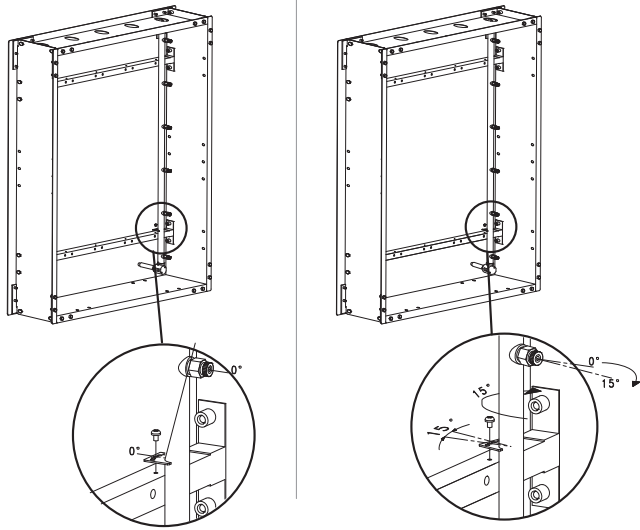

Fig. 3.n

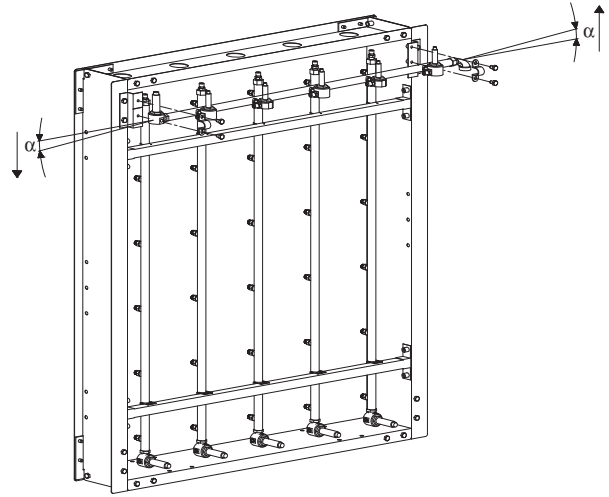

Fig. 3.p

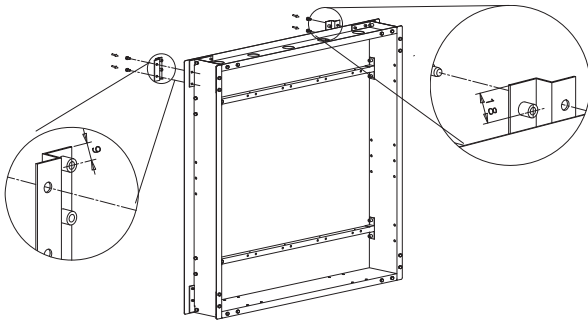

Fig. 3.o

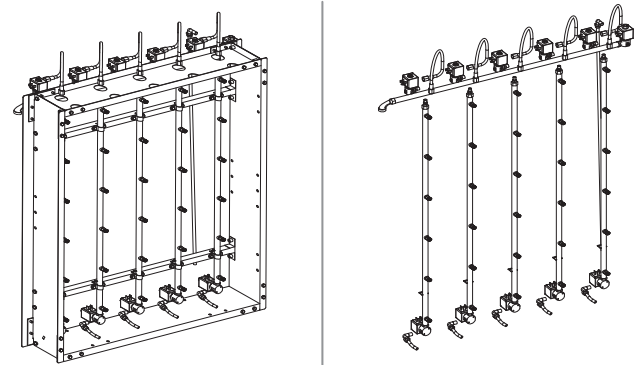

Fig. 3.q

Assembling the horizontal manifold to the rack

This is installed at the rear of the rack using two support brackets and U-bolts.

To ensure drainage, the distributor must be installed at a certain slope, which is ensured by the special shape of the support brackets.

If the position of the drain solenoid valve is reversed, than the brackets must also be reversed (Fig. 3.q).

Assembly sequence:

- fasten the support brackets to the rack using the corner section screw;
- fasten the distributor to the brackets using the U-bolts;
- check the slope of the NO solenoid valve (Fig. 3.r) (the valve must be higher than the inlet to the horizontal distributor);
- connect the hoses between the NC solenoid valve, direct connections and vertical manifolds, passing through the holes of the frame top side.

3.7 Rack assembly: checklist

humiFog SYSTEM NAME: _____

√	Description	Notes
	NC and NO solenoid valves: positioned correctly with their coils	
	NC solenoid valves: connected to the horizontal manifold with the inlets in the centre	
	NC solenoid valves: coil in vertical position	
	NO solenoid valves: connected to the horizontal and vertical manifolds with the inlets in the centre.	
	Manifold support bars: the holes are on the top	
	Rack positions: as shown in the table of positions or on the mechanical/wiring diagram supplied	
	connect TFN drain hoses to the NO solenoid valves	

4. INSTALLING THE RACK IN THE DUCT

4.1 Connecting the cabinet to the rack

Important:

- the connection must be rated for an operating pressure of at least 100 bars (10 MPa, 1450 PSI);
- there must be at least a 1 m section of hose;
- all the metal parts must be stainless steel.

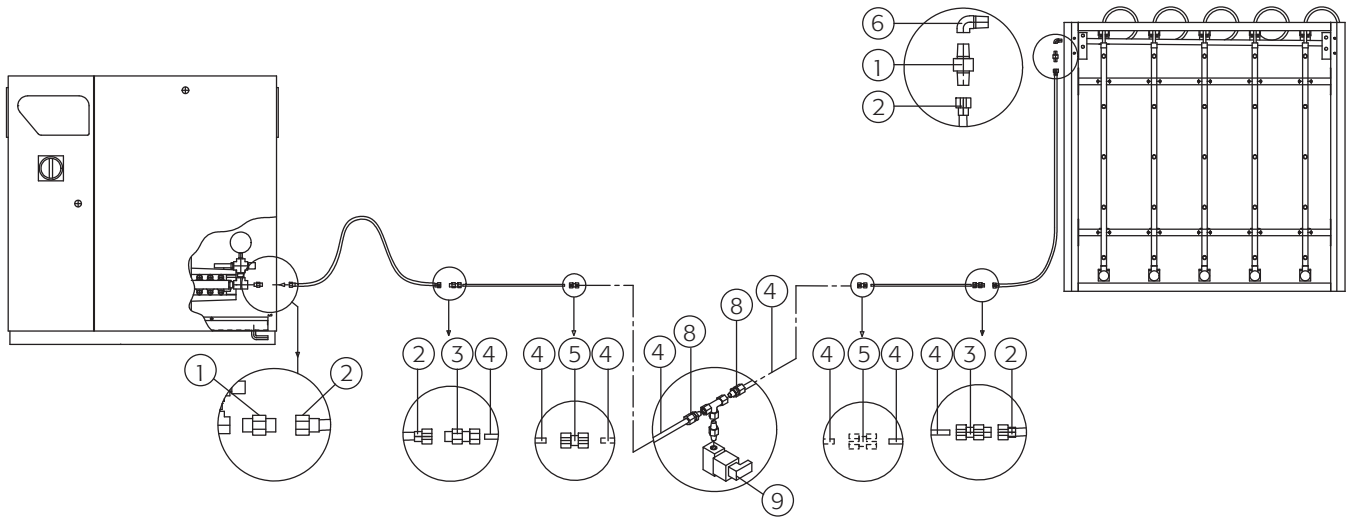

Fig. 4.a

Key:

- | | |
|----|---|
| 1. | G3/8" x M16 x 1.5 nipple (supplied with the pump and to be used with CAREL connection kit); |
| 2. | hose L=2 m with F M16 x 1.5 fittings, fitted with "O-ring" (supplied in the following kits: UAKT100000; UAKT200000; UAKT400000); |
| 3. | M G1/4" x dia. 10 compression fitting (supplied in the following kits: UAKTD14000; UAKTD30000). |
| 4. | AISI 304 dia. 10 pipe, L= 1.5 to 3 m (supplied in the following kits: UAKTD30000; UAKT030000; UAKT030000; UAKT012000; UAKT018000); |
| 5. | compression fitting for dia. 10 pipe (supplied in the following kits: UAKTD00000; UAKTD30000); |
| 6. | F G1/4" elbow (supplied with the rack) |
| 7. | G1/4" x M16 x 1.5 nipple (supplied with the following kits: UAKT100000; UAKT200000; UAKT400000).
N.B.: ALL THE COMPONENTS ARE APPROVED TO 100 BARS |
| 8. | M G 1/4" adapter kit for dia. 10 pipe |
| 9. | NO valve kit for draining the line |

1. CAREL hose kit:

- if using the CAREL hose kit, only the connection requires liquid Teflon (ref. "8" and "9" Fig.4.a);
- do not tighten excessively;

2. Hoses and adapters not specified:

- use liquid Teflon for the threaded connections;
- do not use liquid Teflon for non-threaded connections and connections with O-rings;
- carefully tighten the hose connections (do not tighten excessively)

3. The nipple (ref. "1") is supplied with the humiFog cabinet, and is to be used with the connection kit supplied by CAREL; if using connections with different standards, check compatibility;

4. The 90° elbow (ref. "6") is part of a standard rack.

4.2 Junction box

1. Connecting the solenoid valves:

use the optional junction box to connect the solenoid valves in the same atomisation circuit in parallel.

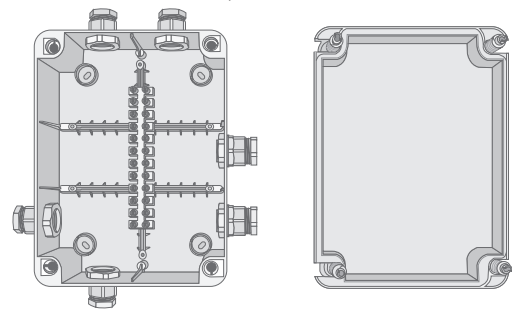

Fig. 4.b

4.3 Installing the rack in the duct/AHU

- install the rack by fastening at least two opposing sides to the duct/AHU;
- use corner sections for fastening the rack (the bolts can be used as shown in the drawing below) or slide into two stainless steel U-shaped sections;

N.B.: the corner sections and the stainless steel U-shaped sections are not supplied by CAREL.

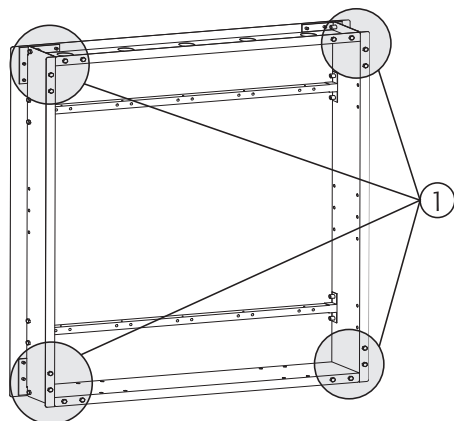

Fig. 4.c

Key:
1. bolts

4.4 Checklist for rack installation in the duct

humifog system name: _____

√	Description	Notes
	Connections: all parts tested to 100 bar. The hose is fitted.	
	Metal parts in stainless steel.	
	Connection hose: connected between the cabinet and the rack	
	Junction box: installed and correctly connected (if used)	
	The rack is fastened in the duct/AHU on at least two opposing sides	
	Droplet collection tank installed across the entire humidification section	
	Droplet separator installed at the end of the humidification section	

Date: _____

Signature: _____

5. PREVENTIVE MAINTENANCE OF THE DISTRIBUTION SYSTEM

installatore

utente

assistenza

with the national standards on maintenance (ASHRAE 12-2000, VDI 6022, etc.).

The purpose of the maintenance operations is to ensure the correct operation of the unit, that is:

- identify any water leaks;
- identify any blocked nozzles;
- identify any blocked valves.

To do this, the system must be operated manually; see the next paragraph.

For the manual start-up procedure, see paragraph "sub menu 4. manual procedures" in the "Pumping unit" manual

5.1 Maintenance menu

Important: the operations described in this menu must only be carried out by qualified personnel.

From the main screen press:

- PRG to access the main menu;
- DOWN to move to the maintenance menu;
- ENTER to move to the password;
- UP/DOWN to enter the password "77"
- ENTER to access the selected menu;
- UP or DOWN to move between the submenus;
- ENTER to select the parameter and move between the parameters;
- UP/DOWN to modify the parameter;
- ENTER to confirm the selected parameter and go to the next parameter;
- ESC to return to the previous menu.

Maintenance menu screens:

Display
1. Reset conf
2. System info
3. Instant readings
4. Manual procedure
5. System status info
6. Hour counter
7. Alarm log

Submenu 4. Manual procedure

Used to manually set the humiFog outputs, one at a time. The parameters displayed correspond to the humiFog terminal labels. In addition, the capacity to be generated can be set for a zone or the entire system.

Display	description	range	unit
Manual procedure	heading		
System prod request	Capacity that the system must generate. e.g. setting this to 30%, all the zones will generate 30% of maximum capacity.	0 to 100	%
Zone prod request	Capacity that the zone must generate. e.g. setting this to 30%, the zone will generate 30% of maximum capacity.	0 to 100	%
Manual control all I/O	Manual setting of all the humiFog inputs and outputs		

Tab. 5.a

5.2 Preventive maintenance of the accessories

Droplet collection tank

- this must be installed so that it covers the entire surface of the humidification section. It must have a downwards slope so as to immediately drain any water and prevent stagnation. Clean the mineral deposits from the tank when needed.
- the tank must ensure the immediate drainage of all the water not absorbed by the air;
- make a slope of 1° to assist drainage.

Droplet separator

- this must be in the correct position and cover the entire surface of the section;
- check that the droplet separator is clean. If it contains a high quantity of mineral salts, it must be replaced. Check that the pressure drop across the droplet separator is not too high. If the pressure drop is much higher than the value measured during the installation of the droplet separator, it should be replaced;
- ensure a slope of 1° to assist drainage.

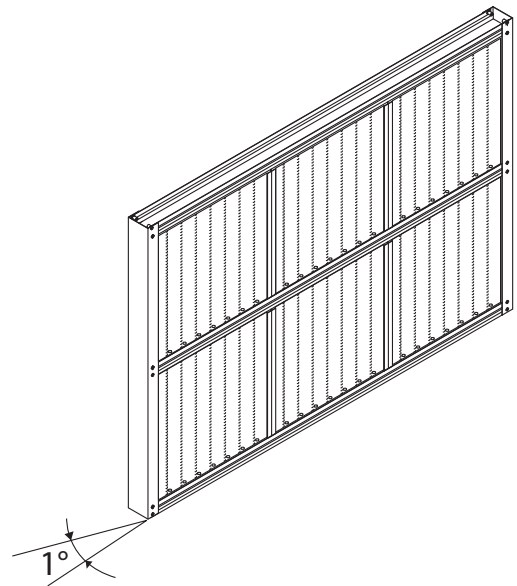

Fig. 5.b

6. OPERATIONS, MATERIALS, TOOLS AND DATA REQUIRED FOR INSTALLING THE ROOM DISTRIBUTION SYSTEM

The installation operations should be performed as described below (the estimated times are approximate)

chap. (pump unit man.)	operation	estimated time	notes
4	Assembling the distribution system	---	Depending on the size
12	Plumbing installation of the cabinet		
13	Positioning of the cabinet Electrical installation of the cabinet	1 hour	
19	Configuration of the controller		If the procedure for entering and modifying the parameters is already known, skip to chapter 10
16	Testing and commissioning the installation	1 hour	Connect the rack or the distribution system and check water-tightness and correct operation

Tab. 6.a

6.1 Materials and tools for installation in the room

- liquid Teflon for the high pressure water connections (max. 10 MPa, 100 bar, 1450 PSI) when using demineralised water. N.B.: the limit values for demineralised water are indicated in Table 9.1.1 of the "technical specifications" manual;
- one external tap for the demineralised water to be connected to the cabinet inlet (recommended). N.B.: the cabinet inlet connection involves attaching the connector to the pressure regulator inlet (for the sizes of the fittings, see Table 11.c and 11.d in the "pumping unit" manual);
- supports for the wall or ceiling mounting of the system of manifolds and pipes, i.e. collars with expansion plugs or the like.

6.2 Assembling the distribution system in the room

Data for determining the components

Main rules for sub-dividing the flow-rates between the branches:

1. the sum of the flow-rates of the atomisation manifolds must be $\geq 50\%$ of the flow-rate of the pump;
2. the branch that is always open, i.e. not shutoff by an NC solenoid valve, must have a flow-rate that is $\geq 25\%$ of the flow-rate of the pump;
3. each drain solenoid valve cannot handle more than 300 l/h ($\Delta P = 4$ Bars).

The designer should provide drawing with the physical layout of the humidification system inside the environment being humidified and the individual positions of the nozzles with their angle and direction of atomisation. If this is not available, a drawing should be prepared before installation according to the type of room and the equipment found inside: lights, columns and other structures that must be kept in consideration when preparing the diagram for positioning the nozzles.

The minimum free space in front of the nozzle must be around 2.5 m, with the position of the nozzles depending greatly on the presence of any obstacles that may be in the trajectory of the atomised water. Fig. 7.a (typical layout of the nozzles) can be used as a guide for identifying the various components. These drawings should show the list and the

number of the components, ensure their clear identification with the name and where necessary code of the various items, the clearances or play required for assembly, the identification of the zones and any comments on the position of the nozzles.

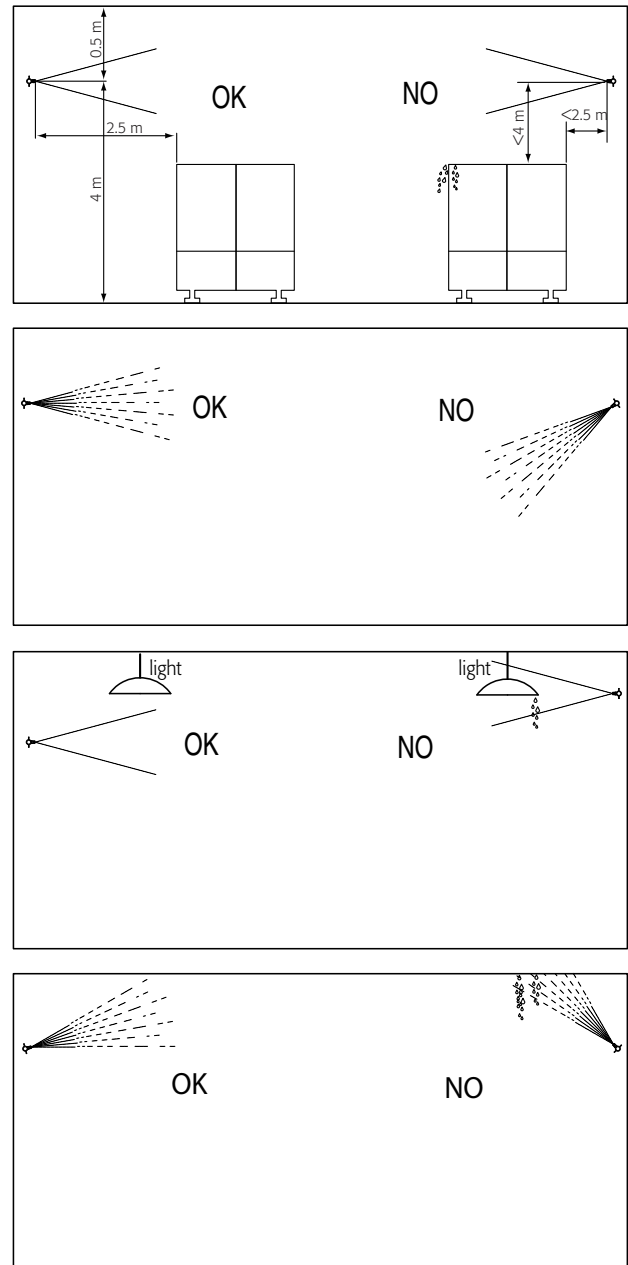

Fig. 6.a

The following are required for installation:

- the positions of the support attachments: on the walls, ceilings or other structure, used to fasten the distribution system in the room, with a height of at least 4.0 m* above any obstacles and a distance of at least 0.5 m from the ceiling;
- water connections to the pump and the components in the system (see Table 11.c, 11.d and 11.j in the "pumping unit" manual);
- electrical connections to the pump and components in the system (see Table 11.f, 11.g and 11.j of the "pumping unit" manual);
- cutting and joining of stainless steel pipes using standard plumbing systems and tools.

The installer must have all the equipment and the skills required to perform the plumbing and electrical operations for the correct assembly of the system.

*: average value with humidity set point 60 % rH at 20 °C; with higher humidity set point values, the height above the floor should be increased.

Atomisation circuits

The atomisation circuit consists of a set of manifolds, nozzles, solenoid valves, compression fittings and connection pipes or hoses. All the nozzles in an individual atomisation circuit start and stop the atomisation process at the same time.

Atomisation circuit without on-off valves

This is a circuit where there is no on-off solenoid valve and the nozzles in the circuit start atomising when the pump starts, and stop atomising when the pump stops.

This type of circuit is used:

- in simple installations with one atomisation circuit;
- in installations with more than one atomisation circuit, as the first open atomisation circuit.

N.B.: this circuit always includes the drain solenoid valve at the end of the line to allow the pipes to be automatically emptied/washed.

Atomisation circuit with on-off valves

This is a circuit featuring on-off solenoid valves and the nozzles in the circuit start atomising when the on-off solenoid valve opens, and stop atomising when the valve closes.

This type of circuit is used in installations with more than one atomisation circuit.

N.B.: this circuit always includes the drain solenoid valve at the end of the line to allow the pipes to be automatically emptied/washed.

Components in the atomisation circuit

The following components are available for the construction of the distribution system:

- **Stainless steel manifolds** dia. 16 mm (1/2") with threaded holes on one side only for fitting up to 4 nozzles, and F G1/4" terminal fittings for connection to the next manifold or a drain or on-off solenoid valve. The length of the manifolds is 2.5 m, and they feature a reduced number of fittings and assembly operations to simplify installation. Additional manifolds can be connected using the high pressure connections supplied as accessories;
- **Stainless steel manifolds** dia. 16 mm (1/2") with threaded holes on both sides for fitting 7 nozzles (4 L + 3 R) and F G1/4" terminal fittings for connection to the next manifold or a drain or on-off solenoid valve. The length of the manifolds is 2.5 m, and they feature a reduced number of fittings and assembly operations to simplify installation. Additional manifolds can be connected using the high pressure connections supplied as accessories;
- **Stainless steel NC capacity-control solenoid valve kit** 24 V 50 HZ with 1 inlet at the front, F G1/8", and 2 outlets on the side, in line, with F G1/8" fittings. Rated flow 90 l/h with ΔP= 1 Bar. The kit includes: solenoid valves, stainless steel fittings for direct connection to the manifolds and DIN connector for the electrical connection;
- **Brass NO drain solenoid valve kit for manifolds** 24 V 50 HZ with F G1/4" fittings. Rated flow 150 l/h with ΔP= 1 Bar. The kit includes: solenoid valves, stainless steel fittings for direct connection to the manifolds, elbow drain connector for Rilsan 8x6 tubing and DIN connector for the electrical connection;
- **Stainless steel NO drain solenoid valve kit for manifolds (for very aggressive water)** 24 V 50 HZ with F G1/4" fittings. Rated flow 90 l/h with ΔP= 1 Bar. The kit includes: solenoid valves, stainless steel fittings for direct connection to the manifolds, elbow drain connector for Rilsan 8x6 tubing and DIN connector for the electrical connection;
- **Various stainless steel compression fittings for dia. 10 pipe;**
- **Nozzles:** for the distribution of the atomised water;
- **1/8"NPT plugs:** if the number of nozzles used is less than the number of holes available on the manifolds;
- **G 1/4" nipple:** for the direct connection of two manifolds;
- **10 mm diameter connection kit:** available in 3 m sections with packages of 1, 3, 4 and 6 pipes (these are extensions where nozzles cannot be fitted).

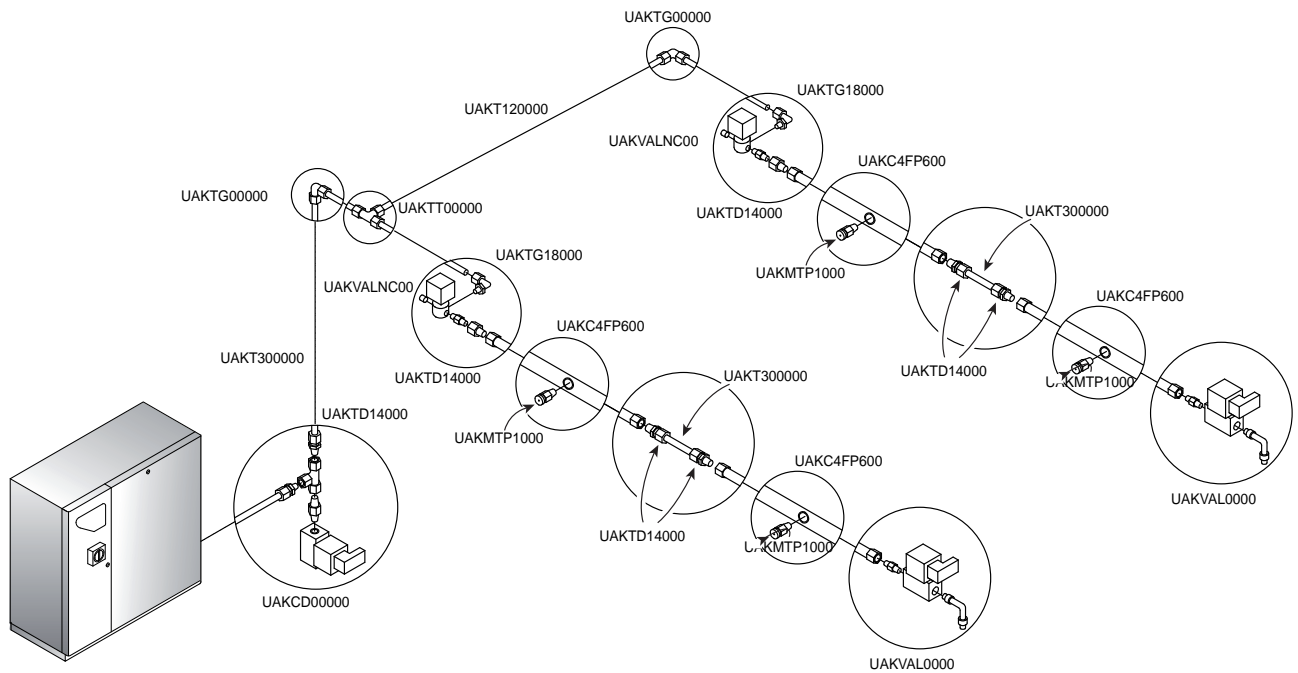

Fig. 6.b

Installation of the distribution system

The system supply lines must be kept clean and free of obstructions.

The water distribution pipes must be installed level along the walls, on columns or hanging from the ceiling.

Avoid running the lines above equipment or areas that are hard to access.

Choose the best method for running the supply pipes to the system; this may include hanging the lines using threaded rods, in which case they must be well secured.

Any pockets of air trapped inside the manifolds will bring about the slow discharge of the pressure in the system when the pump stops, causing the nozzles to drip. For this purpose, the drain solenoid valves supplied in the various kits should be used.

On the supply lines to the nozzles, using compression fittings, and make sure the fittings and pipes are made from the same material (never use brass fittings with stainless steel pipes, as this will not seal well). When installing the hanging supply lines, make sure all local building regulations are complied with. When installing the lines, the maximum distance between one support and the next should not exceed 1.5 m; use terminals that are suitable for the diameter of the pipes and make sure that these prevent rotation or twisting.

N.B.: before assembling the distribution system, remove all burrs from the pipes and hoses and make sure that they are clean; if necessary, remove any impurities and dust by blowing with compressed air.

Standard compression fittings for 10 mm diameter, 1 mm thick pipe, specifically for high pressure are supplied for joining the manifolds in the field (always use fittings with the same features).

For the correct assembly of the fittings supplied, proceed as follows:

1. Insert the pipe fully into the fitting, completely tighten the fastening nut, without however over-tightening;
2. make a mark on the nut;
3. secure the body of the fitting with a spanner, then tighten the nut 1/4 of a turn.

Note: to dismantle the fitting simply unscrew the nut a 1/4 of a turn.

For the 10 mm pipe, when assembling, tighten the fitting with the correct force, as this is very important for the seal of the joint.

The two figures on the side show examples of distribution systems in the room.

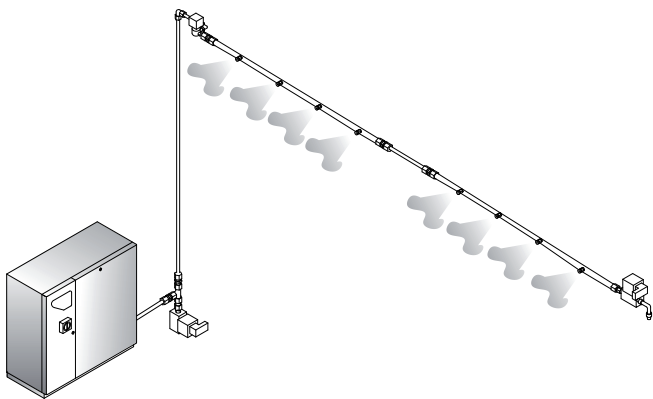

Fig. 6.c

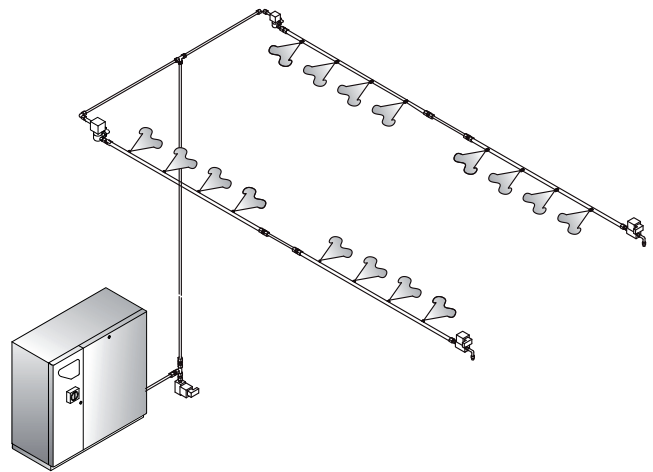

Fig. 6.d

Connecting the cabinet to the distribution system

Important

- the connection must be rated for an operating pressure of at least 100 bars (10 MPa, 1450 PSI);
- there must be at least a 1 m section of hose.

1 CAREL hose kit

- If using the CAREL hose kit, use liquid Teflon for the fittings and threaded connections
- Do not use liquid Teflon for non-threaded connections and connections with O-rings.
- For fastening the compression fittings, see chap. 6.2.6
- Refer to the spare parts manual for a list of hoses and pipes available.

Electrical connection of the solenoid valves

Terminals are available in the electrical panel for connecting the solenoid valves in each atomisation circuit with on-off valves in the distribution system.

- **Terminal NC1:** Connect the NC capacity-control solenoid valve in the first atomisation circuit to this terminal;
- **Terminal NC2:** Connect the NC capacity-control solenoid valve in the second atomisation circuit to this terminal;
- **Terminal NC3:** Connect the NC capacity-control solenoid valve del terzo atomisation circuit to this terminal;
- **Terminal NC4:** Connect the NC capacity-control solenoid valve in the fourth atomisation circuit to this terminal;
- **Terminal NC5:** Connect the NC capacity-control solenoid valve in the fifth atomisation circuit to this terminal;
- **Terminal NC6:** Connect the NC capacity-control solenoid valve in the sixth atomisation circuit to this terminal;
- **Terminal NO1:** Connect the NO drain solenoid valve in the first atomisation circuit to this terminal;
- **Terminal NO2:** Connect the NO drain solenoid valve in the second atomisation circuit to this terminal;
- **Terminal NO3:** Connect the NO drain solenoid valve in the third atomisation circuit to this terminal;
- **Terminal NO4:** Connect the NO drain solenoid valve in the fourth atomisation circuit to this terminal;
- **Terminal NO5:** Connect the NO drain solenoid valve in the fifth atomisation circuit to this terminal;
- **Terminal NO6:** Connect the NO drain solenoid valve in the sixth atomisation circuit to this terminal;
- **Terminal NOL:** Connect the drain solenoid valve in the main water line between the pumping unit and distribution system;
- **G0B:** Connect the neutral of all the solenoid valves.

See chapter 3.5 "Connecting the solenoid valves" in the "Pumping unit" manual.

CAREL

CAREL INDUSTRIES - Headquarters
Via dell'Industria, 11 - 35020 Brugine - Padova (Italy)
Tel. (+39) 049.9716611 - Fax (+39) 049.9716600

Agenzia / Agency: