



Non-penetrative supports for pipework, duct and cable tray

The Multi Foot is designed to be a multipurpose support for duct, pipework and cable trays or any combination of these.

This extremely versatile and cost-effective one-piece support is available in two sizes with optional rubber mats or the new integrated mat configuration.

Multi Foot Packs with adhered mat

- Versatile application
- Quick & easy installation
- Accepts a full range of strut sizes
- Compatible with industry standard componentry
- Rigid nylon foot
- Supplied with adhered rubber mats for optimum roof protection
- Boxed for convenience

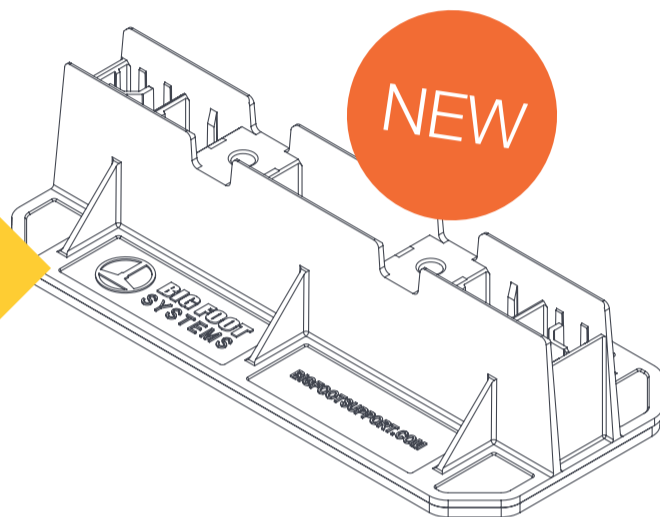

PRODUCT INFORMATION

Model	400mm 4 Pack	600mm 3 Pack
Part no.	B9640	B9655
Height (mm)	80	80
Width (mm)	180	220
Length (mm)	400	600
Max. load per foot (kg)	259	474
Packaged weight (kg)	6.8	7.5

PLEASE NOTE: Multi Foot is supplied WITHOUT any fixings or fittings

MULTI FOOT APPLICATIONS

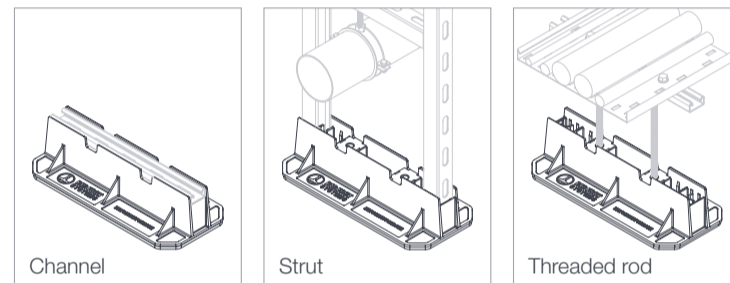

Multi Foot separates

- Versatile application
- Quick & easy installation
- Accepts 41mm strut
- Compatible with industry standard componentry
- Rigid nylon foot
- Optional rubber mats for optimum roof protection

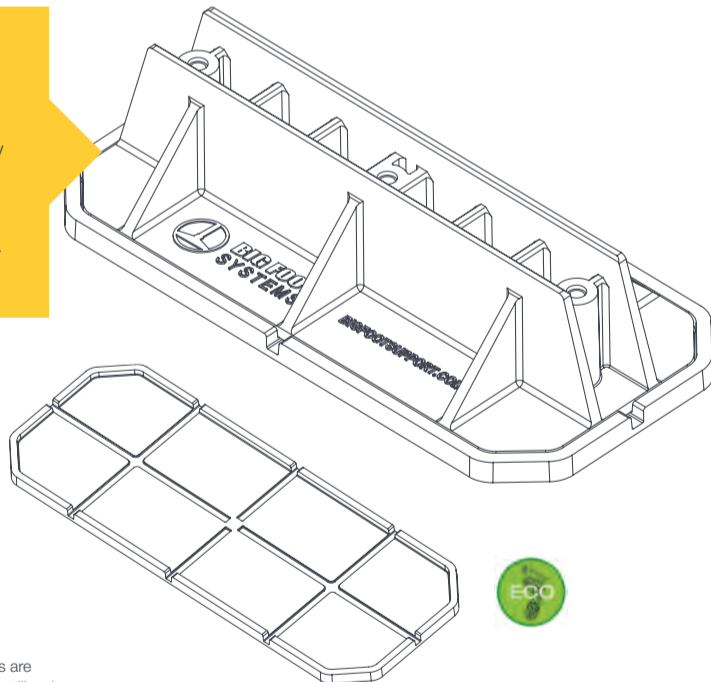

For ease of specification these products are detailed on the following building product libraries:



PRODUCT INFORMATION

Model	400mm	600mm	400mm Mat	600mm Mat
Part no.	B6357	B6359	B6358	B6360
Height (mm)	95	95	10	10
Width (mm)	180	220	185	225
Length (mm)	400	600	405	605
Max. load per foot (kg)	259	474	-	-
Packaged weight (kg)	1.7	2.8	2.5	4.5

PLEASE NOTE: Multi Foot is supplied WITHOUT any fixings or fittings

MULTI FOOT APPLICATIONS

