

Spring return actuator for the operation of air dampers that perform safety functions (e.g. frost and smoke protection, hygiene, etc.) for building services installations

- For dampers up to approx. 0.4 m²
- Torque 2 Nm
- Nominal voltage AC/DC 24 V
- Control: Open-close
- Integrated auxiliary switch

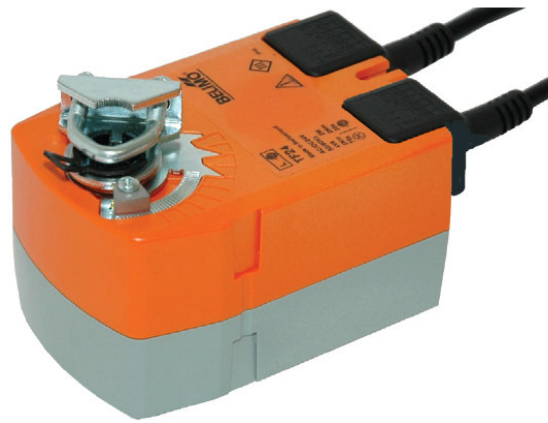

Technical data

Electrical data	Nominal voltage	AC 24 V, 50/60 Hz DC 24 V	
	Nominal voltage range	AC 19.2 ... 28.8 V DC 21.6 ... 28.8 V	
	Power consumption	In operation 2.5 W @ nominal torque At rest 1.5 W For wire sizing 5 VA	
	Auxiliary switch	1 x SPDT 3 (0.5) A, AC 250 V <input type="checkbox"/> (Switching point adjustable 0 ... 100% \triangleleft)	
	Connection	Motor Cable 1 m, 2 x 0.75 mm ² Auxiliary switch Cable 1 m, 3 x 0.75 mm ²	
	Functional data	Torque	Motor Min. 2 Nm @ nominal voltage Spring return Min. 2 Nm
Direction of rotation		Selected by mounting L / R	
Angle of rotation		Max. 95° \triangleleft (adjustable 37 ... 100% \triangleleft with built-in mechanical stop)	
Running time		Motor < 75 s (0 ... 2 Nm) Spring return < 25 s @ -20 ... 50°C / max. 60s @ -30°C	
Sound power level		Motor Max. 50 dB (A) Spring return Approx. 62 dB (A)	
Service life		Min. 60'000 operations	
Position indication		Mechanical	
Safety		Protection class	III Safety extra-low voltage
		Degree of protection	IP42 in any mounting position
		EMC	CE according to 89/336/EEC
	Low voltage directive	CE according to 73/23/EEC	
	Mode of operation	Type 1.AA.B (to EN 60730-1)	
	Overvoltage category	III	
	Control pollution degree	3	
	Ambient temperature range	-30 ... +50°C	
	Non-operating temperature	-40 ... +80°C	
	Ambient humidity range	95% r.H., non-condensating (EN 60730-1)	
Maintenance	Maintenance-free		
Dimensions / Weight	Dimensions	See «Dimensions» on page 2	
	Weight	Approx. 650 g	

Safety notes



- The spring return actuator is not allowed to be used outside the specified field of application, especially not in aircraft or any other form of air transport.
- Assembly must be carried out by trained personnel. Any legal regulations or regulations issued by authorities must be observed during assembly.
- The device may only be opened at the manufacturer's site. It does not contain any parts that can be replaced or repaired by the user.
- The cables must not be removed from the device.
- The device contains electrical and electronic components and is not allowed to be disposed of as household refuse. All locally valid regulations and requirements must be observed.

Product features

- Mode of operation** The actuator moves the damper to its normal working position while tensioning the return spring at the same time. If the power supply is interrupted, the energy stored in the spring moves the damper back to its safe position.
- Simple direct mounting** Simple direct mounting on the damper spindle with a universal spindle clamp. An antirotation device is supplied to prevent unwanted rotation of the whole unit.
- High functional reliability** The actuator is overload-proof, requires no limit switches and automatically stops when the end stop is reached.
- Flexible signalization** Flexible signalization with adjustable auxiliary switch (0 ... 100% ↵)

Electrical installation

Wiring diagram

Notes

- Connection via safety isolating transformer.
- Other actuators can be connected in parallel. Please note the performance data.

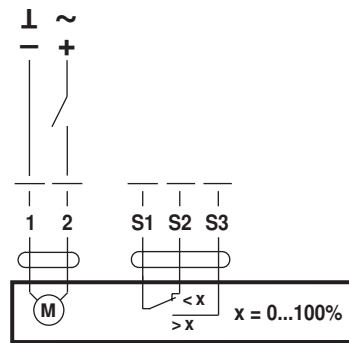

Dimensions [mm]

Dimensional drawings

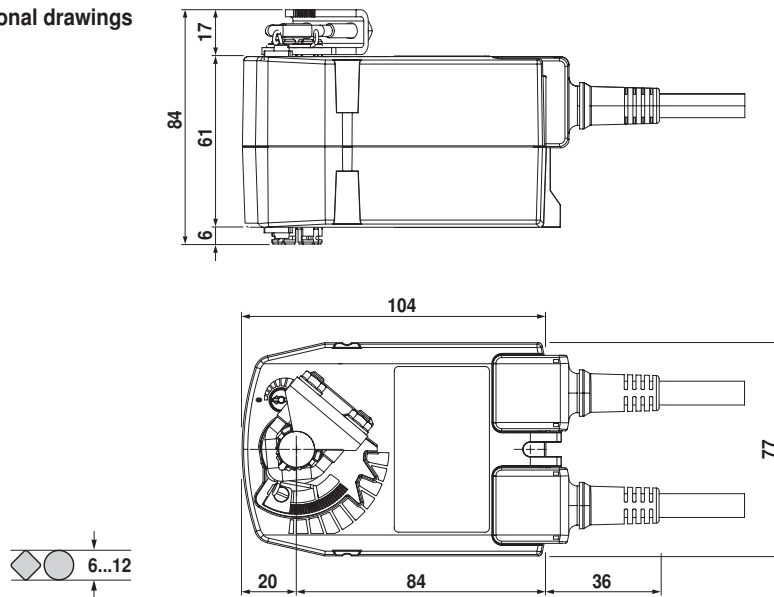

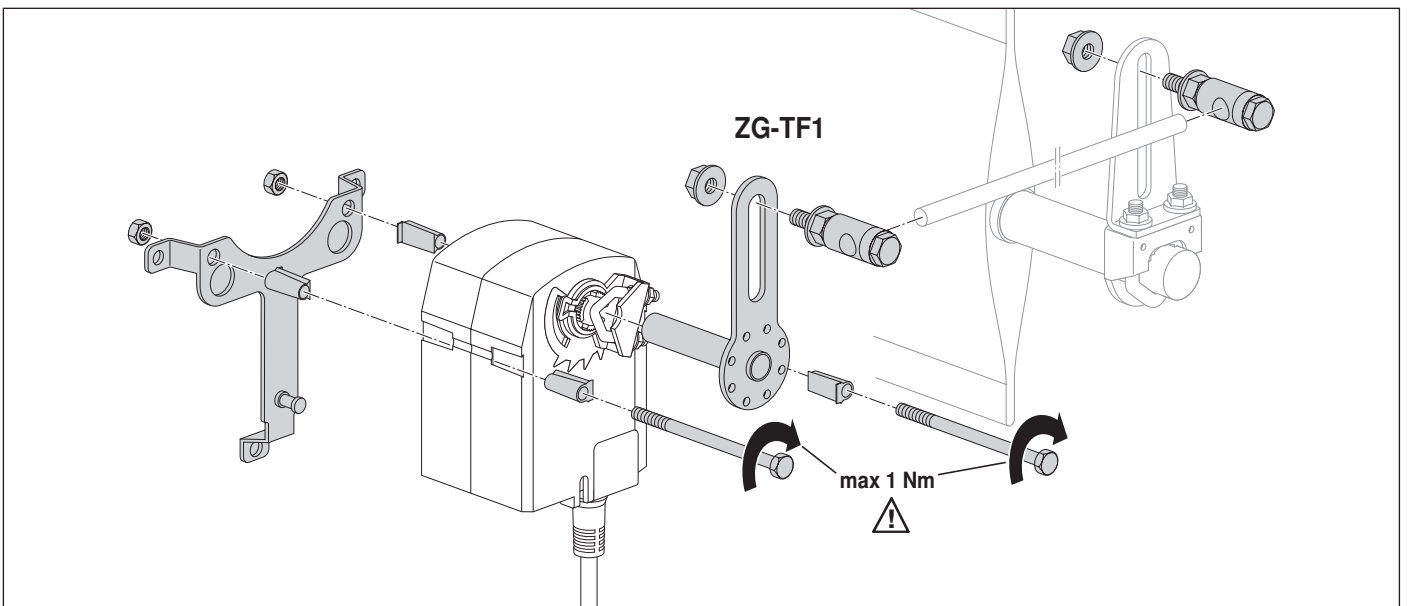
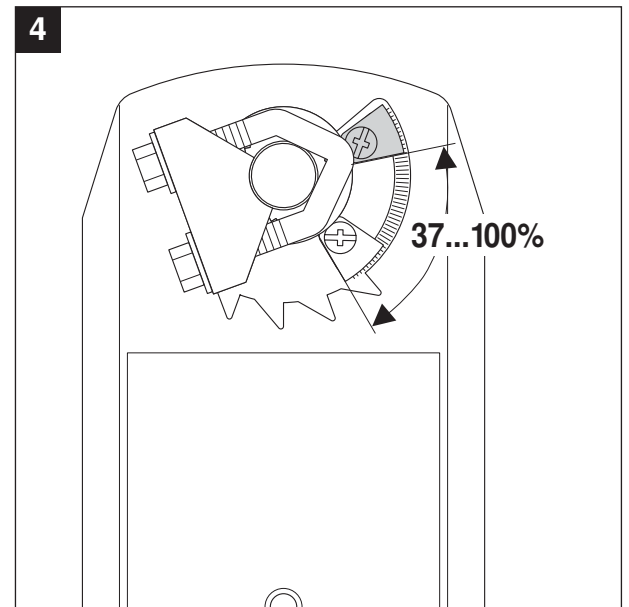
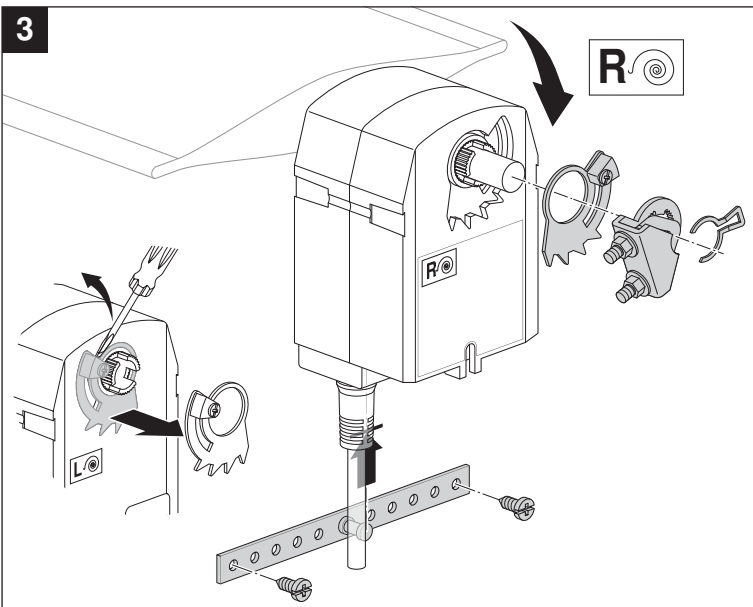
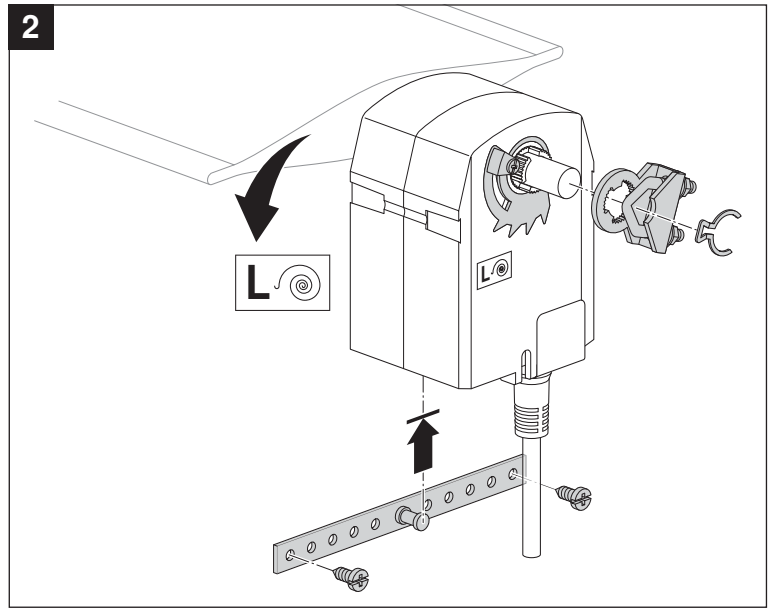
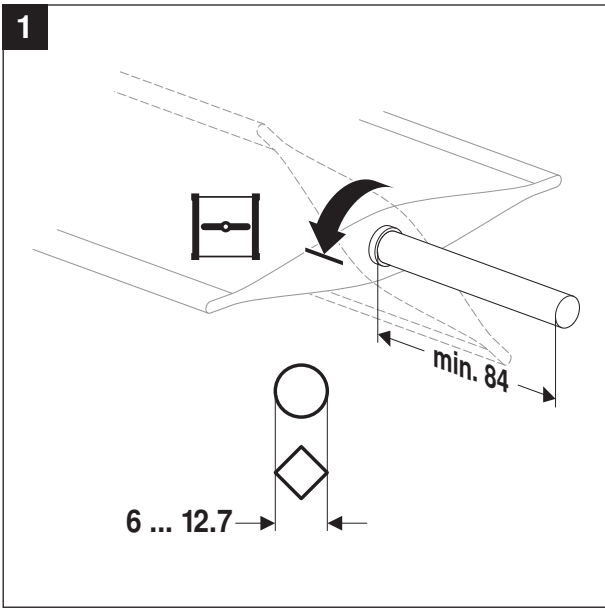

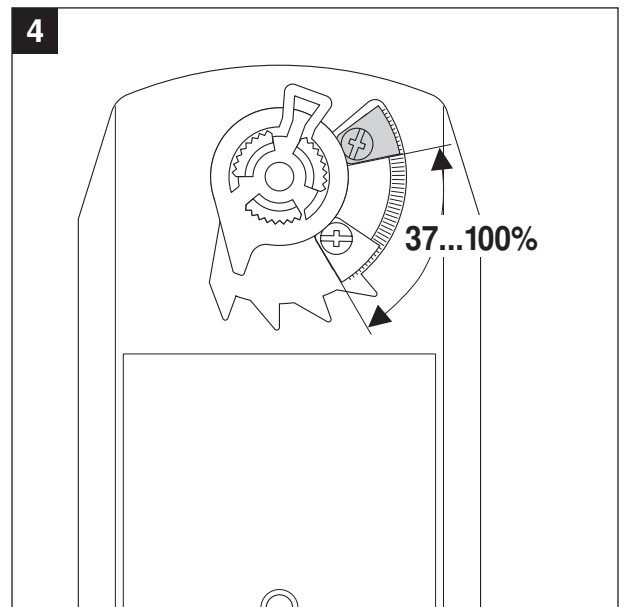
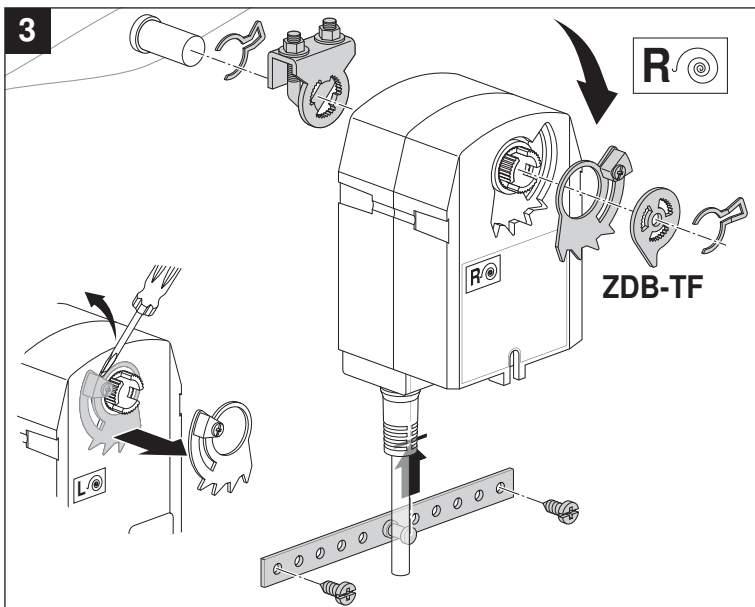
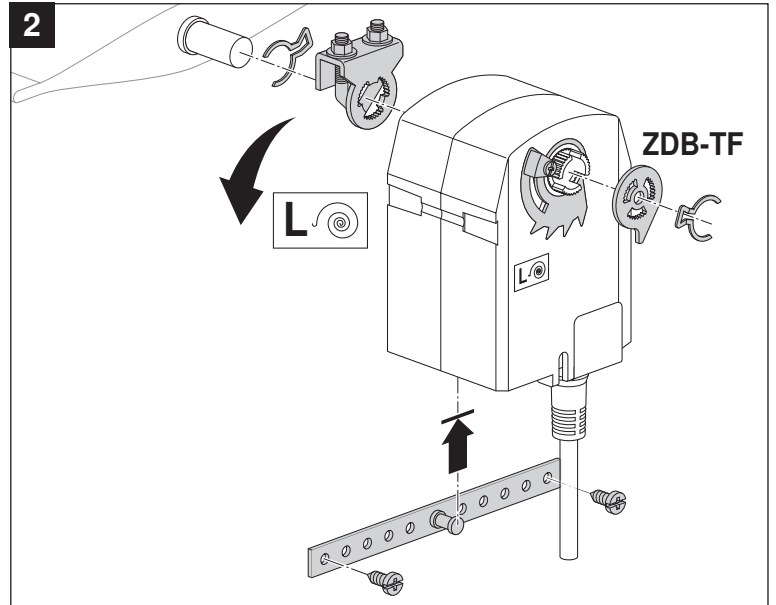
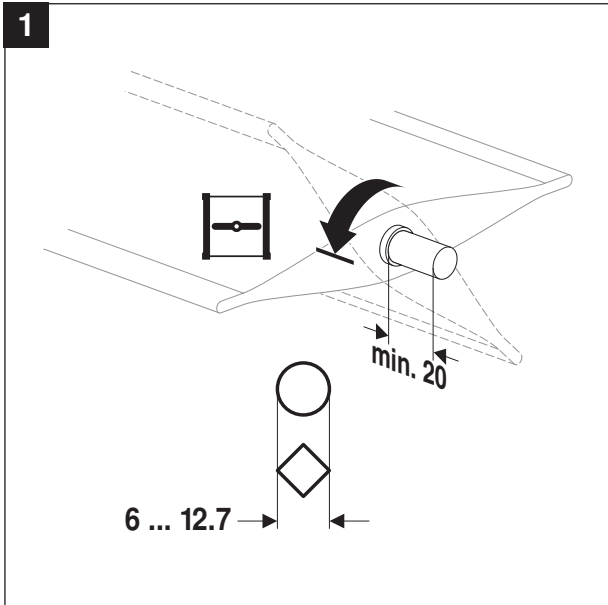

AC 230 V
AC 24 V / DC 24 V

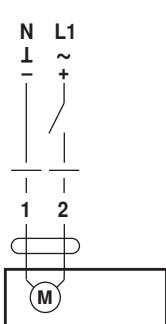

TF230 / TF24

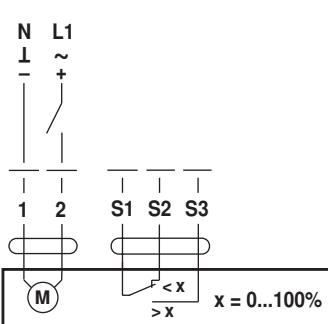

TF230-S / TF24-S

AC 24 V

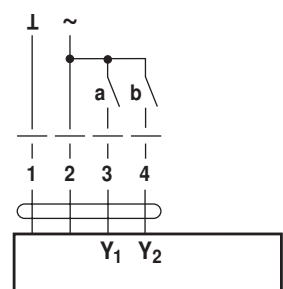

TF24-3

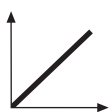

AC 24 V / DC 24 V

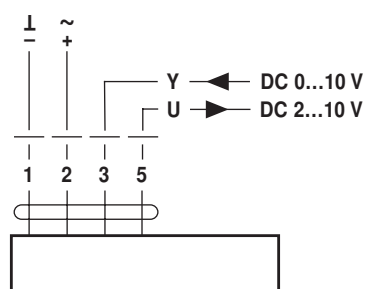

TF24-SR

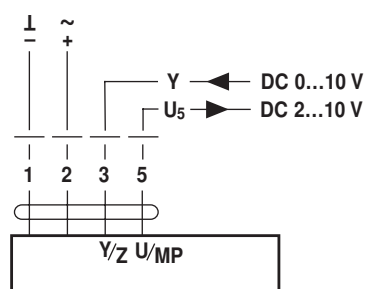

TF24-MFT