

Spring return actuator for the operation of air dampers that perform safety functions (e.g. frost and smoke protection, hygiene, etc.) for building services installations

- For dampers up to approx. 0.4 m<sup>2</sup>
- Torque 2 Nm
- Nominal voltage AC 100 ... 240 V
- Control: Open-close

**Technical data**

<b>Electrical data</b>	Nominal voltage	AC 100 ... 240 V, 50/60 Hz
	Nominal voltage range	AC 85 ... 265 V
	Power consumption	In operation 2.5 W @ nominal torque At rest 1.5 W For wire sizing 5 VA
	Connection Motor	Cable 1 m, 2 x 0.75 mm <sup>2</sup>
<b>Functional data</b>	Torque Motor	Min. 2 Nm @ nominal voltage
	Spring return	Min. 2 Nm
	Direction of rotation	Selected by mounting L / R
	Angle of rotation	Max. 95° ↺ (adjustable 37 ... 100% ↺ with built-in mechanical stop)
	Running time Motor	< 75 s (0 ... 2 Nm)
	Spring return	< 25 s @ -20 ... 50°C / max. 60s @ -30°C
	Sound power level Motor	Max. 50 dB (A)
	Spring return	Approx. 62 dB (A)
	Service life	Min. 60'000 operations
	Position indication	Mechanical
<b>Safety</b>	Protection class	II Totally insulated <input type="checkbox"/>
	Degree of protection	IP42 in any mounting position
	EMC	CE according to 89/336/EEC
	Low voltage directive	CE according to 73/23/EEC
	Mode of operation	Type 1.AA (to EN 60730-1)
	Overvoltage category	III
	Control pollution degree	3
	Ambient temperature range	-30 ... +50°C
	Non-operating temperature	-40 ... +80°C
	Ambient humidity range	95% r.H., non-condensating (EN 60730-1)
	Maintenance	Maintenance-free
<b>Dimensions / Weight</b>	Dimensions	See «Dimensions» on page 2
	Weight	Approx. 600 g

**Safety notes**

- The spring return actuator is not allowed to be used outside the specified field of application, especially not in aircraft or any other form of air transport.
- **Caution: Power supply voltage !**
- **Assembly must be carried out by trained personnel. Any legal regulations or regulations issued by authorities must be observed during assembly.**
- The device may only be opened at the manufacturer's site. It does not contain any parts that can be replaced or repaired by the user.
- The cable must not be removed from the device.
- The device contains electrical and electronic components and is not allowed to be disposed of as household refuse. All locally valid regulations and requirements must be observed.

## Product features

- Mode of operation** The actuator moves the damper to its normal working position while tensioning the return spring at the same time. If the power supply is interrupted, the energy stored in the spring moves the damper back to its safe position.
- Simple direct mounting** Simple direct mounting on the damper spindle with a universal spindle clamp. An antirotation device is supplied to prevent unwanted rotation of the whole unit.
- High functional reliability** The actuator is overload-proof, requires no limit switches and automatically stops when the end stop is reached.

## Electrical installation

### Wiring diagram

#### Notes

- Caution: Power supply voltage !
- Other actuators can be connected in parallel. Please note the performance data.

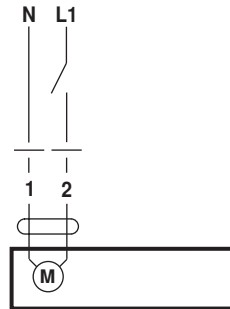

## Dimensions [mm]

### Dimensional drawings

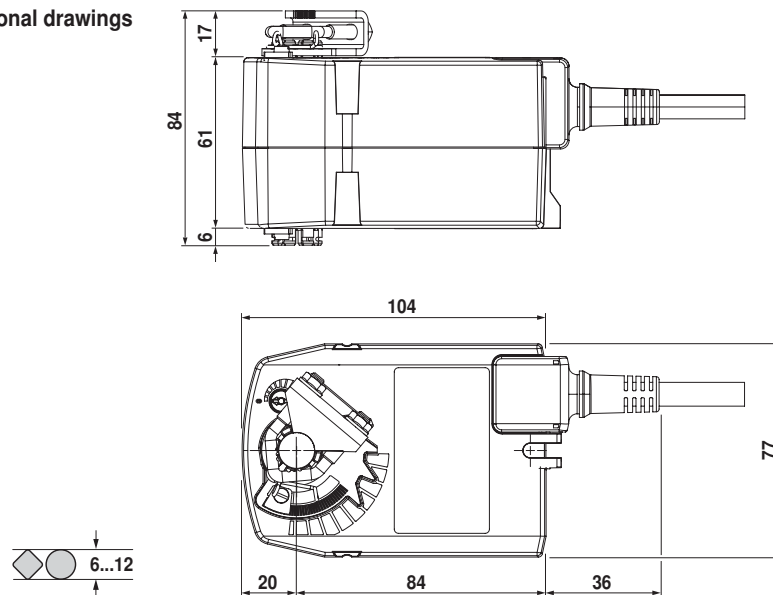

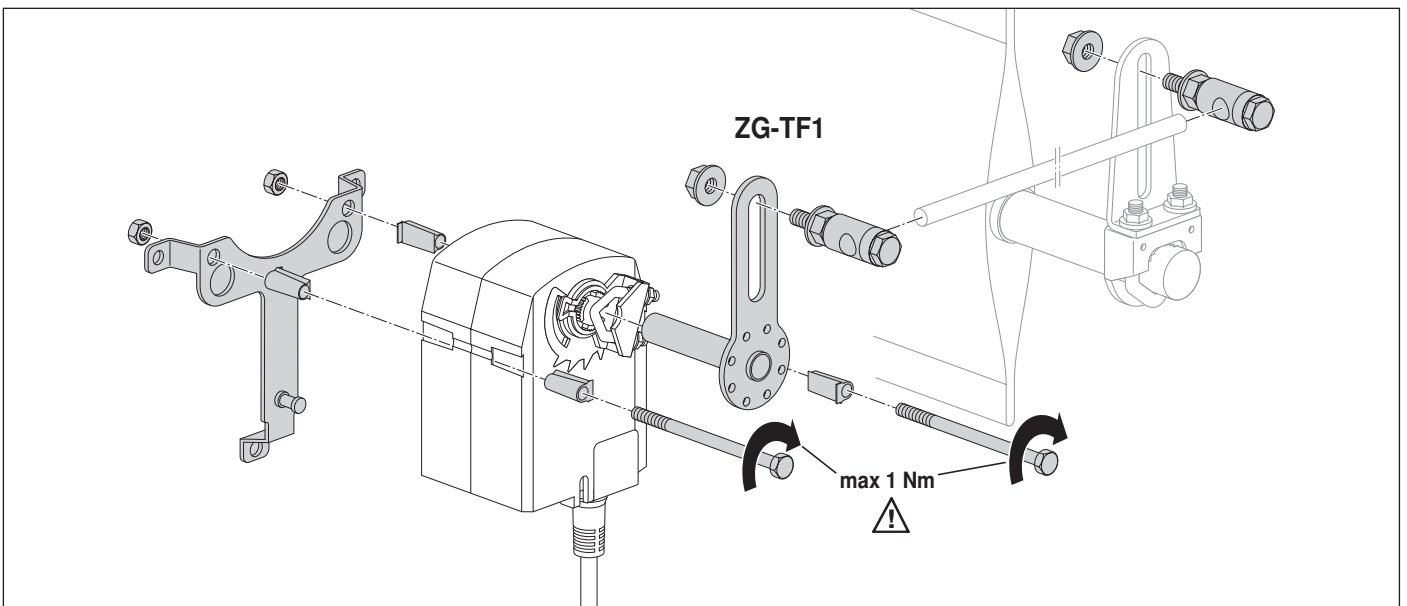
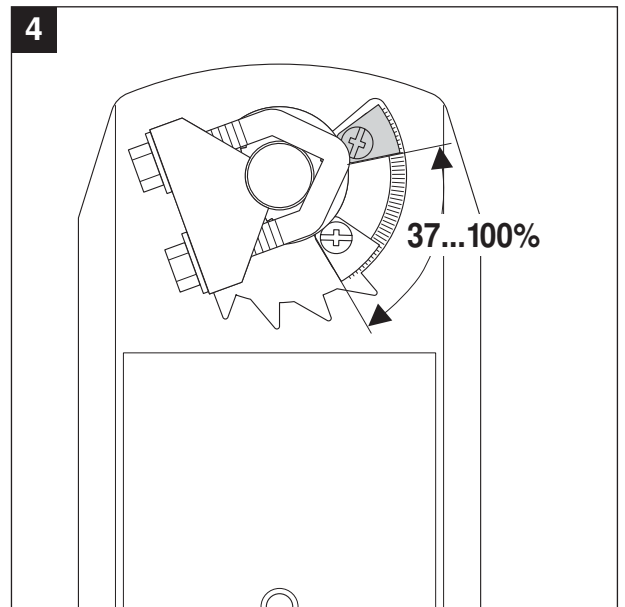
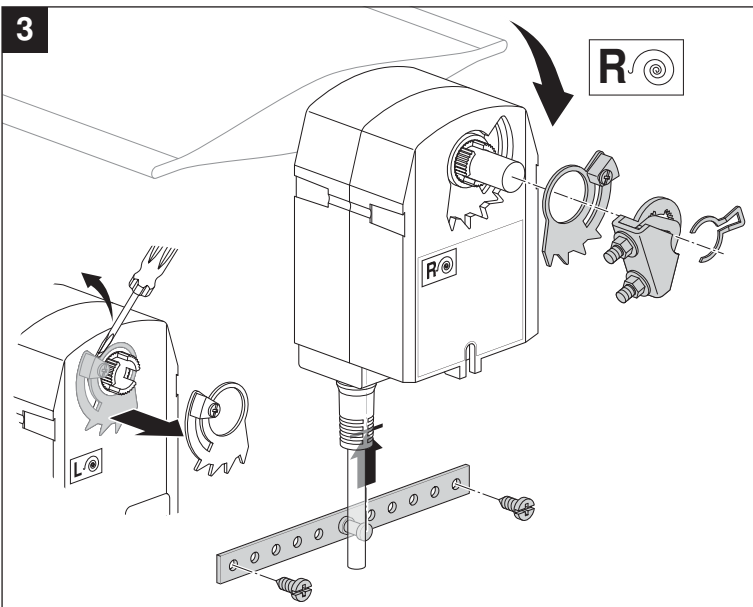
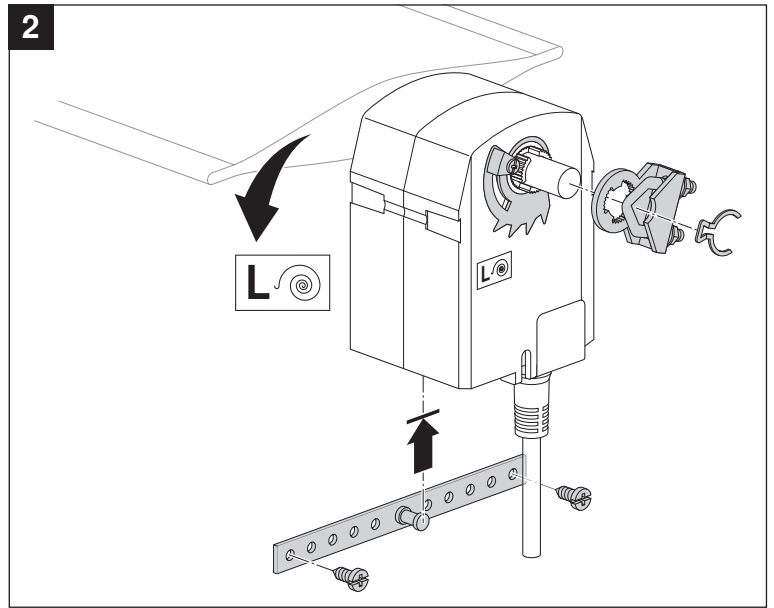
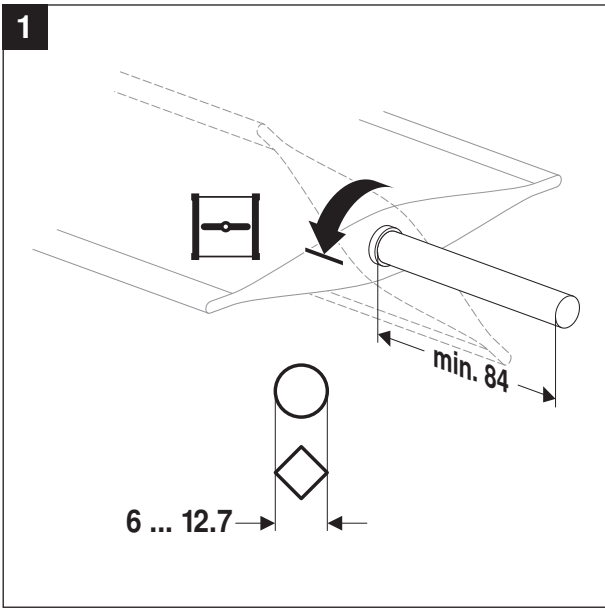

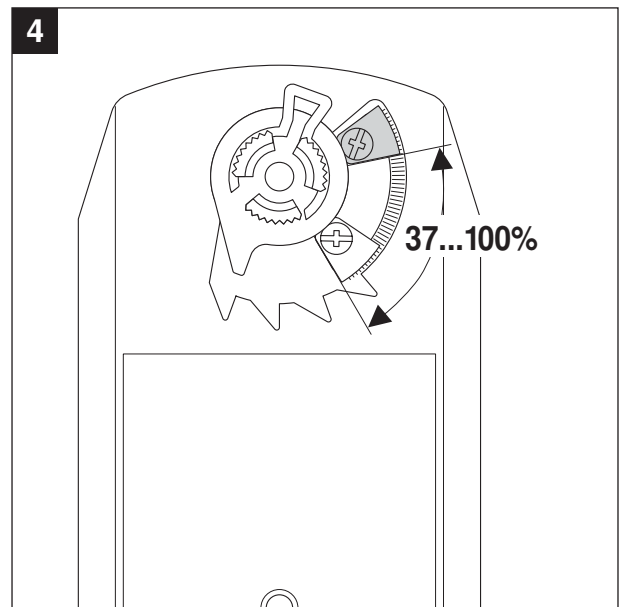
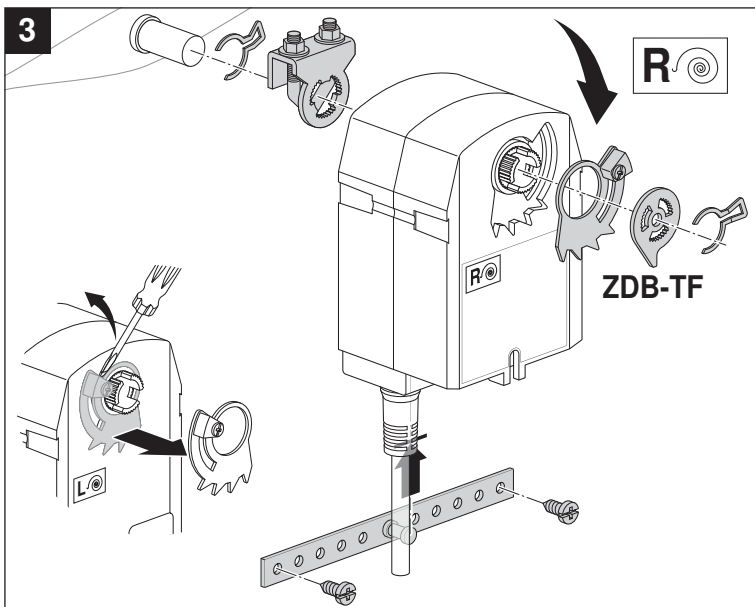
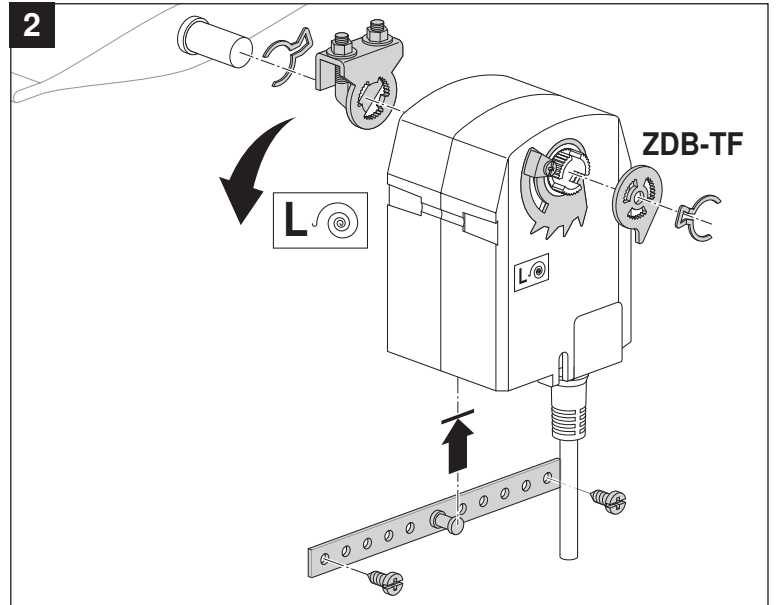
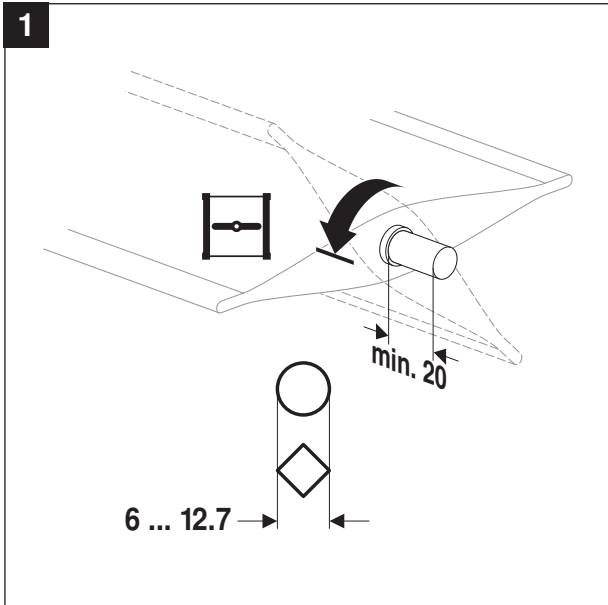

AC 230 V  
AC 24 V / DC 24 V

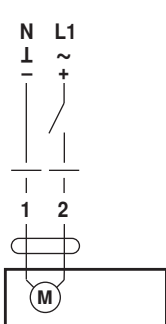

TF230 / TF24

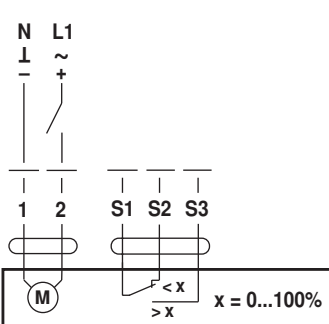

TF230-S / TF24-S

AC 24 V

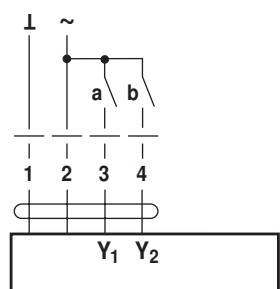

TF24-3

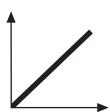

AC 24 V / DC 24 V

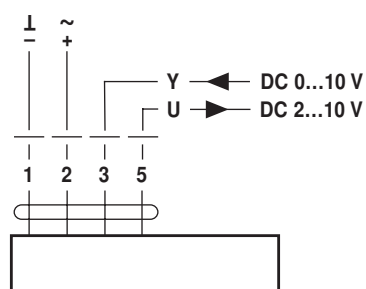

TF24-SR

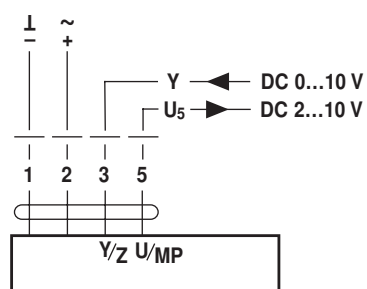

TF24-MFT