

Damper actuator for operating air control dampers in ventilation and air-conditioning systems for building services installations

- For air dampers up to approx. 0.4 m²
- Torque 2 Nm
- Nominal voltage AC 230 V
- Control: Open-close



Type overview

Type	Direction of rotation
CM230-1-L	counter-clockwise (ccw)
CM230-1-R	clockwise (cw)

Technical data

Electrical data	Nominal voltage	AC 230 V, 50 Hz	
	Nominal voltage range	AC 207 ... 253 V	
	Power consumption	In operation	1.5 W @ nominal torque
		At rest	1.5 W
	For wire sizing	8.5 VA	
	Connection	Cable 1 m, 3 x 0.75 mm ²	
Functional data	Torque (nominal torque)	Min. 2 Nm @ nominal voltage	
	Direction of rotation	See «Type overview»	
	Manual override	Gear disengagement with magnet	
	Angle of rotation	Without limit	Endless
		With limit	Fixed 315°↔ or 0 ... 287.5°↔ with mechanical end stops, can be adjusted in 2.5°↔ increments
	Running time	75 s / 90°↔	
	Sound power level	Max. 35 dB (A)	
Position indicator	Mechanical, pluggable (with integrated magnet for gear disengagement)		
Safety	Protection class	II totally insulated <input type="checkbox"/>	
	Degree of protection	IP54 in any mounting position NEMA2, UL Enclosure Type 2	
	EMC	CE according to 2004/108/EC	
	Low voltage directive	CE according to 2006/95/EC	
	Certification	cULus according to UL 60730-1A and UL 60730-2-14 and CAN/CSA E60730-1:02 Certified to IEC/EN 60730-1 and IEC/EN 60730-2-14	
	Mode of operation	Type 1 (EN 60730-1)	
	Rated impulse voltage	2.5 kV (EN 60730-1)	
	Control pollution degree	3 (EN 60730-1)	
	Ambient temperature	-30 ... +50 °C	
	Non-operating temperature	-40 ... +80 °C	
Ambient humidity	95% r.H., non-condensating (EN 60730-1)		
Maintenance	Maintenance-free		
Dimensions / Weight	Dimensions	See «Dimensions» on page 2	
	Weight	Approx. 220 g	

Safety notes



- The actuator is not allowed to be used outside the specified field of application, especially in aircraft or any other form of air transport.
- Caution: Power supply voltage !
- Assembly must be carried out by trained personnel. Any legal regulations or regulations issued by authorities must be observed during assembly.
- The device may only be opened at the manufacturer's site. It does not contain any parts that can be replaced or repaired by the user.

Safety notes

(Continue)

- When calculating the required torque, the specifications supplied by the damper manufacturers (cross section, design, installation site), and the air flow conditions must be observed.
- The device contains electrical and electronic components and is not allowed to be disposed of as household refuse. All locally valid regulations and requirements must be observed.

Product features

- Simple direct mounting** Simple direct mounting on the damper spindle with a universal spindle clamp (\varnothing 6 ... 12.7 mm). The actuator is then secured with the anti-rotation strap supplied, to prevent it from rotating.
- Manual override** Manual override with magnet possible (the gear is disengaged as long as the magnet adheres to the symbol ©). The magnet for gear disengagement is integrated in the position indicator.
- Adjustable angle of rotation** Adjustable angle of rotation with mechanical end stops.
- High functional reliability** The actuator is overload-proof, requires no limit switches and automatically stops when the end stop is reached.

Electrical installation

Wiring diagram

Notes

- Caution: Power supply voltage !
- Other actuators CM230-1-.. can be connected in parallel. Please note the performance data.

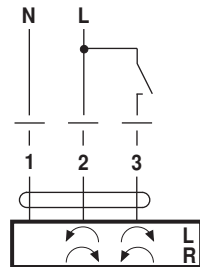

Dimensions [mm]

Dimensional drawings

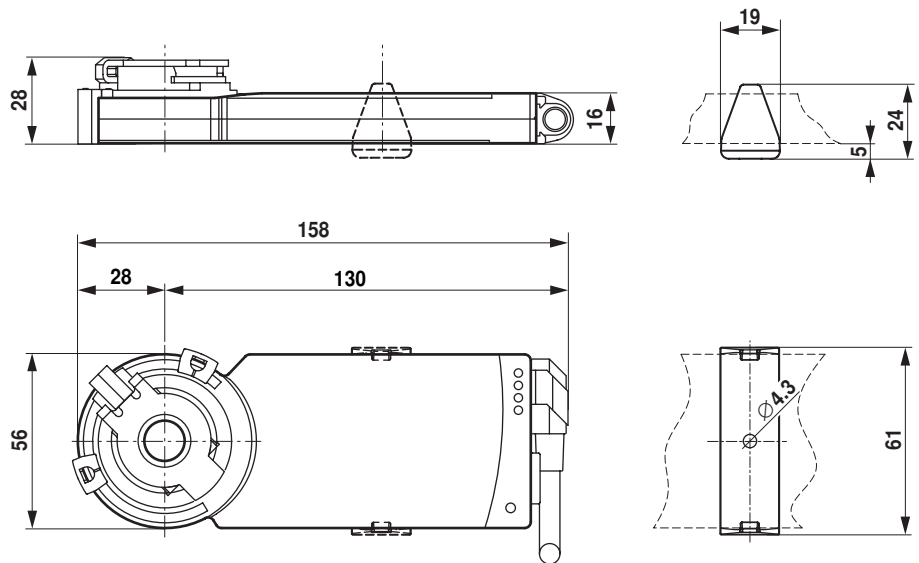

Damper spindle	Length	\varnothing
	≥ 32	6 ... 12.7

70670-00002.E

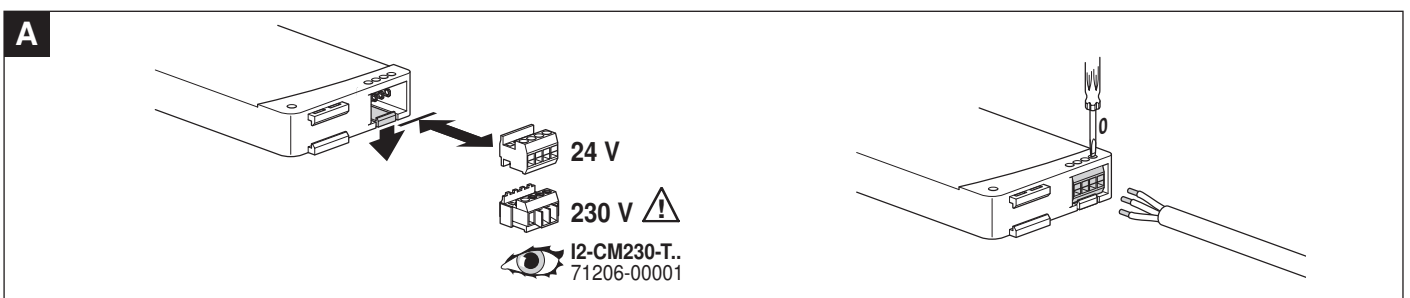
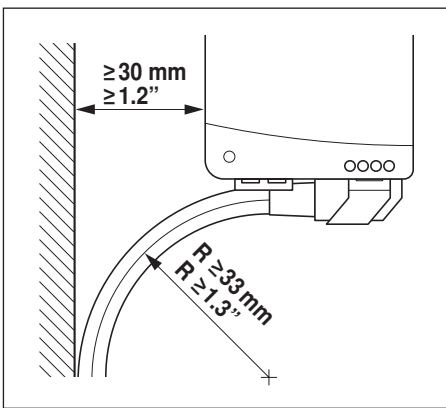
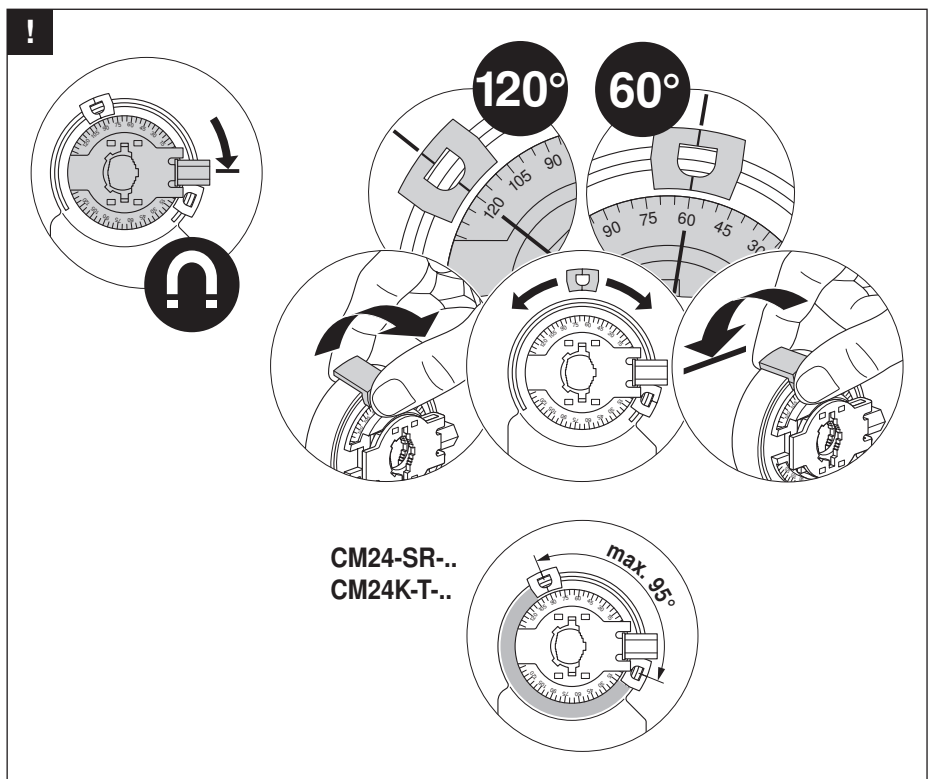
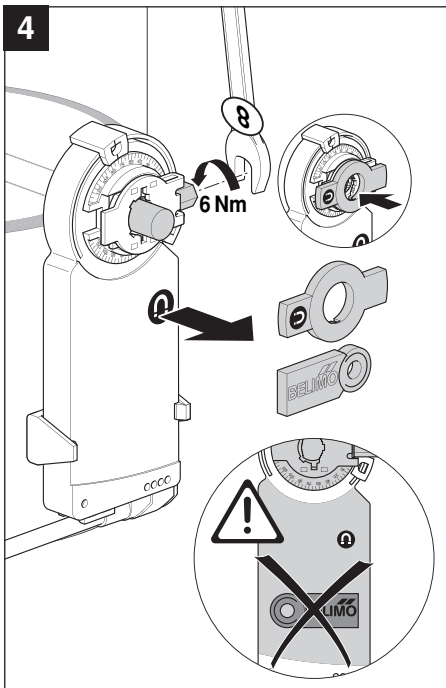
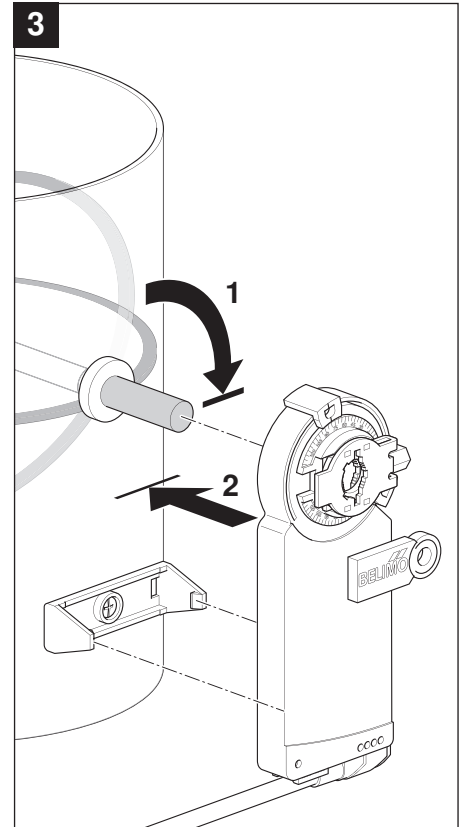
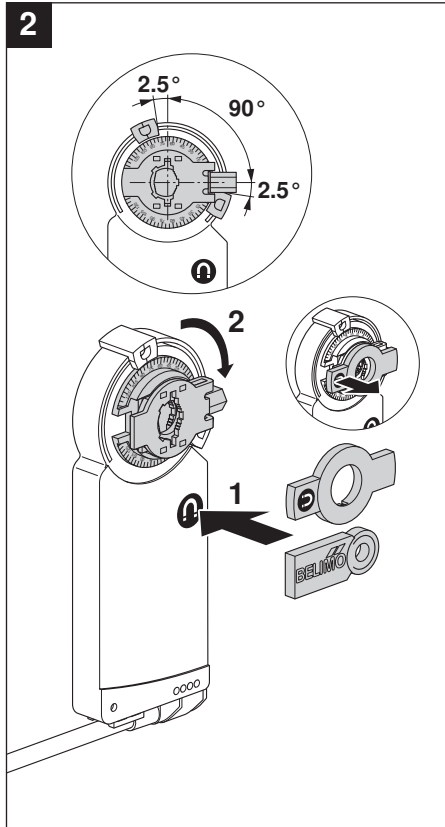
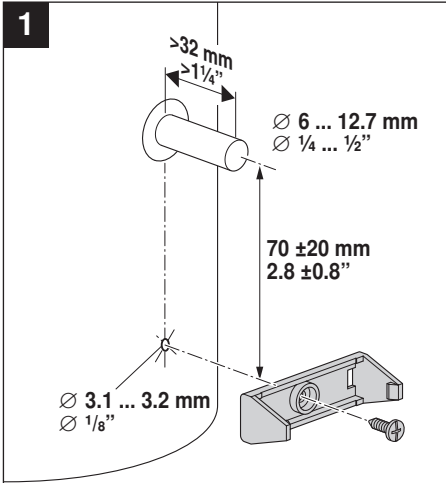

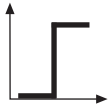

AC 24 V / DC 24 V

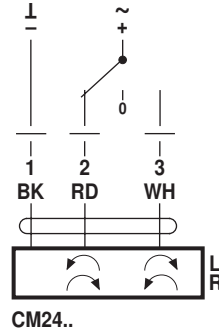
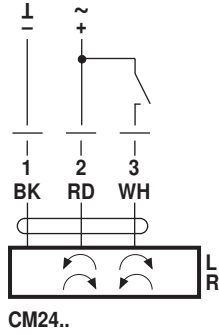

DC 24 V
(SKM230..)

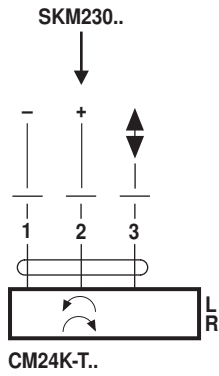

AC 100 ... 240 V ⚠

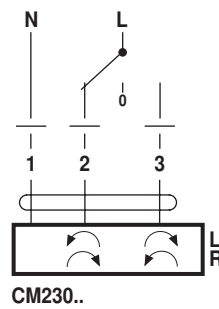
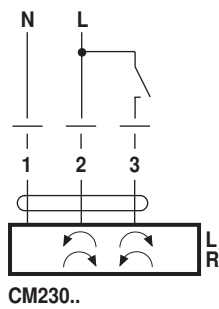

AC 230 V ⚠

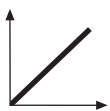
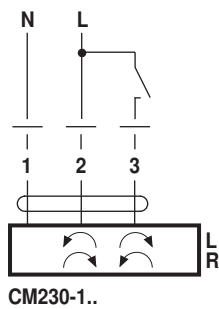

AC 24 V / DC 24 V

