

RTX 09/16

Roof-top
Air/Air for external installation
with plug fans and scroll compressors
Cooling capacities 51÷132kW
Heating capacities 50÷134kW

R410A



- **HANDLING SECTION WITH PLUG FAN COUPLED WITH BRUSHLESS EC MOTORS**
- **THERMODYNAMIC HEAT RECOVERY**
- **FREE-COOLING/ENTHALPIC FREE-COOLING OPTION**
- **FOR MEDIUM CROWDING APPLICATIONS**

Features

- Independent Roof-top type air cooled air conditioner, for treatment, filtration and renewal of the air, based on the chosen configuration. RTX units are designed for medium crowding applications, like shopping malls, shops, offices, production areas being designed for operation with 30% external and expelled air (version MB3).

The unit based on the version and selected accessories allows the management of the free-cooling operation, and can be equipped with a recuperator to recover the energy contained in the exhaust air allowing higher performances and efficiencies.

Versions

- RTX_F cooling only version
- RTX_H heat pump version

Configurations

- MB2** with mixing chambers and two dampers
 - MB3** with mixing chamber with three dampers return fan and heat recovery from expelled air
 - MB1** recirculation only
- Each of the different configuration can be further customized with a wide choice of accessories.

- 1 cooling circuit
- High efficiency scroll compressors (tandem UNEVEN) and low power consumption
- Internal and external direct expansion finned heat exchangers
- Supply and return fans (if present), of plug fan type (EC). The impellers are so oriented to ensure that the air flow passes through the internal com-

ponents, with the minimum noise.

- Group of axial fans for extremely silent operation placed on the condensing section with standard condensation electronic control.
- G4 air filter on the flow of outside air and on the recovery, are installed upstream of the components, to ensure low pressure drops.
- Microprocessor control can handle the different modes of operation ensuring maximum energy savings in any conditions. Interfaces for connections to BMS and optional remote control available.

Accessories and fittings

- **SSV:** Supervision system.
- **RS:** Serial card BMS RS485
- **LW:** Interface card LonWorks
- **BIP:** Interface card Ethernet-pCOWeb (BACNET IP)
- **BAC:** Interface card BACnet MS/TP pConet
- **FCT:** Temperature Free-cooling
- **FTH:** Enthalpic Free-cooling
- **PSTEP:** Adjusting constant flow, step flow in function of the modulation of the cooling circuit.
- **FT7:** Pocket filters F7 efficiency placed on the flow of supply air
- **FT9:** Pocket filters F9 efficiency placed on the flow of supply air.
- **H10:** Electronic filters placed on the flow of supply air.
- **PSF:** Differential pressure switch signaling fouled filters of recovery, renewal and discharge (if present)
- **PSF2:** Differential pressure switch signaling fouled filters, renewal and supply.
- **Gx:** heating module with gas burner
- **BW:** 2-rows-heating coil with hot water
- **BWV2V:** 2-rows-heating coil with hot water, with 2-way modulating valve
- **BWV3V:** 2-rows heating coil with hot water, with

- 3-way modulating valve
- **BE:** Electric heating coil 2 stages (**not available with hot air generator**)
- **BEM:** Modulating electric heating coil (**not available with hot air generator**)
- **BPGC:** After heating coil with hot gas
- **DCPR:** AC fans with pressure switch device of speed control function of the pressure of condensation and evaporation.
- **AXEC:** Axial fans with EC motors with speed control function according to the pressure of condensation and evaporation
- **MAN:** High and low pressure gauges
- **U:** Installed steam ramp
- **UP:** Immersed electrode producer standard supplied and installed steam ramp
- **CUR:** Humidification control (humidity probe in recovery, limit humidity probe in supply, contact ON/OFF and modulating analog output)
- **DP:** Dehumidification control (humidity probe in recovery) and of after-heating (if present)
- **SCO2:** Probe CO₂ (**not available on MB1 FITTINGS**)
- **SVOC:** Probe VOC (**not available on MB1 FITTINGS**)
- **STA:** Room temperature probe

- **SUA:** Room humidity probe
- **RF:** Smoke detector
- **RFC:** Smoke detector and recirculation damper closure management and external air intake
- **PR1:** Remote control panel
- **SCM:** Modulating servo-controls (standard supplied on the MB3 equipment or if present FCT/FCH)
- **SCMRM:** Modulating Servo-control with spring return
- **CA:** Waterproof headphones on external air intake
- **CF:** Flue pipe (only on version with gas burner module)
- **GP:** Protection grille for external coils
- **VT:** antivibration mounts
- **MSSM:** Delivery silencers forms (only for rear air delivery)
- **MSSR:** Recovery silencers forms (only for rear air delivery)

NOTE for more details on accessories and equipment, please refer to the technical handbook

Features and technological advantages

RTX units have been designed with the aim of reducing energy consumption that dictated the result of technological choices present on the unit that we briefly present.

- HIGH EFFICIENCY VENTILATION**
Ventilation is one of the major factors of power consumption; for this reason particular attention has been given to the study and the construction of the ventilation system.

They have been used in both supply and recovery (if present), **fans or plug fans with EC brushless motors** which enables high performances, and low power consumption, also compared to conventional centrifugal fans, they have no belts or pulleys allowing easy flow regulation, compactness, versatility and ease of maintenance.

A particular adaptive logic allows to adjust the air flow to the actual demand of the system with more consequent advantages in terms of reduction of consumption.

Axial fans for the external section of the unit are of helical type; the electronic control of condensation is standard and it regulates the fan speed according to the load required allowing a noise reduction.

As an option, the motors can be electronically controlled (EC) for the reduction in consumption of the condenser section.

- MAXIMUM SEASONAL EFFICIENCY**
 To improve the efficiency of the cooling circuit, we have used scroll tandem compressors with different power between them (compressors UNEVEN except for sizes 09 and 14). This feature allows a reduction of consumptions and a better adaptability to the demands of the system., especially in the operation at partial loads, ensuring higher seasonal efficiency.
- AIR QUALITY IN THE ROOM**
 Particular attention has been given to the quality of air naturally in the room, entrusted to the standard filters with G4 efficiency on the flow of outside air, also available on the recovery (optional) for process applications. They are also available as (optional) compact filters F7 and F9 or electronic H10 flow of fresh air.
- ACTIVE THERMODYNAMIC RECOVERY**
 In the "MB3" setting there is also a thermodynamic recovery for the recovery of energy contained in expelled air, in such a way that the expelled air flow invests the external finned heat exchanger, allowing higher performances and efficiencies.

Of course all these technological advantages are controlled by a temperature control of the latest generation, able to handle the different modes of operation; ensuring maximum energy savings in all operating conditions by means of special software.

Basic configuration "MB2"

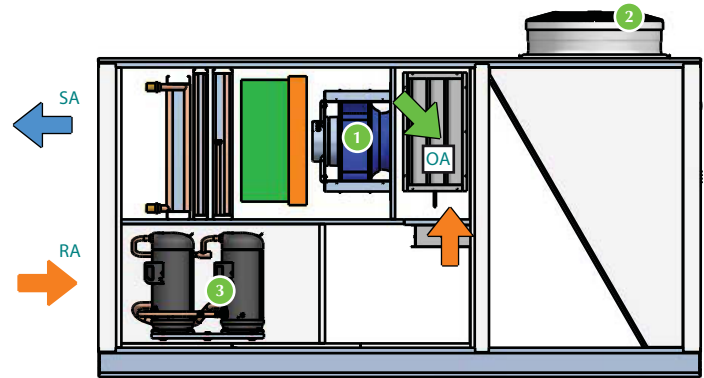

- 1 Plug fan supply only
 - 2 Axial fans
 - 3 Tandem scroll compressors
- SA air supply
 RA extracted air
 OA external air

1

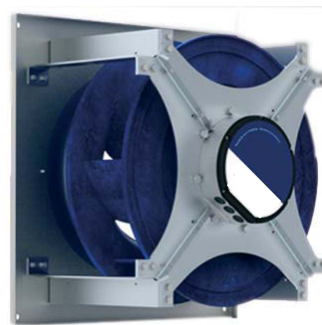

3



Configuration with thermodynamic recovery "MB3"

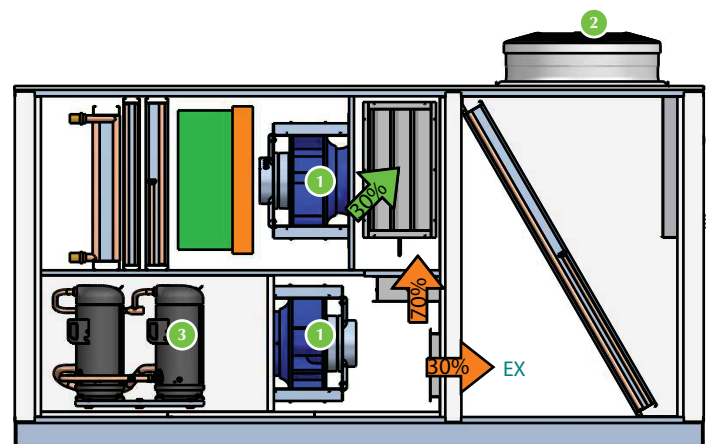

- 1 Plugfan supply and recovery
 - 2 Axial fans
 - 3 Tandem scroll compressor
 - 4 Thermodynamic recovery
- EX exhaust air

Technical data

Mod. RTX cooling only (standard version MB2)			09	10	11	12	13	14	15	16
Cooling capacity	(1)	kW	51,6	62,0	70,4	84,1	97,3	107,6	118,6	129,9
Sensitive cooling capacity		kW	38,6	44,4	49,7	60,6	68,3	78,5	85,2	91,2
Compressor input power		kW	11,2	14,9	17,4	18,4	22,2	24,5	28,9	34,3
EER		W/W	4,6	4,2	4,0	4,6	4,4	4,4	4,1	3,8
Cooling capacity	(2)	kW	53,2	63,8	72,5	86,6	100,1	110,6	122,0	133,6
Sensitive cooling capacity		kW	37,3	42,9	48,1	58,6	65,9	75,9	81,5	88,6
Compressor input power		kW	11,3	15,0	17,5	18,5	22,4	24,8	29,2	34,6
EER		W/W	4,7	4,3	4,1	4,7	4,5	4,5	4,2	3,9

Mod. RTX cooling only (MB3 dynamic version)			09	10	11	12	13	14	15	16
Cooling capacity	(1)	kW	52,2	62,6	71,3	85	98,4	108,9	120,2	131,9
Sensitive cooling capacity		kW	38,9	44,4	50,1	61,2	69,1	78,8	85,7	92
Compressor input power		kW	11	14,5	16,9	18	21,6	23,9	28,1	33,2
EER		W/W	4,80	4,40	4,30	4,80	4,60	4,60	4,40	4,00
Cooling capacity	(2)	kW	53,8	64,5	73,5	87,6	101,3	112	123,7	135,7
Sensitive cooling capacity		kW	37,4	43	48,4	59,2	66,7	76,1	82,7	88,6
Compressor input power		kW	11,1	14,6	17	18,1	21,8	24,1	28,4	33,5
EER		W/W	4,80	4,40	4,30	4,80	4,60	4,60	4,40	4,00

Cooling

(1) Internal temperature 27°C b.s., 19°C b.u.; External temperature 35°C b.s., 24°C b.u. (EN14511); Operating with 30% external and expelled air
 (2) Internal temperature 27°C b.s., 19°C b.u.; External temperature 35°C b.s., 26°C b.u.; Operating with 30% external and expelled air

RTX Heat pump version (standard version MB2)			09	10	11	12	13	14	15	16
Cooling capacity	(1)	kW	51,6	62,0	70,4	84,1	97,3	107,6	118,6	129,9
Sensitive cooling capacity		kW	38,6	44,4	49,7	60,6	68,3	78,5	85,2	91,2
Compressor input power		kW	11,2	14,9	17,4	18,4	22,2	24,5	28,9	34,3
EER		W/W	4,6	4,2	4,0	4,6	4,4	4,4	4,1	3,8
Cooling capacity	(2)	kW	53,2	63,8	72,5	86,6	100,1	110,6	122,0	133,6
Sensitive cooling capacity		kW	37,3	42,9	48,1	58,6	65,9	75,9	81,5	88,6
Compressor input power		kW	11,3	15,0	17,5	18,5	22,4	24,8	29,2	34,6
EER		W/W	4,7	4,3	4,1	4,7	4,5	4,5	4,2	3,9
Heating power	(3)	kW	50,0	61,4	69,9	81,7	94,7	103,2	114,7	127,5
Compressor input power		kW	8,7	12	13,6	15	17,3	18,5	21,4	24,9
COP		W/W	5,70	5,10	5,10	5,40	5,50	5,60	5,40	5,10

Mod. RTX Heat pump (MB3 dynamic version)			09	10	11	12	13	14	15	16
Cooling capacity	(1)	kW	52,2	62,6	71,3	85	98,4	108,9	120,2	131,9
Sensitive cooling capacity		kW	38,9	44,4	50,1	61,2	69,1	78,8	85,7	92
Compressor input power		kW	11	14,5	16,9	18	21,6	23,9	28,1	33,2
EER		W/W	4,80	4,40	4,30	4,80	4,60	4,60	4,40	4,00
Cooling capacity	(2)	kW	53,8	64,5	73,5	87,6	101,3	112	123,7	135,7
Sensitive cooling capacity		kW	37,4	43	48,4	59,2	66,7	76,1	82,7	88,6
Compressor input power		kW	11,1	14,6	17	18,1	21,8	24,1	28,4	33,5
EER		W/W	4,80	4,40	4,30	4,80	4,60	4,60	4,40	4,00
Heating power	(3)	kW	51,5	63,5	73,0	84,6	98,5	107,6	120,1	133,9
Compressor input power		kW	8,8	12,2	13,8	15,2	17,7	18,8	21,9	25,6
COP		W/W	5,80	5,20	5,30	5,60	5,60	5,70	5,50	5,20

Cooling

(1) Internal temperature 27°C b.s., 19°C b.u.; External temperature 35°C b.s., 24°C b.u. (EN14511); Operating with 30% external and expelled air
 (2) Internal temperature 27°C b.s., 19°C b.u.; External temperature 35°C b.s., 26°C b.u.; Operating with 30% external and expelled air

Heating

(3) Internal temperature 20°C b.s., 15°C b.u.; External temperature 7°C b.s. 6°C b.u. (EN14511); Operating with 30% external and expelled air

Technical data

GENERAL DATA			09	10	11	12	13	14	15	16
Compressors										
Compressors	type		scroll	scroll	scroll	scroll	scroll	scroll	scroll	scroll
	n°		2	2	2	2	2	2	2	2
Circuits	n°		1	1	1	1	1	1	1	1
Capacity steps	(3)	%	2	3	3	3	3	2	3	3
Refrigerant gas		type	R410A	R410A	R410A	R410A	R410A	R410A	R410A	R410A
Fans										
External fans	type		axial AC	axial AC	axial AC	axial AC	axial AC	axial AC	axial AC	axial AC
	n°		2	2	2	2	2	2	2	2
Fans of internal flows	type		RAD EC	RAD EC	RAD EC	RAD EC	RAD EC	RAD EC	RAD EC	RAD EC
	n°		1	1	1	1	2	2	2	2
	Ø mm		500	560	630	630	500	560	560	560
Fans of internal recovery	(4) MB3 type		RAD EC	RAD EC	RAD EC	RAD EC	RAD EC	RAD EC	RAD EC	RAD EC
	(4) MB3 n°		1	1	1	1	2	2	2	2
	(4) MB3 Ø mm		500	500	500	450	450	500	500	500
Air flow of inside fan	nom/max	m³/h	9.500	11.000	13.000	15.500	18.000	20.000	22.000	24.000
	min	m³/h	6.650	7.700	9.100	10.850	12.600	14.000	15.400	16.800
Available static pressure (flow)	(5)	Pa	644	517	566	434	672	608	512	763
Available static pressure (recovery)	(5)	Pa	297	304	314	302	311	313	320	328
Sound data										
Sound pressure		dB(A)	70	69	72	75	76	76	78	80
Sound power		dB(A)	78	77	80	83	84	84	86	88
Power supply		V/ph/Hz	400V/3/50Hz							

(3) Sizes 09-14 don't have UNEVEN compressors

(4) Not present in configurations MB2 and MB1

(5) At the nominal/maximum capacity, G4 filter medium fouling

Sound pressure

Sound pressure measured in free field (1m, Q=2) away from the outer surface of the ducted unit, Available static pressure 300Pa at nominal flow (in accordance with the UNI EN ISO 3744).

Note: For more informations please refer to the technical documentation available on the website [Aermec](http://www.aermec.com)

Dimensional data(mm)

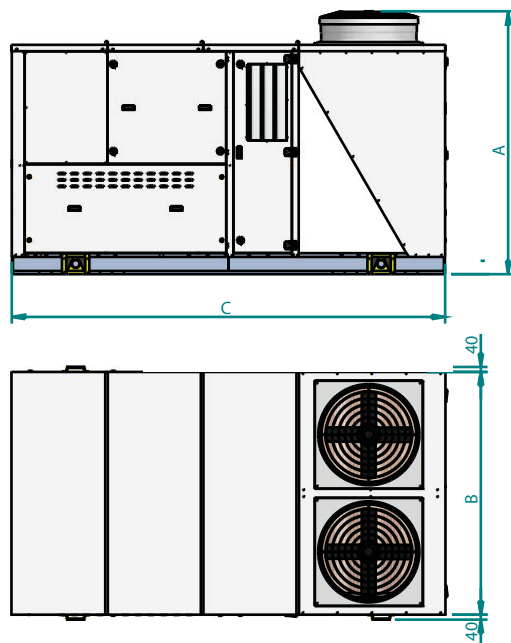

Mod. NRL	Vers.	09	10	11	12	13	14	15	16
Height (mm)	A	2061	2061	2061	2373	2373	2440	2440	2440
Width (mm)	B	1900	1900	1900	2100	2100	2200	2200	2200
Depth (mm)	C	3400	3400	3400	3400	3400	4000	4000	4000
Empty weight (kg)	MB2	c.s.	c.s.	c.s.	c.s.	c.s.	c.s.	c.s.	c.s.
	MB3	c.s.	c.s.	c.s.	c.s.	c.s.	c.s.	c.s.	c.s.

c.s. Please contact head office

Aermec reserves the right to make all modification deemed necessary for improving the product at any time with any modification of technical data.

Aermec S.p.A.
Via Roma, 996 - 37040 Bevilacqua (VR) - Italia
Tel. 0442633111 - Telefax 044293730