

RDA_V

Raccordo Dritto di Aspirazione con flangia rettangolare
Straight Intake Fitting with rectangular flange
Raccord Droit d'Aspiration avec bride rectangulaire
Gerades Ansauganschlusstück mit rechteckigem Flansch
Racor derecho de aspiración con brida rectangular

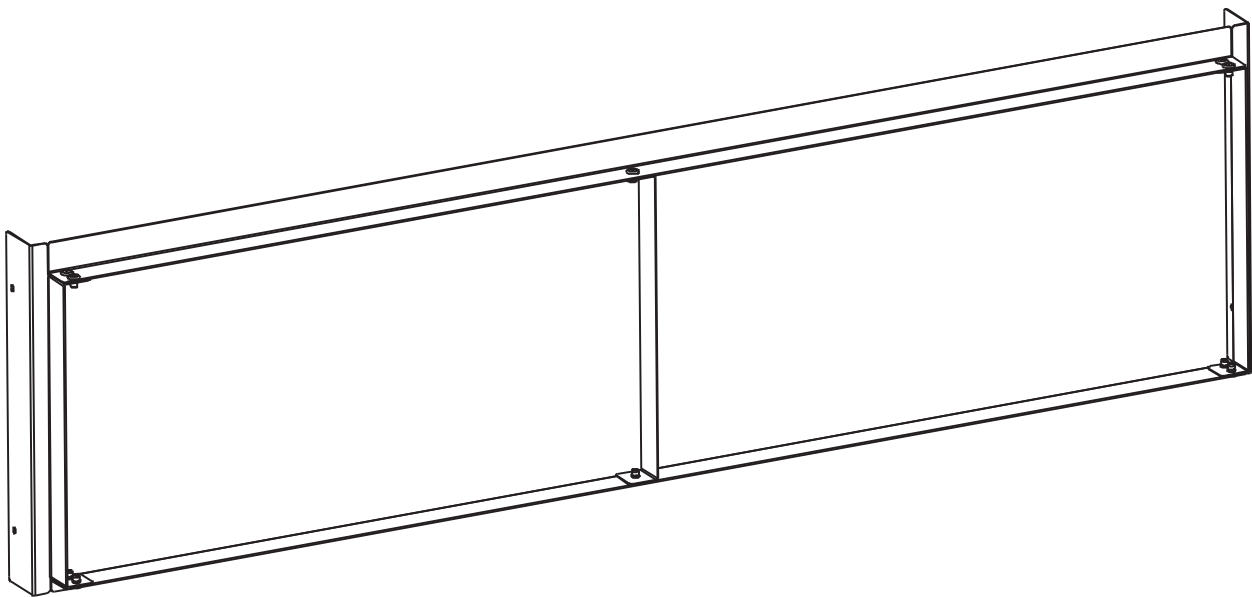

- IT pag. 2
- GB pag. 4
- FR pag. 6
- DE pag. 8
- ES pag. 10



DESCRIPTION: RDA_V is a straight intake fitting with rectangular flange. This accessory, in galvanised sheet steel, allows to connect a channel with rectangular section to the intake vent of the VED unit.

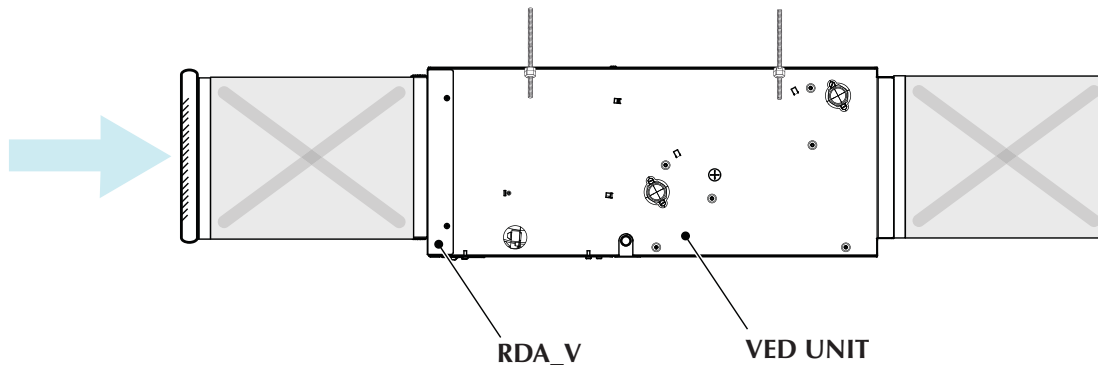

COMPONENTS OF THE KIT:

- Straight Intake Fitting with rectangular flange
- N°4 self-threading screws
- Gasket with adhesive side

TABLEAU DE TAILLES COMPATIBILITÉ:

	SIZE VED															
	430	432	440	441	530	532	540	541	630	632	640	641	730	732	740	741
<i>RDA450V</i>	✓	✓	✓	✓	✓	✓	✓	✓								
<i>RDA670V</i>									✓	✓	✓	✓	✓	✓	✓	✓

DIMENSIONAL DATA:

RDA450V

RDA670V

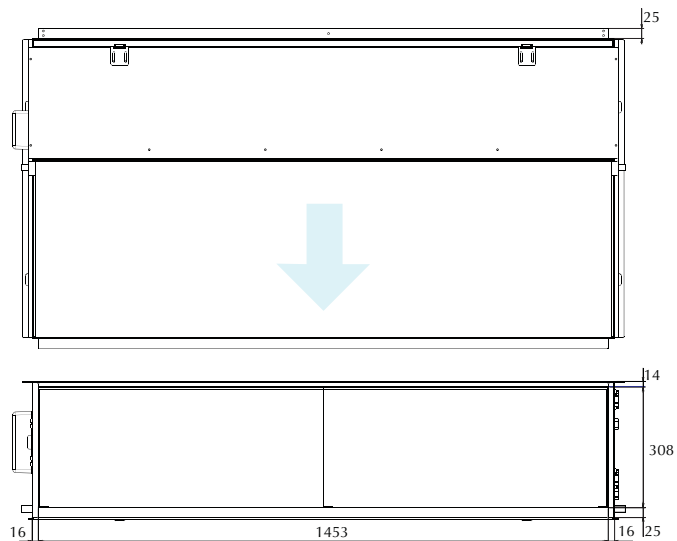
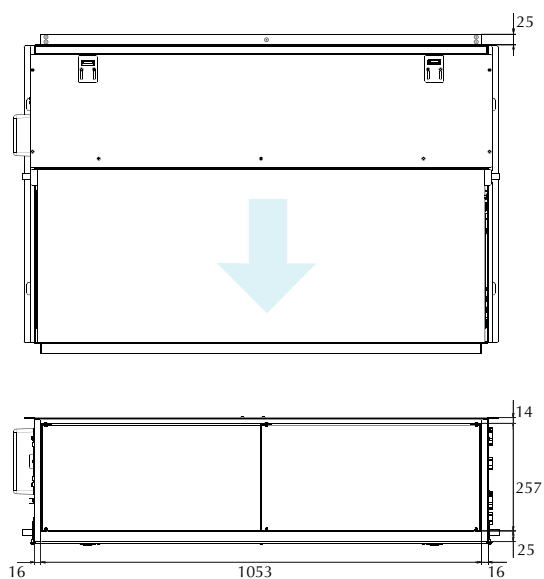

INSTALLATION

RDA_V allows to connect a channel with rectangular section to the intake vent of the VED unit. The filter, supplied as per standard with the VED unit, can be left in its original position or can be removed if an intake grid is used (not supplied) supplied with filter

INSTALLATION WITH STANDARD FILTER:

- Fix the RDA_V accessory directly to the unit intake vent using the four screws supplied. (fig.1 fig. 2)
- The filter remains in its original position and can be extracted for routine maintenance/replacement. (fig. 3)

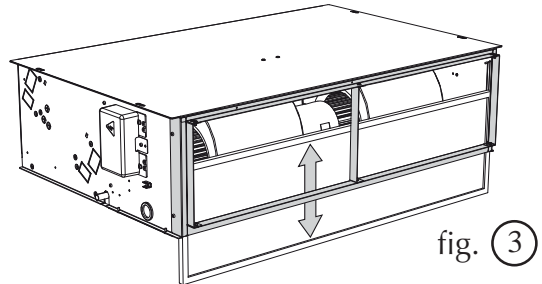
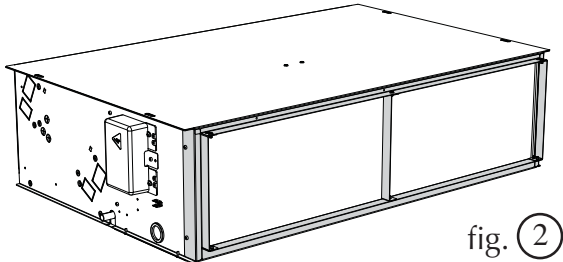
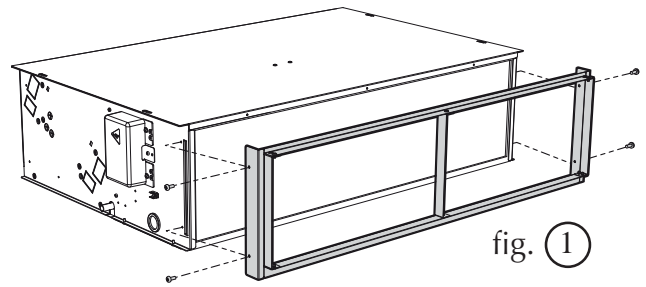

INSTALLATION WITHOUT STANDARD FILTER:

The following is necessary for installation without standard filter:

- Loosen the two filter retainers
- Slide the filter out of the unit (fig. 4)
- Remove the ventilation compartment closure panel (fig.5)
- Stick the adhesive side of the gasket (supplied) onto the bend of the closure panel of the ventilation compartment (fig.6)
- Re-mount the ventilation compartment closure panel (fig.7)
- Fix the RDA_V accessory to the unit intake vent using the four screws supplied .(fig.8-9).

- Complete installation by connecting the intake channel and the relative intake grid (not supplied) supplied with filter.

 The intake filter is always mandatory.

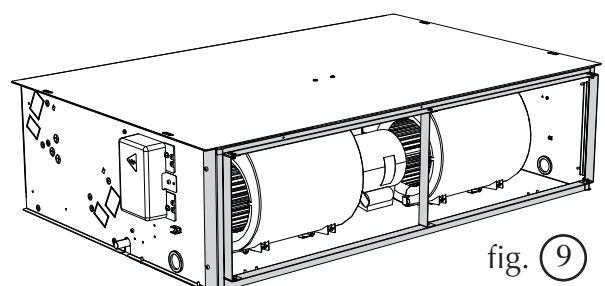
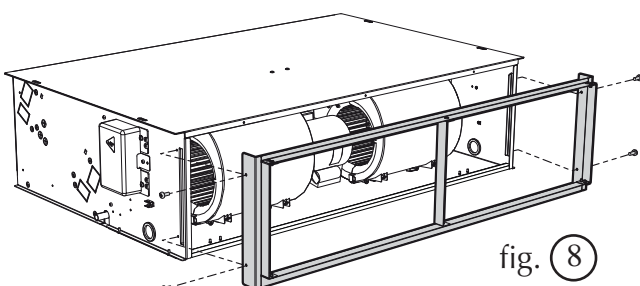
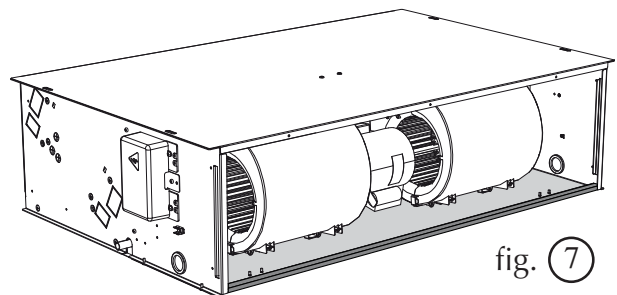
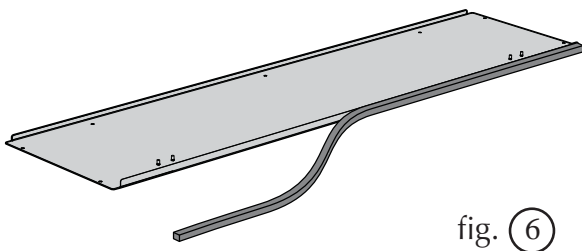
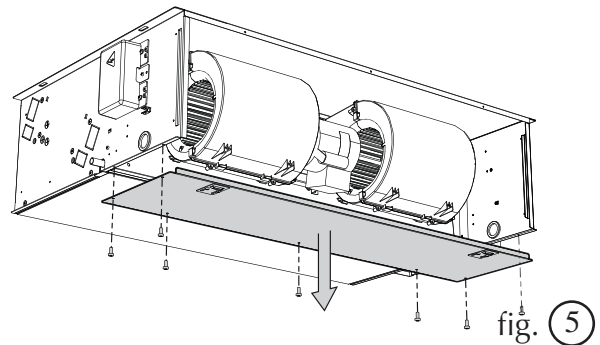
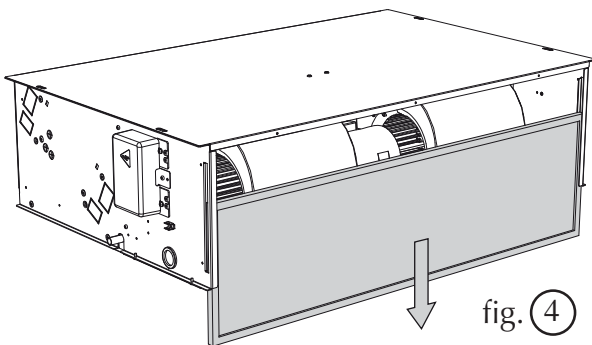

*I dati tecnici riportati nella presente documentazione non sono impegnativi.
AERMEC S.p.A Condizionatori S.p.A. si riserva la facoltà di apportare in qualsiasi
momento tutte le modifiche ritenute necessarie per il miglioramento del prodotto.*

*Technical data shown in this booklet are not binding.
AERMEC S.p.A Condizionatori S.p.A. shall have the right to introduce at any time
whatever modifications deemed necessary to the improvement of the product.*

*Les données figurant dans la présente documentation ne nous engagent pas. AERMEC
S.p.A. se réserve le droit d'apporter à tout moment toutes les modifications qu'elle
jugerait opportunes pour l'amélioration de son produit.*

*Im Sinne des technischen Fortschrittes behält sich AERMEC S.p.A. vor, in der
Produktion Änderungen und Verbesserungen ohne Ankündigung durchzuführen.*

AERMEC S.p.A.

37040 Bevilacqua (VR) - Italia
Via Roma, 996 - Tel. (+39) 0442 633111
Telefax (+39) 0442 93730 - 0442 93566
www.aermec.com
