



CHILLERS- Technical manual - installation - maintenance

NXW



EN



INXWPY. 1101. 4438805_04

Dear customer,

Thank you for choosing AERMEC. It is the fruit of many years of experience and special design studies and has been made of the highest grade materials and with cutting edge technology.

In addition, all our products bear the EC mark indicating that they meet the requirements of the European Machine Directive regarding safety. The quality level is being constantly monitored, so AERMEC products are synonymous with Safety, Quality and Reliability.

The data may undergo modifications considered necessary for the improvement of the product, at any time and without the obligation for any notice thereof.

Thank you again.
AERMEC S.p.A

Summary

1.	General warnings	6	15.	Sound data	34
1.1.	Storage of the documentation	6	15.1.	Sound levels of standard NXW version «°»	34
1.2.	Safety precautions and installation	6	15.2.	Sound levels of standard silenced version «L»	34
2.	Product identification	6	16.	Safety and check parameter setting	35
3.	Description and choice of the unit	7	17.	Capacity control	36
3.1.	Available models	7	18.	Selection and place of installation	38
3.2.	Available versions	7	19.	Positioning	38
3.3.	Available versions	7	19.1.	Minimum technical spaces (mm)	38
3.4.	Description and choice of the unit	8	20.	Dimensional tables	39
4.	Description of components	9	21.	Hydraulic circuit	50
4.1.	Cooling circuit	9	21.1.	External hydraulic circuit recommended	50
4.2.	Frame	9	21.2.	System load	50
4.3.	Hydraulic components	9	21.3.	Emptying the system	50
4.4.	Electrical components	9	22.	Percentage distribution of weights on supports ..	51
4.5.	Electronic regulation	9	22.1.	Percentage distribution of weights on supports (version ° - size from 0500 to 0750)	51
5.	Accessories	11	22.2.	Percentage distribution of weights on supports (version ° - sizes from 0800 to 1400)	52
5.1.	Electric regulation accessories	11	22.3.	Percentage distribution of weights on supports (version H - sizes from 0500 to 0750)	53
5.2.	Electrical accessories	11	22.4.	Percentage distribution of weights on supports (version H - sizes from 0800 to 1400)	54
5.3.	General accessories	11	22.5.	Percentage distribution of weights on supports (version L - sizes from 0500 to 0750)	55
6.	Technical data	13	22.6.	Percentage distribution of weights on supports (version L - sizes from 0800 to 1400)	56
6.1.	Standard version ° (standard) - L (silenced)	13	22.7.	Percentage distribution of weights on supports (version HL - sizes from 0500 to 750)	57
6.2.	Version H (heat pump with water side inversion) Version HL (heat pump with water side inversion - silenced)	15	22.8.	Percentage distribution of weights on supports (version HL - sizes from 0800 to 1400)	58
6.3.	Version E (condenserless)	17	22.9.	Percentage distribution of weights on supports version total recovery (T) all size	59
	Version L E (condenserless - silenced)	17	22.10.	Percentage distribution of weights on supports version silenced mode with total recovery (T) all size ..	59
7.	Operating limits	18	22.11.	Percentage distribution of weights on supports version condenserless (E)- all size	59
7.1.	Operating limits standard version	18	22.12.	Percentage distribution of weights on supports version condenserless - silenced mode (E)-all size	60
7.2.	Operating limit version E (condenserless)	18	23.	Electrical wirings	61
8.	Corrective factor	19	23.1.	Recommended section of electric cables	61
8.1.	Heating capacity and input power	19	23.2.	Connection to the power supply	63
8.2.	For ΔT different from the rated value	19	23.3.	Electrical power connection	63
8.3.	Fouling factors	19	23.4.	Auxiliary connections at the user/installer expense	63
8.4.	Cooling capacity and input power	20	24.	Control and first start-up	64
8.5.	For Δt different from the rated value	20	24.1.	Preparation for commissioning	64
8.6.	Fouling factors	20	24.2.	First commissioning of the machine	64
8.7.	Cooling capacity - input power version E (condenserless)	21	24.3.	Season changeover	64
8.8.	For Δt different from the rated value	21	25.	Operation characteristics	65
8.9.	Fouling factors	21	25.1.	Cooling set point	65
8.10.	Heating capacity with desuperheater	22	25.2.	Heating set point	65
8.11.	For Δt different from the rated value	22	25.3.	Compressor start-up delay	65
8.12.	Fouling factors	22	25.4.	Circulation pump	65
8.13.	Desuperheater pressure drops	22	25.5.	Anti-freeze alarm	65
8.14.	Heating capacity with total recovery	23	25.6.	Water flow rate alarm	65
8.15.	For Δt different from the rated value	23	26.	Regular maintenance	65
8.16.	Fouling factors	23	27.	Extraordinary maintenance	65
8.17.	Pressure drops total recovery	24	28.	Distributors	67
9.	Total pressure drops	25			
9.1.	Evaporator in cooling operation	25			
9.2.	Condenser in cooling operation	26			
10.	Useful heads	27			
11.	Minimum/maximum water content in the system ..	30			
12.	Expansion tank calibration	30			
13.	Glycol	31			
13.1.	How to read the glycol curves	31			
14.	Cooling lines	32			

NXW

SERIAL NUMBER

DECLARATION OF CONFORMITY

We, the undersigned, declare on our own exclusive responsibility that the object in question, so defined:

NAME NXW
TYPE WATER TO WATER CHILLER
MODEL

and to which this declaration refers, complies with the following harmonised standards:

CEI EN 60335-2-40	Safety regulation regarding electric heat pumps, air conditioners and dehumidifiers
CEI EN 61000-6-1	Electromagnetic immunity and emission in residential environment
CEI EN 61000-6-3	
CEI EN 61000-6-2	Electromagnetic immunity and emission in industrial environment
CEI EN 61000-6-4	
EN378	Refrigerating system and heat pumps - Safety and environmental requirements
UNI EN 12735	Round welding-free copper pipes for air conditioning and cooling
UNI EN 14276	Pressure equipment for refrigerating systems and heat pumps

thus meeting the essential requisites of the following directives:

- LVD Directive: 2006/95/EC
- Electromagnetic Compatibility Directive 2004/108/EC
- Machine Directive 2006/42/EC
- PED Directive relating to pressure equipment 97/23/EC

In compliance with Directive 97/23/EC, the product meets the Full quality assurance procedure (module H) with certificate no. 06/270-QT3664 Rev.5 issued by the notified body no. 1131 CEC via Pisacane 46 Legnano (MI) - Italy

The person authorised to compile the technical sheet is: Massimiliano Sfragara - 37040 Bevilacqua (VR) Italy - Via Roma, 996

Bevilacqua

20/05/2010

Marketing Director
Signature



Standards and directives to be followed in the design and manufacture of the unit:

Safety:

Machine Directive
2006/42/EC

Low voltage directive
LVD 2006/95/EC

Electromagnetic compatibility directive
EMC 2004/108/EC

Pressure containers directive
PED 97/23/CE EN 378,
UNI EN 14276

Electrical part:
EN 60204-1

Protection rating
IP20

Acoustic part:
SOUND POWER
(EN ISO 9614-2)
SOUND PRESSURE
(EN ISO 3744)

Certifications:
Eurovent

Refrigerant GAS: R410A

This unit contains fluorinated greenhouse gases covered by the Kyoto Protocol. Maintenance and disposal operations must be only carried out by qualified staff.

1. GENERAL WARNINGS

NXW AERMEC is built according to recognised technical standards and safety regulations. They have been designed for air conditioning and hot water production and must be used for this purpose in accordance with their performance characteristics. The company shall not be contractually or non-contractually liable for any damage to people, animals or objects, for failures caused by errors during installation, adjustment and maintenance or incorrect use. All the uses not expressly indicated in this manual are not allowed.

1.1. STORAGE OF THE DOCUMENTATION

Deliver the following instructions plus all the complementary documentation to the system user, who shall be responsible for keeping the instructions so that they are always available when needed.

Read carefully this chapter; all the procedures must be carried out by qualified personnel according to the regulations in force in the different countries (M.D. 329/2004).

The unit must be installed in such a way as to make all maintenance and/or repair operations possible.

The warranty of the device does not in any case cover costs owing to ladder trucks, lifts or other lifting systems that may be required in order to carry out repairs under warranty.

Do not modify or tamper with the chiller as this may cause dangerous situations and the manufacturer shall not be liable for any damages. The warranty shall not be valid if the indications mentioned above are not observed.

1.2. SAFETY PRECAUTIONS AND INSTALLATION

- the chiller must be installed by an authorised and qualified technician, in compliance with the national legislation in force in the country of destination (MD 329/2004).
AERMEC shall not be held responsible for any damage whatsoever resulting from the non-compliance with these instructions.
- Before starting any work, it is necessary TO READ CAREFULLY THE INSTRUCTIONS, AND TO PERFORM THE SAFETY CHECKS TO AVOID ANY RISKS. All the personnel in charge must be aware of the operations and the risks that may arise when all the unit installation operations begin.

2. PRODUCT IDENTIFICATION

NXW are identified by the following:

- PACKAGING LABEL
that includes the product identification data
- TECHNICAL PLATE
Placed on the right strut side (see fig.1)

NB

If the identification plate, or any other means to identify the product, is tampered with, removed or missing, installation and maintenance operations are hampered

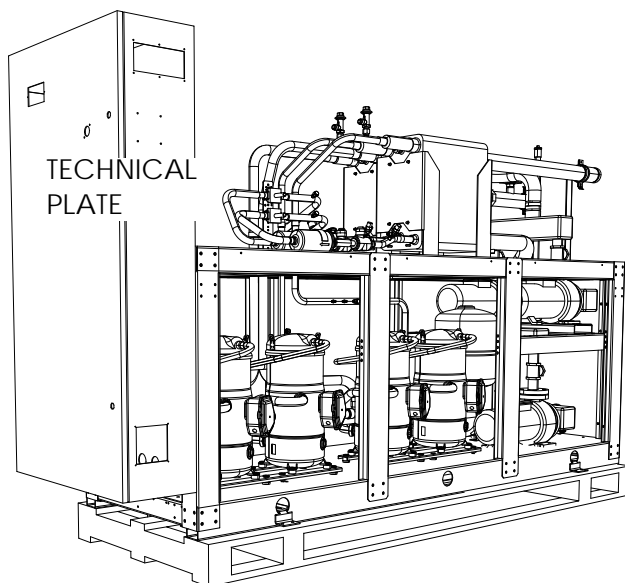

fig.1 technical plate

3. DESCRIPTION AND CHOICE OF THE UNIT

The NXW Heat pumps and reversible water-water FOR INDOOR INSTALLATION have been designed to completely satisfy any plant and application needs thanks to a wide range of models, configurations and accessories.

For years Aermec has been attentive to the energy efficiency issue, and has now designed the NXW units with the aim of ensuring high efficiency levels with both full and partial loads. The results are an EER > 5.05 and COP > 4.45 (Class A Eurovent). The NXW unit is commissioned and delivered completely charged with R410A refrigerant and oil (on site it will be necessary only to provide the hydraulic and electric connections), while the MOTO-CONDENSER <<E>> versions are delivered only with a watertight charge.

3.1. AVAILABLE MODELS

- Standard ° (heat pump with water side cycle inversion)
- Heat pump H(heat pump with gas side cycle inversion)

Extended operating limits:

- temperature of condenser output water up to 55°
- temperature of evaporator output water down to -8°

3.2. AVAILABLE VERSIONS

- **Standard °**
- **Silenced L**

Reduced sound emission thanks to total compressor casing of the machine with galvanised sheet metal panels of a suitable thickness and with good sound-absorbing capacity

Heat recovery units:

- Without recovery units °
- Desuperheater D: They are equipped with a partial plate heat recovery unit installed in series with the condenser.
- Total recovery T: They are equipped with a plate heat exchanger installed in parallel to the condenser for total recovery of the dissipated heat.

Condenser:

- Standard °
- Condenserless E

3.3. AVAILABLE VERSIONS

NXW range chillers are available in 11 sizes. By combining the wide variety of available options, it is possible to configure each model in the NXW range in such a way as to meet the most varied system requirements. To make installation easier, the machine can be provided with an hydronic kit evaporator and hydronic kit condenser, optimising spaces, times and installation costs. The following configurator shows the methods by which the commercial code of 15 fields that make it up representing the options available is compiled.

3.4. DESCRIPTION AND CHOICE OF THE UNIT

1 2 3	4 5 6 7	8	9	10	11	12	13	14	15
NXW	0650	°	°	°	°	°	°	°	°

Field:

1 2 3	Code	NXW
4 5 6 7	Size:	0500, 0550, 0600, 0650, 0700, 0750, 0800, 0900, 1000, 1250, 1400
8	Field of use:	
	°	Standard mechanical thermostatic valve up to +4°C
	Y	Low water temperature mechanical thermostatic valve down to -8°C
	X	Electronic thermostatic valve also for low water temperature (down to -8°C)
9	Model:	
	°	heat pump with water side inversion
	H	heat pump with gas side cycle inversion
10	Version:	
	°	standard
	L	silenced
11	Evaporator:	
	°	standard
	E	condenserless
12	Heat recovery	
	°	without recovery units
	D	with desuperheater
	T	with total heat recovery
13	Power supply	
	°	400V 3 50Hz with thermomagnetic switches
	4	230V 3 50Hz with thermomagnetic switches*
	5	500V 3 50Hz with thermomagnetic switches**
14	Evaporator side pumps	
	°	without pumping assembly
	M	low-head pump
	N	low-head pump and reserve pump
	O	high-head pump
	P	high-head pump and reserve pump
15	Condenser side pumps	
	°	without pumping assembly
	U	low-head pump
	V	low-head pump and reserve pump
	W	high-head pump
	Z	high-head pump and reserve pump
	J	low-head inverter pump
	K	high-head inverter pump

- the standard options are shown by the symbol °;

- these combinations are not possible: YD, YT HE, HT, ET, T with evaporator or condenser side pumps

* available only for sizes 0500 to 0700

** available only for sizes 0600 - 0650 and 0800 to 1400

*** "evaporator" is the heat exchanger that works as such in cooling mode; "condenser" is the heat exchanger that works as such in heating mode

4. DESCRIPTION OF COMPONENTS

4.1. COOLING CIRCUIT

Compressor

Scroll-type hermetic compressors fitted with electrical carter compressors heating elements as standard. The heating element is powered automatically when the unit is still provided the unit is kept powered up.

Evaporator

Plate type (AISI 316). It is insulated externally with closed cell material to reduce thermal dispersions.

Condensers

Plate type (AISI 316). It is insulated externally with closed cell material to reduce thermal dispersions.

Filter-drier

Of the mechanical cartridge type, made of ceramics and hygroscopic material able to trap impurities and any traces of humidity in the cooling circuit.

Liquid separator (for E version only)

Located on the suction point of the compressor, to protect against any flow-back of liquid refrigerant, flooded start-ups, operation in the presence of liquid

Liquid indicator

One per circuit, for checking the refrigerant gas load and any humidity in the cooling circuit.

Thermostatic valve

The valve with external equaliser on the output of the evaporator, modulates the gas flow to the evaporator in accordance with the heat load in such a way as to assure a sufficient degree of overheating at the intake gas.

Taps

They are located in the liquid and discharge lines and allow to intercept the refrigerant in case of extraordinary maintenance.

Solenoid valve

The valve closes when the compressor turns off, preventing the flow of refrigerant gas towards the evaporator.

4.2. FRAME

Load-bearing structure realised in suitably thick heat galvanized steel sheets, it is painted with polyester dust to guarantee resistance to atmospheric agents (RAL 9002)

SOUND PROTECTION COVERING (Only

silenced versions)

It is comprised of panels in suitably thick galvanized sheet metal and internally finished with sound-proofing material. Allows the sound power level emitted from the unit to be reduced by 6 db(A).

4.3. HYDRAULIC COMPONENTS

Flow switch (installed on the versions with a pump).

Its job is to make sure that there is water circulation in the evaporator. If this is not the case, it shuts down the unit.

NOTE:

In the heat pump version, there is a second flow switch (condenser side)

Circulation pump (Condenser/Evaporator)

Depending on the characteristics of the pump chosen, it offers a useful head to overcome the pressure drops in the system. There is also the possibility to have a reserve pump. The reserve pump is managed by the electronic card.

Water filter

versions standard: NOT INCLUDED
versions with a pumps: INCLUDED
Allows you to block and eliminate any impurities in the hydraulic circuits. Inside, it has a filtering mesh with holes not greater than one millimetre. It is indispensable to avoid serious damage to the plate heat exchanger. *NB The filter protects only the exchangers (in case of particularly dirty water, we recommend an external filter to protect the pumps)*

Drain valve

(versions with water accumulator or pump)

Of the automatic type, assembled on the upper part of the hydraulic system; it releases any air bubbles that may be present in the system.

Expansion tank 25 litres (standard in the version with pump)

With nitrogen pre-load membrane. In the version [°] is positioned on the evaporator, while in the version [H] is positioned on the heat exchanger that works as evaporator in cooling mode

SAFETY AND CONTROL COMPONENTS

Low pressure transducer

Allows displaying, on the microprocessor board display, the value of the compressor's suction pressure (one per circuit) on the low-pressure side of the cooling circuit

High pressure transducer

Allows displaying, on the microprocessor board display, the value of the compressor's delivery pressure (one per circuit) On the high pressure side of the cooling circuit

High pressure switch

Factory-calibrated, it is placed on the

high pressure side of the cooling circuit, it shuts down compressor operation in the case of abnormal operating pressure.

Cooling circuit safety valves (HP)

Calibrated at 45 bar HP, they cut in relieving the overpressure in the case of abnormal operating pressures.

Thermomagnetic switches to protect the compressors.

4.4. ELECTRICAL COMPONENTS

Electrical panel

Contains the power section and the management of the controls and safety devices.

Door-block disconnecting switch

It is possible to access the electrical panel by disconnecting the voltage, then using the opening lever of the panel itself. This lever can be blocked with one or more padlocks during maintenance, in order to prevent the machine being powered up accidentally.

Control keypad

Provides full control functions.

NB

For a more detailed description refer to the user manual.

4.5. ELECTRONIC REGULATION

Electronic regulation on the NXW chillers consists of a control board and a control panel with display. On each board transducers, loads and alarms are connected. The programme and parameter presets are stored permanently in the controller's FLASH memory, to ensure that they are kept in memory even when the system is not powered (without the need for an auxiliary battery).

The connection to the serial supervision assistance line in accordance with the **RS485** standard, is performed through the serial boards **ACCESSORY RS485P1** and the communication protocol.

- The terminal, which is always controlled by microprocessor, is equipped with a display, a keypad and a set of LEDs, and is used for programming check parameters (Set Points, differential band, alarm threshold) and for fundamental user operations (ON/OFF, display of controlled values).

The terminal does not need to be con-

nected to the PGD1 for normal controller operation, and is necessary only when initially programming the basic parameters.

Microprocessor

- Multilingual menu
- Phase sequence control
- Independent control of individual compressors
- Ammetric transformer
- Cumulative failure block signalling
- Alarm log function
- Daily/weekly programming
- Inlet/outlet water temperature display
- Alarm display
- Full proportional regulation of the output water temperature
- Programmable timer function
- Interfaceability with the Modbus protocol (accessory)
- Control and management of pump/s rotation
- Compressor rotation control
- Analogue input from 4 to 20 mA
- "Always Working" function. In case of critical conditions the machine does not arrest but is able to self-adjust itself and provide maximum output power in those conditions
- Self adapting operating differential "Switching Histeresys" to ensure correct compressor operation at all times even in plants with a low wa-

ter content or insufficient flow rates. This system reduces the compressor wear

- The PDC "Pull Down Control" system to prevent the activation of the power steps when the water temperature is approaching the set point quickly. It optimises the operation of the machine both when running normally or when there are load variations, thereby assuring top machine efficiency in all situations.

For further information, refer to the user manual.

Example of NXW version [°]

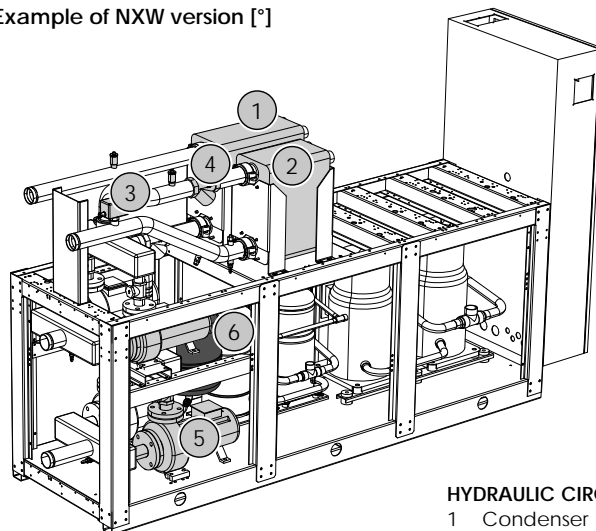

HYDRAULIC CIRCUIT KEY

- 1 Condenser
- 2 Evaporator (plate-type exchangers)
- 3 Flow switch
- 4 Filter
- 5 Pump
- 6 Expansion tank

NB

The Victaulic joints and the soldering studs for the condenser and evaporator are provided

5. ACCESSORIES

5.1. ELECTRIC REGULATION ACCESSORIES

- **AER485P1:** Through this accessory, it is possible to connect the unit with BMS supervision systems with electrical standard RS 485 and MODBUS type protocol
NOTE: disclosure must be provided for compressor No. 1 .
- **PGD1:** In addition to the control terminal on board the machine itself, NXW machines can also be equipped with an external PGD1

remote control terminal. PGD1 remote terminals provide the same functions as the on-board terminals (keyboard controls and display).

- PGD1 terminals can be installed at distances of up to 1 km from the machine (up to 50 meters with telephone cable AWG24, for distances of over 50 metres ensure that the 2nd extension card is powered by a voltage between 21 and 30 V dc.

5.2. ELECTRICAL ACCESSORIES

- **RIF:** Current phase advancer. Parallel connection with the motor makes the reduction of input current possible.

It can only be installed when the machine is being made and must therefore be specified when the order is placed.

- **DRE:** It permits the reduction of the starting current needed by the machine in the start up phase. This accessory can only be applied in the factory.

5.3. GENERAL ACCESSORIES

- **AVX:** spring anti-vibration supports

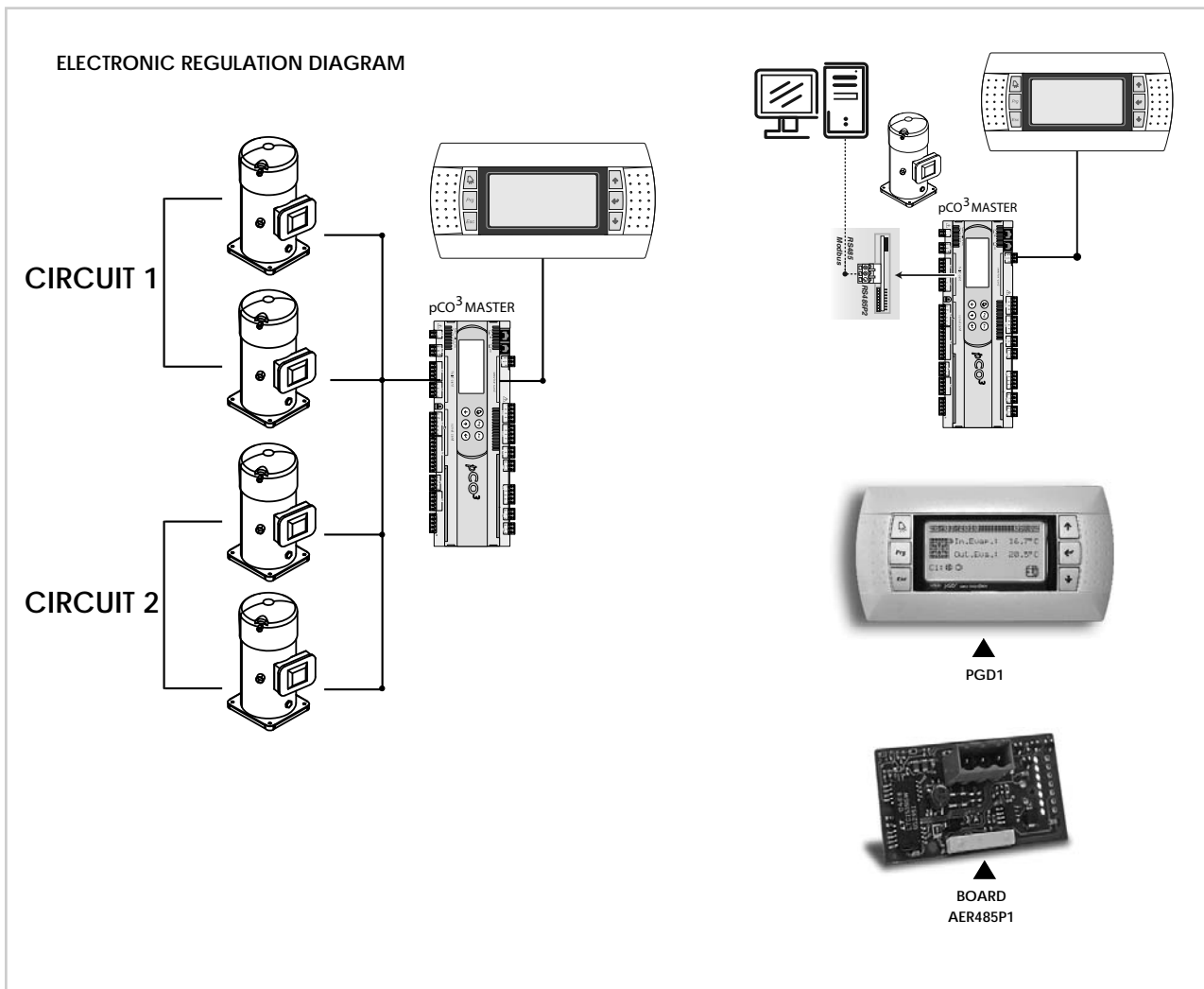

COMPATIBILITY OF ACCESSORIES

NXW	0500	0550	0600	0650	0700	0750	0800	0900	1000	1250	1400
AER485P1	Through this accessory it is possible to connect the unit with BMS supervision systems with electrical standard RS 485 and MODBUS type protocol.										
ALL	•	•	•	•	•	•	•	•	•	•	•
PGD1	REMOTE CONTROL TERMINAL PGD1										
	•	•	•	•	•	•	•	•	•	•	•
AVX	Rubber antivibration support. Select the model using the compatibility table.										
°	319	319	301	301	301	303	310	314	316	316	315
° + 1 PUMP	320	320	320	320	320	312	651	665	653	654	654
° + 2 PUMPS	320	320	309	309	309	312	651	665	653	654	654
° + 3 PUMPS	320	320	309	309	309	312	651	665	653	654	654
° + 4 PUMPS	309	309	310	310	310	312	651	665	653	654	654
H	319	319	301	301	302	310	310	314	316	315	317
H + 1 PUMP	320	320	320	309	309	651	651	665	654	654	654
H + 2 PUMPS	320	320	303	309	311	651	651	665	654	654	654
H + 3 PUMPS	309	309	303	311	312	651	651	665	654	654	654
H + 4 PUMPS	309	309	312	312	312	651	651	665	654	654	654
L	309	309	310	303	303	310	314	314	315	315	317
L + 1 PUMP	321	321	311	311	651	651	652	653	654	659	659
L + 2 PUMPS	311	311	31	311	651	651	652	653	654	659	659
L + 3 PUMPS	311	311	312	312	651	651	652	653	654	659	659
L + 4 PUMPS	312	312	312	310	651	651	652	653	654	659	659
HL	309	309	310	303	304	314	314	315	317	317	318
H L + 1 PUMP	311	311	311	311	651	652	665	653	659	659	659
H L + 2 PUMPS	311	311	312	313	651	652	665	653	659	659	659
H L + 3 PUMPS	312	312	312	313	651	652	665	653	659	659	659
H L + 4 PUMPS	312	312	312	313	651	652	665	653	659	659	659
E	319	319	301	301	301	303	310	314	316	316	315
E + 1 PUMP	320	320	320	320	320	312	651	665	653	654	654
E + 2 PUMPS	320	320	309	309	309	312	651	665	653	654	654
E + 3 PUMPS	320	320	309	309	309	312	651	665	653	654	654
E + 4 PUMPS	309	309	310	310	310	312	651	665	653	654	654
LE	309	309	310	303	303	310	314	314	315	315	317
L E + 1 PUMPS	321	321	311	311	651	651	652	653	654	659	659
L E + 2 PUMPS	311	311	31	311	651	651	652	653	654	659	659
L E + 3 PUMPS	311	311	312	312	651	651	652	653	654	659	659
L E + 4 PUMPS	312	312	312	310	651	651	652	653	654	659	659
T	303	303	310	310	310	314	652	315	322	322	322
L T	312	312	651	651	652	652	652	323	324	324	324
RIF	Current phase advancer. Parallel connection with the motor makes the reduction of input current possible. It can only be installed when the machine is being made and must therefore be specified when the order is placed.										
ALL	RIF98	RIF98	RIF95	RIF95	RIF95	RIF95	RIF95	RIF95	RIF96	RIF97	RIF97
DRE	It permits the reduction of the starting current needed by the machine in the start up phase. This accessory can only be applied in the factory.										
ALL	DRE501	DRE551	DRE601	DRE651	DRE701	DRE751	DRE801	DRE901	DRE1001	DRE1251	DRE1401

6. TECHNICAL DATA

6.1. STANDARD VERSION ° (STANDARD) - L (SILENCED) SIZE 0500-0550-0600-0650-0700-0800-0900-1000-1250-1400

Mod. NXW	vers	U.M.	0500	0550	0600	0650	0700	0750	0800	0900	1000	1250	1400
Cooling capacity [1]	° - L	kW	112	121	149	167	189	223	258	292	326	355	385
Total input power		kW	22.2	23.9	29.5	32.9	37.3	43.6	50.4	57.8	64.5	70.3	76.1
Evaporator water flow rate		l/h	19264	20812	25628	28758	32458	38392	44325	50188	56050	61097	66142
Evaporator pressure drop		kPa	30	35	32	40	43	47	49	55	35	36	36
Condenser water flow rate		l/h	22892	24718	30449	34141	38548	45511	52565	59629	66594	72590	78585
Pressure drop at condenser		kPa	25	29	29	37	37	45	60	38	29	34	36
Heating capacity [2]	° - L	kW	119	129	161	181	205	242	279	318	356	388	419
Total input power		kW	26.5	28.6	35.7	40.0	45.5	53.5	61.8	70.4	79.2	86.2	93.2
Condenser water flow rate		l/h	20468	22188	27692	31215	35195	41595	47995	54638	61281	66656	72030
Pressure drop at condenser		kPa	20	23	24	31	31	38	50	32	25	29	30
Evaporator water flow rate		l/h	16138	17515	21859	24681	27763	32850	37904	43140	48340	52574	56807
Evaporator pressure drop		kPa	21	25	23	29	31	34	36	41	26	27	27
ENERGY INDEXES													
EER	° - L	W/W	5.05	5.06	5.05	5.08	5.06	5.12	5.11	5.05	5.05	5.05	5.05
ESEER		W/W	6.01	6.02	6.01	6.04	6.02	6.05	6.03	6.02	6.06	6.05	6.06
COP	° - L	W/W	4.49	4.51	4.51	4.54	4.50	4.52	4.52	4.51	4.50	4.50	4.50
ELECTRICAL DATA													
400V 3 50Hz													
Input current (cooling)	° - L	A	48.3	50.6	58.4	63	86	94	102	120	138	140	143
Input current (heating)		A	54	57	66	72	94	105	115	135	154	160	165
Maximum current(FLA)		A	75	80	96	107	122	146	169	193	217	231	248
Starting current(LRA)		A	240	245	227	238	289	319	341	398	422	490	504
CHARGE - This data is subject to variations													
Refrigerant R410A(C1/C2)	° - L	kg	6.0/6.0	6.0/6.0	7.8/7.8	7.8/7.8	9.0/9.0	10.0/10.0	12.0/12.0	16.0/16.0	24.0/24.0	25.0/25.0	27.0/27.0
Oil Circuit (C1/C2)		dm ³	6.6/3.6	6.6/3.6	6.6/6.6	6.6/6.6	7.2/7.2	13.4/7.2	13.4/13.4	13.4/13.4	13.4/13.4	13.9/13.9	13.9/13.9
COMPRESSOR (SCROLL)													
N° of compressors/circuits	° - L	n°/n°	3/2				4/2						
EVAPORATOR (plates)													
Quantity	° - L	n°	1										
Water content		L	7.0	7.0	9.5	9.5	10.4	12.3	14.8	16.7	30.2	32.9	37.4
Victaulic water connections		Ø	2"1/2	2"1/2	2"1/2	2"1/2	2"1/2	2"1/2	2"1/2	2"1/2	2"1/2	3"	3"
CONDENSER (plates)													
Quantity	° - L	n°	1										
Water content		L	9.5	9.5	12.3	12.3	14.8	16.7	16.7	30.2	45.5	45.5	49.9
Victaulic water connections		Ø	2"1/2	2"1/2	2"1/2	2"1/2	2"1/2	2"1/2	2"1/2	2"1/2	2"1/2	3"	3"
HEAT RECOVERY (PLATE HEAT)													
Recovered heating capacity	° - L	kW	120	130	162	183	206	244	281	320	359	390	422
Quantity		n°	1										
Total input power		kW	28.9	31.1	38.9	43.5	49.5	58.3	67.3	76.6	86.2	93.8	101.5
Water flow rate recovery		l/h	20610	22340	27890	31430	35440	41890	48330	55020	61710	67120	72530
Pressure drops of the recovery exchanger		kPa	20	23	24	31	31	38	51	32	25	29	30
Water connections (VICTAULIC)		Ø	2"1/2	2"1/2	2"1/2	2"1/2	2"1/2	2"1/2	2"1/2	2"1/2	2"1/2	3"	3"

Reference data

In cooling operation [1]

processed water temperature
 Condenser inlet water temperature
 Δt

In heating operation [2]

processed water temperature
 Evaporator inlet water temperature
 Δt

45°C
 10°C
 5°C

Total recovery

Water temperature to total recovery 45°/50°C
 Water temperature to evaporator 12°/7°C

Mod. NXW	vers	U.M.	0500	0550	0600	0650	0700	0750	0800	0900	1000	1250	1400
DESUPERHEATER (PLATES)													
Recovered heating capacity	° - L	kW	21.0	22.6	27.2	29.0	32.4	37.6	43.0	49.1	55.0	59.4	62.0
Quantity		n°	1										
Desuperheater water flow rate		l/h	3620	3890	4680	4990	5570	6460	7390	8450	9460	10210	10660
Desuperheater pressure drops		kPa	2.0	2.3	3.3	3.8	4.7	6.4	8.3	2.4	3.0	3.5	3.8
Water connections (VICTAULIC)		Ø	2"	2"	2"	2"	2"	2"	2"	2"	2"	2"	2"
EVAPORATOR SIDE PUMPS													
Input power	M, N	Kw	1.1	1.1	1.1	1.5	1.5	2.2	2.2	2.2	2.2	3.0	3.0
	O, P		2.2	2.2	2.2	3.0	3.0	3.0	4.0	4.0	4.0	4.0	4.0
Input current	M, N	A	2.6	2.6	2.6	3.4	3.4	5.0	5.0	5.0	5.0	6.2	6.2
	O, P		5.0	5.0	5.0	6.2	6.2	6.2	8.1	8.1	8.1	8.1	8.1
Evaporator useful head * LP	M, N	kPa	91	82	70	89	69	102	86	68	74	102	88
Evaporator useful head * HP	O, P	kPa	181	173	167	213	191	152	180	166	177	167	158
CONDENSER SIDE PUMPS													
Input power	U, V, J	Kw	1.1	1.1	1.5	1.5	2.2	2.2	3.0	3.0	3.0	3.0	4.0
	W, Z, K		2.2	2.2	2.2	3.0	3.0	4.0	4.0	4.0	5.5	5.5	5.5
Input current	U, V, J	A	2.6	2.6	3.4	3.4	5.0	5.0	6.2	6.2	6.2	6.2	8.1
	W, Z, K		5.0	5.0	5.0	6.2	6.2	8.1	8.1	8.1	11.0	11.0	11.0
Condenser useful head * LP	U, V, J	kPa	86	76	92	67	111	88	99	104	93	69	128
Condenser useful head * HP	W, Z, K	kPa	188	171	155	188	161	182	158	168	215	190	166
EXPANSION TANK													
Capacity	° - L	l	25	25	25	25	25	25	25	25	25	25	25
Calibration pressure		Bar	1,5	1,5	1,5	1,5	1,5	1,5	1,5	1,5	1,5	1,5	1,5
Quantity		n°	1	1	1	1	1	1	1	1	1	1	1
SOUND DATA													
Sound power (1)	°	dB(A)	78	79	79	80	82	86	88	88	88	90	90
Sound pressure (2)			46	47	47	48	50	54	56	56	56	58	58
Sound power (1)	L	dB(A)	72	73	73	74	76	80	82	82	82	84	84
Sound pressure (2)			40	41	41	42	44	48	50	50	50	52	52
DIMENSIONS													
Height	°	mm	1835	1835	1835	1835	1835	1775	1775	1820	1820	1820	1820
Width		mm	800	800	800	800	800	800	800	800	800	800	800
Depth		mm	1790	1790	1790	1790	1790	2090	2354	2354	2354	2354	2354
Weight		kg	578	582	682	690	727	882	989	1180	1417	1461	1539
Height	L	mm	1885	1885	1885	1885	1885	1885	1885	1885	1885	1885	1885
Width		mm	800	800	800	800	800	800	800	800	800	800	800
Depth		mm	2090	2090	2090	2090	2090	2090	2354	2354	2354	2354	2354
Weight		kg	750	755	854	863	900	1054	1187	1378	1615	1659	1737
Height	PUMPS °	mm	1775	1775	1775	1775	1775	1775	1775	1850	1850	1850	1850
Width		mm	800	800	800	800	800	800	800	800	800	800	800
Depth		mm	3020	3020	3020	3020	3020	3020	3420	3420	3420	3420	3420
Height	PUMPS L	mm	1885	1885	1885	1885	1885	1885	1885	1885	1885	1885	1885
Width		mm	800	800	800	800	800	800	800	800	800	800	800
Depth		mm	3020	3020	3020	3020	3020	3020	3420	3420	3420	3420	3420

* Performance values refer to cooling mode

Desuperheater

Water temperature to desuperheater 45°/50°C

Water temperature condenser 30°C/35°C

Water temperature evaporator 12°C/7°C

(1) SOUND POWER

Aermec determines the value of the sound power based on the measurements taken in accordance with standard 9614-2, with respect to the certification requirement Eurovent.

(2) SOUND PRESSURE

Sound pressure in free field on reflecting plane (direction fact. Q=2), at 10 metres distance from the external surface of the unit, in accordance with standard ISO 3744.

**6.2. VERSION H (HEAT PUMP WITH WATER SIDE INVERSION)
VERSION HL (HEAT PUMP WITH WATER SIDE INVERSION - SILENCED)
SIZE 0500-0550-0600-0650-0700-0800-0900-1000-1250-1400**

Mod. NXW	vers	U.M.	0500	0550	0600	0650	0700	0750	0800	0900	1000	1250	1400	
Cooling capacity [1]	H - HL	kW	106	114	141	160	181	212	243	278	314	342	370	
Total input power		kW	23.2	25.0	30.3	34.2	38.9	45.5	52.0	60.4	68.8	74.7	80.6	
Evaporator water flow rate		l/h	18232	19608	24252	27496	31095	36431	41768	47876	53985	58831	63676	
Evaporator pressure drop		kPa	17	20	19	24	24	29	38	24	19	22	24	
Condenser water flow rate		l/h	22023	23693	29203	33089	37444	43858	50272	57750	65229	71038	76847	
Pressure drop at condenser		kPa	25	29	28	35	35	42	55	36	28	32	34	
Heating capacity [2]	H - HL	kW	121	131	160	181	203	240	276	314	353	386	419	
Total input power		kW	27.2	29.4	35.9	40.4	45.5	53.8	62.1	70.6	79.2	86.7	94.1	
Condenser water flow rate		l/h	20812	22532	27520	31088	34982	41249	47515	54090	60665	66348	72030	
Pressure drop at condenser		kPa	22	26	24	31	30	37	49	31	24	28	30	
Evaporator water flow rate		l/h	16368	17728	21654	24488	27549	32461	37373	42548	47724	52189	56654	
Evaporator pressure drop		kPa	14	16	15	19	19	23	30	19	15	17	19	
ENERGY INDEXES														
EER	H - HL	W/W	4.57	4.56	4.65	4.67	4.65	4.66	4.67	4.61	4.56	4.58	4.59	
ESEER		W/W	5.73	5.71	5.76	5.85	5.76	5.79	5.64	5.72	5.85	5.77	5.80	
COP	H - HL	W/W	4.45	4.46	4.46	4.47	4.47	4.46	4.45	4.45	4.45	4.45	4.45	
ELECTRICAL DATA														
400V 3 50Hz														
Input current (cooling)	H - HL	A	49	52	60	65	87	95	104	122	140	144	147	
Input current (heating)		A	54	57	66	72	94	105	115	135	154	160	165	
Maximum current		A	75	80	96	107	122	146	169	193	217	231	248	
Starting current		A	240	245	227	238	289	319	341	398	422	490	504	
CHARGE - This data is subject to variations														
Refrigerant R410A (C1/C2)	H - HL	kg	6.5/6.5	6.5/6.5	8.5/8.5	8.5/8.5	10.0/10.0	11.0/11.0	13.0/13.0	18.0/18.0	27.0/27.0	27.0/27.0	29.0/29.0	
Oil Circuit (C1/C2)		dm ³	6.6/3.6	6.6/3.6	6.6/6.6	6.6/6.6	7.2/7.2	13.4/7.2	13.4/13.4	13.4/13.4	13.4/13.4	13.9/13.9	13.9/13.9	
COMPRESSOR (SCROLL)														
N° of compressors/circuits	H - HL	n°/n°	3/2					4/2						
EVAPORATOR (plates)														
Quantity	H - HL	n°	1											
Water content		L	9.5	9.5	12.3	12.3	14.8	16.7	16.7	30.2	45.5	45.5	49.9	
Victaulic water connections		Ø	2"1/2	2"1/2	2"1/2	2"1/2	2"1/2	2"1/2	2"1/2	2"1/2	3"	3"	3"	3"
CONDENSER (plates)														
Quantity	H - HL	n°	1											
Water content		L	9.5	9.5	12.3	12.3	14.8	16.7	16.7	30.2	45.5	45.5	49.9	
Victaulic water connections		Ø	2"1/2	2"1/2	2"1/2	2"1/2	2"1/2	2"1/2	2"1/2	2"1/2	3"	3"	3"	3"
HEAT RECOVERY (PLATE HEAT)														
Recovered heating capacity	Vers.	U.M.												
Quantity		H - HL	kW	120	130	162	183	206	244	281	320	359	390	422
Total input power			Ø	1										
Water flow rate recovery			kW	28.9	31.1	38.9	43.5	49.5	58.3	67.3	76.6	86.2	93.8	101.5
Pressure drops of the recovery exchanger			l/h	20610	22340	27890	31430	35440	41890	48330	55020	61710	67120	72530
Water connections (VICTAULIC)			kPa	20	23	24	31	31	38	51	32	25	29	30
	Ø		2"1/2	2"1/2	2"1/2	2"1/2	2"1/2	2"1/2	2"1/2	2"1/2	3"	3"	3"	3"

In cooling operation [1]

processed water temperature
Condenser inlet water temperature
Δt

7°C
30°C
5°C

In heating operation [2]

processed water temperature
Evaporator inlet water temperature
Δt

45°C
10°C
5°C

Total recovery

Water temperature to total recovery 45°/50°C
Water temperature to evaporator 12°/7°C

Mod. NXW	vers	U.M.	0500	0550	0600	0650	0700	0750	0800	0900	1000	1250	1400
DESUPERHEATER (PLATES)													
Recovered heating capacity	H - HL	(1) kW	21.0	22.6	27.2	29.0	32.4	37.6	43.0	49.1	55.0	59.4	62.0
Quantity		no.	1										
Desuperheater water flow rate		(1) l/h	3620	3890	4680	4990	5570	6460	7390	8450	9460	10210	10660
Desuperheater pressure drops		(1) kPa	2.0	2.3	3.3	3.8	4.7	6.4	8.3	2.4	3.0	3.5	3.8
Water connections (VICTAULIC)		diam	2"	2"	2"	2"	2"	2"	2"	2"	2"	2"	2"
Weight of the recovery exchanger		kg											
EVAPORATOR SIDE PUMPS													
Input power	M, N	Kw	1.1	1.1	1.1	1.5	1.5	2.2	2.2	2.2	2.2	3.0	3.0
	O, P		2.2	2.2	2.2	3.0	3.0	3.0	4.0	4.0	4.0	4.0	4.0
Input current	M, N	A	2.6	2.6	2.6	3.4	3.4	5.0	5.0	5.0	5.0	6.2	6.2
	O, P		5.0	5.0	5.0	6.2	6.2	6.2	8.1	8.1	8.1	8.1	8.1
Evaporator useful head * LP	M, N	kPa	107	102	88	110	95	131	102	104	95	121	108
Evaporator useful head * HP	O, P	kPa	202	192	183	235	217	182	194	200	197	185	175
CONDENSER SIDE PUMPS													
Input power	U, V, J	Kw	1.1	1.1	1.5	1.5	2.2	2.2	3.0	3.0	3.0	3.0	4.0
	W, Z, K		2.2	2.2	2.2	3.0	3.0	4.0	4.0	4.0	5.5	5.5	5.5
Input current	U, V, J	A	2.6	2.6	3.4	3.4	5.0	5.0	6.2	6.2	6.2	6.2	8.1
	W, Z, K		5.0	5.0	5.0	6.2	6.2	8.1	8.1	8.1	11.0	11.0	11.0
Condenser useful head * LP	U, V, J	kPa	90	81	100	75	120	94	109	111	99	76	135
Condenser useful head * HP	W, Z, K	kPa	191	176	161	196	170	187	166	174	221	198	176
EXPANSION TANK													
Capacity	H - HL	l	25	25	25	25	25	25	25	25	25	25	25
Pressure calibration		Bar	1,5	1,5	1,5	1,5	1,5	1,5	1,5	1,5	1,5	1,5	1,5
Quantity		n°	1	1	1	1	1	1	1	1	1	1	1
SOUND DATA													
Sound power (1)	H	dB(A)	78	79	79	80	82	86	88	88	88	90	90
Sound pressure (2)			46	47	47	48	50	54	56	56	56	56	58
Sound power (1)	H - HL	dB(A)	72	73	73	74	76	80	82	82	82	84	84
Sound pressure (2)			40	41	41	42	44	48	50	50	50	50	52
DIMENSIONS													
Height	H	mm	1835	1835	1835	1835	1835	1775	1775	1820	1820	1820	1820
Width		mm	800	800	800	800	800	800	800	800	800	800	800
Depth		mm	1790	1790	1790	1790	1790	2090	2354	2354	2354	2354	2354
Weight		kg	628	633	734	743	791	948	1042	1275	1545	1577	1657
Height	H-HL	mm	1885	1885	1885	1885	1885	1885	1885	1885	1885	1885	1885
Width		mm	800	800	800	800	800	800	800	800	800	800	800
Depth		mm	2090	2090	2090	2090	2090	2090	2354	2354	2354	2354	2354
Weight		kg	801	805	907	915	963	1121	1240	1473	1743	1775	1855
Height	PUMPS H	mm	1775	1775	1775	1775	1775	1775	1775	1850	1850	1850	1850
Width		mm	800	800	800	800	800	800	800	800	800	800	800
Depth		mm	3020	3020	3020	3020	3020	3020	3420	3420	3420	3420	3420
Height	PUMPS HL	mm	1885	1885	1885	1885	1885	1885	1885	1885	1885	1885	1885
Width		mm	800	800	800	800	800	800	800	800	800	800	800
Depth		mm	3020	3020	3020	3020	3020	3020	3420	3420	3420	3420	3420

* Performance values refer to cooling mode

Desuperheater

Water temperature to desuperheater 45°/50°C

Water temperature condenser 30°C/35°C

Water temperature evaporator 12°C/7°C

(1) SOUND POWER

Aermec determines the value of the sound power based on the measurements taken in accordance with standard 9614-2, with respect to the certification requirement Eurovent.

(2) SOUND PRESSURE

Sound pressure in free field on reflecting plane (direction fact. Q=2), at 10 metres distance from the external surface of the unit, in accordance with standard ISO 3744.

6.3. **VERSION E (CONDENSERLESS)**
VERSION L E (CONDENSERLESS - SILENCED)
SIZE 0500-0550-0600-0650-0700-0800-0900-1000-1250-1400

Mod. NXW	vers	U.M.	0500	0550	0600	0650	0700	0750	0800	0900	1000	1250	1400	
Cooling output (C1+C2)	E - LE	kW	105 (43,5+61,5)	113 (43,5+69,5)	139 (69,5+69,5)	156 (78+78)	177 (88,5+88,5)	209 (88,5+120,5)	241 (120,5+120,5)	273 (136,5+136,5)	305 (152,5+152,5)	332 (166+166)	360 (180+180)	
Total input power		kW	24.9	26.8	33.0	36.9	41.7	48.8	56.5	64.7	72.3	78.8	85.3	
Evaporator water flow rate		l/h	18031	19480	23988	26918	30381	35935	41488	46976	52463	57187	61909	
Evaporator pressure drop		kPa	26	31	28	35	38	41	43	48	31	32	32	
ENERGY INDEXES														
EER	E - LE	W/W	4.22	4.23	4.22	4.24	4.23	4.28	4.27	4.22	4.22	4.22	4.22	
ELECTRICAL DATA														
400V 3 50Hz														
Input current (cooling)	E - LE	A	54.1	56.7	65.4	70.6	96.3	105.3	114.2	134.4	154.6	156.8	160.2	
Maximum current		A	75	80	96	107	122	146	169	193	217	231	248	
Starting current		A	240	245	227	238	289	319	341	398	422	490	504	
OIL CHARGE														
Circuit (C1/C2)	E - LE	dm ³	6.6/3.6	6.6/3.6	6.6/6.6	6.6/6.6	7.2/7.2	13.4/7.2	13.4/13.4	13.4/13.4	13.4/13.4	13.9/13.9	13.9/13.9	
Refrigerant		dm ³	only with a watertight charge											
COMPRESSOR (SCROLL)														
N° of compressors/circuits	E - LE	n°/n°	3/2					4/2						
EVAPORATOR (plates)														
Quantity	E - LE	n°	1											
Water content		l	7.0	7.0	9.5	9.5	10.4	12.3	14.8	16.7	30.2	32.9	37.4	
Victaulic water connections		Ø	2"1/2	2"1/2	2"1/2	2"1/2	2"1/2	2"1/2	2"1/2	2"1/2	2"1/2	3"	3"	3"
SOUND DATA														
Sound power (1)	E	dB(A)	78	79	79	80	82	86	88	88	88	90	90	
Sound pressure (2)			46	47	47	48	50	54	56	56	56	56	58	58
Sound power (1)	E - LE	dB(A)	72	73	73	74	76	80	82	82	82	84	84	
Sound pressure (2)			40	41	41	42	44	48	50	50	50	50	52	52
DIMENSIONS														
Height	E	mm	1835	1835	1835	1835	1835	1775	1775	1775	1820	1820	1820	
Width		mm	800	800	800	800	800	800	800	800	800	800	800	
Depth		mm	1790	1790	1790	1790	1790	2090	2354	2354	2354	2354	2354	
Height	E - LE	mm	1885	1885	1885	1885	1885	1885	1885	1885	1885	1885	1885	
Width		mm	800	800	800	800	800	800	800	800	800	800	800	
Depth		mm	2090	2090	2090	2090	2090	2090	2090	2354	2354	2354	2354	

Reference data

processed water temperature 7°C
 Condensing temperature 45°C
 Δt 5°C

(1) SOUND POWER

Aermec determines the value of the sound power based on the measurements taken in accordance with standard 9614-2, with respect to the certification requirement Eurovent.

(2) SOUND PRESSURE

Sound pressure in free field on reflecting plane (direction fact. Q=2), at 10 metres distance from the external surface of the unit, in accordance with standard ISO 3744.

7. OPERATING LIMITS

7.1. OPERATING LIMITS STANDARD VERSION

Reference should be made to the diagram below for the operating limits. (see table 7.1.1)

The diagram for the operating limits is relative to all Δt on the evaporator and on the condenser of 5 °C.

Inlet (Δt_c) Output condenser:
min: 5
max: 15

Inlet (Δt_e) output difference Evaporator:
min: 3
max: 10

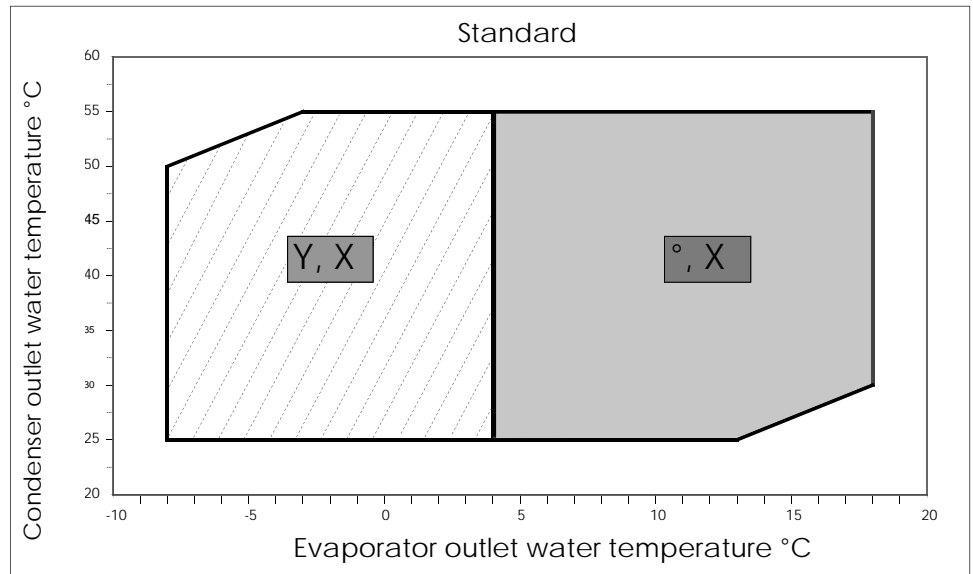



Tab. 7.1.1

7.2. OPERATING LIMIT VERSION E (CONDENSERLESS)

Reference should be made to the diagram below for the operating limits. (see table 7.1.1)

KEY:

 Operation with glycol

 Standard operation

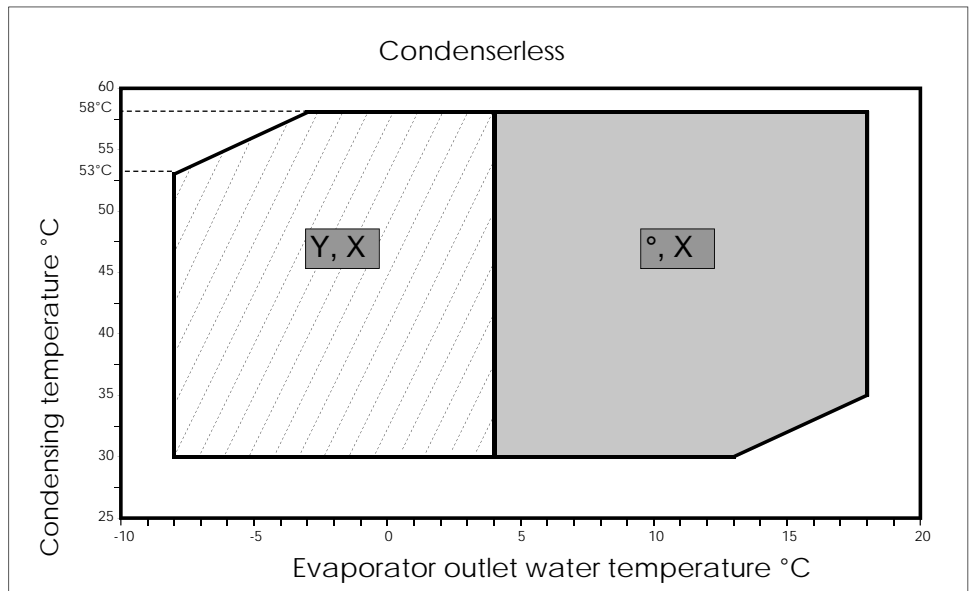

Tab. 7.2.1

° = with standard mechanical thermostatic valve up to +4°C

Y = Low water temperature mechanical thermostatic valve down to -6°C

X = Electronic thermostatic valve also for low water temperature (down to -6°C)

8.3 DESIGN DATA DIR 97/23/EC		HIGH PRESSURE SIDE	LOW PRESSURE SIDE
Maximum allowable pressure	bar	45	30
Maximum temperature allowable	°C	120	51
Minimum temperature allowable	°C	-30	-30

8. CORRECTIVE FACTOR

8.1. HEATING CAPACITY AND INPUT POWER

- "HEAT PUMP VERSIONS IN HEATING MODE"

The heating capacity yielded and the input electrical capacity in conditions other than rated conditions are obtained by multiplying the rated values (P_t , P_a) by the respective correction coefficients (C_t , C_a).

Diagram (Tab. 8.1.1) allows you to obtain the correction coefficients; corresponding to each curve, the temperature of the hot processed water referred to is reported, assuming a difference in water temperature between the input and output of the condenser equal to 5°C.

KEY:

C_t = Heating capacity correction coefficient

C_a = Input power correction coefficient

8.2. FOR ΔT DIFFERENT FROM THE RATED VALUE

For Δt different from 5°C to the evaporator, refer to Tab.8.2.1 for the cooling capacity and input power correction factors.

8.3. FOULING FACTORS

The performance levels indicated in table 8.3.1 refer to conditions with clean tubes, with a fouling factor = 1. For values different from the fouling factor, multiply the values in the performance table by the reported coefficients.

HEATING CAPACITY

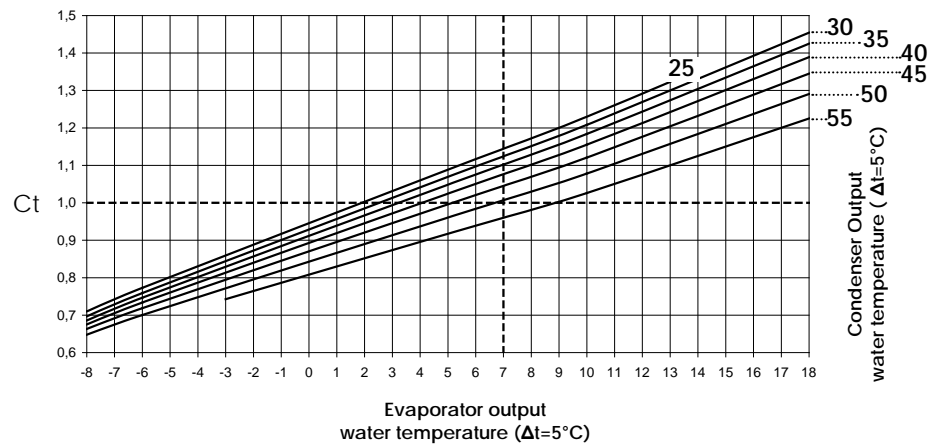

ABSORBED POWER (HEATING)

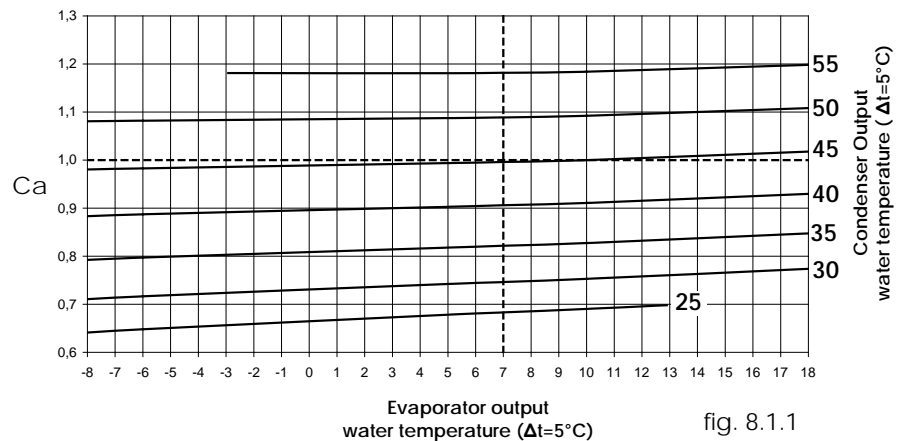

fig. 8.1.1

8.2.1 CORRECTION FACTORS FOR ΔT DIFFERENT FROM THE CHILLER RATED VALUE

Evaporator Δt different to nominal	3	5	8	10
Correction factor cooling capacity	0,99	1	1,02	1,03
Correction factor input power	0,99	1	1,01	1,02
Correction factor heating capacity	0,99	1	1,02	1,03
Condenser Δt different to nominal	3	5	8	10
Correction factor heating capacity	0.9912	1	1.013	1.0227
Correction factor input power	1.0144	1	0.978	0.9633

8.3.1 FOULING FACTOR

Fouling factor [$K \cdot m^2$]/[W]	0,00001	0,00002	0,00005
Correction factor cooling capacity	1	0,99	0,98
Correction factor input power	1	1	1
Correction factor heating capacity	1	1	0,99
Correction factor input power	1	1	1,02

8.4. COOLING CAPACITY AND INPUT POWER

- "HEATING PUMP IN COOLING OPERATION VERSIONS "

The refrigerating capacity yielded and the input electrical capacity in conditions other than rated conditions are obtained by multiplying the rated values (P_f , P_a) by the respective correction coefficients (C_f , C_a).

The diagram allows you to obtain the correction coefficients; corresponding to each curve, the temperature of the hot processed water referred to is reported, assuming a difference in water temperature between the input and output of the condenser equal to 5°C.

KEY:

- C_f = Cooling capacity correction coefficient
- C_a = Input power correction coefficient

8.5. FOR Δt DIFFERENT FROM THE RATED VALUE

For Δt different from 5°C to the evaporator, refer to Tab. 8.5.1 for the cooling capacity and input power correction factors.

8.6. FOULING FACTORS

The performance levels indicated in table 8.6.1 refer to conditions with clean tubes, with a fouling factor = 1. For values different from the fouling factor, multiply the values in the performance table by the reported coefficients.

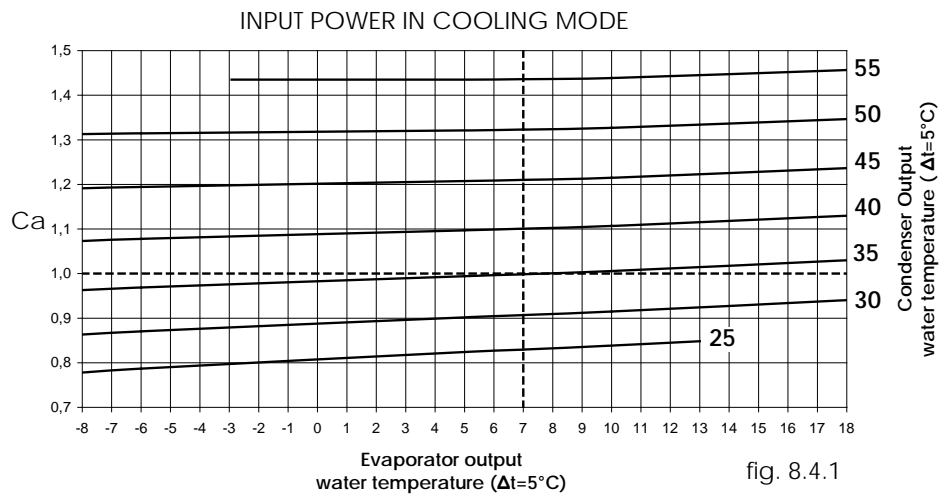
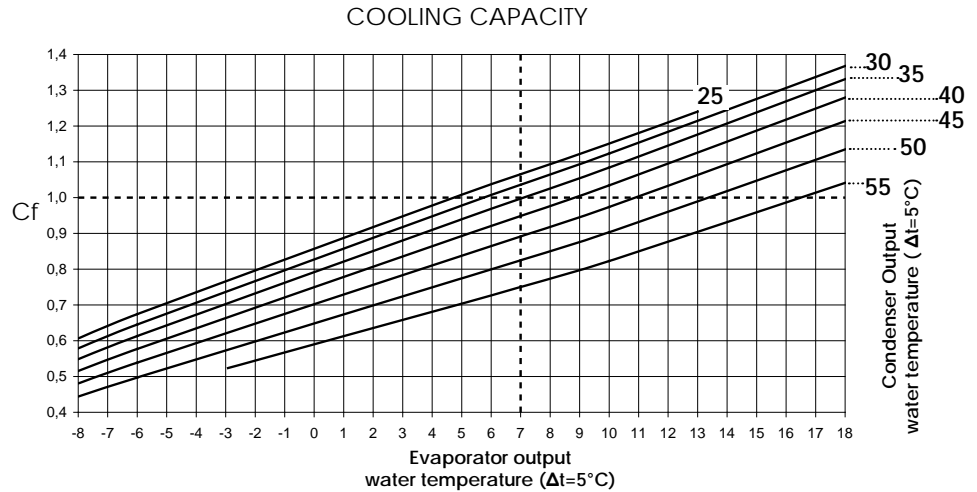

fig. 8.4.1

8.5.1 CORRECTION FACTORS FOR Δt DIFFERENT FROM THE CHILLER RATED VALUE

Evaporator Δt different to nominal	3	5	8	10
Correction factor cooling capacity	0,99	1	1,02	1,03
Correction factor input power	0,99	1	1,01	1,02
Correction factor heating capacity	0,99	1	1,02	1,03
Condenser Δt different to nominal	3	5	8	10
Correction factor heating capacity	0.9912	1	1.013	1.0227
Correction factor input power	1.0144	1	0.978	0.9633

8.6.1 FOULING FACTOR

Fouling factor [$K \cdot m^2 / W$]	0,00001	0,00002	0,00005
Correction factor cooling capacity	1	0,99	0,98
Correction factor input power	1	1	1
Correction factor heating capacity	1	1	0,99
Correction factor input power	1	1	1,02

8.7. COOLING CAPACITY - INPUT POWER VERSION E (CONDENSERLESS)

- "VERSIONS E (CONDENSERLESS)

The refrigerating capacity yielded and the input electrical capacity in conditions other than rated conditions are obtained by multiplying the rated values (Pf, Pa) by the respective correction coefficients (Cf, Ca).

The diagram allows you to obtain the correction coefficients; According to the condensing temperature of referred to is shown assuming a difference of 5°C between the input and output of the evaporator equal to 5°C.

KEY:

Cf = Cooling capacity correction coefficient

Ca = Input power correction coefficient

8.8. FOR Δt DIFFERENT FROM THE RATED VALUE

For Δt different from 5°C to the evaporator, refer to Tab.8.8.1 for the cooling capacity and input power correction factors.

8.9. FOULING FACTORS

The properties provided on table 8.9.1 refer to the conditions of clean pipes with a fouling factor = 1. For values different from the fouling factor, multiply the values in the performance table by the reported coefficients.

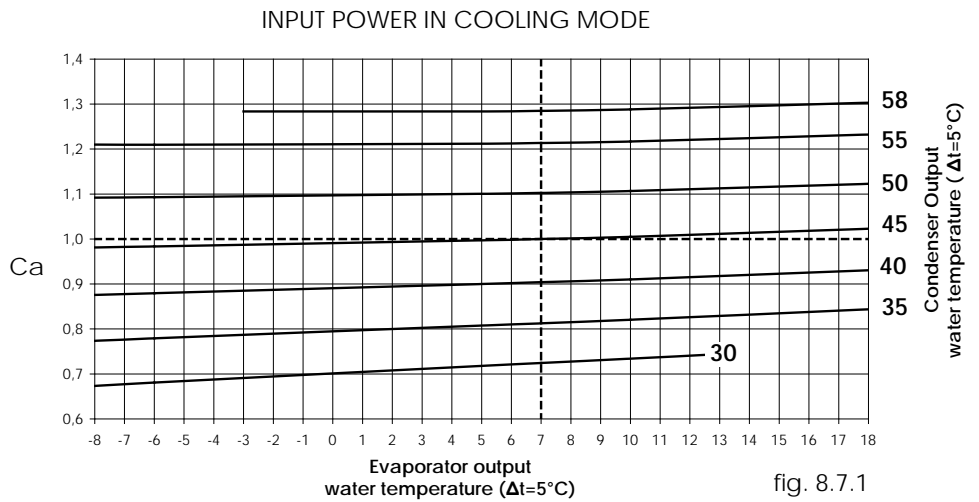
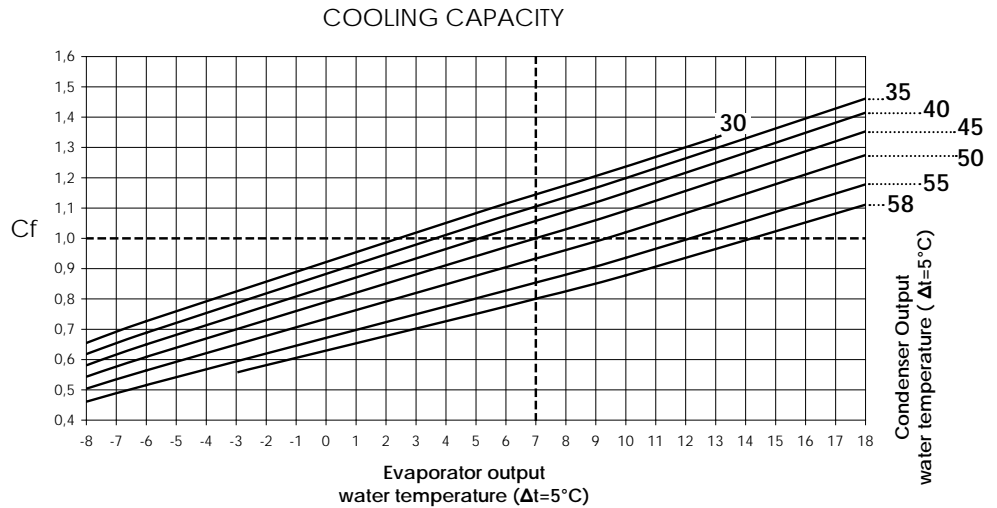

fig. 8.7.1

8.8.1 CORRECTION FACTORS FOR Δt DIFFERENT FROM THE CHILLER RATED VALUE

Evaporator Δt different to nominal	3	5	8	10
Correction factor cooling capacity	0,99	1	1,02	1,03
Correction factor input power	0,99	1	1,01	1,02
Correction factor heating capacity	0,99	1	1,02	1,03
Condenser Δt different to nominal	3	5	8	10
Correction factor heating capacity	0.9912	1	1.013	1.0227
Correction factor input power	1.0144	1	0.978	0.9633

8.9.1 FOULING FACTOR

Fouling factor [K*m²]/[W]	0,00001	0,00002	0,00005
Correction factor cooling capacity	1	0,99	0,98
Correction factor input power	1	1	1
Correction factor heating capacity	1	1	0,99
Correction factor input power	1	1	1,02

8.10. HEATING CAPACITY WITH DESUPERHEATER

The heating capacity yielded in conditions other than rated conditions are obtained by multiplying the rated values (Pt, Pa) by the respective correction coefficients (Cd).

Diagram (Tab. 8.10.1) allows you to obtain the correction coefficients; corresponding to each curve, the temperature of the hot processed water referred to is reported, assuming a difference in water temperature between the input and output of the condenser equal to 5°C.

KEY:

Cd = Heating capacity correction coefficient

8.11. FOR ΔT DIFFERENT FROM THE RATED VALUE

For Δt different from 5°C to the evaporator, refer to Tab.8.11.1 for the cooling capacity and input power correction factors.

8.12. FOULING FACTORS

The performance levels indicated in table 8.12.1 refer to conditions with clean tubes, with a fouling factor = 1. For values different from the fouling factor, multiply the values in the performance table by the reported coefficients.

8.13. DESUPERHEATER PRESSURE DROPS

The pressure drops in the charts refer to an average water temperature of 10 °C. The table(8.13.1) shows the corrections to apply to the pressure drops with a variation in average water temperature.

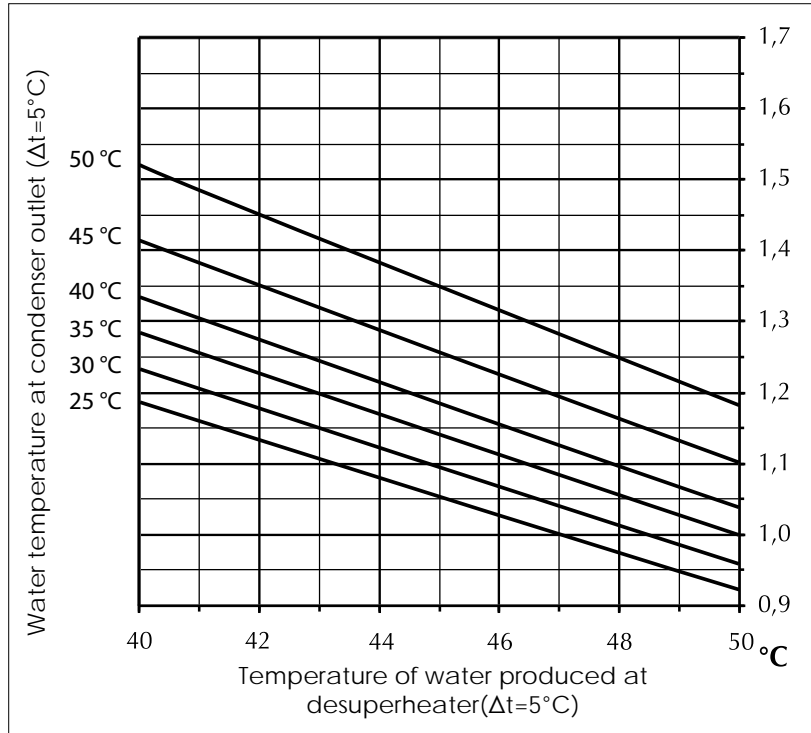

fig. 8.10.1

8.11.1 CORRECTION FACTORS FOR ΔT DIFFERENT FROM THE CHILLER RATED VALUE

Evaporator Δt different to nominal	3	5	8	10
Correction factor cooling capacity	0,99	1	1,02	1,03
Correction factor input power	0,99	1	1,01	1,02
Correction factor heating capacity	0,99	1	1,02	1,03
Condenser Δt different to nominal	3	5	8	10
Correction factor heating capacity	0,9912	1	1,013	1,0227
Correction factor input power	1,0144	1	0,978	0,9633

8.12.1 FOULING FACTOR

Fouling factor [K*m²]/[W]	0,00001	0,00002	0,00005
Correction factor cooling capacity	1	0,99	0,98
Correction factor input power	1	1	1
Correction factor heating capacity	1	1	0,99
Correction factor input power	1	1	1,02

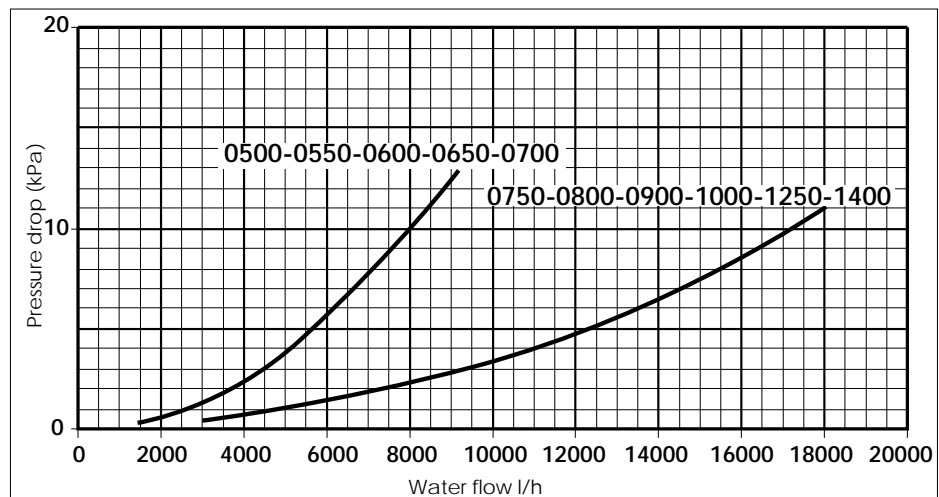

Average water temperature [°C]	5	10	15	20	30	40	50
Correction factor	1,22	1,10	1,08	1,06	1,04	1,02	1,00

Tab 8.13.1

8.14. HEATING CAPACITY WITH TOTAL RECOVERY

The heating capacity yielded and the input electrical capacity in conditions other than rated conditions are obtained by multiplying the rated values (Pt, Pa) by the respective correction coefficients (Cr, Ca).

Diagram (Tab. 8.14.1) allows you to obtain the correction coefficients; corresponding to each curve, the temperature of the hot processed water referred to is reported, assuming a difference in water temperature between the input and output of the condenser equal to 5°C.

KEY:

Cr = Heating capacity correction coefficient

Ca = Input power correction coefficient

8.15. FOR ΔT DIFFERENT FROM THE RATED VALUE

For Δt different from 5°C to the evaporator, refer to Tab.8.15.1 for the cooling capacity and input power correction factors.

8.16. FOULING FACTORS

The performance levels indicated in table 8.16.1 refer to conditions with clean tubes, with a fouling factor = 1. For values different from the fouling factor, multiply the values in the performance table by the reported coefficients.

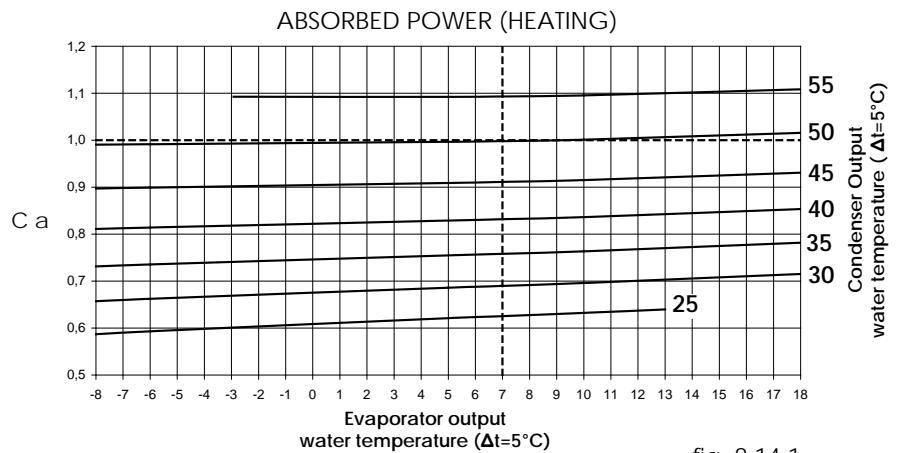
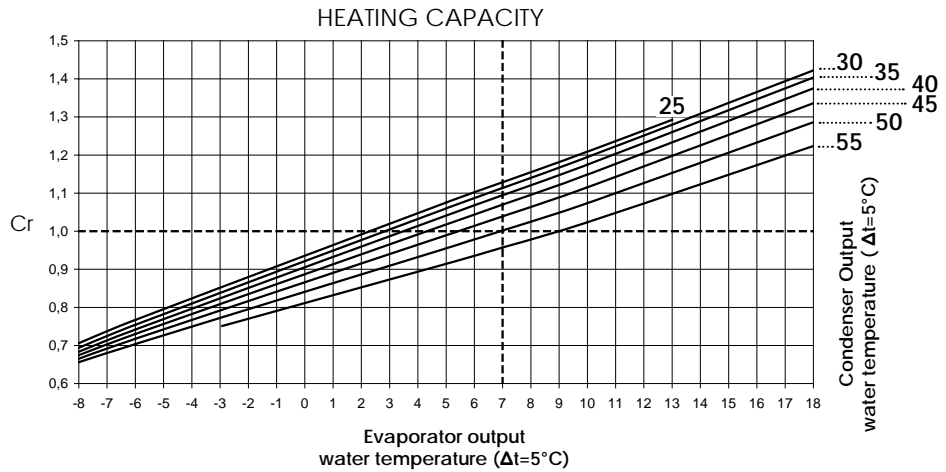

fig. 8.14.1

8.15.1 CORRECTION FACTORS FOR ΔT DIFFERENT FROM THE CHILLER RATED VALUE

Evaporator Δt different to nominal	3	5	8	10
Correction factor cooling capacity	0,99	1	1,02	1,03
Correction factor input power	0,99	1	1,01	1,02
Correction factor heating capacity	0,99	1	1,02	1,03
Condenser Δt different to nominal	3	5	8	10
Correction factor heating capacity	0,9912	1	1,013	1,0227
Correction factor input power	1,0144	1	0,978	0,9633

8.16.1 FOULING FACTOR

Fouling factor [K*m²]/[W]	0,00001	0,00002	0,00005
Correction factor cooling capacity	1	0,99	0,98
Correction factor input power	1	1	1
Correction factor heating capacity	1	1	0,99
Correction factor input power	1	1	1,02

8.17. PRESSURE DROPS TOTAL RECOVERY

The pressure drops in the charts refer to an average water temperature of 50 °C. The table (8.17.1) shows the corrections to apply to the pressure drops with a variation in average water temperature.

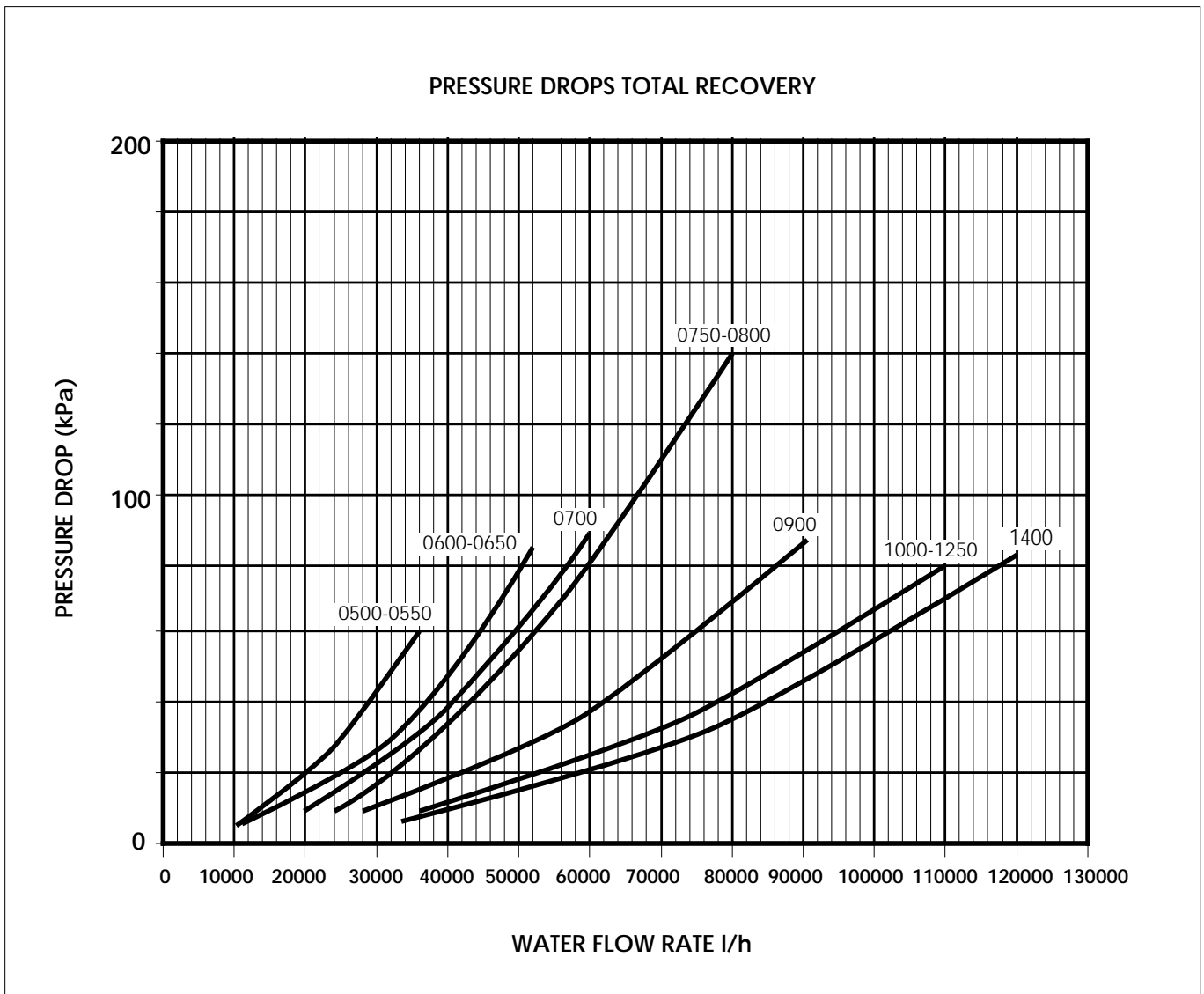

Average water temperature [°C]	5	10	15	20	30	40	50
Correction factor	1,22	1,10	1,08	1,06	1,04	1,02	1,00

Tab 8.17.1

9. TOTAL PRESSURE DROPS

9.1. EVAPORATOR IN COOLING OPERATION

The diagram pressure drops are related to an average water temperature of 10 °C.

Water flow rate (l/h) MIN e MAX

NXW			
Model	U.M.	Water flow rate MIN	Water flow rate MAX
0500-0800	l/h	7920	55800
0900-1400	l/h	16920	120600

ATTENTION

- Lower water flow speed might get some substance deposited in the heat exchanger
- Higher water flow speed might cause mechanical damages)

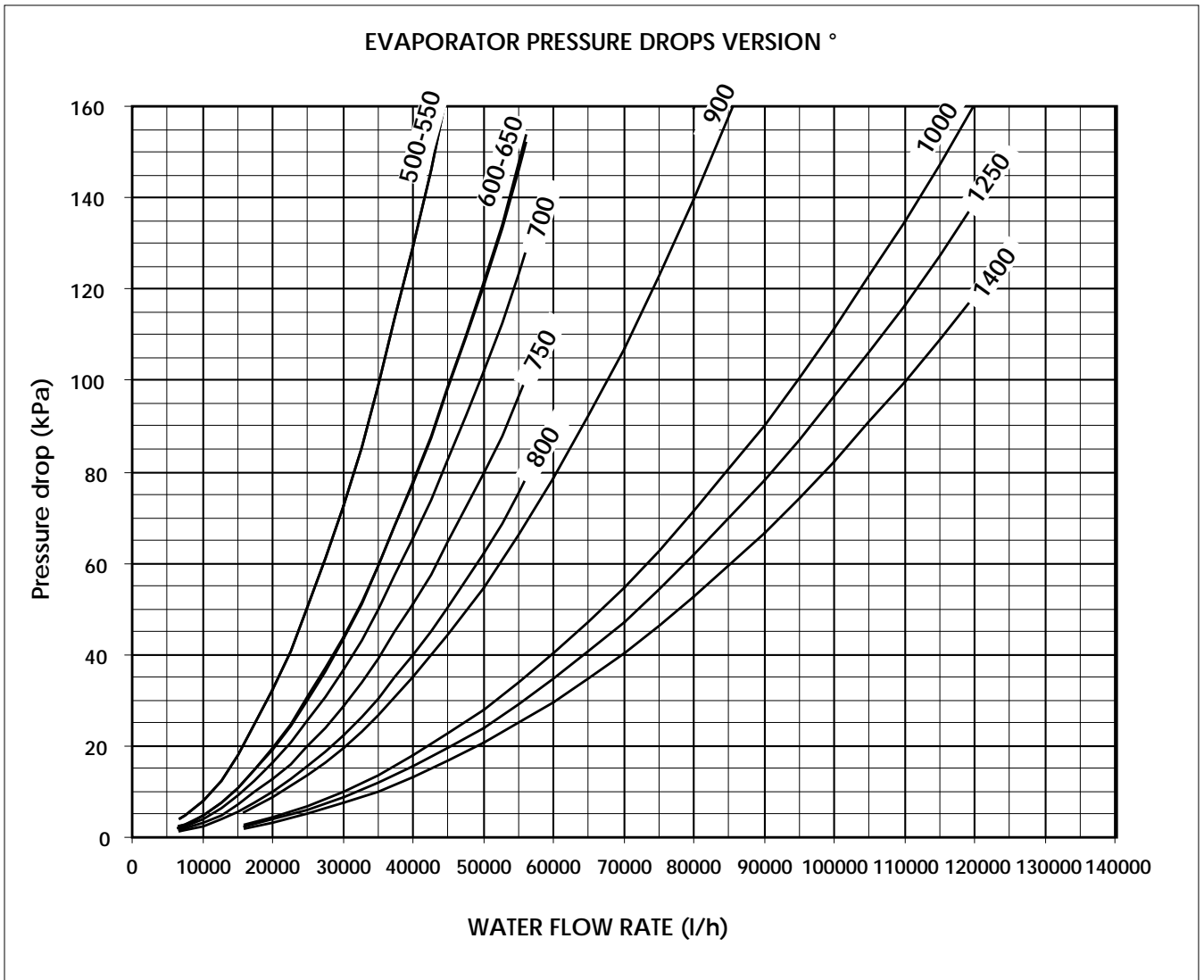

The correction to apply to the pressure drops when the average water temperature varies

EVAPORATOR							
Average water temperature °C	5	10	15	20	30	40	50
Correction factor	1,02	1	0,985	0,97	0,95	0,93	0,91

9.2. CONDENSER IN COOLING OPERATION

The diagram pressure drops are related to an average water temperature of 30 °C

Water flow rate (l/h) MIN e MAX

NXW			
Model	U.M.	Water flow rate MIN	Water flow rate MAX
0500-0800	l/h	7920	55800
0900-1400	l/h	16920	120600

ATTENTION

- Lower water flow speed might get some substance deposited in the heat exchanger
- Higher water flow speed might cause mechanical damages)

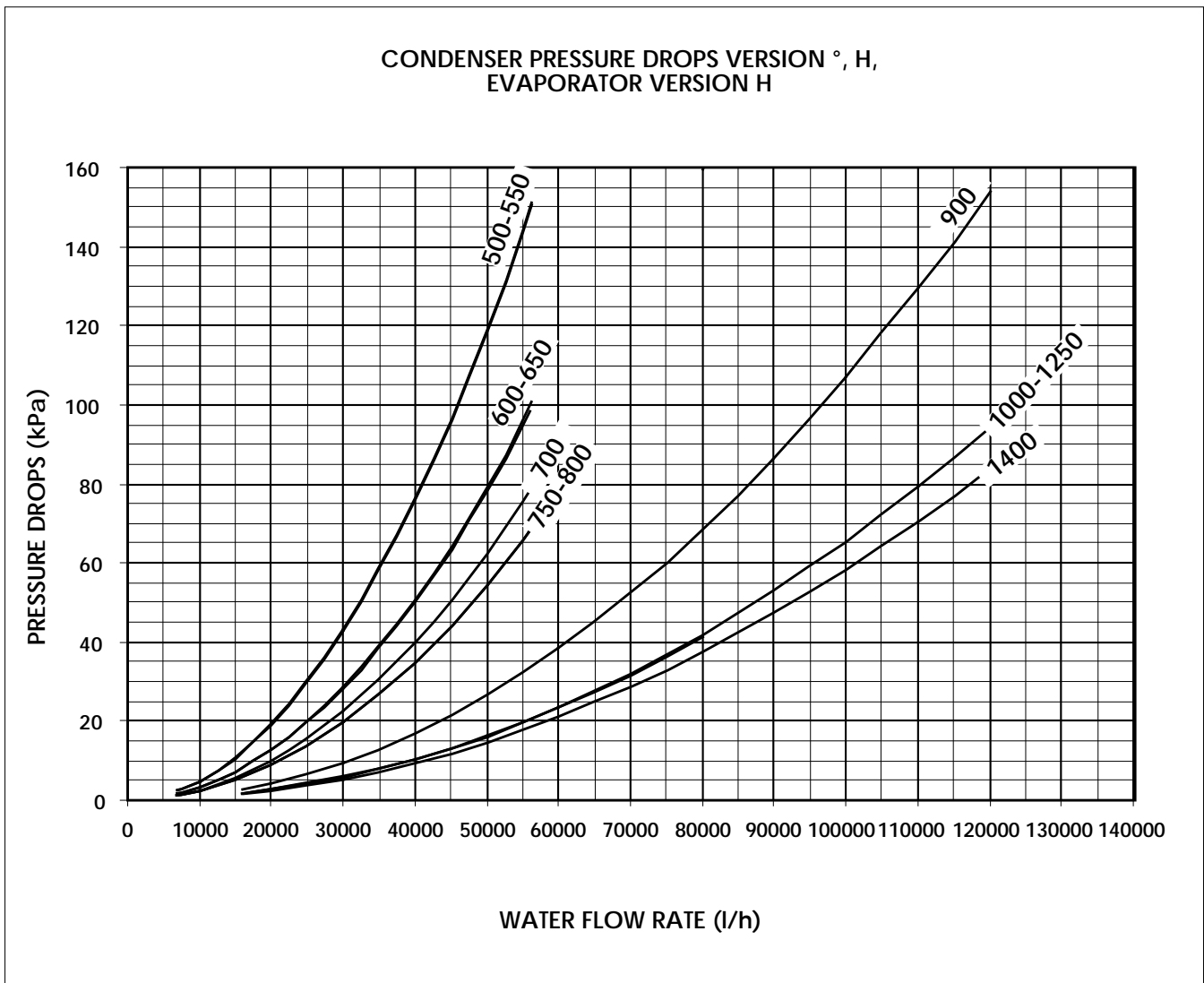

The correction to apply to the pressure drops when the average water temperature varies

CONDENSER								
Average water temperature °C	23	28	33	38	43	48	53	58
Correction factor	1,02	1,01	1,00	0,99	0,98	0,97	0,96	0,95

10. USEFUL HEADS

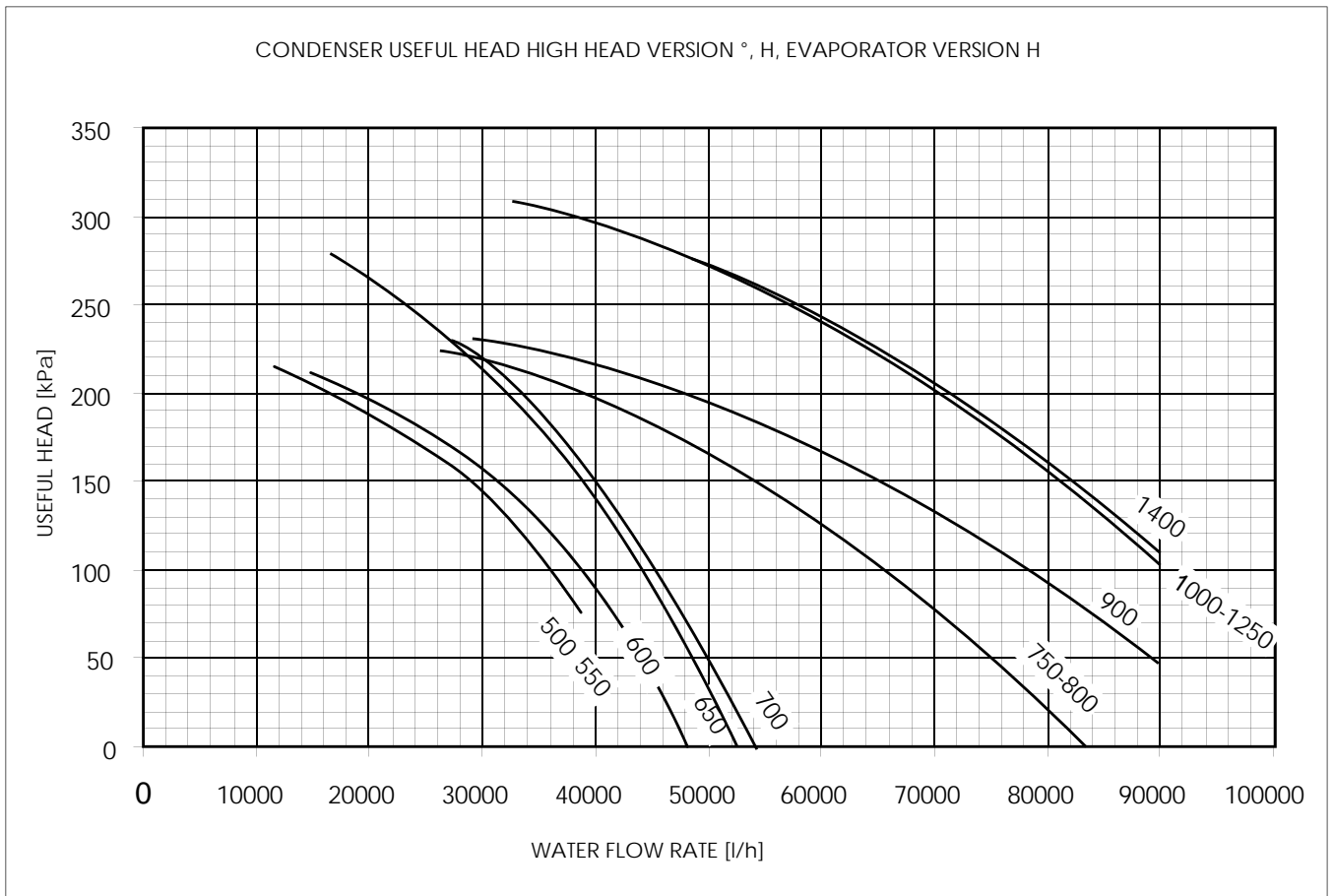
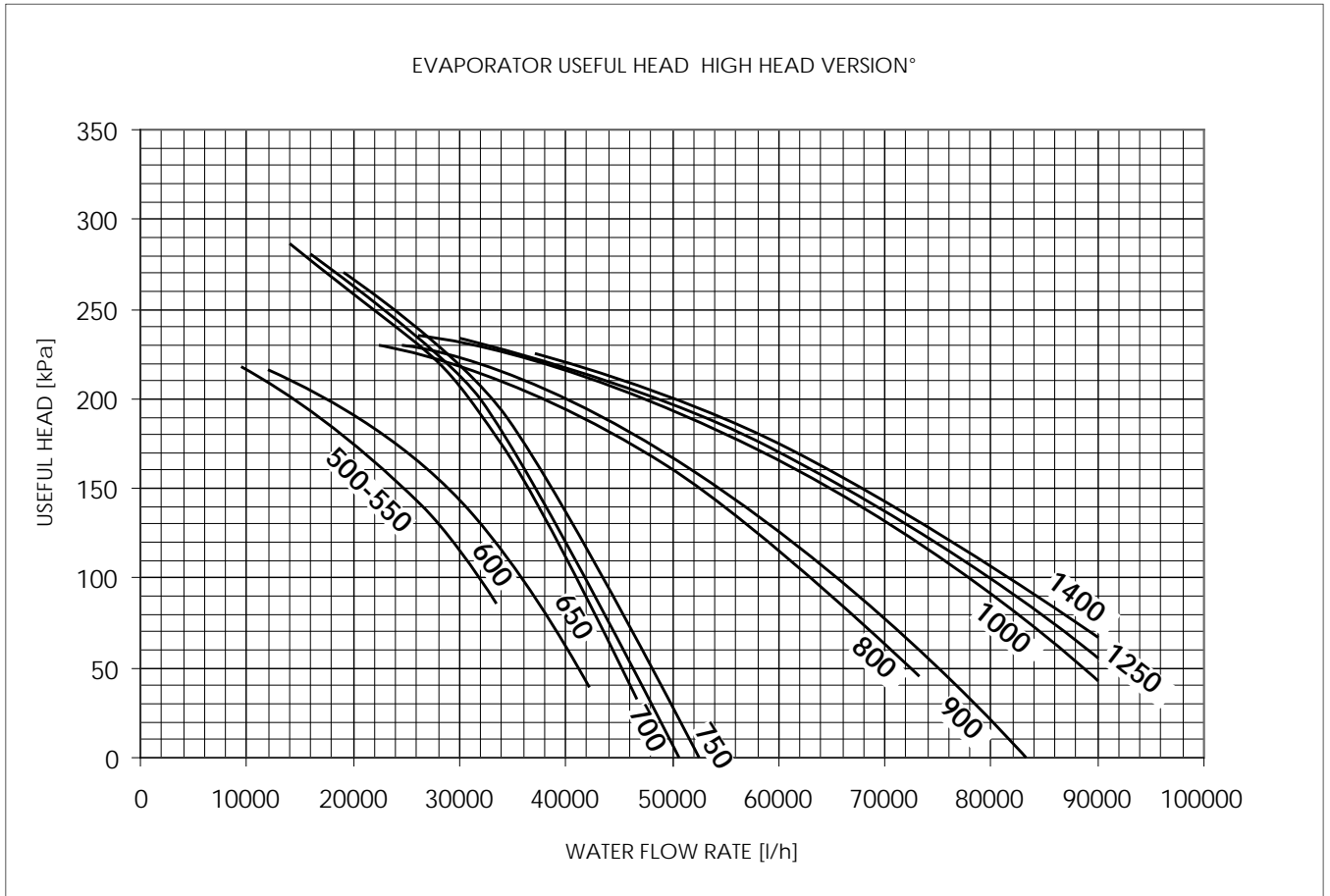

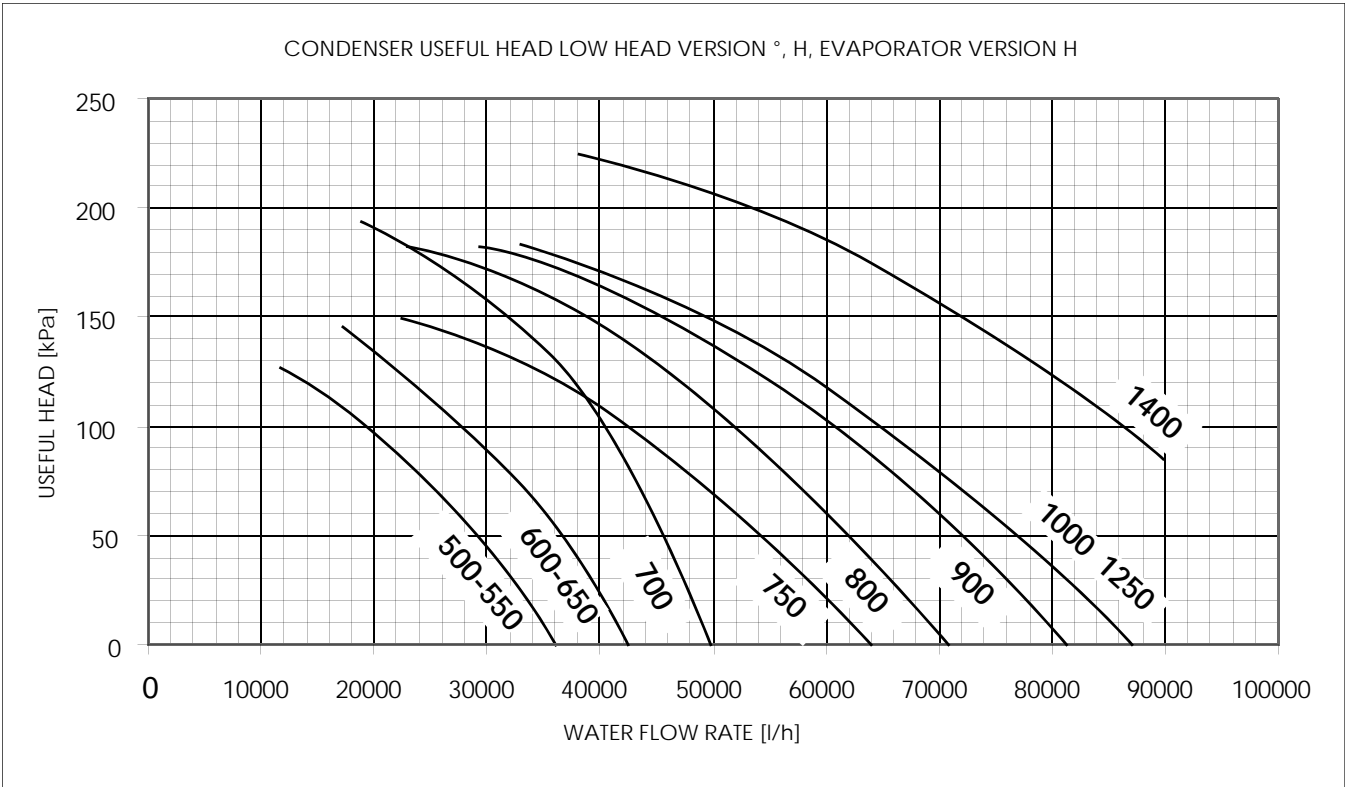
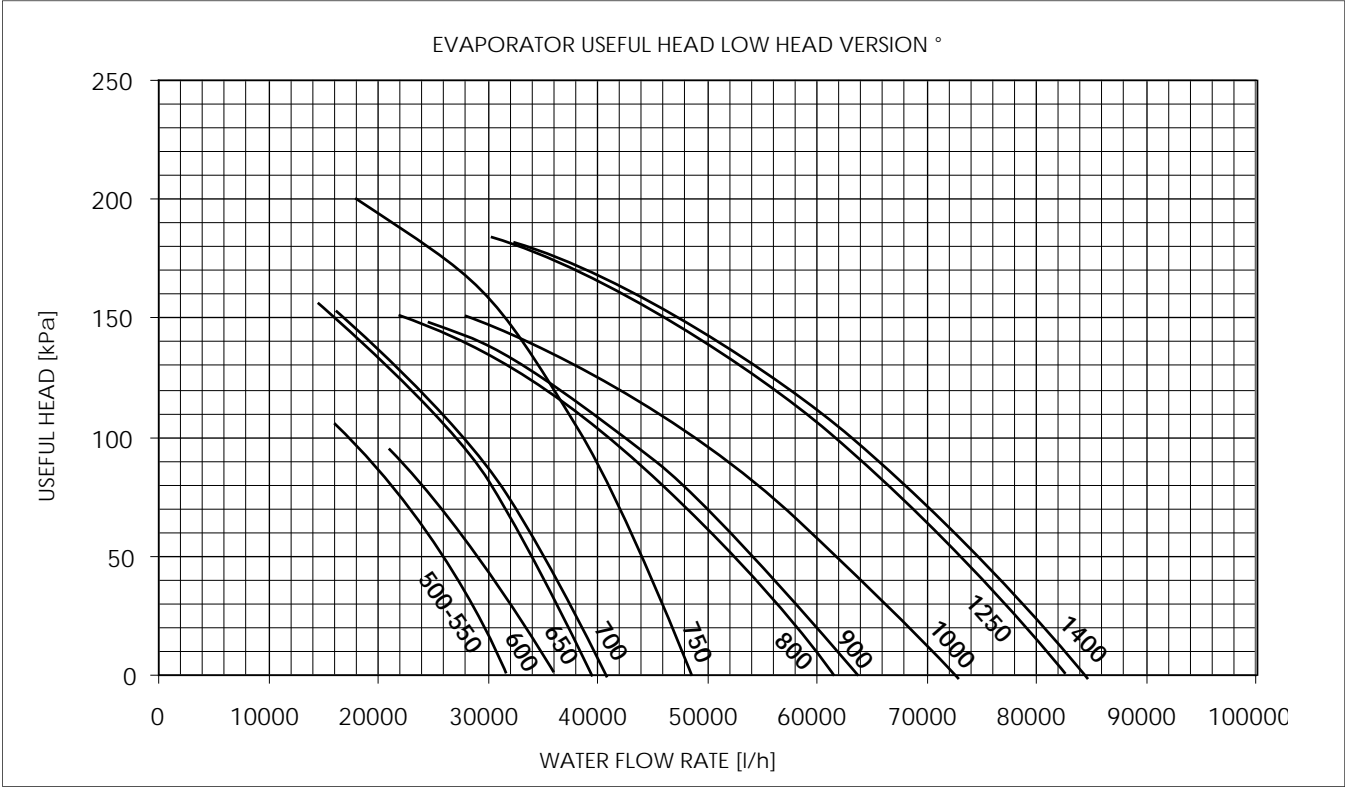

EVAPORATOR USEFUL HEAD HIGH HEAD VERSION H

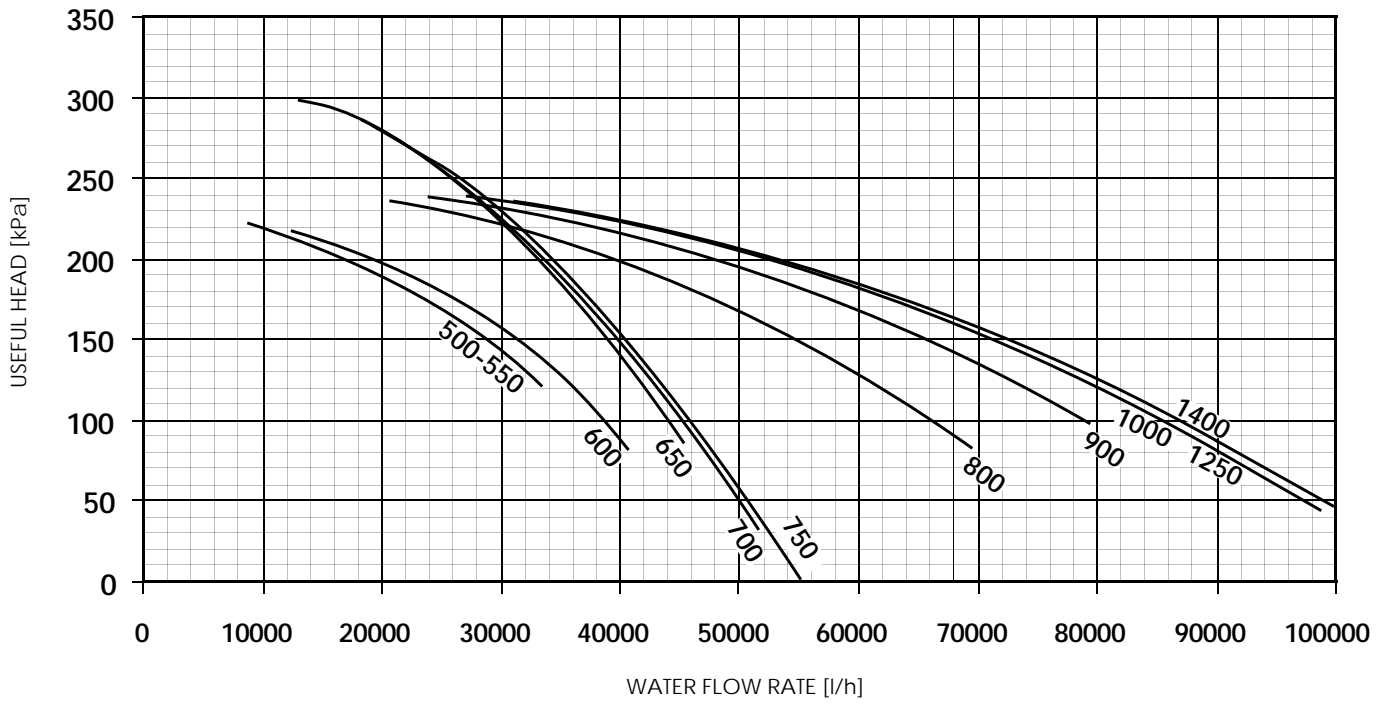

EVAPORATOR USEFUL HEAD LOW HEAD VERSION H

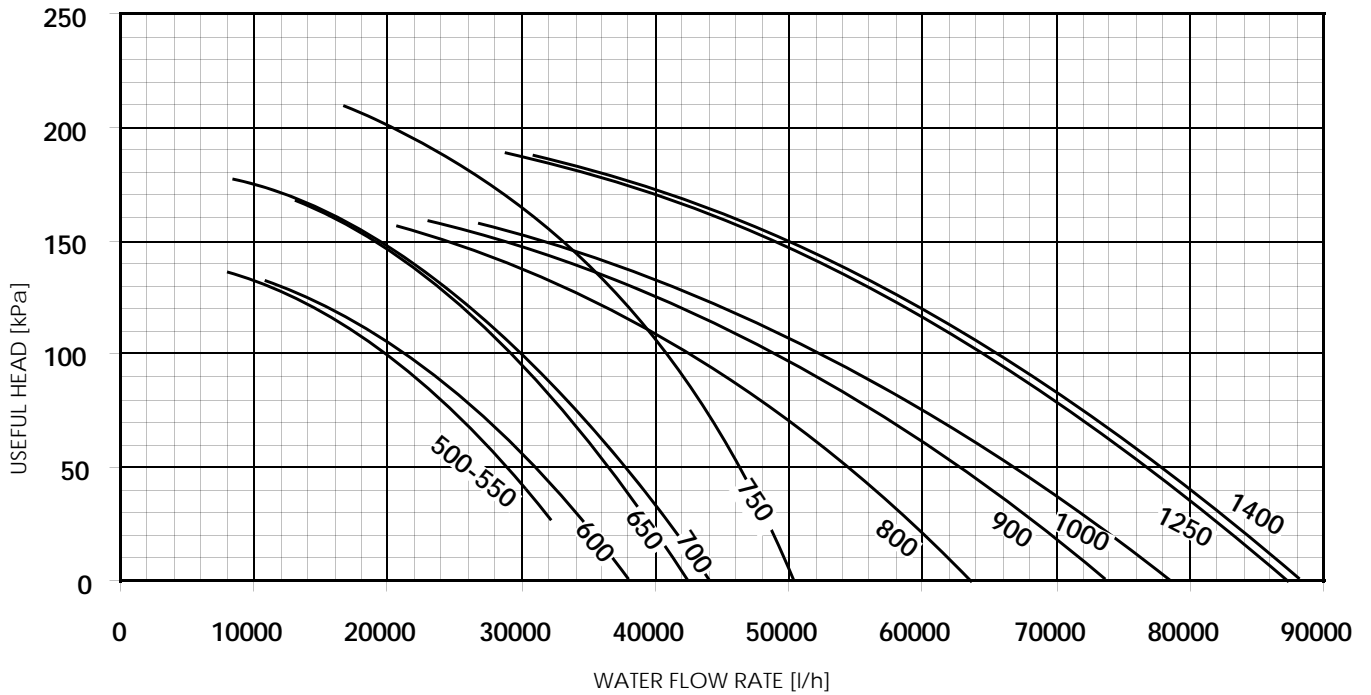

11. MINIMUM/MAXIMUM WATER CONTENT IN THE SYSTEM

Mod. NXW	vers	U.M.	0500	0550	0600	0650	0700	0750	0800	0900	1000	1250	1400
WATER CONTENT IN THE SYSTEM	tutte	I/kW(1)	5		4								
		I/kW(2)	10		8								

(1) Minimum water content

(2) Minimum water content in the case of process applications or applications with low load.

Δt Project data less than 5 ° C

12. EXPANSION TANK CALIBRATION

The standard pre-load pressure value of the expansion vessel is 1.5 bar, while their volume is 25 litres. The maximum value is 6 bar.

Vessel calibration must be regulated using the maximum level difference (H) of the user (see diagram) by using the following formula.

$$p \text{ (calibration) [bar]} = H \text{ [m]} / 10.2 + 0.3$$

For example: if level difference (H) is equal to 20m, the calibration value of the vessel will be 2.3 bar.

If the calibration value obtained from the calculation is less than 1.5 bar (i.e. for $H < 12.25$), keep standard calibration.

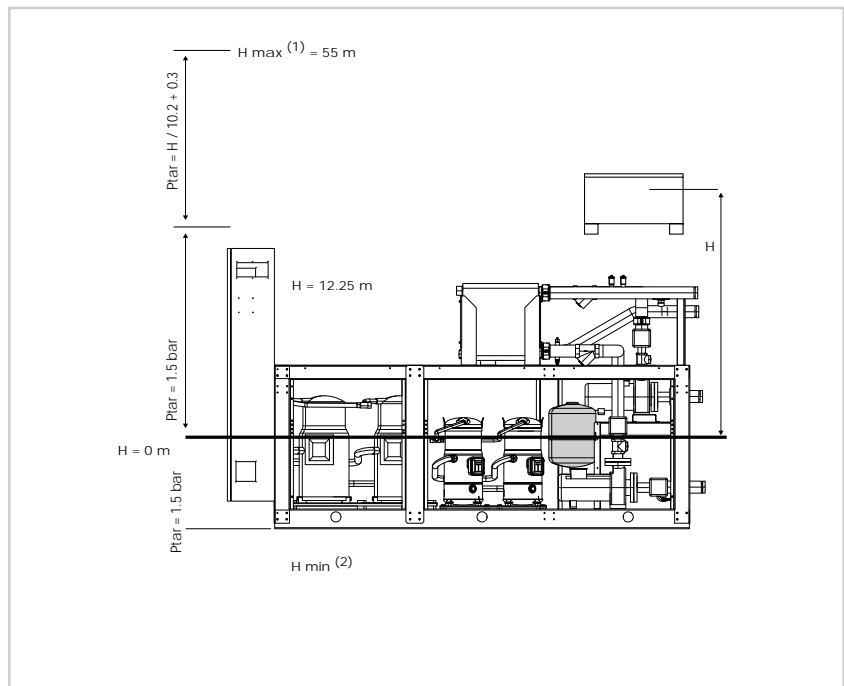

KEY

(1) Check that highest installation does not exceed a height difference of 55 metres.

(2) Ensure that lowest installation can withstand global pressure in that position

NXW						
Hydraulic height	H m	30	25	20	15	≥ 12.25
Calibration of the expansion vessel	bar	3.2	2.8	2.3	1.8	1.5
Water content reference value	l ⁽¹⁾	2.174	2.646	3.118	3590	3852
Water content reference value	l ⁽²⁾	978	1190	1404	1616	1732

13. GLYCOL

- The cooling capacity and input power correction factors make allowance for the presence of glycol and the different evaporation temperature.
- The pressure drop correction factor already takes into account the different flow rate deriving from the application of the water flow rate correction factor.
- The correction factor of the water flow rate is calculated so as to maintain the same Δt that would be used in the absence of glycol.

NB

An example is given to make it easier to read the following graph.

By using the diagram below it possible to establish the percentage of glycol necessary; this percentage can be calculated taking into account one of the following factors:

On the basis of the fluid considered (water or air), it will be necessary to enter the graph from the right or left side, from the intersection of the outside air temperature or processed water temperature straight lines and the relative curves, a point is obtained through which the vertical line that will identify both the percentage of glycol and the relative correction coefficients will have to pass.

13.1. HOW TO READ THE GLYCOL CURVES

The curves shown in the figure summarise a notable quantity of data, each of which is represented by a specific curve. In order to use these curves correctly, it is necessary to make some initial considerations:

- If you want to calculate the percentage of glycol on the basis of the outside air temperature, you must enter from the left-hand axis and, once you have intersected the curve, trace a vertical line which, in turn, will intercept all the other curves; the points obtained from the upper curves represent the coefficients for the correction of the cooling capacity and input power, for the flow rates and the pressure drops (remember that these coefficients must anyway be multiplied by the rated value of the sizes examined); the lower axis advises the percentage of glycol necessary on the basis of the outside air temperature considered. If you want to calculate the percentage of glycol

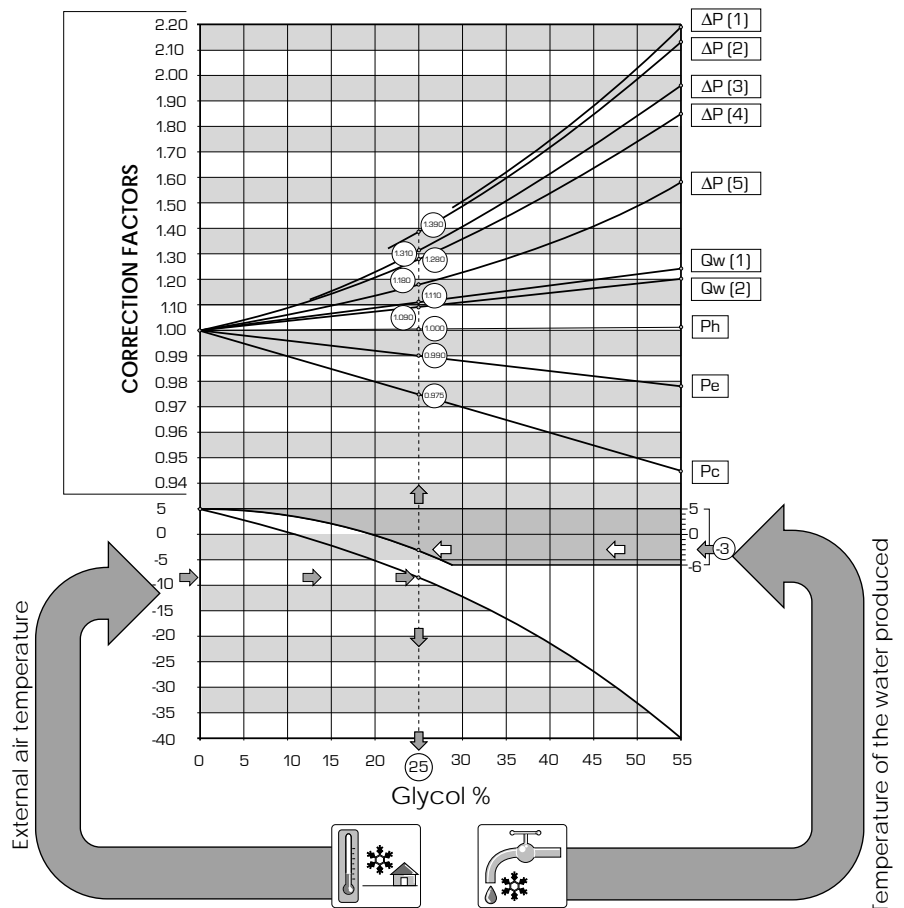

KEY:

- Pc Correction factor of the cooling capacity
- Pe Correction factor of the input power
- ΔP (1) Correction factor of the pressure drops average temp. = -3.5°C
- ΔP (2) Correction factor of the pressure drops average temp. = 0.5°C
- ΔP (3) Correction factor of the pressure drops average temp. = 5.5°C
- ΔP (4) Correction factor of the pressure drops average temp. = 9.5°C
- ΔP (5) Correction factor of the pressure drops average temp. = 47.5°C
- Qw (1) Correction factor of the outputs (evaporator) average temp. = 9.5°C
- Qw (2) Correction factor of the outputs (condenser) average temp. = 47.5°C

NB

Although the graph reaches outside air temperatures of -40°C, it is necessary to maintain the machine's operating limits as reference.

on the basis of the temperature of the processed water, you must enter from the right-hand axis and, once you have intersected the curve, trace a vertical line which, in turn, will intercept all the other curves; the points obtained from the upper curves represent the coefficients for the cooling capacity and input power, for the flow rates and the pressure drops (remember that these coefficients must anyway be multiplied by the rated value of the sizes examined); the lower axis advises the percentage of glycol necessary to produce water at the

required temperature.

- Remember that the initial sizes "OUTSIDE AIR TEMPERATURE" and "PROCESSED WATER TEMPERATURE", are not directly linked to each other, so it is not possible to enter the curve of one of these sizes, and obtain the corresponding point on the other curve.

14. COOLING LINES

Model	Line length [m]	Delivery line [mm]		Liquid line [mm]		Refrigerant R410A per metre of line [g/m]	Refrigerant R410A per metre of line [g/m]
		C1	C2	C1	C2	C1	C2
NXW0500E	0-10	28	22	28	22	610	380
	10-20	28	22	28	22	610	380
	20-30	28	22	28	22	610	380
NXW0550E	0-10	28	22	28	22	610	380
	10-20	28	22	28	22	610	380
	20-30	28	22	28	22	610	380
NXW0600E	0-10	28	28	28	28	610	610
	10-20	28	28	28	28	610	610
	20-30	28	28	28	28	610	610
NXW0650E	0-10	28	28	28	28	610	610
	10-20	28	28	28	28	610	610
	20-30	28	28	28	28	610	610
NXW0700E	0-10	28	28	28	28	610	610
	10-20	28	28	28	28	610	610
	20-30	28	28	28	28	610	610
NXW0750E	0-10	28	28	28	28	610	610
	10-20	35	28	28	28	640	610
	20-30	35	28	28	28	640	610
NXW0800E	0-10	28	28	28	28	610	610
	10-20	35	35	28	28	640	640
	20-30	35	35	28	28	640	640
NXW0900E	0-10	35	35	28	28	640	640
	10-20	35	35	28	28	640	640
	20-30	35	35	28	28	640	640
NXW1000E	0-10	35	35	35	35	950	950
	10-20	35	35	35	35	950	950
	20-30	35	35	35	35	950	950
NXW1250E	0-10	35	35	35	35	950	950
	10-20	35	35	35	35	950	950
	20-30	35	35	35	35	950	950
NXW1400E	0-10	42	42	35	35	990	990
	10-20	42	42	35	35	990	990
	20-30	42	42	35	35	990	990

Tcond = 45°C

Tevap = 4°C

Key

C1 = Cooling circuit 1

C2 = Cooling circuit 2

NXW - COOLING LINES

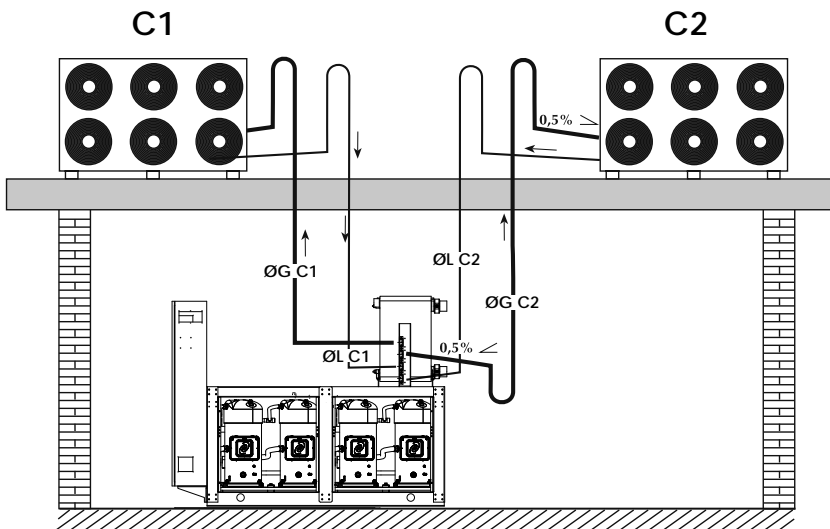

L = Linea liquido • Liquide line • Ligne liquide
 Flüssigkeitsleitung • Línea líquido
 G = Linea Gas • Gas Line • Ligne gaz •
 Gasleitung • Línea gas

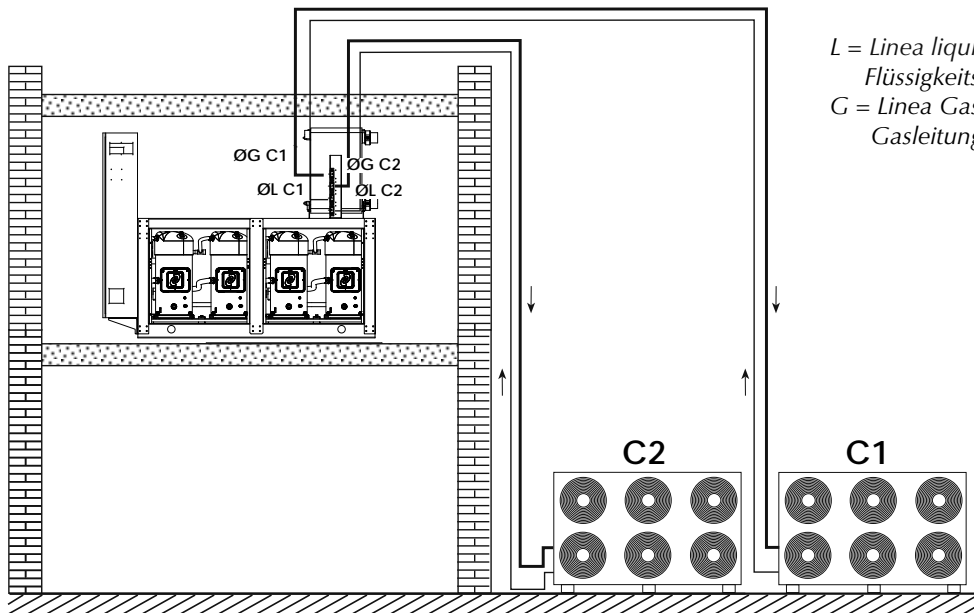

L = Linea liquido • Liquide line • Ligne liquide
 Flüssigkeitsleitung • Línea líquido
 G = Linea Gas • Gas Line • Ligne gaz •
 Gasleitung • Línea gas

For further information, (max. difference of level between evaporating and condensing unit etc.), contact us.

15. SOUND DATA

15.1. SOUND LEVELS OF STANDARD NXW VERSION «°»

Sound power

Aermec determines the sound power value on the basis of measurements taken in accordance with standard 9614-2, in compliance with the Eurovent certification.

Sound pressure

Sound pressure in free field, on a reflecting plane (directional factor Q=2), in accordance with standard ISO 3744.

The rated value refers to:

Evaporator water temperature 12/7 °C

Condenser air temperature 35 °C

Δt 5 °C

NXW [°]	Power dB(A)	Pressure dB(A)		Sound power by central band frequency [dB] (A)							
		10m	1m	125	250	500	1000	2000	4000	8000	
0500°	78	46	61	49.5	57.4	71.9	75.3	71.7	65.2	53.5	
0550°	79	47	62	50.5	57.7	72.4	76.3	72.4	65.8	54.2	
0600°	79	47	62	50.5	57.7	72.4	76.3	72.4	65.8	54.2	
0650°	80	48	63	50.9	58.8	73.4	77.5	73.2	66.4	54.2	
0700°	82	50	65	52.9	60.8	75.4	79.5	75.2	68.4	56.2	
0750°	86	54	69	57.1	65.1	79.5	83.5	79.1	72.3	60.2	
0800°	88	56	71	59.7	67.6	81.5	85.5	80.4	74.0	62.2	
0900°	88	56	71	59.7	67.6	81.5	85.5	80.4	74.0	62.2	
1000°	88	56	71	59.7	67.6	81.5	85.5	80.4	74.0	62.2	
1250°	90	58	73	61.7	69.6	83.5	87.5	82.4	76.0	64.2	
1400°	90	58	73	61.7	69.6	83.5	87.5	82.4	76.0	64.2	

15.2. SOUND LEVELS OF STANDARD SILENCED VERSION «L»

NXW [L]	Power dB(A)	Pressure dB(A)		Sound power by central band frequency [dB] (A)							
		10m	1m	125	250	500	1000	2000	4000	8000	
0500L	72	40	55	48.6	53.5	67.5	69.6	60.8	55.6	39.4	
0550L	73	41	56	49.6	53.8	68.0	70.6	61.5	56.2	40.1	
0600L	73	41	56	49.6	53.8	68.0	70.6	61.5	56.2	40.1	
0650L	74	42	57	50.0	54.9	69.0	71.8	62.3	56.8	40.1	
0700L	76	44	59	52.0	56.9	71.0	73.8	64.3	58.8	42.1	
0750L	80	48	63	56.2	61.2	75.1	77.8	68.2	62.7	46.1	
0800L	82	50	65	58.8	63.7	77.1	79.8	69.5	64.4	48.1	
0900L	82	50	65	58.8	63.7	77.1	79.8	69.5	64.4	48.1	
1000L	82	50	65	58.8	63.7	77.1	79.8	69.5	64.4	48.1	
1250L	84	52	67	60.8	65.7	79.1	81.8	71.5	66.4	50.1	
1400L	84	52	67	60.8	65.7	79.1	81.8	71.5	66.4	50.1	

NXW 0500-0750 version with pumps add 2dB

NXW 0800-1400 version with pumps add 3dB

16. SAFETY AND CHECK PARAMETER SETTING

CHECK PARAMETERS							
Cooling set	Water inlet temperature in cooling mode	MIN.	4°C				
		MAX.	15°C				
		DEFAULT	7.0°C				
Heating setting	Water inlet temperature in heating mode	MIN.	30°C				
		MAX.	50°C				
		DEFAULT	50°C				
Antifreeze intervention	Antifreeze alarm intervention temperature on EV side (water output temperature).	MIN.	-9°C				
		MAX.	4°C				
		DEFAULT	3°C				
Total differential	Proportional temperature band within which the compressors are activated and deactivated	MIN.	3°C				
		MAX.	10°C				
		DEFAULT	5°C				
Autostart	Auto						
COMPRESSOR THERMOMAGNETIC SWITCHES 400V							
Compressors							
MTC1 (CP1-CP1A)	A	22 - 22	22 - 28	28 - 28	28 - 28	33 - 33	43 - 43
MTC2 (CP2-CP2A)	A	33	33	22 - 22	28 - 28	33 - 33	33 - 33
Compressors							
MTC1 (CP1-CP1A)	A	43 - 43	53 - 43	53 - 53	57 - 53	57 - 57	
MTC2 (CP2-CP2A)	A	43 - 43	53 - 43	53 - 53	57 - 53	57 - 57	
MAIN SWITCH (without pumps)							
IG	A	80	100	100	125	160	160
MAIN SWITCH (without pumps)							
IG	A	200	200	250	250	250	
MAIN SWITCH (with pumps)							
IG	A	100	100	125	125	160	160
MAIN SWITCH (with pumps)							
IG	A	200	200	250	250	250	
TRANSDUCERS AND PRESSURE SWITCHES (manual reset)							
Pressure switch high press. (HP)	bar	40	40	40	40	40	40
High pressure transducer (THP)	bar	39	39	39	39	39	39
Low pressure transducer (TLP)	bar	1.6	1.6	1.6	1.6	1.6	1.6
Compressors							
Pressure switch high press. (HP)	bar	40	40	40	40	40	
High pressure transducer (THP)	bar	39	39	39	39	39	
Low pressure transducer (TLP)	bar	1.6	1.6	1.6	1.6	1.6	
COOLING CIRCUIT SAFETY							
High-pressure valve	bar	45	45	45	45	45	45
COOLING CIRCUIT SAFETY							
High-pressure valve	bar	45	45	45	45	45	

17. CAPACITY CONTROL

Capacity step control (cold)

* Cooling capacity %	Levels of power			
Versions	1°	2°	3°	4°
NXW0500	39	55	100	-
NXW0550	36	70	100	-
NXW0600	28	53	78	100
NXW0650	28	53	78	100
NXW0700	28	53	78	100
NXW0750	28	53	78	100
NXW0800	28	53	78	100
NXW0900	28	53	78	100
NXW1000	28	53	78	100
NXW1250	28	53	78	100
NXW1400	28	53	78	100

* Input power %	Levels of power			
Versions	1°	2°	3°	4°
NXW0500	33	49	100	-
NXW0550	30	64	100	-
NXW0600	22	47	72	100
NXW0650	22	47	72	100
NXW0700	22	47	72	100
NXW0750	22	47	72	100
NXW0800	22	47	72	100
NXW0900	22	47	72	100
NXW1000	22	47	72	100
NXW1250	22	47	72	100
NXW1400	22	47	72	100

Performance values refer to the following conditions:

- * Evaporator inlet water temperature = 7°C
- condenser inlet water temperature = 35°C

Capacity step control (hot)

* Heating capacity %	Levels of power			
Versions	1°	2°	3°	4°
NXW0500	38	54	100	--
NXW0550	35	69	100	
NXW0600	27	52	77	100
NXW0650	27	52	77	100
NXW0700	27	52	77	100
NXW0750	27	52	77	100
NXW0800	27	52	77	100
NXW0900	27	52	77	100
NXW1000	27	52	77	100
NXW1250	27	52	77	100
NXW1400	27	52	77	100

* Input power %	Levels of power			
Versions	1°	2°	3°	4°
NXW0500	33	49	100	-
NXW0550	30	64	100	-
NXW0600	22	47	72	100
NXW0650	22	47	72	100
NXW0700	22	47	72	100
NXW0750	22	47	72	100
NXW0800	22	47	72	100
NXW0900	22	47	72	100
NXW1000	22	47	72	100
NXW1250	22	47	72	100
NXW1400	22	47	72	100

Performance values refer to the following conditions:

** Evaporator inlet water temperature = 5°C;
condenser inlet water temperature = 45°C;

FOR THE INSTALLER

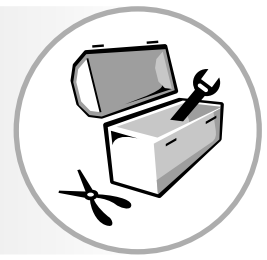

18. SELECTION AND PLACE OF INSTALLATION

Before installing the unit, decide with the customer the position in which it will be placed, pay attention to the following points:

- the support surface must be able to withstand the weight of the unit;
- The NXW series are for indoor use (protection grade IP40) and must be installed leaving the necessary technical spaces (see "Minimum technical spaces"). Observance of these spaces is to be considered indispensable in order to allow normal and extraordinary maintenance operations.
- The unit must be installed by a qualified technician in accordance with the national laws in force in the country of installation.

19. POSITIONING

The machine is delivered from the fac-

tory wrapped in estincoil.

Before moving the unit, check the lifting capacity of the machines used.

Once the packaging has been removed, the unit must be handled by qualified personnel with the suitable equipment. To transport the machine use either a forklift or lifting belts (see figure)

- The holes in the base to be used for lifting are indicated with yellow adhesives showing a black arrow. The blades (not included) which are adequately scaled must protrude from the base unit for a sufficient length so that the lifting straps can be tightened upwards without them encountering any interference.
- Make sure that the straps have been approved to support the weight of the unit, be careful that they are properly fixed to the upper frame and to the lifting blades, the safety closure must ensure that the

straps do not work loose of their housing. The hooking point of the lifting frame must be on the vertical of the centre of gravity (see transport figure).

- In order to avoid damaging the unit with the cables, insert protection elements between them and the machine. It is absolutely forbidden to stand beneath the unit.
- Take into account that when the chiller is working, vibrations may be generated; it is therefore advisable to install anti-vibration supports (AVX accessories), fitting them to the holes in the base according to the assembly diagram.
- Fasten the unit by checking carefully that it is on the same level; check that easy access to the hydraulic and electric part is allowed.

19.1. MINIMUM TECHNICAL SPACES (mm)

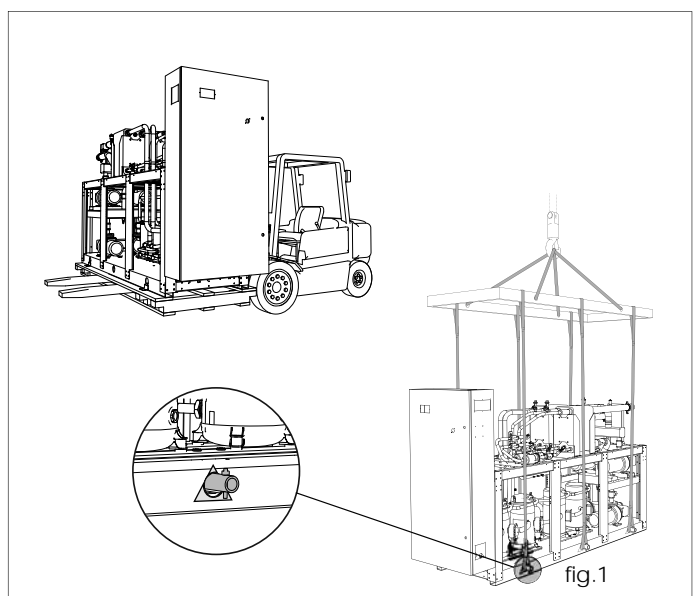
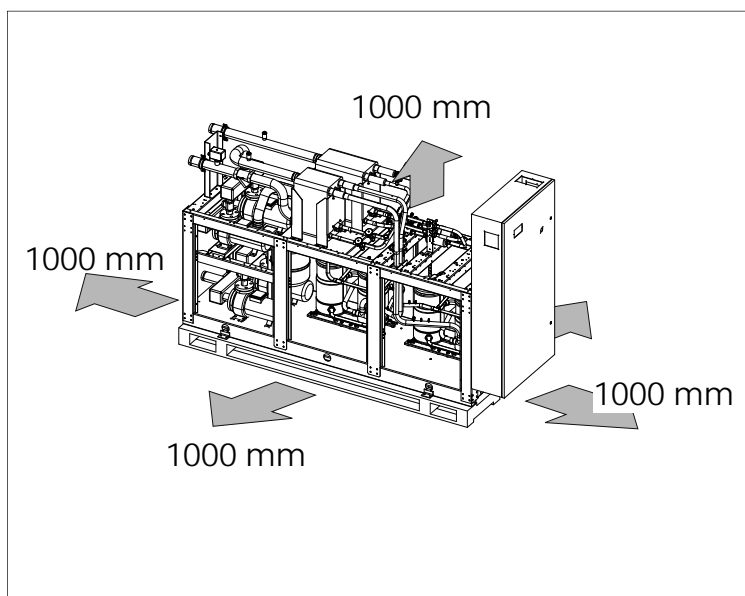

ATTENTION
Use all of the available holes for lifting
The blades not included

20. DIMENSIONAL TABLES

NXW 0500/0700 STANDARD VERSION

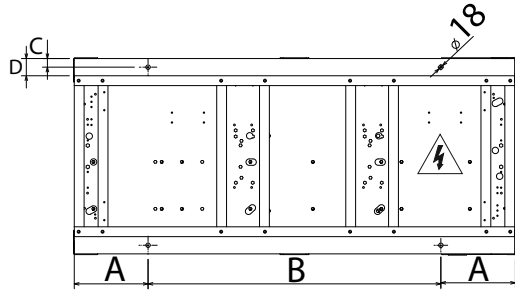

		AVX				
Model	U.M.	0500	0550	0600	0650	0700
A	mm	300	300	300	300	300
B		1190	1190	1190	1190	1190
C		35	35	35	35	35
D		70	70	70	70	70

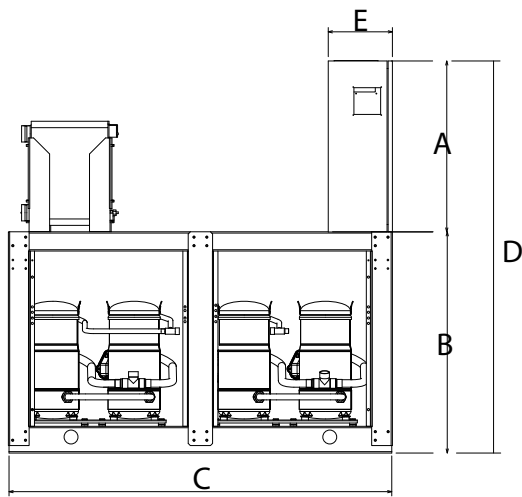

VERSION ° HEAT PUMP WITH WATER SIDE INVERSION

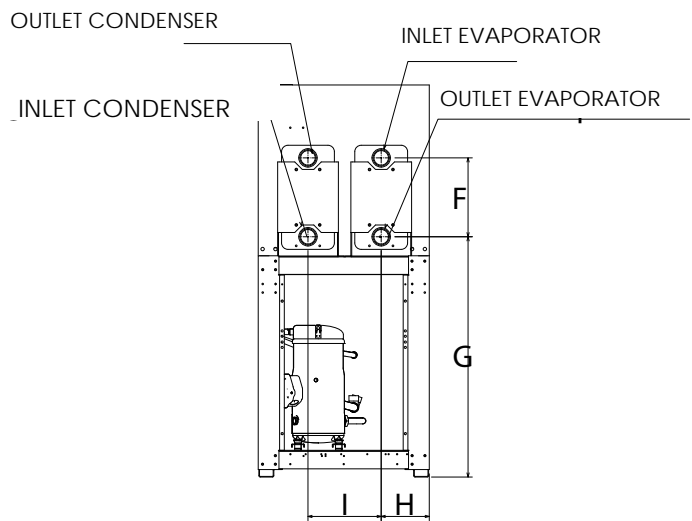

VERSION H HEAT PUMP WITH GAS SIDE CYCLE INVERSION - COOLING MODE

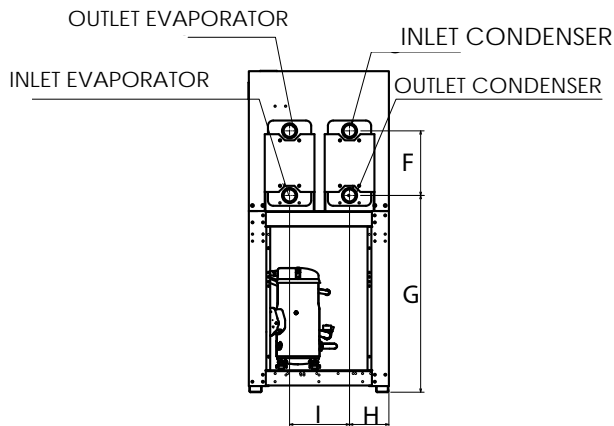

		POSITION				
Model	U.M.	0500	0550	0600	0650	0700
A	mm	800	800	800	800	800
B		1035	1035	1035	1035	1035
C		1790	1790	1790	1790	1790
D		1835	1835	1835	1835	1835
E		300	300	300	300	300
F		369	369	369	369	369
G		1125	1125	1125	1125	1125
H		225	225	225	225	225
I		343	343	343	343	343

Model	U.M.	0500	0550	0600	0650	0700
EVAPORATOR (PLATES)						
Hydraulic connection Victaulic IN/OUT	Ø	2"1/2	2"1/2	2"1/2	2"1/2	2"1/2
CONDENSER (PLATES)						
Hydraulic connection Victaulic IN/OUT	Ø	2"1/2	2"1/2	2"1/2	2"1/2	2"1/2

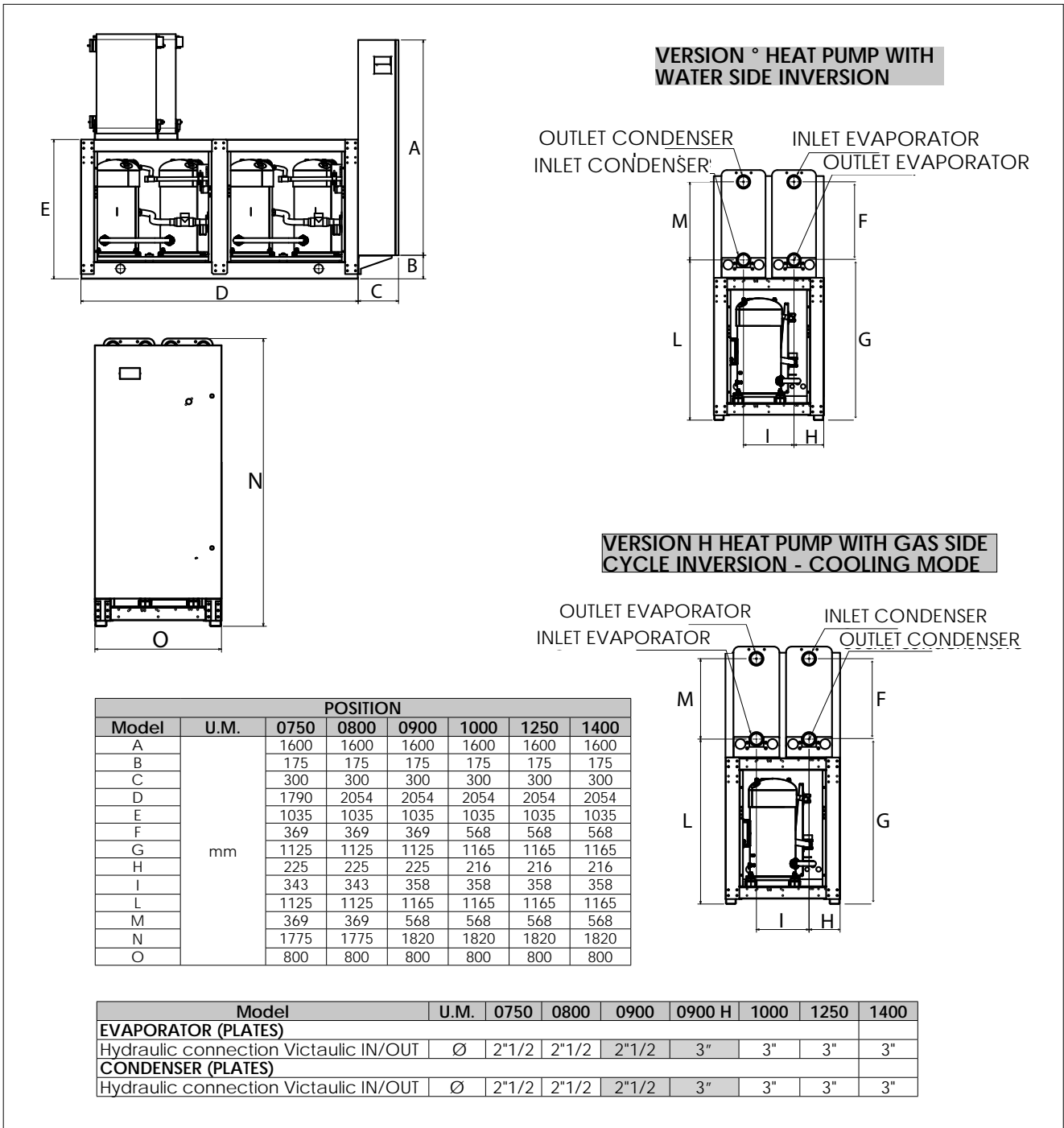
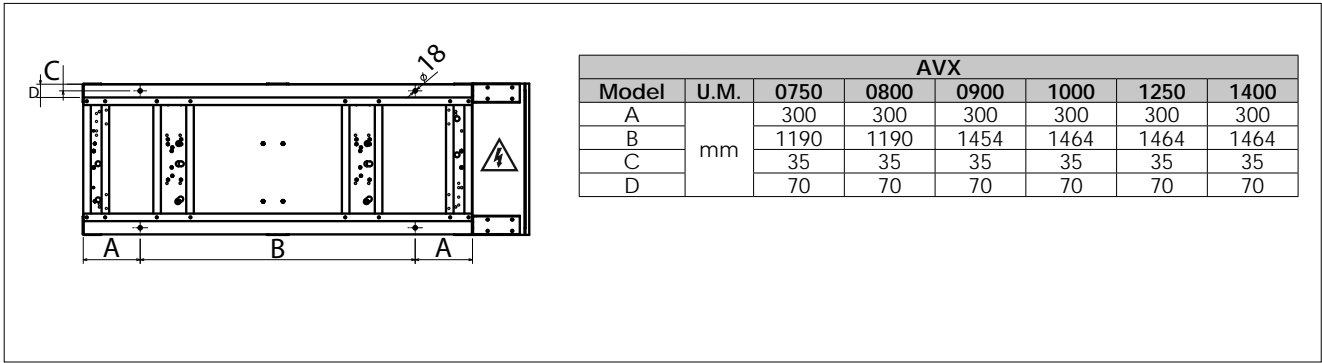

NXW FROM 0500 TO 1400 VERSION WITH PUMP

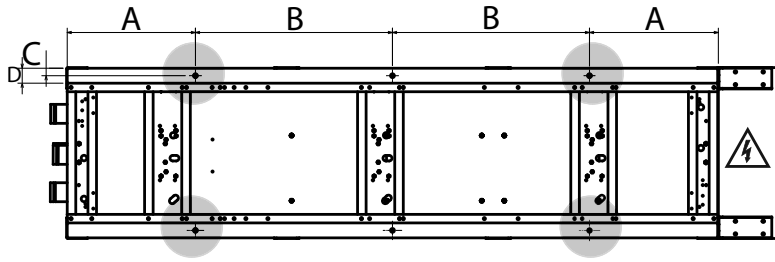

AVX												
Model	U.M.	0500	0550	0600	0650	0700	0750	0800	0900	1000	1250	1400
A	mm	390	390	390	390	390	390	600	600	600	600	600
B		932	932	932	932	932	932	922	922	922	922	922
C		390	390	390	390	390	390	600	600	600	600	600
D		35	35	35	35	35	35	35	35	35	35	35
E		70	70	70	70	70	70	70	70	70	70	70

VERSION ° HEAT PUMP WITH WATER SIDE INVERSION

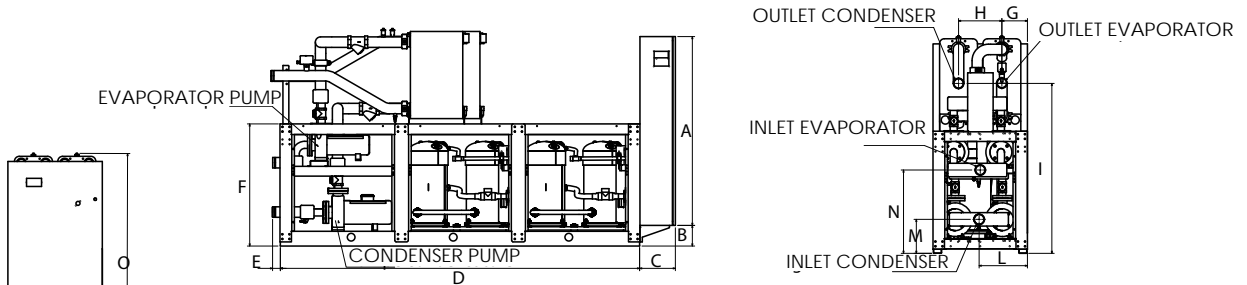

VERSION H HEAT PUMP WITH GAS SIDE CYCLE INVERSION - COOLING MODE

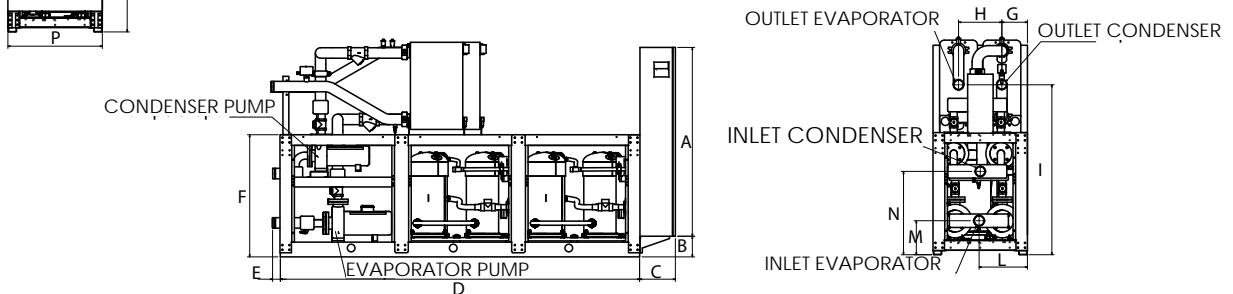

POSITION												
Model	U.M.	0500	0550	0600	0650	0700	0750	0800	0900	1000	1250	1400
A	mm	1600	1600	1600	1600	1600	1600	1600	1600	1600	1600	1600
B		175	175	175	175	175	175	175	175	175	175	175
C		300	300	300	300	300	300	300	300	300	300	300
D		2644	2644	2644	2644	2644	2644	2644	3044	3044	3044	3044
E		75	75	75	75	75	75	75	75	75	75	75
F		1035	1035	1035	1035	1035	1035	1035	1035	1035	1035	1035
G		225	225	225	225	225	225	225	225	216	216	216
H		343	343	343	343	343	343	343	357	367	367	367
I		1374	1374	1374	1374	1374	1374	1374	1374	1440	1440	1440
L		410	410	410	410	410	410	422	425	410	410	410
M		264	264	264	264	264	264	260	260	288	288	288
N		838	838	838	838	838	838	858	858	706	706	706
O		1775	1775	1775	1775	1775	1775	1775	1850	1850	1850	1850
P		800	800	800	800	800	800	800	800	800	800	800

Model	U.M.	0500	0550	0600	0650	0700	0750	0800	0900	0900 H	1000	1250	1400
EVAPORATOR (PLATES)													
Hydraulic connection		Ø	2"1/2	2"1/2	2"1/2	2"1/2	2"1/2	2"1/2	2"1/2	2"1/2	3"	3"	3"
Victaulic in/out													
CONDENSER (PLATES)													
Hydraulic connection		Ø	2"1/2	2"1/2	2"1/2	2"1/2	2"1/2	2"1/2	2"1/2	2"1/2	3"	3"	3"
Victaulic in/out													

NXW LOW NOISE VERSION

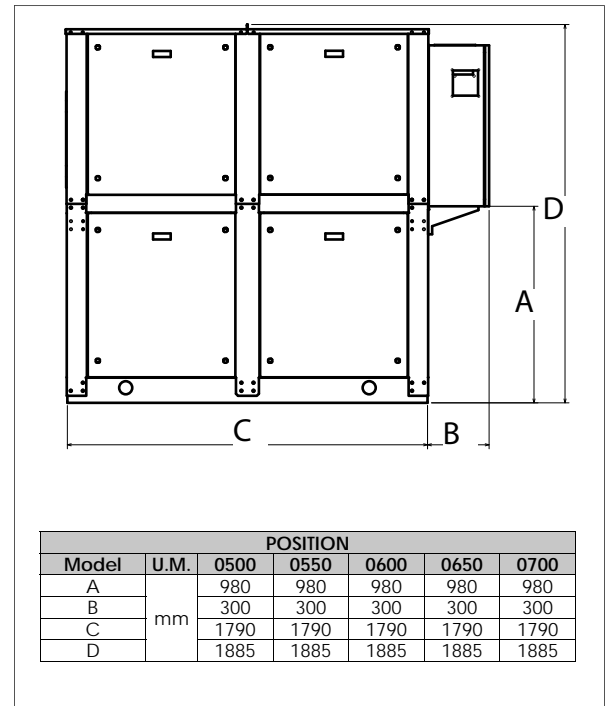
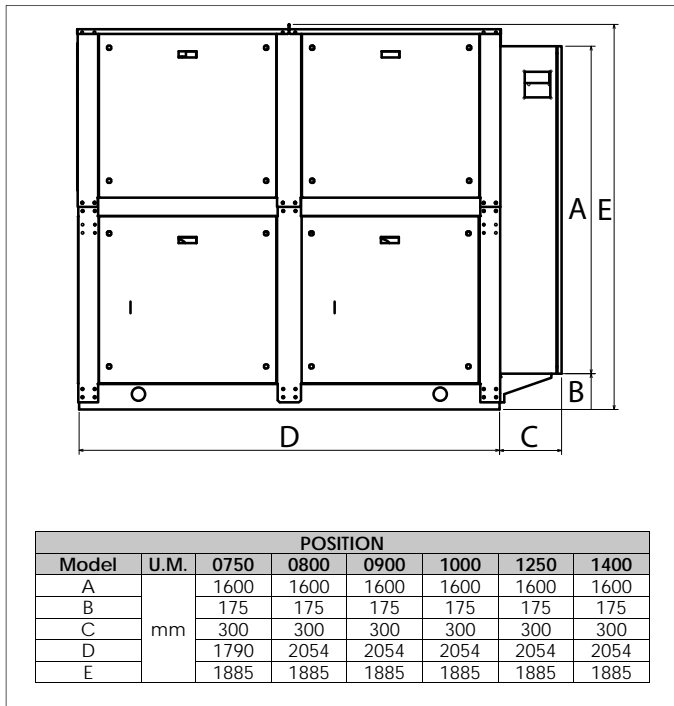

NXW 0500/0700 VERSION TOTALE RECOVERY(T)

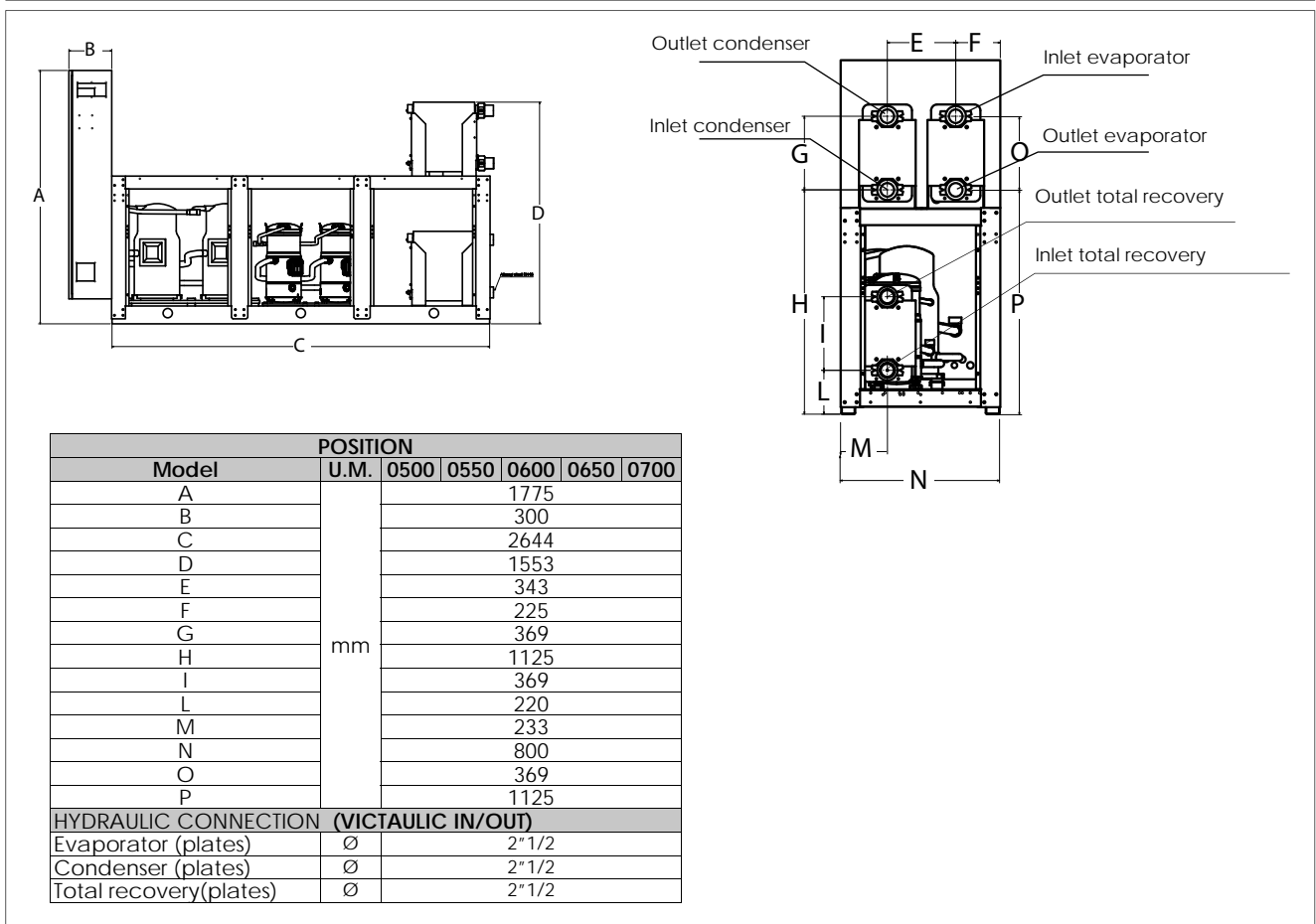
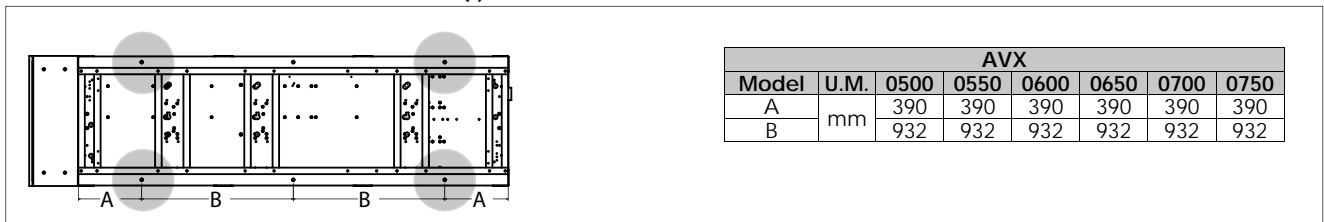

NXW 0800 VERSION TOTAL RECOVERY(T)

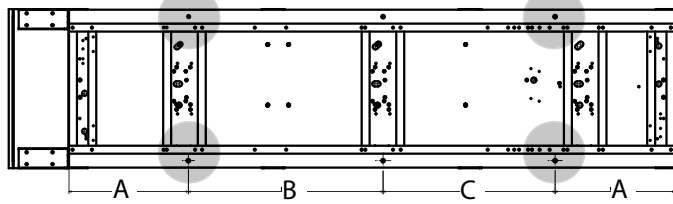

AVX		
Model	U.M.	0800
A	mm	600
B		979
C		865

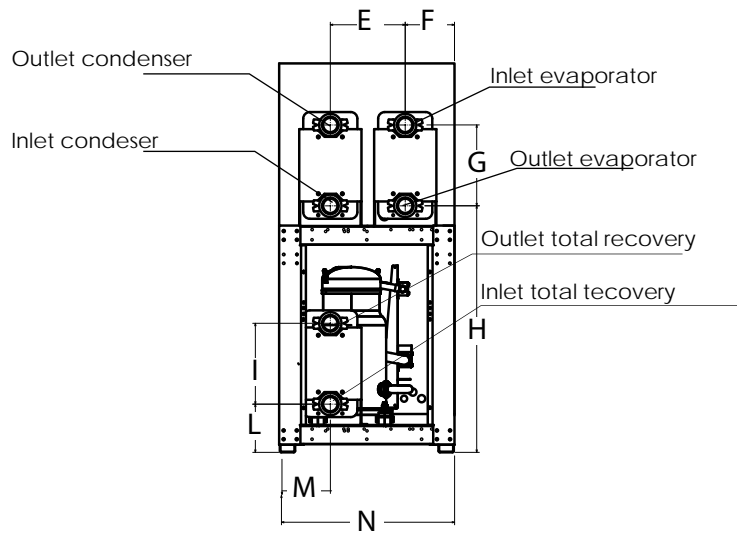
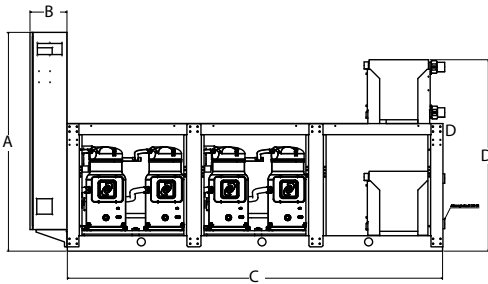

POSITION		
Model	U.M.	0800
A	m	1775
B		300
C		3044
D		1553
E		343
F		225
G		369
H		1125
I		369
L		220
M		233
N		800

HYDRAULIC CONNECTION (VICTAULIC IN/OUT)		
Evaporator (plates)	∅	2"1/2
Condensater (plates)		2"1/2
Total Recovery (plates)		2"1/2

NXW 0900 VERSION TOTAL RECOVERY(T)

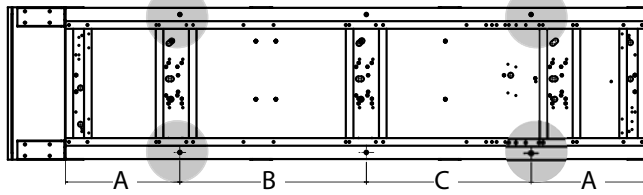

AVX		
Model	U.M.	0900
A	mm	600
B		979
C		865

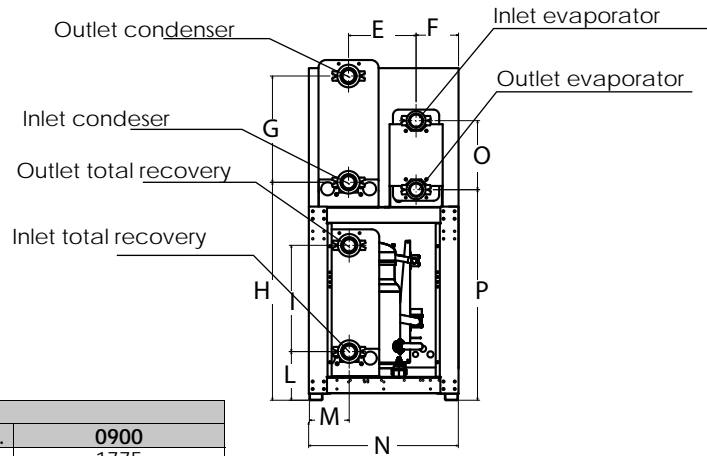
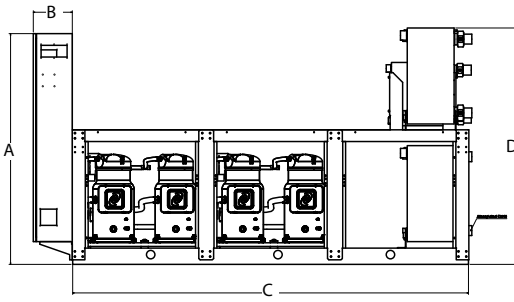

POSITION		
Model	U.M.	0900
A	m	1775
B		300
C		3044
D		1818
E		343
F		225
G		568
H		1165
I		568
L		260
M		213
N		800
O		369
P		1125
HYDRAULIC CONNECTION (VICTAULIC IN/OUT)	U.M.	0900 0900 H
Evaporator (plates)	∅	2" 1/2 3"
Condensater (plates)		2" 1/2 3"
Total Recovery (plates)		2" 1/2 3"

NXW 1000-1250-1400 VERSION TOTAL RECOVERY(T)

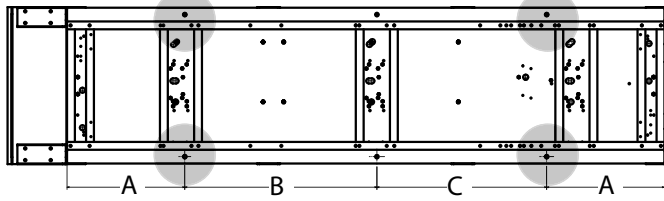

AVX				
Model	U.M.	1000	1250	1400
A	mm	600	600	600
B		979	979	979
C		865	865	865

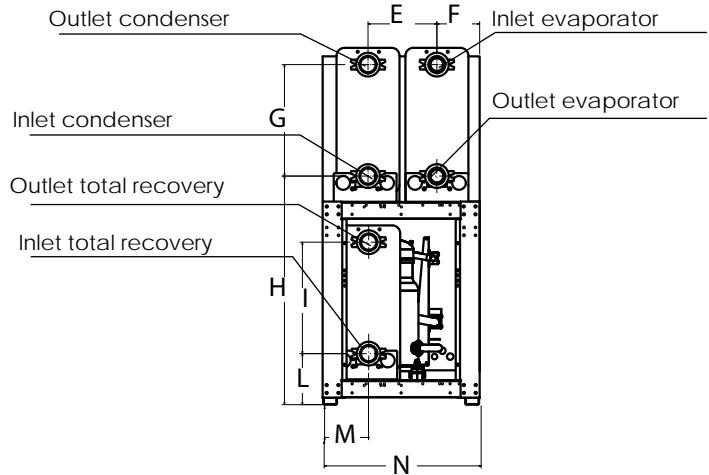
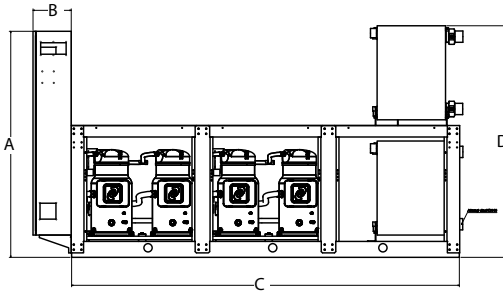

POSITION				
Model	U.M.	1000	1250	1400
A	m	1775		
B		300		
C		3044		
D		1818		
E		367		
F		216		
G		568		
H		1165		
I		568		
L		260		
M		216		
N	800			
HYDRAULIC CONNECTION (VICTAULIC IN/OUT)				
Evaporator (plates)	∅		3"	
Condenser (plates)			3"	
Total Recovery (plates)			3"	

NXW version condenserless (E)
 Model 0500 - 0550 - 600 - 650 - 700 - 750

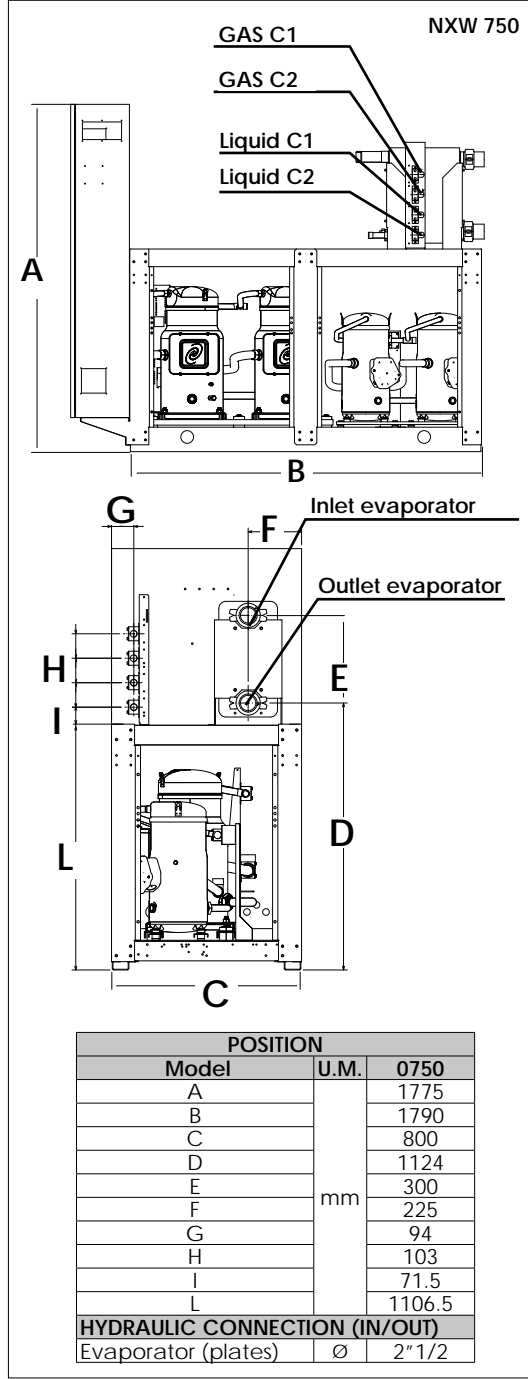
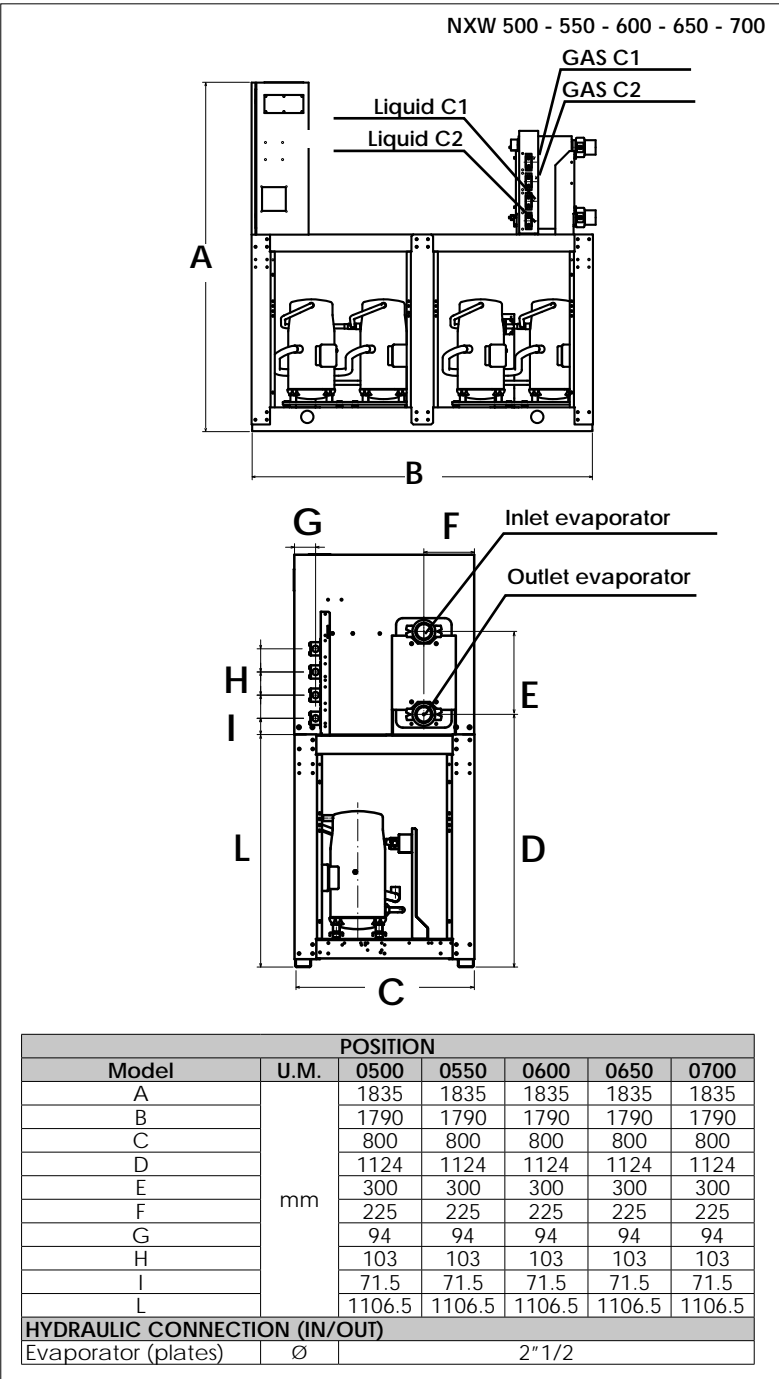
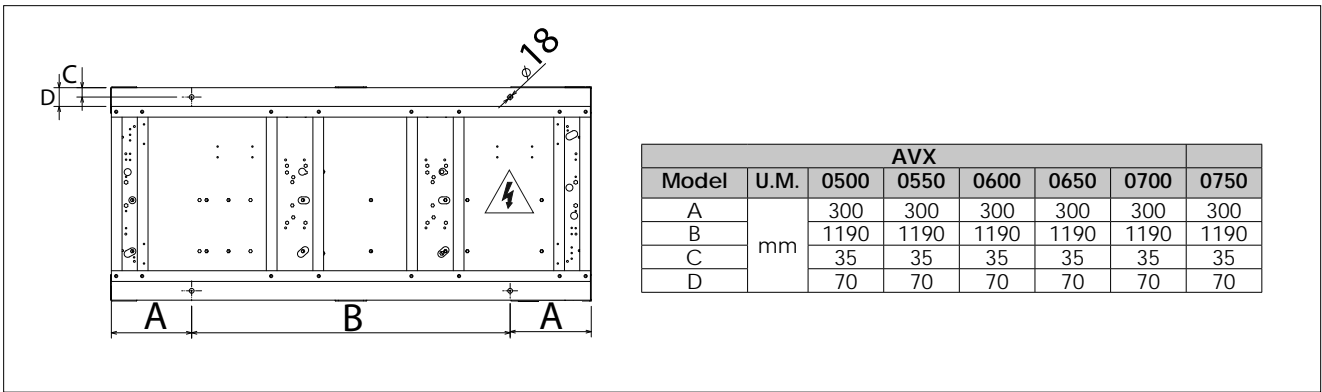

NXW version condensersless (E)
models 0800 - 0900

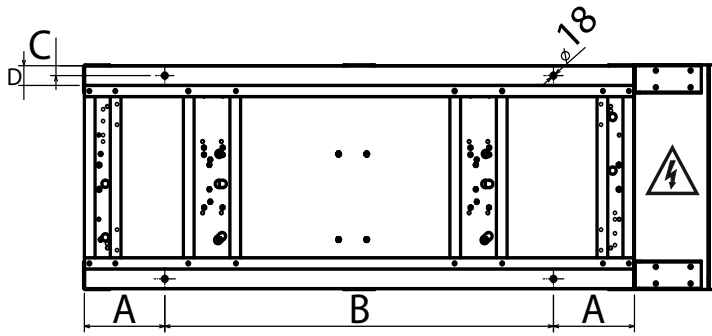

AVX			
Model	U.M.	0800	0900
A	mm	300	300
B		1454	1454
C		35	35
D		70	70

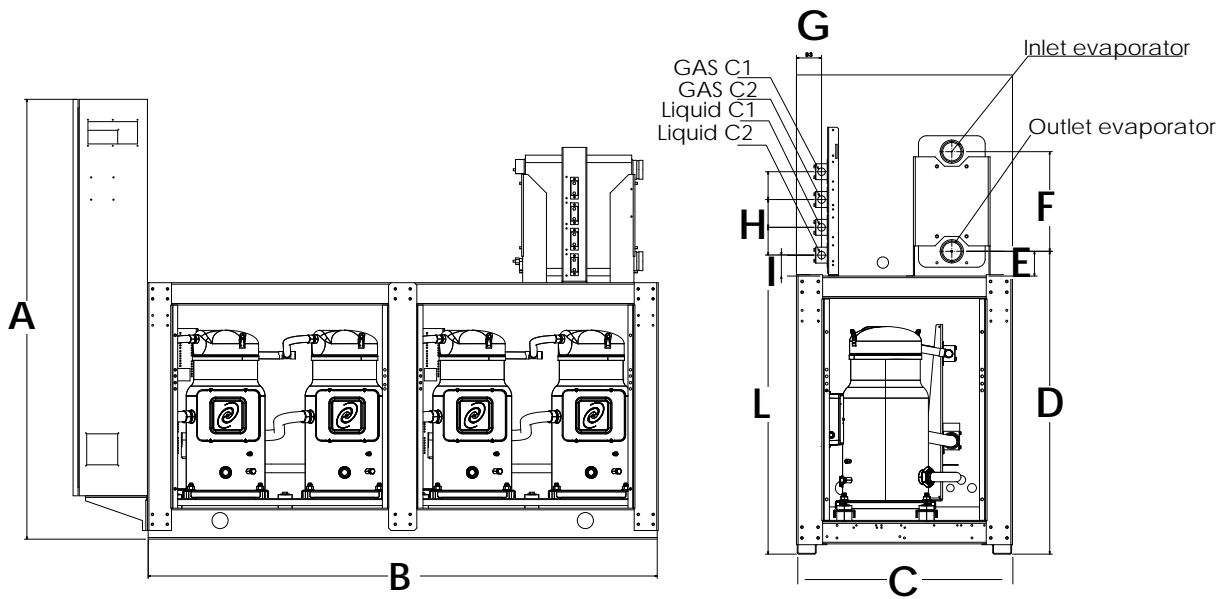

Dimensions		
Model	U.M.	0800 0900
A	mm	1775
B		2054
C		800
D		1121.72
E		92
F		369
G		93
H		103
I		77.5
L	1107.5	
HYDRAULIC CONNECTION (VICTAULIC IN/OUT)		
Evaporator (plates)	Ø	2" 1/2

NXW version condenserless (E)
models 1000-1250-1400

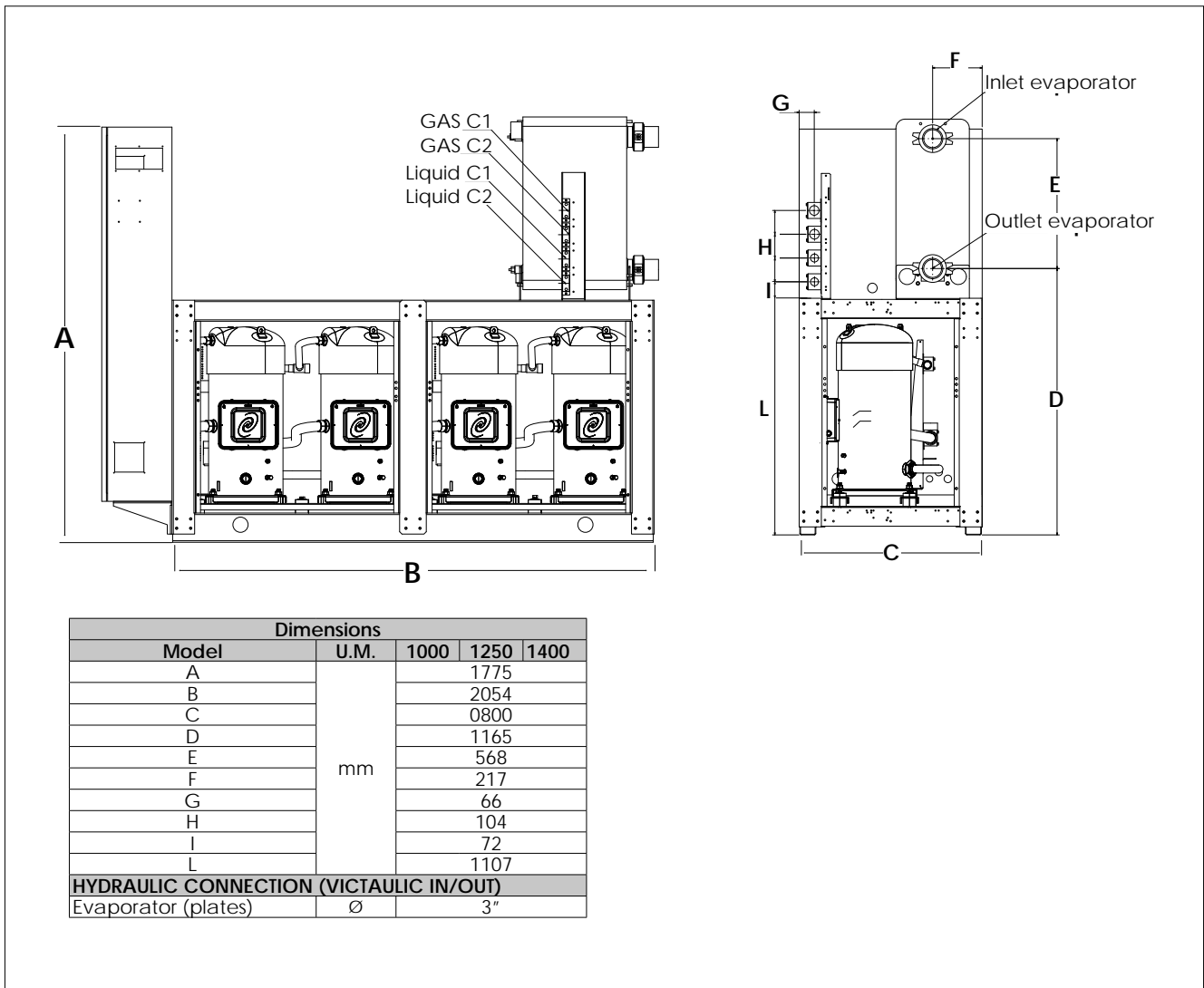
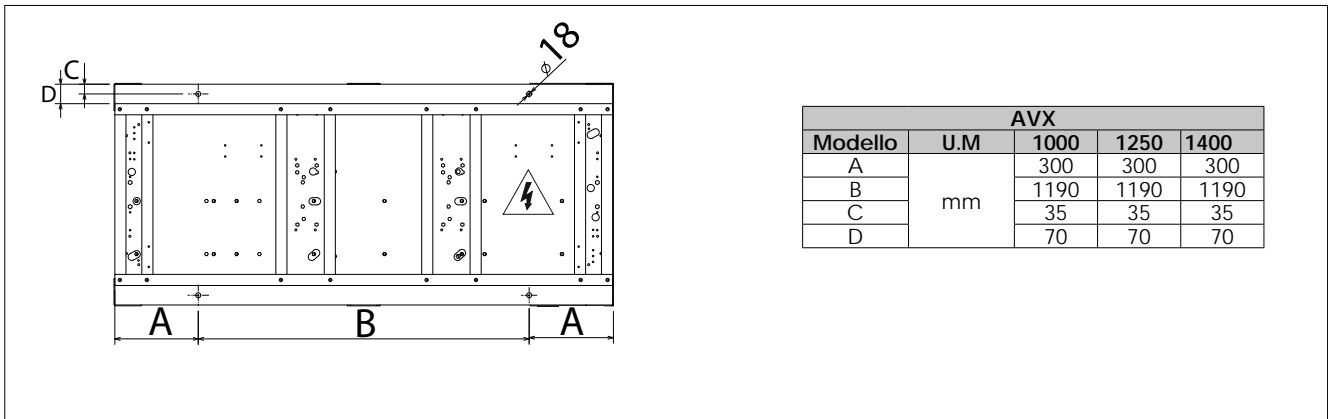

NXW version condensersless (E)
models 1000-1250-1400 pumps

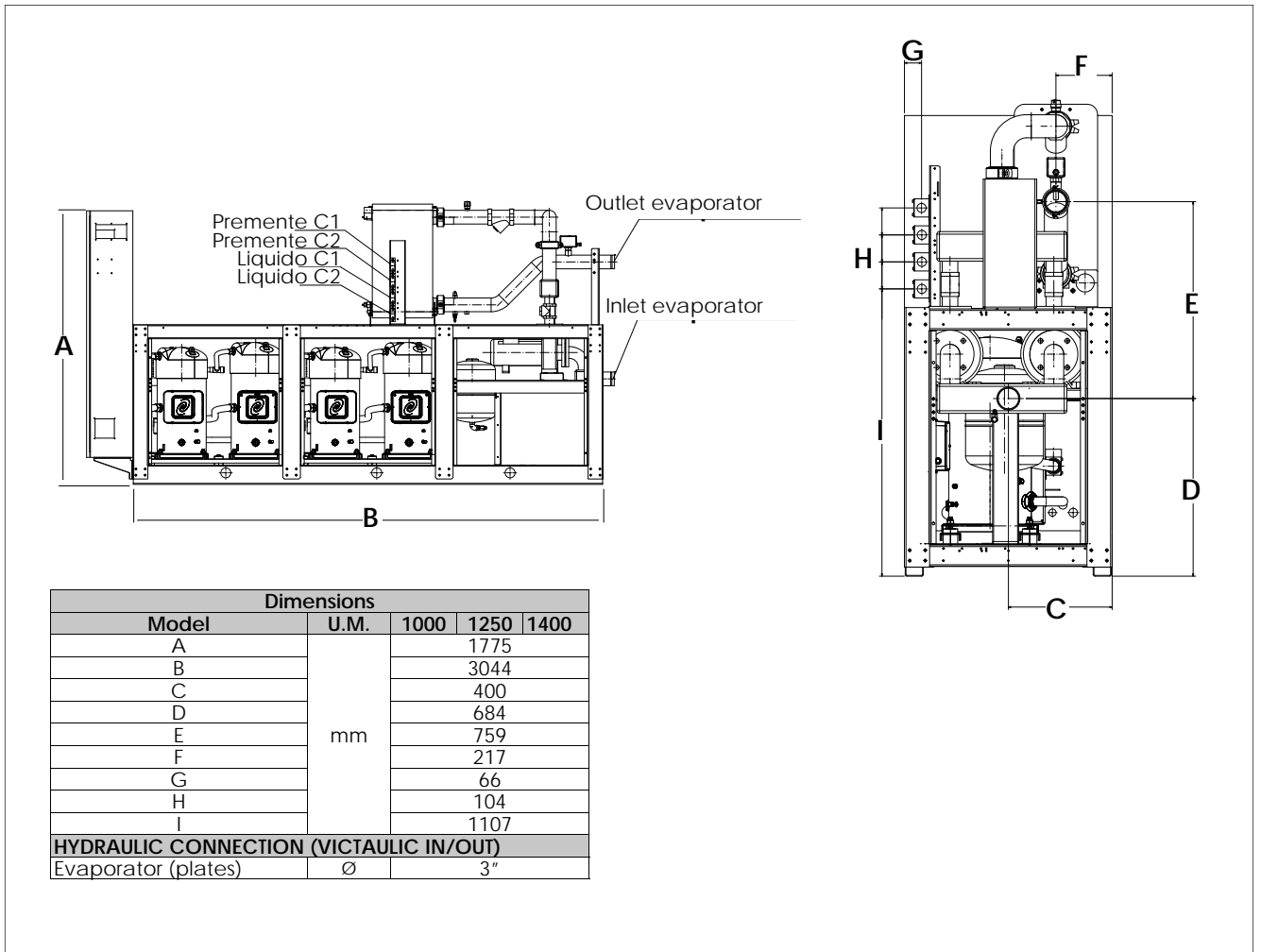
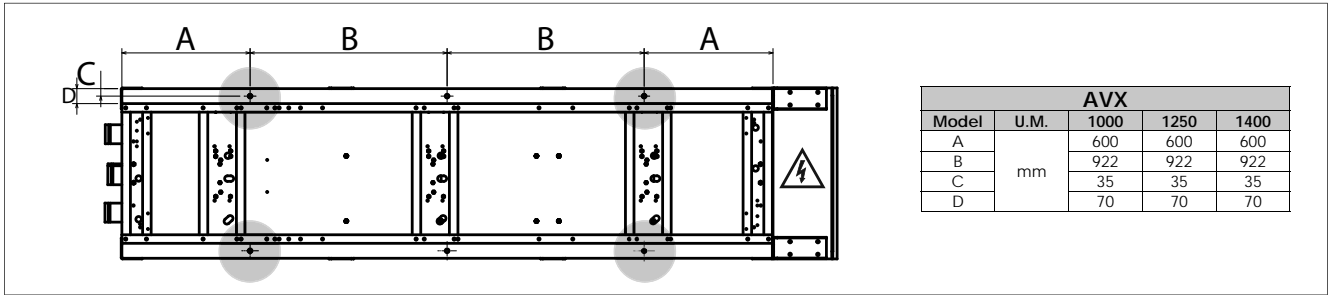

21. HYDRAULIC CIRCUIT

The NXW standard version is comprised of a circuit including:

- Evaporator (plate type exchanger)
- Condenser (plate type exchanger)
- Water inlet probe SIW
- Water outlet probe SUW

NB:

Water filter versions standard: NOT INCLUDED

the weld pipe is supplied as standard with the VICTAULIC connection is included

The NXW version with pumping group also includes:

- Circulation pump
- Water filter
- Drain valve
- Flow switch
- Water outlet/inlet probe
- Expansion tank (25 litres)

21.1. EXTERNAL HYDRAULIC CIRCUIT RECOMMENDED

The selection and installation of components outside the NXW should be carried out by the installer, who should work according to the technical code of practice and in compliance with the legislation in force in the country of destination (MD 329/2004).

Before connecting the pipes make sure that they do not contain stones, sand, rust, slag or any foreign bodies that may damage the system. It is necessary to make a by-pass to the unit to be able to carry out the cleaning of the pipes without having to disconnect the machine. The connection pipes must be properly supported so as not to burden the unit with their weight.

On the water circuit, it is advisable to install the following instruments, if not foreseen in the version you have:

1. Two pressure gauges of suitable size (input and output section).
 2. Two anti-vibration couplings (input and output section).
 3. Two shut-off valves (normal input section, output section calibrating valve).
 4. Two thermometers (input and output section).
 5. Expansion tanks
 6. Pump
 7. Accumulation tank
 8. Flow switch
 9. Safety valve
 10. Charging unit
 11. Water filter
- The filter protects only the exchangers (in case of particularly dirty water, we recommend an external filter to protect the pumps)*

Compulsory hydraulic circuit components (in case of an NXW provided without the hydronic kit (evaporator side, condenser side):

- At the inlet or each plate heat exchanger the installation of a flow switch (not included) is compulsory at the penalty of invalidating the warranty.

- Installation of the mechanical filter is compulsory at the inlet of each plate heat exchanger at the penalty of invalidating the warranty. The filter must have filtering holes with a diameter not greater than one millimetre and must be kept clean, therefore the cleaning must be verified after installation of the unit and the condition must be checked periodically.

It is necessary, that the water flow rate to the chiller unit complies with the values reported in the performance tables.

The systems loaded with anti-freeze or specific regulations, need the water

backflow system.

Special supply/recovery water, is carried out with appropriate treatment systems.

21.2. SYSTEM LOAD

- Before starting the load, check that the system drain tap is closed.
- Open all the drain valves of the system and of the related terminals.
- Open the shut-off devices of the system.
- Start the filling by slowly opening the water system load cock placed outside the machine.
- When water begins to flow from the terminal vent valves, close them and continue loading up to read on the gauge the value of 1.5 bar.

The system is loaded at a pressure between 1 and 2 bar.

It is advisable to repeat this operation once the machine has worked for some hours and to periodically check the system pressure, restoring if it drops below 1 bar.

Check the hydraulic seal of the joints.

21.3. EMPTYING THE SYSTEM

- Before starting to drain the system, turn "off" the unit
- Check that the water system load/restore tap is closed
- Open the drain tap outside the machine and all the vent valves of the system and the corresponding terminals.

If the system uses glycol, this liquid should not be drained to the environment because it is a pollutant. It must be collected and, if possible, reused.

Example of NXW Version [H]

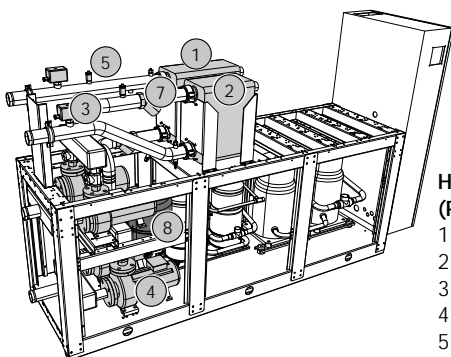

HYDRAULIC CIRCUIT KEY (PUMP VERSION)

- 1 Condenser
- 2 Evaporator
- 3 Flow switch
- 4 Pumps
- 5 Air bleed valve
- 6 Water discharge
- 7 Filter
- 8 Expansion tank

NB

The Victaulic joints and the soldering studs for the condenser and evaporator are provided

WATER FEATURES

PH	6-8
Electric conductivity	less than 200 mV/cm (25°C)
Chloride ions	less than 50 ppm
Sulphuric acid ions	less than 50 ppm
Total iron	less than 0.3 ppm
Alkalinity M	less than 50 ppm
Total hardness	less than 50 ppm
Sulphur ions	none
ammonia ions	none
Silicone ions	less than 30 ppm

22. PERCENTAGE DISTRIBUTION OF WEIGHTS ON SUPPORTS

22.1. PERCENTAGE DISTRIBUTION OF WEIGHTS ON SUPPORTS (VERSION ° - SIZE FROM 0500 TO 0750)

MODEL		EMPTY			PERCENTAGE WEIGHT DISTRIBUTION ON SUPPORTS (%)				AVX
		Weight	CENTRE OF GRAVITY		A	B	C	D	
			Xg	Yg					
NXW0500	°	578	410	832	27%	28%	22%	23%	319
NXW0500	° + 1 pump	680	403	914	33%	33%	17%	17%	320
NXW0500	° + 2 pumps	727	400	985	32%	32%	18%	18%	
NXW0500	° + 3 pumps	774	398	1047	31%	30%	19%	19%	
NXW0500	° + 4 pumps	822	396	1169	29%	28%	22%	21%	309

NXW0550	°	582	410	829	27%	28%	22%	23%	319
NXW0550	° + 1 pump	684	403	911	33%	33%	17%	17%	320
NXW0550	° + 2 pumps	732	401	982	32%	32%	18%	18%	
NXW0550	° + 3 pumps	779	398	1043	31%	31%	19%	19%	
NXW0550	° + 4 pumps	826	396	1165	29%	28%	22%	21%	309

NXW0600	°	682	414	900	25%	27%	23%	25%	301
NXW0600	° + 1 pump	784	408	962	32%	33%	17%	18%	320
NXW0600	° + 2 pumps	831	405	1021	31%	31%	19%	19%	309
NXW0600	° + 3 pumps	878	403	1074	30%	30%	20%	20%	
NXW0600	° + 4 pumps	926	401	1181	28%	28%	22%	22%	310

NXW0650	°	690	415	899	25%	27%	23%	25%	301
NXW0650	° + 1 pump	796	408	965	31%	33%	17%	18%	309
NXW0650	° + 2 pumps	847	406	1027	31%	31%	19%	19%	
NXW0650	° + 3 pumps	897	403	1082	30%	30%	20%	20%	
NXW0650	° + 4 pumps	948	401	1189	28%	28%	22%	22%	310

NXW0700	°	727	417	915	24%	26%	24%	26%	301
NXW0700	° + 1 pump	833	411	1043	30%	32%	19%	20%	309
NXW0700	° + 2 pumps	883	408	1097	29%	30%	20%	21%	
NXW0700	° + 3 pumps	934	405	1146	28%	29%	21%	22%	
NXW0700	° + 4 pumps	984	403	1190	28%	28%	22%	22%	310

NXW0750	°	882	419	1082	24%	26%	24%	26%	303
NXW0750	° + 1 pump	997	413	1212	29%	31%	19%	21%	312
NXW0750	° + 2 pumps	1058	410	1273	28%	30%	21%	22%	
NXW0750	° + 3 pumps	1118	408	1327	27%	28%	22%	22%	
NXW0750	° + 4 pumps	1159	406	1360	27%	28%	22%	23%	

⚠ NOTE

- The number of pumps refers to the quantity physically present on the machine.
- The weight difference between the types of configurator pumps (low head and high head) is negligible.

⚠ NOTE

Version with desuperheater (D)

- use the same positions for antivibration pad fixing as for the AVX of the standard version
- desuperheater additional weight : 23 kg for all models from 500 to 800 size / 29 kg. for all models from 900 to 1400 size

**22.2. PERCENTAGE DISTRIBUTION OF WEIGHTS ON SUPPORTS
(VERSION ° - SIZES FROM 0800 TO 1400)**

MODEL		EMPTY			PERCENTAGE WEIGHT DISTRIBUTION ON SUPPORTS (%)				AVX
		Weight	CENTRE OF GRAVITY		A	B	C	D	
			Xg	Yg					
NXW0800	°	989	421	1224	23%	26%	24%	27%	310
NXW0800	° + 1 pump	1105	415	1244	28%	30%	20%	21%	651
NXW0800	° + 2 pumps	1165	412	1297	28%	29%	21%	22%	
NXW0800	° + 3 pumps	1226	410	1345	27%	28%	22%	23%	
NXW0800	° + 4 pumps	1286	407	1389	26%	27%	23%	24%	

NXW0900	°	1180	427	1217	23%	27%	23%	27%	314
NXW0900	° + 1 pump	1296	421	1336	29%	32%	19%	21%	665
NXW0900	° + 2 pumps	1356	419	1391	28%	31%	20%	21%	
NXW0900	° + 3 pumps	1417	416	1441	28%	30%	20%	22%	
NXW0900	° + 4 pumps	1477	414	1487	27%	29%	21%	23%	

NXW1000	°	1417	428	1309	21%	25%	25%	29%	316
NXW1000	° + 1 pump	1558	422	1421	27%	31%	20%	22%	653
NXW1000	° + 2 pumps	1644	419	1481	27%	30%	21%	23%	
NXW1000	° + 3 pumps	1730	416	1535	26%	29%	22%	23%	
NXW1000	° + 4 pumps	1765	415	1555	26%	28%	22%	24%	

NXW1250	°	1461	426	1304	22%	25%	25%	29%	316
NXW1250	° + 1 pump	1602	421	1414	28%	31%	20%	22%	654
NXW1250	° + 2 pumps	1688	418	1472	27%	30%	21%	23%	
NXW1250	° + 3 pumps	1774	415	1525	27%	29%	22%	23%	
NXW1250	° + 4 pumps	1809	414	1546	26%	28%	22%	24%	

NXW1400	°	1539	425	1326	21%	24%	26%	29%	315
NXW1400	° + 1 pump	1680	420	1429	28%	30%	20%	22%	654
NXW1400	° + 2 pumps	1765	417	1485	27%	29%	21%	23%	
NXW1400	° + 3 pumps	1851	415	1535	26%	28%	22%	23%	
NXW1400	° + 4 pumps	1886	414	1554	26%	28%	22%	24%	

▲ NOTE

- The number of pumps refers to the quantity physically present on the machine.
- The weight difference between the types of configurator pumps (low head and high head) is negligible.

▲ NOTE

Version with desuperheater (D)

- use the same positions for antivibration pad fixing as for the AVX of the standard version
- desuperheater additional weight : 23 kg for all models from 500 to 800 size / 29 kg. for all models from 900 to 1400 size

**22.3. PERCENTAGE DISTRIBUTION OF WEIGHTS ON SUPPORTS
(VERSION H - SIZES FROM 0500 TO 0750)**

MODEL		EMPTY			PERCENTAGE WEIGHT DISTRIBUTION ON SUPPORTS (%)				AVX
		Weight	CENTRE OF GRAVITY		A	B	C	D	
			Xg	Yg					
NXW0500H	H	628	401	849	27%	27%	23%	23%	319
NXW0500H	H + 1 pump	730	396	923	33%	33%	17%	17%	320
NXW0500H	H + 2 pumps	778	394	989	32%	31%	19%	18%	
NXW0500H	H + 3 pumps	825	392	1047	31%	30%	20%	19%	309
NXW0500H	H + 4 pumps	872	390	1098	30%	29%	21%	20%	

NXW0550H	H	633	401	846	27%	27%	23%	23%	319
NXW0550H	H + 1 pump	735	396	920	33%	33%	17%	17%	320
NXW0550H	H + 2 pumps	782	394	985	32%	31%	19%	18%	
NXW0550H	H + 3 pumps	829	392	1043	31%	30%	20%	19%	309
NXW0550H	H + 4 pumps	877	391	1095	30%	29%	21%	20%	

NXW0600H	H	734	406	911	25%	26%	24%	25%	301
NXW0600H	H + 1 pump	836	401	968	32%	32%	18%	18%	320
NXW0600H	H + 2 pumps	884	399	1023	31%	31%	19%	19%	309
NXW0600H	H + 3 pumps	931	397	1073	30%	30%	20%	20%	
NXW0600H	H + 4 pumps	978	395	1118	30%	29%	21%	20%	312

NXW0650H	H	743	407	910	25%	26%	24%	25%	301
NXW0650H	H + 1 pump	848	401	970	32%	32%	18%	18%	309
NXW0650H	H + 2 pumps	899	399	1028	31%	31%	19%	19%	
NXW0650H	H + 3 pumps	950	397	1080	30%	30%	20%	20%	311
NXW0650H	H + 4 pumps	1000	396	1127	29%	29%	21%	21%	312

NXW0700H	H	791	406	932	24%	25%	25%	26%	302
NXW0700H	H + 1 pump	896	401	1048	31%	31%	19%	19%	309
NXW0700H	H + 2 pumps	947	399	1099	30%	30%	20%	20%	311
NXW0700H	H + 3 pumps	997	397	1145	29%	29%	21%	21%	312
NXW0700H	H + 4 pumps	1048	395	1186	28%	28%	22%	22%	

NXW0750H	H	948	410	1103	24%	25%	25%	26%	310
NXW0750H	H + 1 pump	1064	405	1223	27%	28%	22%	23%	651
NXW0750H	H + 2 pumps	1124	403	1279	26%	26%	24%	24%	
NXW0750H	H + 3 pumps	1185	401	1330	25%	25%	25%	25%	
NXW0750H	H + 4 pumps	1225	399	1361	27%	27%	23%	23%	

⚠ NOTE

- The number of pumps refers to the quantity physically present on the machine.
- The weight difference between the types of configurator pumps (low head and high head) is negligible.

⚠ NOTE

Version with desuperheater (D)

- use the same positions for antivibration pad fixing as for the AVX of the standard version
- desuperheater additional weight : 23 kg for all models from 500 to 800 size / 29 kg. for all models from 900 to 1400 size

**22.4. PERCENTAGE DISTRIBUTION OF WEIGHTS ON SUPPORTS
(VERSION H - SIZES FROM 0800 TO 1400)**

MODEL		EMPTY			PERCENTAGE WEIGHT DISTRIBUTION ON SUPPORTS (%)				AVX
		Weight	CENTRE OF GRAVITY		A	B	C	D	
			Xg	Yg					
NXW0800H	H	1042	415	1227	24%	26%	24%	26%	310
NXW0800H	H + 1 pump	1157	410	1244	29%	30%	20%	21%	651
NXW0800H	H + 2 pumps	1218	408	1295	28%	29%	21%	22%	
NXW0800H	H + 3 pumps	1278	406	1341	27%	28%	22%	23%	
NXW0800H	H + 4 pumps	1339	404	1384	27%	27%	23%	23%	

NXW0900H	H	1275	415	1240	23%	25%	25%	27%	314
NXW0900H	H + 1 pump	1391	411	1348	29%	31%	19%	20%	665
NXW0900H	H + 2 pumps	1451	409	1399	29%	30%	20%	21%	
NXW0900H	H + 3 pumps	1512	407	1446	28%	29%	21%	22%	
NXW0900H	H + 4 pumps	1572	405	1489	28%	28%	22%	22%	

NXW1000H	H	1545	413	1333	22%	23%	27%	28%	316
NXW1000H	H + 1 pump	1686	409	1435	28%	30%	21%	22%	654
NXW1000H	H + 2 pumps	1771	407	1489	28%	29%	22%	22%	
NXW1000H	H + 3 pumps	1857	405	1539	27%	28%	22%	23%	
NXW1000H	H + 4 pumps	1892	404	1558	27%	27%	23%	23%	

NXW1250H	H	1577	414	1322	22%	23%	26%	28%	315
NXW1250H	H + 1 pump	1718	410	1423	28%	30%	20%	21%	654
NXW1250H	H + 2 pumps	1803	408	1477	28%	29%	21%	22%	
NXW1250H	H + 3 pumps	1889	406	1527	27%	28%	22%	23%	
NXW1250H	H + 4 pumps	1924	405	1546	27%	28%	22%	23%	

NXW1400H	H	1657	413	1342	22%	23%	27%	29%	317
NXW1400H	H + 1 pump	1797	409	1437	28%	30%	21%	22%	654
NXW1400H	H + 2 pumps	1883	407	1488	28%	29%	21%	22%	
NXW1400H	H + 3 pumps	1969	405	1535	27%	28%	22%	23%	
NXW1400H	H + 4 pumps	2004	404	1554	27%	27%	23%	23%	

⚠ NOTE

- The number of pumps refers to the quantity physically present on the machine.
- The weight difference between the types of configurator pumps (low head and high head) is negligible.

⚠ NOTE

Version with desuperheater (D)

- use the same positions for antivibration pad fixing as for the AVX of the standard version
- desuperheater additional weight : 23 kg for all models from 500 to 800 size / 29 kg. for all models from 900 to 1400 size

**22.5. PERCENTAGE DISTRIBUTION OF WEIGHTS ON SUPPORTS
(VERSION L - SIZES FROM 0500 TO 0750)**

MODEL		EMPTY			PERCENTAGE WEIGHT DISTRIBUTION ON SUPPORTS (%)				AVX
		Weight	CENTRE OF GRAVITY		A	B	C	D	
			Xg	Yg					
NXW0500L	L	750	399	834	28%	27%	23%	22%	309
NXW0500L	L + 1 pump	932	392	895	34%	33%	17%	16%	321
NXW0500L	L + 2 pumps	979	391	948	33%	32%	18%	17%	311
NXW0500L	L + 3 pumps	1026	389	996	32%	31%	19%	18%	
NXW0500L	L + 4 pumps	1074	388	1183	29%	27%	23%	21%	312

NXW0550L	L	755	399	832	28%	27%	23%	22%	309
NXW0550L	L + 1 pump	936	392	892	34%	33%	17%	16%	321
NXW0550L	L + 2 pumps	983	391	946	33%	32%	18%	17%	311
NXW0550L	L + 3 pumps	1031	390	994	32%	31%	19%	18%	
NXW0550L	L + 4 pumps	1078	389	1180	29%	27%	22%	21%	312

NXW0600L	L	854	404	888	26%	26%	24%	24%	310
NXW0600L	L + 1 pump	1036	397	933	33%	32%	17%	17%	311
NXW0600L	L + 2 pumps	1083	395	979	32%	32%	18%	18%	
NXW0600L	L + 3 pumps	1130	394	1022	32%	31%	19%	19%	312
NXW0600L	L + 4 pumps	1178	393	1191	28%	27%	22%	22%	

NXW0650L	L	863	405	887	26%	26%	24%	24%	303
NXW0650L	L + 1 pump	1048	397	935	33%	32%	17%	17%	311
NXW0650L	L + 2 pumps	1098	396	984	32%	31%	18%	18%	
NXW0650L	L + 3 pumps	1149	394	1029	31%	31%	19%	19%	312
NXW0650L	L + 4 pumps	1200	393	1197	28%	27%	23%	22%	310

NXW0700L	L	900	407	901	25%	26%	24%	25%	303
NXW0700L	L + 1 pump	1084	400	1085	30%	30%	20%	20%	651
NXW0700L	L + 2 pumps	1135	398	1126	29%	29%	21%	21%	
NXW0700L	L + 3 pumps	1186	396	1164	29%	28%	22%	21%	
NXW0700L	L + 4 pumps	1236	395	1198	28%	27%	22%	22%	

NXW0750L	L	1054	410	1087	24%	25%	25%	26%	310
NXW0750L	L + 1 pump	1249	403	1271	29%	29%	21%	21%	651
NXW0750L	L + 2 pumps	1310	401	1318	28%	28%	22%	22%	
NXW0750L	L + 3 pumps	1370	399	1360	27%	27%	23%	23%	
NXW0750L	L + 4 pumps	1411	398	1386	27%	27%	23%	23%	

⚠ NOTE

- The number of pumps refers to the quantity physically present on the machine.
- The weight difference between the types of configurator pumps (low head and high head) is negligible.

⚠ NOTE

Version with desuperheater (D)

- use the same positions for antivibration pad fixing as for the AVX of the standard version
- desuperheater additional weight : 23 kg for all models from 500 to 800 size / 29 kg. for all models from 900 to 1400 size

**22.6. PERCENTAGE DISTRIBUTION OF WEIGHTS ON SUPPORTS
(VERSION L - SIZES FROM 0800 TO 1400)**

MODEL		Weight	EMPTY		PERCENTAGE WEIGHT DISTRIBUTION ON SUPPORTS (%)				AVX
			CENTRE OF GRAVITY		A	B	C	D	
			Xg	Yg					
NXW0800L	L	1187	411	1226	24%	25%	25%	26%	314
NXW0800L	L + 1 pump	1357	405	1292	28%	29%	21%	22%	652
NXW0800L	L + 2 pumps	1417	403	1334	28%	28%	22%	22%	
NXW0800L	L + 3 pumps	1478	402	1373	27%	27%	23%	23%	
NXW0800L	L + 4 pumps	1538	400	1408	27%	27%	23%	23%	

NXW0900L	L	1378	418	1220	24%	26%	24%	26%	314
NXW0900L	L + 1 pump	1585	411	1399	29%	30%	20%	21%	653
NXW0900L	L + 2 pumps	1646	409	1442	28%	29%	21%	22%	
NXW0900L	L + 3 pumps	1706	407	1482	28%	29%	21%	22%	
NXW0900L	L + 4 pumps	1767	406	1519	27%	28%	22%	23%	

NXW1000L	L	1615	420	1300	22%	24%	26%	28%	315
NXW1000L	L + 1 pump	1847	413	1462	28%	29%	21%	22%	654
NXW1000L	L + 2 pumps	1933	411	1511	27%	29%	22%	23%	
NXW1000L	L + 3 pumps	2019	409	1556	27%	28%	22%	23%	
NXW1000L	L + 4 pumps	2054	408	1573	26%	27%	23%	24%	

NXW1250L	L	1659	419	1296	22%	24%	26%	28%	315
NXW1250L	L + 1 pump	1891	412	1455	28%	29%	21%	22%	659
NXW1250L	L + 2 pumps	1977	410	1503	27%	29%	22%	23%	
NXW1250L	L + 3 pumps	2063	408	1547	27%	28%	22%	23%	
NXW1250L	L + 4 pumps	2098	407	1564	27%	27%	23%	23%	

NXW1400L	L	1737	418	1316	22%	24%	26%	28%	317
NXW1400L	L + 1 pump	1969	411	1466	28%	29%	21%	22%	659
NXW1400L	L + 2 pumps	2055	409	1512	27%	28%	22%	23%	
NXW1400L	L + 3 pumps	2140	407	1555	27%	28%	22%	23%	
NXW1400L	L + 4 pumps	2176	407	1571	26%	27%	23%	24%	

⚠ NOTE

- The number of pumps refers to the quantity physically present on the machine.
- The weight difference between the types of configurator pumps (low head and high head) is negligible.

⚠ NOTE

Version with desuperheater (D)

- use the same positions for antivibration pad fixing as for the AVX of the standard version
- desuperheater additional weight : 23 kg for all models from 500 to 800 size / 29 kg. for all models from 900 to 1400 size

**22.7. PERCENTAGE DISTRIBUTION OF WEIGHTS ON SUPPORTS
(VERSION HL - SIZES FROM 0500 TO 750)**

MODEL		EMPTY			PERCENTAGE WEIGHT DISTRIBUTION ON SUPPORTS (%)				AVX
		Weight	CENTRE OF GRAVITY		A	B	C	D	
			Xg	Yg					
NXW0500HL	HL	801	393	847	28%	27%	23%	22%	309
NXW0500HL	HL + 1 pump	982	387	902	34%	32%	17%	16%	311
NXW0500HL	HL + 2 pumps	1030	386	952	33%	31%	18%	17%	
NXW0500HL	HL + 3 pumps	1077	385	998	33%	30%	19%	18%	312
NXW0500HL	HL + 4 pumps	1124	384	1041	32%	30%	20%	19%	

NXW0550HL	HL	805	393	845	28%	27%	23%	22%	309
NXW0550HL	HL + 1 pump	987	388	900	34%	32%	17%	16%	311
NXW0550HL	HL + 2 pumps	1034	387	950	33%	31%	18%	17%	
NXW0550HL	HL + 3 pumps	1081	386	996	33%	30%	19%	18%	312
NXW0550HL	HL + 4 pumps	1129	385	1038	32%	30%	20%	18%	

NXW0600HL	HL	907	398	897	26%	26%	24%	24%	310
NXW0600HL	HL + 1 pump	1088	392	938	33%	32%	18%	17%	311
NXW0600HL	HL + 2 pumps	1135	391	983	33%	31%	19%	18%	312
NXW0600HL	HL + 3 pumps	1183	390	1023	32%	30%	19%	18%	
NXW0600HL	HL + 4 pumps	1230	389	1061	31%	30%	20%	19%	

NXW0650HL	HL	915	399	897	26%	26%	24%	24%	303
NXW0650HL	HL + 1 pump	1100	393	941	33%	32%	18%	17%	311
NXW0650HL	HL + 2 pumps	1151	391	987	32%	31%	19%	18%	313
NXW0650HL	HL + 3 pumps	1201	390	1030	32%	30%	20%	19%	
NXW0650HL	HL + 4 pumps	1252	389	1069	31%	29%	20%	19%	

NXW0700HL	HL	963	398	916	25%	25%	25%	25%	304
NXW0700HL	HL + 1 pump	1148	393	1088	30%	29%	21%	20%	651
NXW0700HL	HL + 2 pumps	1199	392	1126	30%	29%	21%	20%	
NXW0700HL	HL + 3 pumps	1249	390	1162	29%	28%	22%	21%	
NXW0700HL	HL + 4 pumps	1300	389	1194	29%	27%	23%	22%	

NXW0750HL	HL	1121	403	1105	24%	24%	26%	26%	314
NXW0750HL	HL + 1 pump	1316	397	1277	27%	26%	24%	23%	652
NXW0750HL	HL + 2 pumps	1376	395	1321	26%	25%	25%	24%	
NXW0750HL	HL + 3 pumps	1437	394	1361	25%	24%	26%	25%	
NXW0750HL	HL + 4 pumps	1477	393	1386	27%	27%	23%	23%	

⚠ NOTE

- The number of pumps refers to the quantity physically present on the machine.
- The weight difference between the types of configurator pumps (low head and high head) is negligible.

⚠ NOTE

Version with desuperheater (D)

- use the same positions for antivibration pad fixing as for the AVX of the standard version
- desuperheater additional weight : 23 kg for all models from 500 to 800 size / 29 kg. for all models from 900 to 1400 size

**22.8. PERCENTAGE DISTRIBUTION OF WEIGHTS ON SUPPORTS
(VERSION HL - SIZES FROM 0800 TO 1400)**

MODEL		Weight	EMPTY		PERCENTAGE WEIGHT DISTRIBUTION ON SUPPORTS (%)				AVX
			CENTRE OF GRAVITY		A	B	C	D	
			Xg	Yg					
NXW0800HL	HL	1240	407	1228	24%	25%	25%	26%	314
NXW0800HL	HL + 1 pump	1409	402	1291	28%	29%	21%	22%	665
NXW0800HL	HL + 2 pumps	1470	400	1331	28%	28%	22%	22%	
NXW0800HL	HL + 3 pumps	1530	399	1368	27%	27%	23%	23%	
NXW0800HL	HL + 4 pumps	1591	397	1403	27%	27%	23%	23%	

NXW0900HL	HL	1473	408	1239	24%	25%	25%	26%	315
NXW0900HL	HL + 1 pump	1680	402	1406	29%	30%	21%	21%	653
NXW0900HL	HL + 2 pumps	1740	401	1446	29%	29%	21%	21%	
NXW0900HL	HL + 3 pumps	1801	400	1484	28%	28%	22%	22%	
NXW0900HL	HL + 4 pumps	1861	399	1519	28%	28%	22%	22%	

NXW1000HL	HL	1743	408	1322	22%	23%	27%	28%	317
NXW1000HL	HL + 1 pump	1975	402	1471	28%	29%	22%	22%	659
NXW1000HL	HL + 2 pumps	2061	401	1516	28%	28%	22%	22%	
NXW1000HL	HL + 3 pumps	2147	399	1558	27%	27%	23%	23%	
NXW1000HL	HL + 4 pumps	2182	399	1575	27%	27%	23%	23%	

NXW1250HL	HL	1775	408	1313	22%	23%	27%	28%	317
NXW1250HL	HL + 1 pump	2007	403	1460	28%	29%	21%	22%	659
NXW1250HL	HL + 2 pumps	2093	402	1506	28%	28%	22%	22%	
NXW1250HL	HL + 3 pumps	2178	400	1548	27%	27%	23%	23%	
NXW1250HL	HL + 4 pumps	2214	399	1564	27%	27%	23%	23%	

NXW1400HL	HL	1855	408	1331	22%	23%	27%	28%	318
NXW1400HL	HL + 1 pump	2087	403	1471	28%	29%	21%	22%	659
NXW1400HL	HL + 2 pumps	2173	401	1514	28%	28%	22%	22%	
NXW1400HL	HL + 3 pumps	2258	400	1554	27%	27%	23%	23%	
NXW1400HL	HL + 4 pumps	2294	399	1570	27%	27%	23%	23%	

⚠ NOTE

- The number of pumps refers to the quantity physically present on the machine.
- The weight difference between the types of configurator pumps (low head and high head) is negligible.

⚠ NOTE

Version with desuperheater (D)

- use the same positions for antivibration pad fixing as for the AVX of the standard version
- desuperheater additional weight : 23 kg for all models from 500 to 800 size / 29 kg. for all models from 900 to 1400 size

**22.9. PERCENTAGE DISTRIBUTION OF WEIGHTS ON SUPPORTS VERSION TOTAL RECOVERY (T)
ALL SIZE**

MODEL		EMPTY			PERCENTAGE WEIGHT DISTRIBUTION ON SUPPORTS (%)				AVX
		Weight	CENTRE OF GRAVITY		A	B	C	D	
			Xg	Yg					
NXW0500	T	728	419	1200	26%	29%	21%	23%	303
NXW0550		733	419	1195	27%	29%	21%	23%	303
NXW0600		852	424	1269	25%	28%	22%	25%	310
NXW0650		860	4045	1235	27%	27%	23%	23%	310
NXW0700		914	428	1303	24%	28%	22%	26%	310
NXW0750		1060	431	1477	23%	27%	23%	26%	314
NXW0800		1190	430	1487	23%	27%	23%	27%	652
NXW0900		1443	437	1658	23%	28%	22%	27%	315
NXW1000		1756	442	1801	21%	26%	24%	29%	322
NXW1250		1805	440	1790	21%	26%	24%	29%	322
NXW1400		1912	440	1824	21%	25%	24%	29%	322

**22.10. PERCENTAGE DISTRIBUTION OF WEIGHTS ON SUPPORTS VERSION
SILENCED MODE WITH TOTAL RECOVERY (T) ALL SIZE**

MODEL		EMPTY			PERCENTAGE WEIGHT DISTRIBUTION ON SUPPORTS (%)				AVX
		Weight	CENTRE OF GRAVITY		A	B	C	D	
			Xg	Yg					
NXW0500	LT	980	404	1207	27%	28%	22%	23%	312
NXW0550		985	405	1204	27%	28%	22%	23%	312
NXW0600		1104	410	1259	26%	27%	23%	24%	651
NXW0650		1112	395	1233	27%	27%	23%	23%	651
NXW0700		1166	414	1287	25%	27%	23%	25%	652
NXW0750		1312	418	1482	24%	27%	23%	26%	652
NXW0800		1441	418	1490	24%	26%	24%	26%	652
NXW0900		1732	425	1662	24%	27%	23%	26%	323
NXW1000		2045	431	1784	22%	26%	24%	28%	324
NXW1250		2094	430	1775	22%	26%	24%	28%	324
NXW1400		2202	430	1805	22%	25%	25%	29%	324

**22.11. PERCENTAGE DISTRIBUTION OF WEIGHTS ON SUPPORTS
VERSION CONDESERLESS (E)-ALL SIZE**

MODEL		EMPTY			PERCENTAGE WEIGHT DISTRIBUTION ON SUPPORTS (%)				AVX
		Weight	CENTRE OF GRAVITY		A	B	C	D	
			Xg	Yg					
NXW0500	E	525	396	771	29%	29%	21%	21%	319
NXW0550		530	397	768	29%	29%	21%	21%	319
NXW0600		610	399	835	28%	27%	23%	22%	301
NXW0650		619	400	834	27%	27%	23%	23%	301
NXW0700		638	400	840	27%	27%	23%	23%	301
NXW0750		796	406	1013	26%	27%	23%	24%	303
NXW0800		904	409	1161	25%	27%	23%	25%	310
NXW0900		1044	411	1130	26%	27%	23%	24%	314
NXW1000		1260	413	1237	24%	25%	25%	26%	316
NXW1250		1304	412	1234	24%	25%	25%	26%	316
NXW1400		1358	409	1252	24%	25%	25%	26%	315

**22.12. PERCENTAGE DISTRIBUTION OF WEIGHTS ON SUPPORTS
VERSION CONDENSERLESS - SILENCED MODE (E)-ALL SIZE**

MODEL	Weight	EMPTY		PERCENTAGE WEIGHT DISTRIBUTION ON SUPPORTS (%)				AVX
		CENTRE OF GRAVITY		A	B	C	D	
		Xg	Yg					
NXW0500	697	388	787	30%	28%	22%	21%	309
NXW0550	702	389	786	30%	28%	22%	21%	309
NXW0600	782	391	835	28%	27%	23%	22%	310
NXW0650	791	392	836	28%	27%	23%	22%	303
NXW0700	810	392	839	28%	27%	23%	22%	303
NXW0750	968	399	1030	26%	26%	24%	24%	310
NXW0800	1104	400	1176	26%	26%	24%	24%	314
NXW0900	1244	404	1148	26%	27%	23%	24%	314
NXW1000	1460	407	1238	24%	25%	25%	26%	315
NXW1250	1504	406	1235	24%	25%	25%	26%	315
NXW1400	1558	403	1251	24%	24%	26%	26%	317

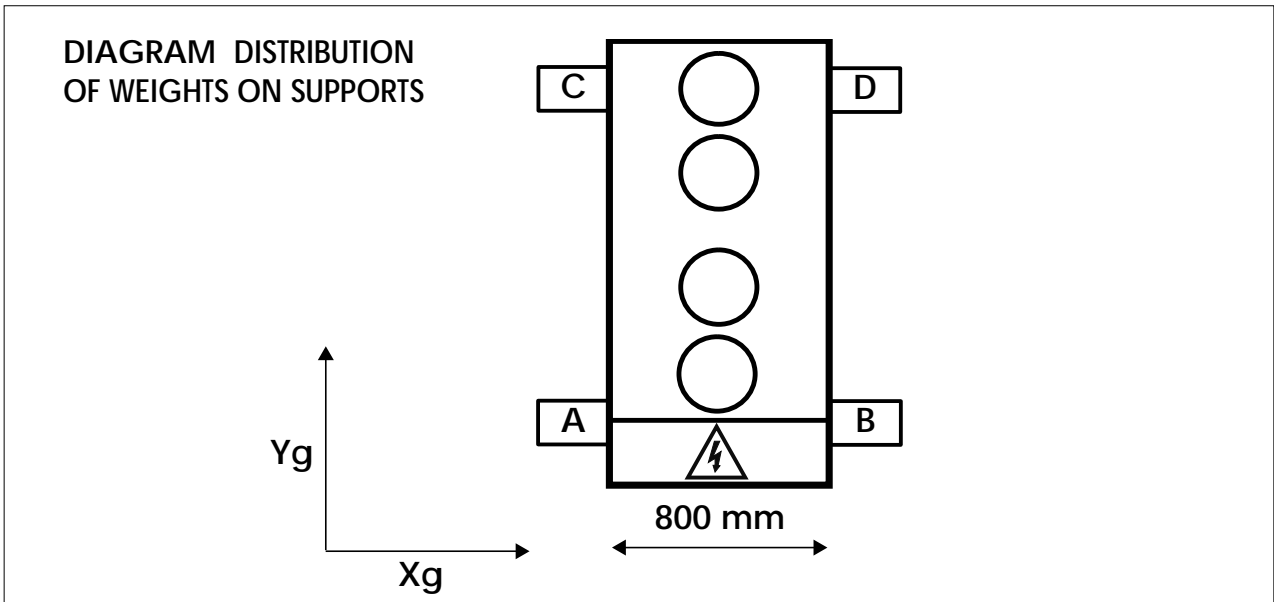

23. ELECTRICAL WIRINGS

NXW chillers are completely wired in the factory and only need the connection to the electricity mains supply, downstream from a group switch, according to the regulations in force in the country where the machine is installed. It is also suggested to check:

- the mains supply characteristics, to ensure it is suitable for the levels indicated in the electrical data table, also taking into consideration any other equipment that may be operating at the same time.
- The unit is only powered after the last (hydraulic and electric) installations.
- Follow the connections instructions of the phase conductors, and earth.
- The power supply line will have a special protection upstream against short circuits and earth losses that sections the system according to other users.
- The voltage should be within a tolerance of $\pm 10\%$ of the rated supply voltage of the machine (for Three-phase units displacement max 3% between the phases). If these parameters are not respected, contact the energy supplier. For electrical wirings use isolated double cables according to the standards in force in the different countries.



All electrical operations must be carried out BY QUALIFIED PERSONNEL, IN ACCORDANCE WITH THE CORRESPONDING REGULATIONS, trained and informed about the risks related to such operations.



The characteristics of electric lines and related components must be established by PERSONNEL AUTHORISED TO DESIGN ELECTRIC INSTALLATIONS, following international regulations and the national regulations of the country in which the unit is installed, in compliance with the legislative regulations in force at the moment of installation.



For installation requirements, the wiring layout supplied with the unit must be compulsory referred to. The wiring layout together with the manuals must be kept in good conditions and readily ACCESSIBLE FOR FUTURE OPERATIONS ON THE UNIT.



It is compulsory to check the machine sealing before connecting the electrical wirings. The machine should only be powered once the hydraulic and electric operations are completed.

- It is necessary to use a omnipolar thermomagnetic switch, in compliance with the CEI-EN standards (contact opening of at least 3 mm), with adequate switch capability and differential protection based on the followed electrical data table, installed as close as possible to the machine.
- It is necessary to carry out an efficient earth connection. The manufacturer can not be held responsible for any damage caused by the failure and ineffective earthing of the machine.
- For units with Three-phase power

check the correct connection of the phases.

WARNING:

It is forbidden to use water pipes for the earthing of the machine.

23.1. RECOMMENDED SECTION OF ELECTRIC CABLES

The cable sections indicated in the table are advised for a maximum length of 50 m.

ELECTRICAL DATA VERSION ° WITHOUT PUMPING GROUP (ALL VERSIONS)

Model	MAX RECOMMENDED LENGTH (metres)	SECT. A (400V-3)	SECT.B	EARTH (400V-3)	IL (400V-3)
		U.M.	U.M.	U.M.	U.M.
		mm ²	mm ²	mm ²	A
NXW 0500	50	16	1.5	16	80
NXW 0550		16		16	100
NXW 0600		25		16	100
NXW 0650		25		16	125
NXW 0700		35		16	160
NXW 0750		50		25	160
NXW 0800		70		35	200
NXW 0900		70		35	200
NXW 1000		70		35	250
NXW 1250		95		50	250
NXW 1400		95		50	250

KEY

- Sec. A: Power supply
- Sec. B: Controls and safety connection
- Earth
- IL: Main switch

**ELECTRICAL DATA VERSION WITH PUMPING GROUP
(ALL VERSIONS)**

Model	MAX RECOMMENDED LENGTH	SECT. A (400V-3)	SECT.B	EARTH (400V-3)	IL (400V-3)
	U.M.	U.M.	U.M.	U.M.	U.M.
	MT	mm ²	mm ²	mm ²	A
NXW 0500	50	16	1.5	16	100
NXW 0550		25		16	100
NXW 0600		25		16	125
NXW 0650		35		16	125
NXW 0700		50		25	160
NXW 0750		50		25	160
NXW 0800		70		35	200
NXW 0900		70		35	200
NXW 1000		95		50	250
NXW 1250		95		50	250
NXW 1400		95		50	250

KEY

- Sec. A: Power supply
- Sec. B: Controls and safety connection
- Earth
- IL: Main switch

For higher lengths or different types of cable installation, it will be the DESIGNERS responsibility to carefully measure the line main switch, the supply power line and the earthing protection connection, and the working connection cables:

- the length
- the type of cable
- Absorption of the unit and its physical position, and room temperature.

WARNING:
Check that all power cables are correctly secured to the terminals when switched on for the first time and after 30 days of use. Afterwards, check the connection of the power cables every six months. Slack terminals could cause the cables and components to overheat.

23.2. CONNECTION TO THE POWER SUPPLY

- Check there is no voltage on the electric line you want to use.

23.2.1. To access the electric box:

- Turn the electrical panel screws ¼ in counter-clockwise direction
- Turn the handle of the door-block disconnecting switch to OFF (see figure). In this way, the electrical panel can be accessed



▲
Fig.1

23.3. ELECTRICAL POWER CONNECTION

- For the functional connection of the unit, run the power supply cable to the electrical panel inside the unit fig. 1 and connect it to the disconnecting switch terminals observing the phase and the earth. fig. 2

23.4. AUXILIARY CONNECTIONS AT THE USER/INSTALLER EXPENSE

For installation requirements, refer to the wiring diagram supplied with the unit. The wiring diagram together with the manuals must be kept in good conditions and readily ACCESSIBLE FOR FUTURE OPERATIONS ON THE UNIT.

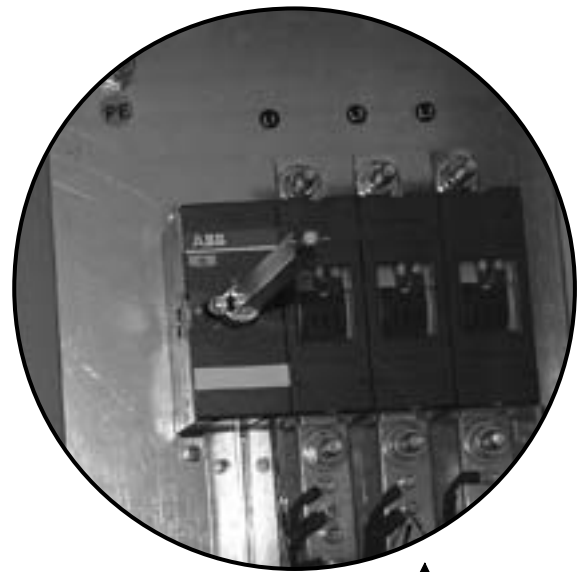

▲
Fig.2

Key fig. 2	
L1	Line 1
L2	Line 2
L3	Line 3
PE	Earth

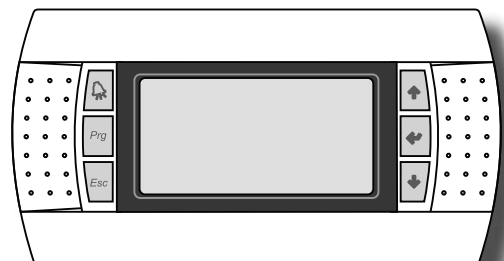

24. CONTROL AND FIRST START-UP

24.1. PREPARATION FOR COMMISSIONING

Bear in mind that a free start-up service is offered by the Aermec Technical Service for the unit of this series, at the request of Aermec customers or legitimate owners and in ITALY only.

The start-up must be previously agreed on the basis of the system implementation times. Before the intervention of the AERMEC After Sales Service, all the operations (electrical and hydraulic hook ups, loading and breather from the system) must be completed.

Before starting the unit make sure that:

- All the safety conditions have been respected
- The unit has been properly fixed to the support base
- The minimum technical spaces have been observed;
- Water connections have been performed respecting the input and output
- The hydraulic system has been loaded and vented.
- The hydraulic circuit taps are open
- The electrical wirings have been properly carried out;
- The voltage is within a tolerance of 10% of the unit rated voltage
- The earthing has been carried out correctly
- Tightening of all electrical and hydraulic connections have been well carried out.

24.2. FIRST COMMISSIONING OF THE MACHINE

Before activating the unit:

- Close the electric panel lid.
- Position the door-block disconnecting switch of the machine on ON, turning the handle down. **(fig.3)**
- The display on (fig.4) indicates that the unit is ready for operation.

For more information see the USER'S MANUAL

24.3. SEASON CHANGEOVER

For the season changeover, see the user's manual.

WARNING

The first start-up has to be carried out with the standard settings, only when the test is finished the values of the operation Set Point vary. Before starting up, power the unit for at least 12-24 hours by positioning the protection thermomagnetic switch and the door-block disconnecting switch on ON fig.1 Make sure that the control panel is turned off until it allows the oil heater system the compressor casing.

Fig.3

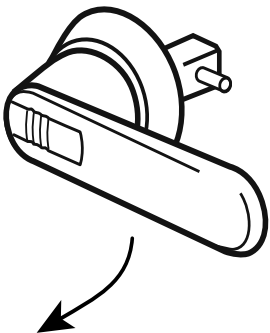

Display on on



Fig.4

25. OPERATION CHARACTERISTICS

25.1. COOLING SET POINT

(Default defined) = 7°C, $\Delta t = 5^\circ\text{C}$.

25.2. HEATING SET POINT

(Default defined) = 45°C, $\Delta t = 5^\circ\text{C}$.

In case of restoring of the unit supplied power after a momentary interruption, the pre-set mode is maintained in memory.

25.3. COMPRESSOR START-UP DELAY

To prevent the compressor start too close to each other, two functions have been arranged.

- Minimum time from last turnoff 60 seconds.
- Minimum time from last start 300 seconds.

25.4. CIRCULATION PUMP

The electronic board provides an output to manage the circulation pump. After the first 10 seconds of pump

operation, when the water flow rate is running, activate the function of water flow rate alarm (flow switch).

25.5. ANTI-FREEZE ALARM

The anti-freeze alarm is active as if the machine is turned-off or if the machine is in standby mode. In order to prevent breakage of the plate-type exchanger due to freezing water contained, the compressor is locked (if the machine is turned on under 4° C) and the heater starts up (if standby below 5° C). If the temperature detected by the probe in the exchanger output and in the chiller input is below +4 ° C.

WARNING

THE ANTI-FREEZE SET TEMPERATURE CAN BE VARIED ONLY BY AN AUTHORISED SERVICE CENTRE AND ONLY AFTER VERIFYING THAT IN THE WATER CIRCUIT IS AN ANTIFREEZE SOLUTION.

The intervention of this alarm sets the compressor block and not of the pump block, which remains active, and the heater starts up if installed.

For resetting the normal functions, the water output temperature has to be over +4 ° C, the reset is manual.

26. REGULAR MAINTENANCE

Any cleaning operation is forbidden before disconnecting the unit from the power supply.

Check for voltage before operating. Periodic maintenance is essential to maintain the unit in perfect working order under the functional as well as the energetic aspect.

Therefore it is essential to provide yearly controls for the:

26.6.1. Hydraulic circuit

CONTROL:

- Water circuit filling
- Water filter cleaning
- Flow switch control
- Air in the circuit (leaks)
- That the water flow rate to the evaporator is always constant
- The hydraulic piping thermal insulation state
- Where provided the percentage of glycol

26.6.2. Electric circuit

CONTROL:

- Efficiency of safety devices
- Electrical power supply
- Electrical power consumption
- Connections tightened
- Compressor casing heater operation

WARNING:

AT ANY INTERVENTIONS OF THIS ALARM IT IS RECOMMENDED TO IMMEDIATELY CONTACT THE NEAREST TECHNICAL SERVICE ASSISTANCE

25.6. WATER FLOW RATE ALARM

The PGD1 provides the management of a water flow rate alarm commanded from a flow switch installed on the machine as standard. This safety type can occur after the first 10 seconds of operation of the pump if the water flow rate is not sufficient.

This alarm sets the block of the compressor and the pump.

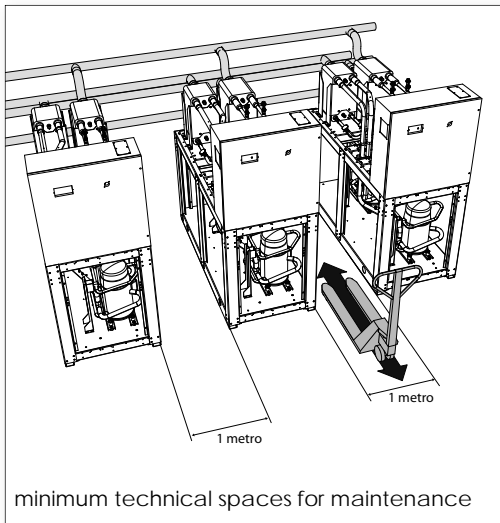

minimum technical spaces for maintenance

WARNING

Inspection, maintenance and possible repair operations must be carried out only by an authorised technician according to the law.

Unsuitable check/maintenance operation may cause damage to things and people.

26.6.3. Cooling circuit

CONTROL:

- Compressor conditions
- Efficiency of the tube core exchanger heater
- Working pressure
- Loss test for the control of the the cooling circuit sealing
- High and low pressure switches operation
- Perform the necessary checks on the filter-drier to verify their efficiency.

26.6.4. Mechanical controls

CONTROL:

- The screws, compressors and the electric box of the unit external panning are properly tightened. If they are poorly tightened, they produce abnormal noise and vibrations
- The structure conditions. If necessary, treat oxidised parts with paints suitable for eliminating or reducing oxidation.

27. EXTRAORDINARY MAINTENANCE

The NXW are loaded with R410A gas and tested in the factory. In normal conditions, no Technical Assistance Service operation is needed for the refrigerant gas check. In the long run, however, small leaks from the joints may arise. Due to these leaks, the refrigerant comes out and the circuit is

drained, causing the unit to malfunction. In these cases, the refrigerant leakage points are found and repaired, and the cooling circuit is recharged, operating in compliance with Law 28 December 1993 no. 549.

27.6.1. Loading procedure

The loading procedure is as follows:

- Empty and dehydrate the entire cooling circuit using a vacuum pump connected to both the low and high pressure test points, until the vacuum gauge reads about 10 Pa. Wait some minutes and check that this value does not go back again over 50 Pa.
 - Connect the refrigerant gas bomb or a load cylinder to the grip on the low-pressure line.
 - Charge the amount of refrigerant gas indicated on the characteristics plate of the machine.
 - After any operation control that the liquid indicator indicates a dry circuit (dry-green) In case of partial loss the circuit has to be emptied completely before reloading it.
- The refrigerant R410A has to be loaded only in liquid phase.
 - Different operating conditions from the normal can result in different values.
 - Leak testing or leaking research must be carried out only by using refrigerant gas R410A by checking with a suitable leak detection.
 - It is prohibited to use oxygen or acetylene or other flammable or poisonous gas in the cooling circuit, because they can cause explosions or intoxication.

It is advisable to keep a machine booklet (not supplied, but provided by the user), in order to keep trace of the operations carried out on the unit. In this way, it will be easier to organise the operations properly and facilitate failure prevention and troubleshooting in the machine.

In the booklet, write down date, type of operation carried out (regular maintenance, inspection or repair), description of the operation, measures taken...

It is forbidden to CHARGE the cooling circuits with a refrigerant different from the one indicated. If a different refrigerant gas is used, the compressor may be seriously damaged.

DISPOSAL

Provided that the disposal of the unit is carried out according to the rules in force in different countries.



paper recycled
recycled paper
Papiere recycle
recycled paper



The technical data in the following documentation are not binding. Aermec reserves the right to make all the modifications considered necessary for improving the product at any time.
