

CORNICE DI MANDATA E D'ASPIRAZIONE
DELIVERY AND INTAKE FRAME
GRILLE DE SOUFLAGE ET D'ASPIRATION
AUSBLAS- UND ANSAUGGITTER
PLAFON DE ENVÍO Y DE ASPIRACIÓN

GLL10

GLL20

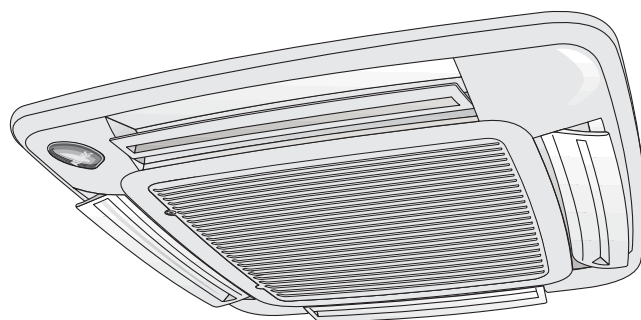

GLL10

FCL 32	(600x600)
FCL 36	(600x600)
FCL 42	(600x600)
FCL 62	(600x600)
FCL 34	(600x600)
FCL 38	(600x600)
FCL 44	(600x600)
FCL 64	(600x600)

GLL20

FCL 82	(840x840)
FCL 102	(840x840)
FCL 122	(840x840)
FCL 84	(840x840)
FCL 104	(840x840)
FCL 124	(840x840)



AGLLIJ 1012 - 4528550_03

OSSERVAZIONI

Conservare i manuali in luogo asciutto, per evitare il deterioramento, per almeno 10 anni per eventuali riferimenti futuri. **Leggere attentamente e completamente tutte le informazioni contenute in questo manuale. Prestare particolarmente attenzione alle norme d'uso accompagnate dalle scritte "PERICOLO" o "ATTENZIONE" in quanto, se non osservate, possono causare danno alla macchina e/o a persone e cose.**

Per anomalie non contemplate da questo manuale, interpellare tempestivamente il Servizio Assistenza di zona.

L'apparecchio deve essere installato in maniera tale da rendere possibili operazioni di manutenzione e/o riparazione.

REMARKS

Store the manuals in a dry location to avoid deterioration, as they must be kept for at least 10 years for any future reference. **All the information in this manual must be carefully read and understood. Pay particular attention to the operating standards with "DANGER" or "WARNING" signals as failure to comply with them can cause damage to the machine and/or persons or objects.**

If any malfunctions are not included in this manual, contact the local After-sales Service immediately.

La garanzia dell'apparecchio non copre in ogni caso i costi dovuti ad autoscale, ponteggi o altri sistemi di elevazione che si rendessero necessari per effettuare gli interventi in garanzia.

AERMEC S.p.A. declina ogni responsabilità per qualsiasi danno dovuto ad un uso improprio della macchina, ad una lettura parziale o superficiale delle informazioni contenute in questo manuale.

Alcune immagini potrebbero illustrare particolari forniti come accessori a pagamento.

Il numero di pagine di questo manuale è: 48

The apparatus must be installed in such a way that maintenance and/or repair operations are possible.

The apparatus's warranty does not in any case cover costs due to automatic ladders, scaffolding or other lifting systems necessary for carrying out repairs under guarantee.

AERMEC S.p.A. declines all responsibility for any damage whatsoever caused by improper use of the machine, and a partial or superficial acquaintance with the information contained in this manual.

The number of pages in this manual is : 48

REMARQUES

Conserver les manuels dans un endroit sec, afin d'éviter leur détérioration, pendant au moins 10 ans, pour toutes éventuelles consultations futures.

Lire attentivement et entièrement toutes les informations contenues dans ce manuel. Prêter une attention particulière aux normes d'utilisation signalées par les inscriptions "DANGER" ou "ATTENTION", car leur non observance pourrait causer un dommage à l'appareil et/ou aux personnes et objets.

Pour toute anomalie non mentionnée dans ce manuel, contacter aussitôt le service après-vente de votre secteur.

Lors de l'installation de l'appareil, il faut prévoir l'espace nécessaire pour les opérations d'entretien et/ou de réparation.

La garantie de l'appareil ne couvre pas les coûts dérivant de l'utilisation de voitures avec échelle mécanique, d'échafaudages ou d'autres systèmes de levée employés pour effectuer des interventions en garantie.

AERMEC S.p.A. décline toute responsabilité pour tout dommage dû à une utilisation improprie de l'appareil et à une lecture partielle ou superficielle des informations contenues dans ce manuel.

Ce manuel se compose de pages: 48

HINWEISE

Bewahren Sie die Gebrauchsanleitungen mindestens 10 Jahre für eventuelles zukünftiges Nachschlagen an einem trockenen Ort auf. **Alle in diesem Handbuch enthaltenen Informationen aufmerksam und vollständig lesen. Insbesondere auf die Benutzungsanweisungen mit den Hinweisen "VORSICHT" oder "ACHTUNG" achten, da deren Nichtbeachtung Schäden am Gerät bzw. Sach- und Personenschäden zur Folge haben kann.**

Bei Betriebsstörungen, die in dieser Gebrauchsanweisung nicht aufgeführt sind, wenden Sie sich umgehend an die zuständige

Kundendienststelle.

Das Gerät so aufstellen, dass Instandhaltungs- und/oder Reparaturarbeiten durchgeführt werden können.

Die Garantie des Gerätes deckt in keinem Fall Kosten für Feuerwehrlern, Gerüste oder andere Hebesysteme ab, die sich für die Garantiearbeiten als erforderlich erweisen sollten.

Die AERMEC S.p.A. übernimmt keine Haftung für Schäden aus dem unsachgemäßen Gebrauch des Gerätes und der teilweisen oder oberflächlichen Lektüre der in diesem Handbuch enthaltenen Informationen.

Die Seitenanzahl diese Handbuches ist: Nr. 48 Seiten

OBSERVACIONES

Guarde los manuales en un lugar seco para evitar su deterioro, al menos durante 10 años, por si fuera posible consultarlos en el futuro.

Leer atenta y completamente todas las informaciones contenidas en este manual. Preste particular atención a las normas de uso acompañadas de las indicaciones "PELIGRO" o "ATENCIÓN" puesto que, si no se cumplen, pueden causar el deterioro de la máquina y/o daños personales y materiales.

En caso de anomalías no contempladas en este manual, contacte inmediatamente con el Servicio de Asistencia de su zona.

El aparato debe ser instalado de manera que haga posibles las

operaciones de mantenimiento y/o reparación.

En cualquier caso, la garantía del aparato no cubre los costes derivados del uso de escaleras automáticas, andamios u otros sistemas de elevación necesarios para efectuar las intervenciones en garantía.

AERMEC S.p.A. declina cualquier responsabilidad por cualquier daño debido a un uso impropio de la máquina, o bien a una lectura parcial o superficial de las informaciones contenidas en este manual.

Número de páginas de este manual:48

INDICE

**DICHIARAZIONE DI CONFORMITÀ
DECLARATION OF CONFORMITY
DÉCLARATION DE CONFORMITÉ
KONFORMITÄTSEKTLÄRUNG
DECLARACIÓN DE CONFORMIDAD**

4

Trasporto • Simboli di sicurezza
Transport • Safety symbols
Transport • Symboles de sécurité
Transport • Sicherheitssymbole
Transporte • Símbolos de seguridad

5

Italiano

6

English

14

Français

22

Deutsche

30

Español

38

AERMEC S.p.A.

I-37040 Bevilacqua (VR) Italia – Via Roma, 996
Tel. (+39) 0442 633111
Telefax (+39) 0442 93730 – (+39) 0442 93566
www.aermec.com - info@aermec.com

I presenti prodotti devono essere installati, esclusivamente, in abbinamento con le unità FCL. Solo rispettando tali abbinamenti è valida la seguente dichiarazione:

DICHIARAZIONE DI CONFORMITÀ CE

Noi, firmatari della presente, dichiariamo sotto la nostra esclusiva responsabilità, che gli accessori:

serie GLL

al quale questa dichiarazione si riferisce sono conformi alle seguenti norme armonizzate:

- | | |
|---------------------|--------------------|
| - CEI EN 60335-2-40 | - CEI EN 61000-6-1 |
| - | - CEI EN 61000-6-2 |
| - | - CEI EN 61000-6-3 |
| - | - CEI EN 61000-6-4 |

soddisfando così i requisiti essenziali delle seguenti direttive:

- Direttiva Bassa Tensione: LVD 2006/95/CE
- Direttiva Compatibilità Elettromagnetica: EMC 2004/108/CE

The above equipments must be used with AERMEC units FCL series only. Following declaration applies to the combinations as above stated only:

CE CONFORMITY DECLARATION

We the undersigned declare, under our own exclusive responsibility, that the product:

ACCESSORIES GLL series

to which this declaration refers, complies with the following standardised regulations:

- | | |
|-----------------|----------------|
| - EN 60335-2-40 | - EN 61000-6-1 |
| - | - EN 61000-6-2 |
| - | - EN 61000-6-3 |
| - | - EN 61000-6-4 |

thus meeting the essential requisites of the following directives:

- Low Voltage Directive: LVD 2006/95/EC
- Electromagnetic Compatibility Directive: EMC 2004/108/EC

Le présent produit doit être installé, exclusivement, associé avec les unités FCL de notre production.

La certification suivante est valable uniquement si ces associations sont respectées:

CERTIFICAT DE CONFORMITÉ CE

Nous soussignés déclarons sous notre exclusive responsabilité que le produit:

ACCESSOIRES série GLL

auquel cette déclaration fait référence, est conforme aux normes harmonisées suivantes:

- | | |
|-----------------|----------------|
| - EN 60335-2-40 | - EN 61000-6-1 |
| - | - EN 61000-6-2 |
| - | - EN 61000-6-3 |
| - | - EN 61000-6-4 |

satisfaisant ainsi aux conditions essentielles des directives suivantes:

- Directive Basse Tension: LVD 2006/95/CE
- Directive compatibilité électromagnétique: EMC 2004/108/CE

Dieses Produkt darf ausschließlich in Verbindung mit den von AERMEC hergestellten FCL -Einheiten installiert werden. Nachstehende Bescheinigung ist nur dann gültig, wenn folgende Kombinationen vorkommen:

CE KONFORMITÄTSERKLÄRUNG

Wir, die hier Unterzeichnenden, erklären auf unsere ausschließliche Verantwortung, dass das Produkt:

ZUBEHÖR der Serie GLL

auf das sich diese Erklärung bezieht, den folgenden harmonisierten Normen entspricht:

- | | |
|-----------------|----------------|
| - EN 60335-2-40 | - EN 61000-6-1 |
| - | - EN 61000-6-2 |
| - | - EN 61000-6-3 |
| - | - EN 61000-6-4 |

womit die grundlegenden Anforderungen folgender Richtlinien erfüllt werden:

- Niederspannungsrichtlinie: LVD 2006/95/EG
- Richtlinie zur elektromagnetischen Verträglichkeit: EMC 2004/108/EG

El presente producto debe ser instalado exclusivamente en combinación con las unidades FCL de nuestra producción.

Sólo respetando dichas combinaciones será válida la siguiente declaración:

DECLARACIÓN DE CONFORMIDAD CE

Los que suscriben la presente declaran bajo la propia y exclusiva responsabilidad que el conjunto en objeto, definido como sigue:

ACCESORIOS serie GLL

al que esta declaración se refiere, está en conformidad a las siguientes normas armonizadas:

- | | |
|-----------------|----------------|
| - EN 60335-2-40 | - EN 61000-6-1 |
| - | - EN 61000-6-2 |
| - | - EN 61000-6-3 |
| - | - EN 61000-6-4 |

al que esta declaración se refiere, está en conformidad a las siguientes normas armonizadas:

- Directiva de Baja de Tensión: LVD 2006/95/CE
 - Directiva Compatibilidad Electromagnética: EMC 2004/108/CE
- con accesorios no suministrados por Aermec.



NON bagnare. Tenere al riparo dalla pioggia
Do NOT wet
CRAINT l'humidité
Vor Nässe schützen
NO mojar

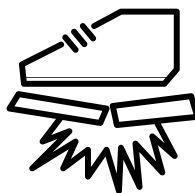

NON calpestare
Do NOT step
NE PAS marcher sur cet emballage
Nicht betreten
NO pisar



Sovrapponibilità: controllare sull'imballo per conoscere il numero di macchine impilabili
Stacking: control the packing to know the number of machines that can be stacked
Empilement: vérifier sur l'emballage pour connaître le nombre d'appareils pouvant être empilés
Stapelung: Die Anzahl der stapelbaren Geräte, wird durch die Symbole auf den Verpackungen ermittelt
Apilamiento: observe en el embalaje para saber cuántos equipos pueden apilarse

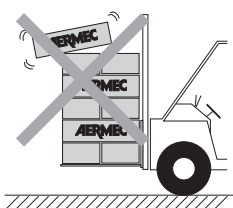

NON lasciare gli imballi sciolti durante il trasporto - Non rovesciare
Do NOT leave loose packages during transport
ATTACHER les emballages pendant le transport
Die Verpackungen nicht ungesichert transportieren
NO lleve las cajas sueltas durante el transporte



NON trasportare la macchina da soli se il suo peso supera i 25 Kg
DO NOT handle the machine alone if its weight is over 25 Kg
NE PAS transporter tout seul l'appareil si son poids dépasse 25 Kg
Das Gerät NICHT alleine tragen, wenn sein Gewicht 25 Kg überschreitet
NO maneje los equipos en solitario si pesan más de 25 kg



Fragile, maneggiare con cura
Fragile, handle with care
Fragile, manipuler avec soin
Zerbrechlich, mit Sorgfalt behandeln
Frágil, manejar con cuidado

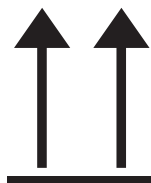

Freccia: alto
Arrow: high
flèche: haut
Pfeil: hoch
Flecha: alto

SIMBOLI DI SICUREZZA • SAFETY SYMBOL • SIMBOLES DE SECURITE
SICHERHEITSSYMBOL • SÍMBOLOS DE SEGURIDAD



Pericolo:
Tensione
Danger:
Power supply
Danger:
Tension
Gefahr !
Spannung
Peligro:
Tensión



Pericolo:
Organi in movimento
Danger:
Movings parts
Danger:
Organes en mouvement
Gefahr !
Rotierende Teile
Peligro:
Elementos en movimiento



Pericolo!!!
Danger!!!
Danger!!!
Gefahr!!!
Peligro!!!

INDEX

Description • Functioning	14
Louvered fin position	15
Information regarding installation	16
Installation and replacement of the GLL10 filter	17
Installation and replacement of the GLL20 filter	19
Electric connections	21
Dimensions	46

DESCRIPTION

The FCL units are available in two fundamental dimensions, which will be called:

"Module 600" for units that can be integrated in the standard 600x600mm suspended ceiling panelling.

"Module 840" for more powerful versions, dimensioned to be housed in a compartment measuring 840x840mm.

INTAKE AND FLOW GRID UNIT (GLL range accessories)

The FCL cassette type fan coil is only completed if coupled to a GLL series grid; a mandatory accessory for fan coil functioning. The GLL series grid accessories, as well as intake with filter

and the air flow louvered fins, include a dedicated electric box, which is connected using bayonet joints to the connector, fixed to the unit support structure.

The form and opening of the flow louvered fins were developed in order to have the best possible distribution of the air, both when functioning in winter and summer modes.

Intake takes place through the central grid, flow through the adjustable perimeter slots. In RAL 9010 plastic, it houses the air filter, which can be easily extracted for cleaning.

The same basic FCL unit can be configured in several versions by simply cou-

pling it to different grid units of the GLL series (mandatory accessory), which determine the functioning modes.

FILTERING SECTION

The air filter is inserted in the intake grid. Mechanical air filter with ABS frame.

Filter with G1 filtering class, self-extinguishing class V0 (UL94).

Easy to remove and built with regenerable materials and which can be washed.

FUNCTIONING

The same GLL grid unit can be coupled to several control panels (accessories) that determine different functioning modes.

The particular information regarding use is supplied in the "USER MANUAL" of the control panels.

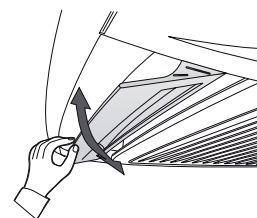
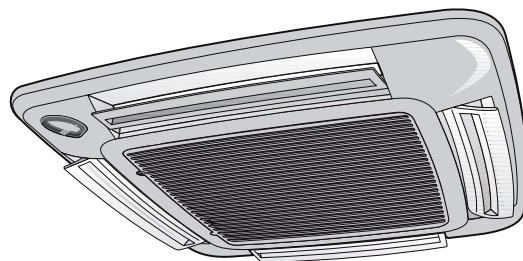

Louvered fin position (GLL10)

In heating functioning mode, a louvered fin opening of 20° is recommended, indicated with a raised line on the louvered fins (see figure).

In cooling functioning mode, a louvered fin opening of 10° is recommended, indicated with a raised line on the louvered fins (see figure).

Ventilation is allowed with the louvered fins closed.

Position of the louvered fins in heating mode
20° opening

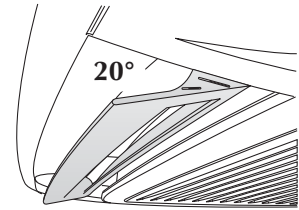

Position of the louvered fins in cooling mode
10° opening

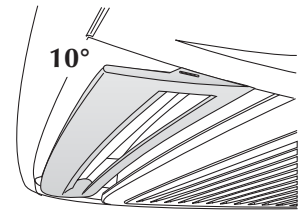

Ventilation is allowed with the louvered fins closed

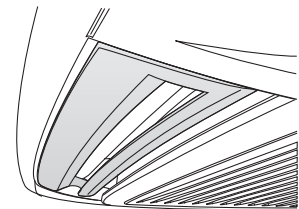

English

Louvered fin position (GLL20)

Complete louvered fin opening is recommended in heating functioning mode (see figure).

In cooling functioning mode louvered fin opening of 50% is recommended (see figure).

Ventilation is allowed with the louvered fins closed.

Position of the louvered fins in heating mode
completely open

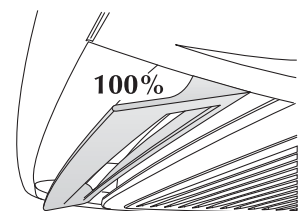

Position of the louvered fins in cooling mode
half-way opening

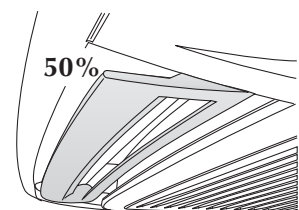

Ventilation is allowed with the louvered fins closed

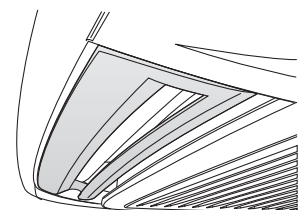

INSTALLATION

ATTENTION: before carrying out any intervention, make sure that the electric power supply has been disconnected.

CAUTION: before carrying out any work, wear the appropriate individual protection devices.

ATTENTION: The appliance must be installed in compliance with national regulations on this subject.

ATTENTION: the electric connections, the installation of the fan coils and their accessories must only be performed by subjects with the technical-professional requisites for enabling and installation, transformation, extension and maintenance of the systems and able to check the same for safety and functionality purposes (in this manual they will be indicated by the generic term "staff with specific technical skill").

In particular, for the electric connections, checks relative to the following are requested:

- Measurement of the electric plant isolation resistance.
- Continuity test of the protection wires.

ATTENTION: Install a device, master switch or electric plug that allows to completely interrupt the appliance's electric power supply.

Here find the essential indications for correct installation of the appliance.

The completion of all operations, according to specific requirements, is left to the experience of the installer.

Also consult the FCL installation manual and the user manual supplied with the grid unit.

Generally the best position of the louvered fins is that that allows the launch of the air adhering to the ceiling for the coined effect, during cold functioning.

The side section of the deflectors (GLL10) shows the opening positions for proper warm functioning (opening 20°) and cold functioning (opening 10°) of the machine.

For the units with GLL20 grids, it is recommended to completely open the deflector in heating mode. In cooling mode, rotate the deflector to half way.

Depending on the user's requirements, it is possible to position the louvered fins

in the intermediate of complete closure positions. Thanks to the special shapes of the louvered fins the machine can also function with the deflectors completely closed.

Do not install at height of above three metres.

The FCL unit is set for connection with fresh air ducts and for the flow of the treated air in an adjacent room.

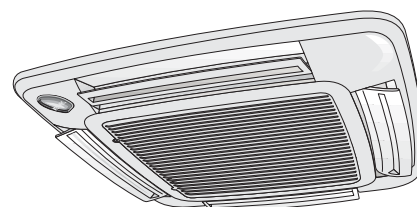

• INSTALLATION IN PROXIMITY OF A WALL

In caso di installazione in prossimità di una parete è possibile chiudere la corrispondente bocchetta di mandata con la guarnizione fornita a corredo.

If installed in proximity of a wall it is possible to close the corresponding flow inlet using the gasket supplied.

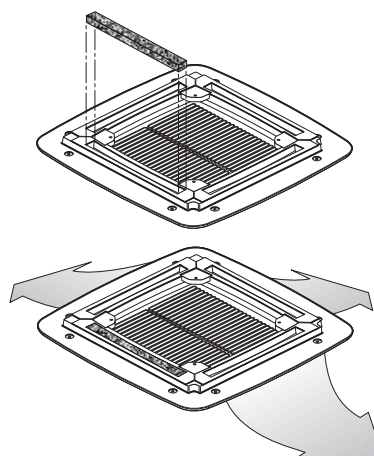

"GLL10" INSTALLATION

- Open the packaging of the accessory, flow frame and intake grid unit, remove the grid from the packaging and check that it has not been damaged during transport.
- Open the cover of the terminal board on the electric box. Use a tool to release the pressurised hooks.
- Connect the power supply cables to the terminal board as indicated in the wiring diagram.
- Fix all cables using the cable gland.
- Close the cover of the electric terminal board.
- Insert the electric box into the FCL unit guide and make sure that the connectors are well attached.
- The electric box must be fixed to the FCL unit using two screws. The screw on the attachment side is also used to fix the supplied safety cable.

ATTENTION: fix the safety cable to the electric box screw fastener positioned at the side of the hydraulic connections. The safety cable snap

hook must then be attached to the grid frame.

- Remove the intake grid by acting on the 2 ratchets by $\frac{1}{4}$ of a turn.
- To make fixing of the frame to the fan coil easier, insert two support hooks to the relevant pegs on the conveyor.
- Hang the frame on the two support hooks, **pay attention to the assembly position, the corner of the frame with the AERMEC logo holder must coincide with the corner of the FCL unit electric box.**
- **ATTENTION: fix the safety cable to the frame.**
- Connect the receiver connection cable to the connector on the circuit board box.
- Fix the frame to the unit using the 4 screws supplied.

CAUTION!! tighten the screws with maximum coupling torque of 0.45 Nm. It is advised to use a screwdriver, do not use non calibrated electric screwdrivers. An excessive coupling

torque will damage the tray irreparably.

The frame guarantees sealing between air intake and flow, therefore, it must be fixed correctly to the unit without undergoing deformations.

- Fix the intake grill to the safety cable.
- Mount the intake grid, hooking it to the hinge on the frame.
- Close the intake grid and tighten the two ratchets (on the side opposite the hinge) by $\frac{1}{4}$ of a turn.
- Adjust the position of the unit by the support bracket by means of the nuts, in a way that the unit is level and the frame rests slightly in the suspended ceiling.
- Start the fan coil and carry out a functioning test.

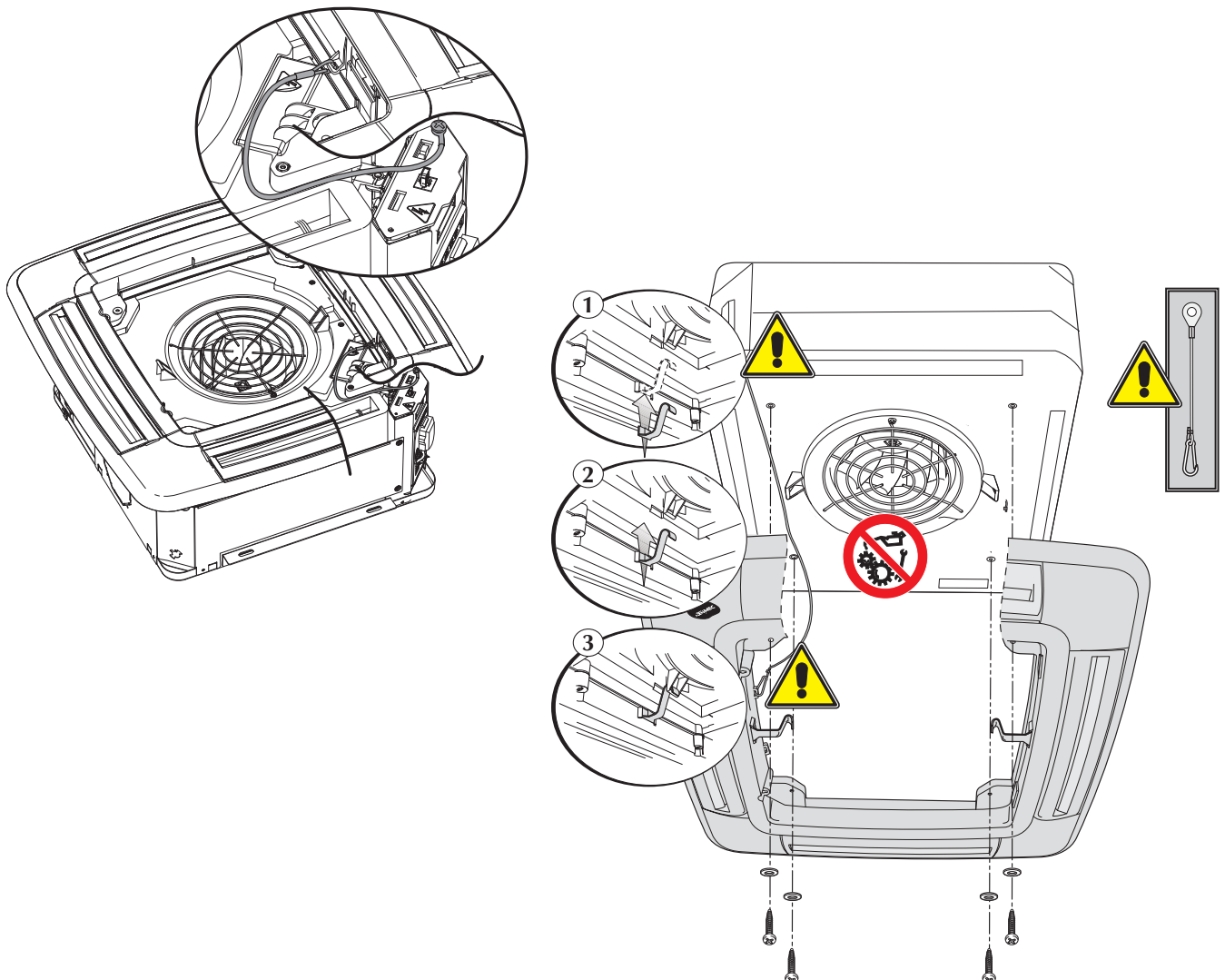

INSTALLATION AND REPLACEMENT OF THE "GLL10" FILTER

English

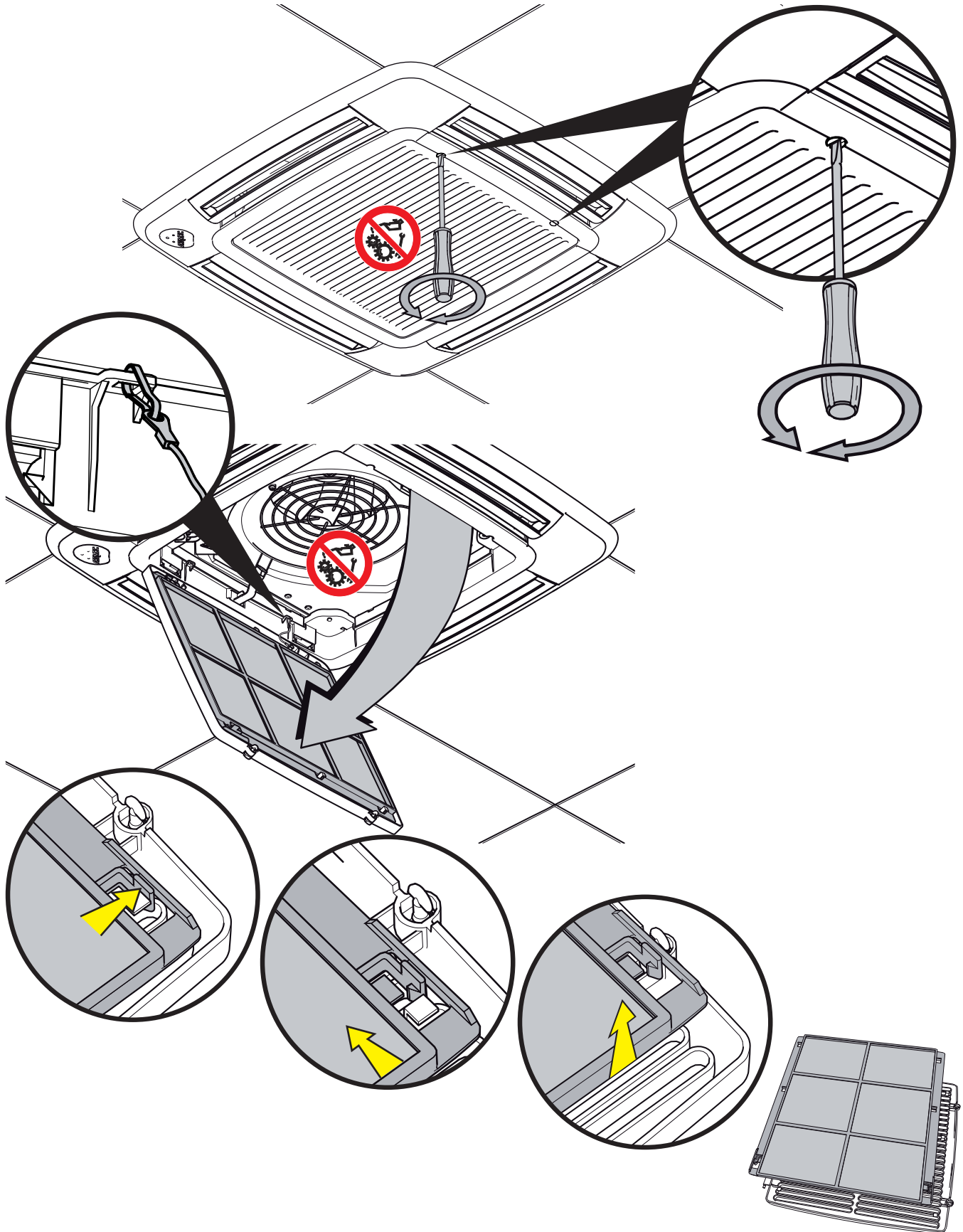

PERICOLO: Togliere tensione prima d'iniziare le operazioni di pulizia del filtro e/o dell'unità.
DANGER: Switch off power supply before cleaning filter and/or unit.
DANGER: Couper la tension avant de commencer les opérations de nettoyage du filtre et/ou de l'unité.
GEFAHR: Vor der Reinigung des Filters und/oder des Gerätes die Stromversorgung abschalten.
PELIGRO: Quitar la tensión antes de iniciar las operaciones de limpieza del filtro o de la unidad.

INSTALLATION OF THE "GLL20" UNIT

- Open the packaging of the accessory, flow frame and intake grid unit, remove the grid from the packaging and check that it has not been damaged during transport.
- Open the cover of the terminal board on the electric box. Use a tool to release the pressurised hooks.
- Connect the power supply cables to the terminal board as indicated in the wiring diagram.
- Fix all cables using the cable gland.
- Close the cover of the electric terminal board.
- Insert the electric box into the FCL unit guide and make sure that the connectors are well attached.
- The electric box must be fixed to the FCL unit using two screws.
- Remove the intake grid by acting on the 2 ratchets by $\frac{1}{4}$ of a turn.
- Hang the frame on the two support hooks, pay attention to the assembly position, **the corner of the frame with the AERMEC logo holder must coincide**

with the corner of the FCL unit electric box.

- **ATTENTION: fix a safety cable snap hook must then be attached to the grid frame and the other snap hook to the fan protection grid.**

- Fix the frame to the unit using the 4 screws supplied.

CAUTION!! tighten the screws with maximum coupling torque of 0.45 Nm. It is advised to use a screwdriver, do not use non calibrated electric screwdrivers. An excessive coupling torque will damage the tray irreparably.

The frame guarantees sealing between air intake and flow, therefore, it must be fixed correctly to the unit without undergoing deformations.

- Fix the intake grill to the safety cable.
- Mount the intake grid, hooking it to the hinge on the frame.
- Close the intake grid and tighten the two ratchets (on the side opposite the hinge) by $\frac{1}{4}$ of a turn.

- Adjust the position of the unit by the support bracket by means of the nuts, in a way that the unit is level and the frame rests slightly in the suspended ceiling.
- Start the fan coil and carry out a functioning test.

Electric box maintenance

If the electric box must be accessed for maintenance, follow the indications below:

- Open the filter grid (turn the two ratchets by $\frac{1}{4}$ of a turn).
- Remove the lock screw on the corner door with the Aermec logo.
- Remove the 2 lock screws from the electric box.
- Slide the electric box downwards.
- Carry out the necessary maintenance.
- Re-mount everything performing the disassembly procedure in reverse order.

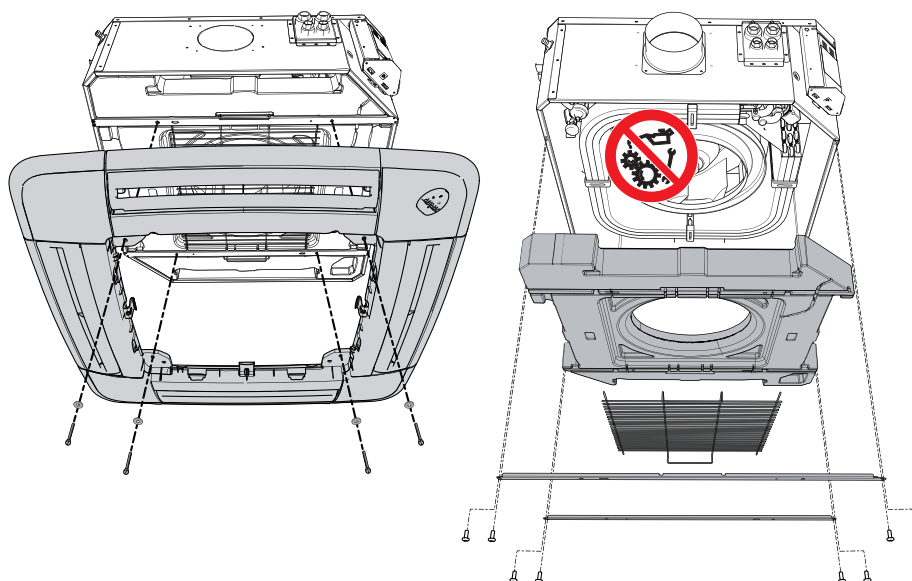
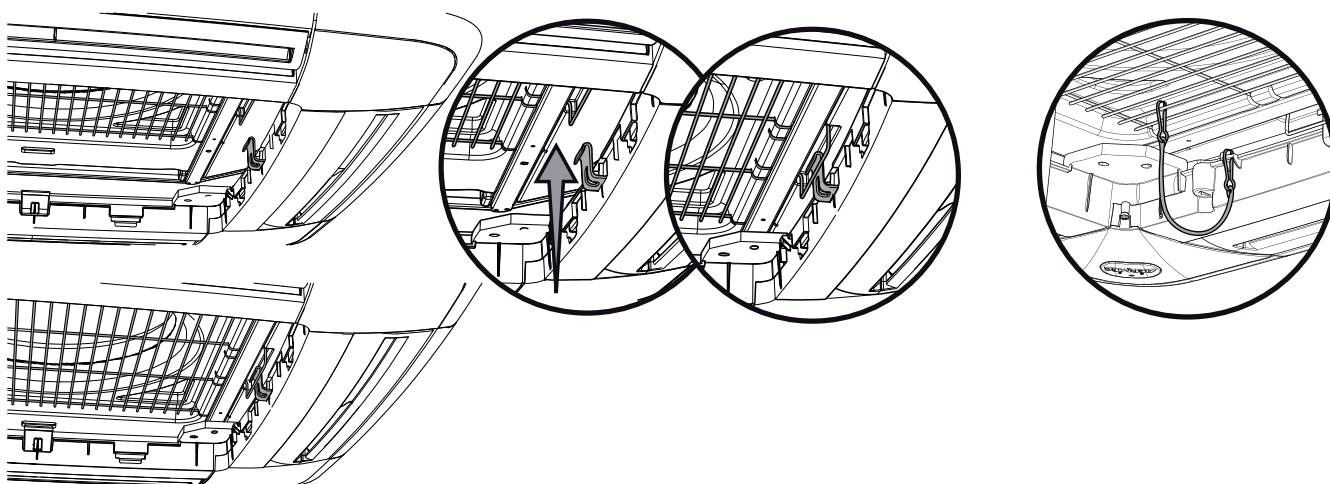

• Disassembly for maintenance

- Before performing any operation on the unit, the electric power supply must be interrupted.
- To access the inside of the unit, remove the two cross-members fixed to the frame with the screws. It is now possible to remove the fan protection grid and the polystyrene basin. (see figure)
- **DANGER!!** Before re-applying voltage to the unit, all components, especially the protection grid, must have been re-mounted correctly.

INSTALLATION AND REPLACEMENT OF THE "GLL20" FILTER

English

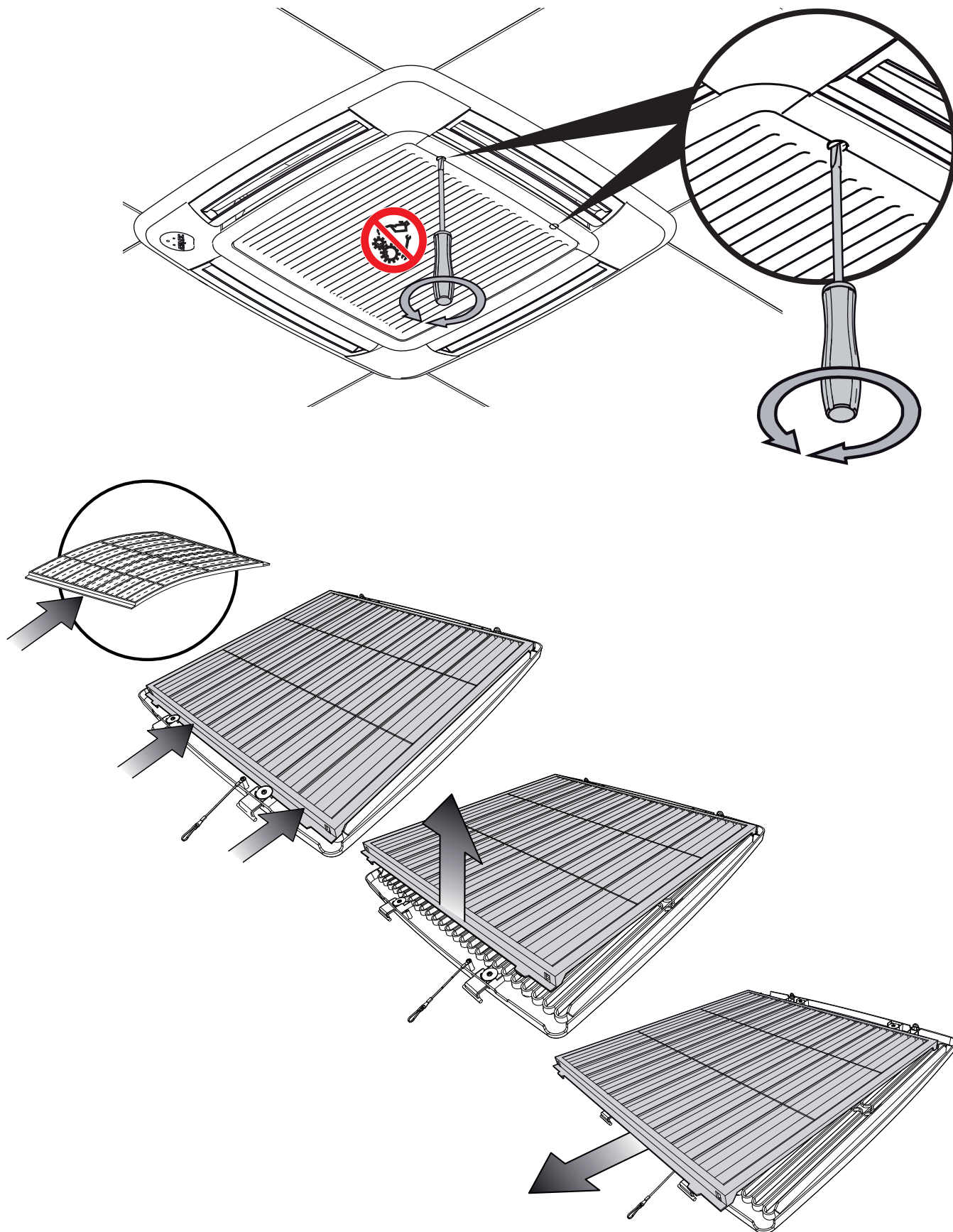

PERICOLO: Togliere tensione prima d'iniziare le operazioni di pulizia del filtro e/o dell'unità.
DANGER: Switch off power supply before cleaning filter and/or unit.
DANGER: Couper la tension avant de commencer les opérations de nettoyage du filtre et/ou de l'unité.
GEFAHR: Vor der Reinigung des Filters und/oder des Gerätes die Stromversorgung abschalten.
PELIGRO: Quitar la tensión antes de iniciar las operaciones de limpieza del filtro o de la unidad.

ELECTRIC CONNECTIONS

The unit must be connected directly to an electrical outlet or to an independent circuit.

The FCL cassette fan coils must be powered with 230V ~ 50Hz current and have an earth connection. The line voltage must remain within the tolerance of $\pm 10\%$ with respect to the nominal value.

In order to protect the unit against short circuits, mount a max.2A 250V (IG) magnet circuit breaker omnipolar switch on the power supply line with a minimum contact opening distance of 3 mm.

The electrical power supply cable must be of the H07 V-K or N07 V-K type with 450/750V insulation if inside a tube or raceway. Use cables with double H5VV-F type insulation for visible cable installation.

Refer to the wiring diagrams of the appliance and the control panel.

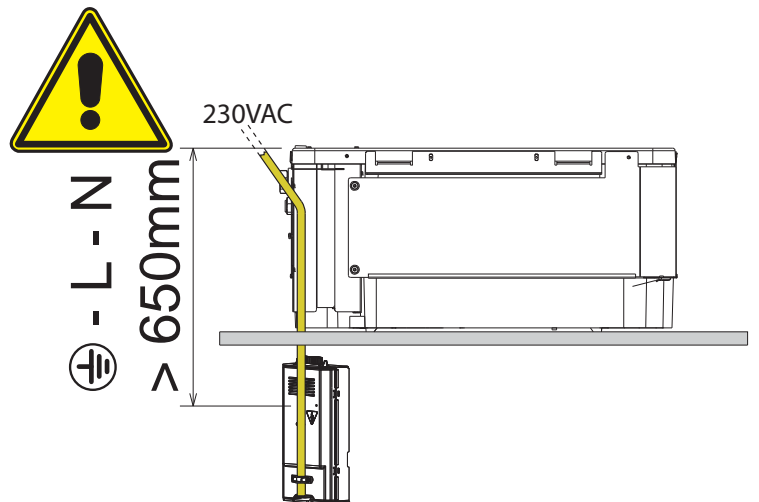
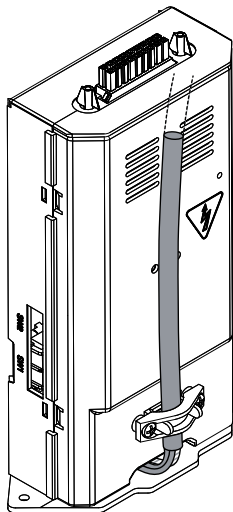
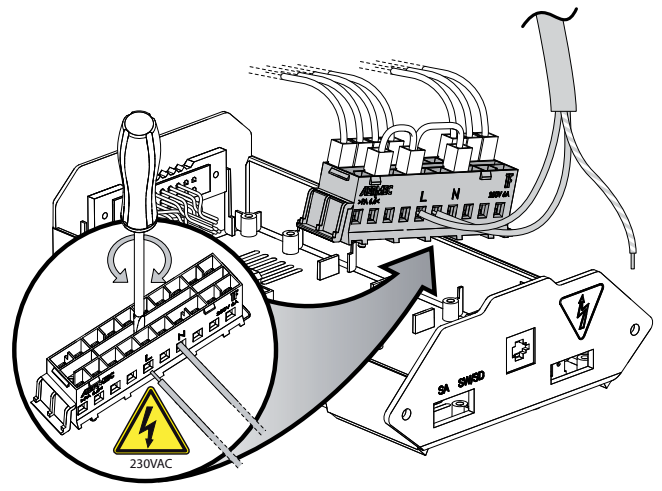
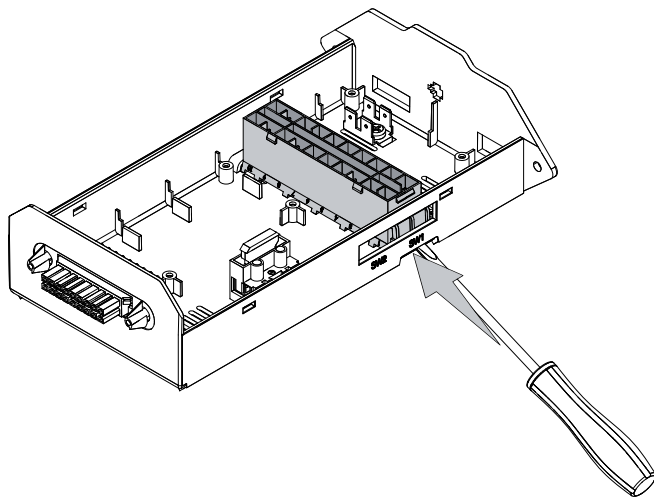
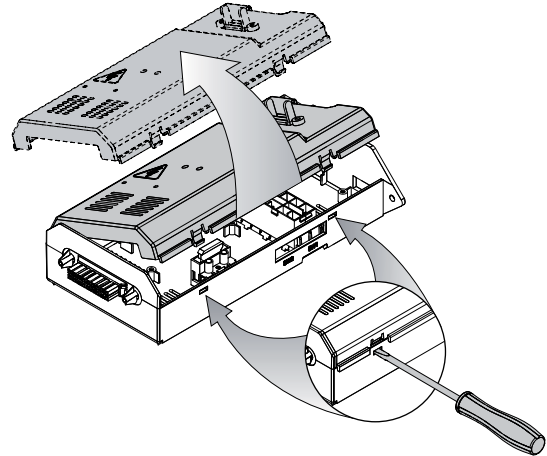
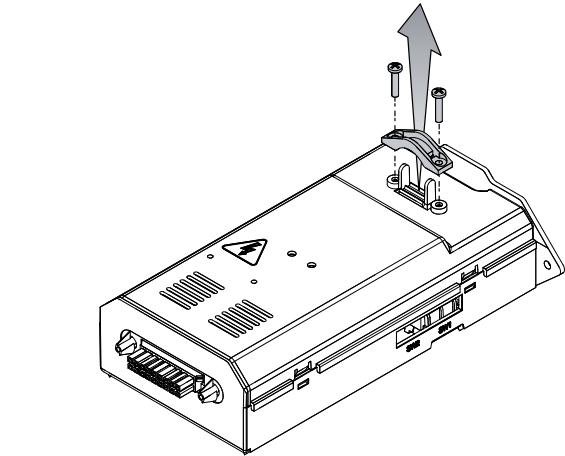
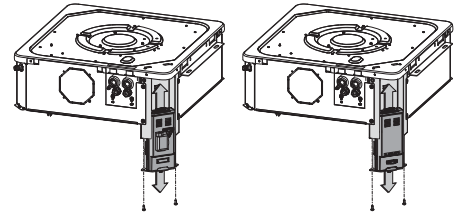

GLL10

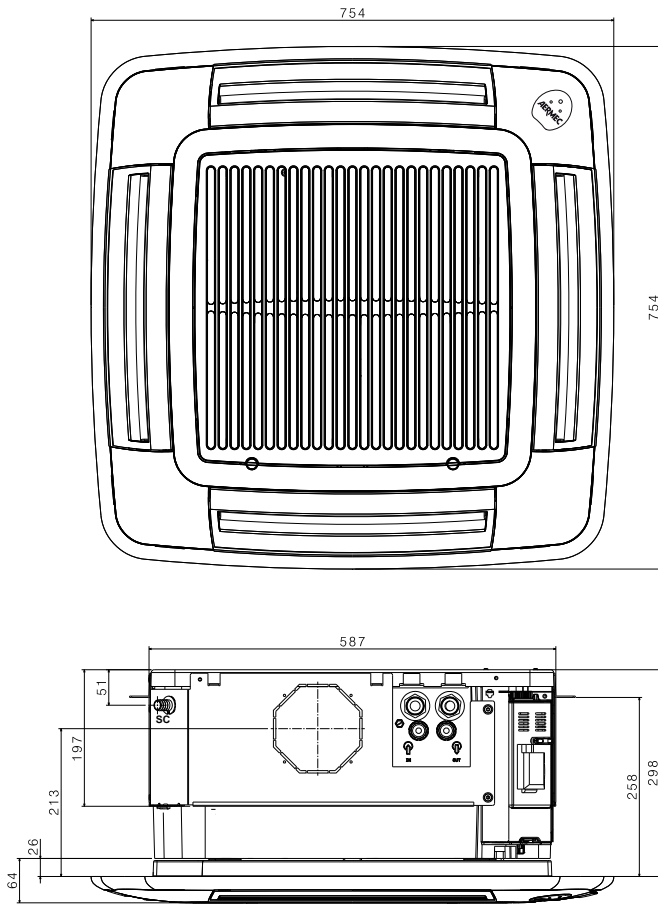

GLL20

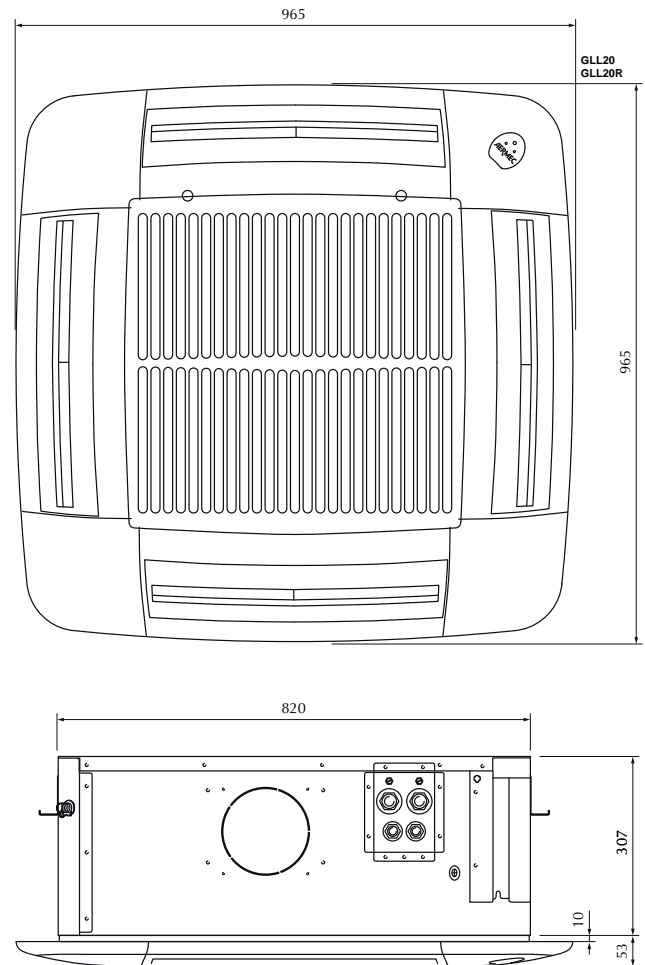



Aermec partecipa al Programma di Certificazione EUROVENT. I prodotti interessati figurano nella Guida EUROVENT dei Prodotti Certificati.

Aermec is participating in the EUROVENT Certification Programme. Products are as listed in the EUROVENT Directory of Certified Products.

Aermec partecipe au Programme de Certification EUROVENT. Les produits figurent dans l'Annuaire EUROVENT des Produits Certifiés.

Aermec ist am Zertifikations - Programm EUROVENT beteiligt. Die entsprechend gekennzeichneten Produkte sind im EUROVENT - Jahrbuch aufgeführt.

AERMEC S.p.A. participa en el programa de certificación EUROVENT. Sus equipos aparecen en el directorio de productos certificados EUROVENT.

I dati tecnici riportati nella presente documentazione non sono impegnativi.

AERMEC S.p.A. si riserva la facoltà di apportare in qualsiasi momento tutte le modifiche ritenute necessarie per il miglioramento del prodotto.

Les données mentionnées dans ce manuel ne constituent aucun engagement de notre part. Aermec S.p.A. se réserve le droit de modifier à tous moments les données considérées nécessaires à l'amélioration du produit.

Technical data shown in this booklet are not binding.

Aermec S.p.A. shall have the right to introduce at any time whatever modifications deemed necessary to the improvement of the product.

Im Sinne des technischen Fortschrittes behält sich Aermec S.p.A. vor, in der Produktion Änderungen und Verbesserungen ohne Ankündigung durchzuführen.

Los datos técnicos indicados en la presente documentación no son vinculantes.

Aermec S.p.A. se reserva el derecho de realizar en cualquier momento las modificaciones que estime necesarias para mejorar el producto.

AERMEC S.p.A.

I-37040 Bevilacqua (VR) - Italia

Via Roma, 44 - Tel. (+39) 0442 633111

Telefax (+39) 0442 93730 - (+39) 0442 93566

www.aermec.com