

**VENTILCONVETTORI
FAN COIL
VENTILO-CONVECTEURS
GEBLÄSEKONVEKTOREN
FAN COIL**

FCS – A



IFCSALJ
0507
64560.95_00

AERMEC

AERMEC S.p.A.

I-37040 Bevilacqua (VR) Italia – Via Roma, 44

Tel. (+39) 0442 633111

Telefax (+39) 0442 93730 – (+39) 0442 93566

www.aermec.com - info@aermec.com

FCS-A

DICHIARAZIONE DI CONFORMITÀ

Noi, firmatari della presente, dichiariamo sotto la nostra esclusiva responsabilità, che la macchina in oggetto è conforme a quanto prescritto dalle seguenti Direttive:

- Direttiva macchine 98/37 CEE;
- Direttiva bassa tensione 73/23 CEE;
- Direttiva compatibilità elettromagnetica EMC 89/36 CEE.

DECLARATION OF CONFORMITY

We declare under our own responsibility that the above equipment complies with provisions of the following Standards:

- Equipment Standard 98/37 EEC;
- Low voltage Standard 73/23 EEC;
- Electromagnetic compatibility Standard EMC 89/36 EEC.

CERTIFICAT DE CONFORMITE

Nous, signataires de la présente, certifions sous notre propre responsabilité, que l'appareil en objet est conforme aux suivantes Directives:

- Directive appareil 98/37 EEC;
- Directive basse tension 73/23 EEC;
- Directiva compatibilità elettromagnetica EMC 89/36 EEC.

KONFORMITÄTSEKTLÄRUNG

Wir, Unterzeichner dieser Bescheinigung, bestätigen, daß diese Geräte den Vorschriften:

- Vorschrift Geräte 98/37 EWG;
- Niederspannung - Vorschrift 73/23 EWG;
- Funkentstörung - Vorschrift EMC 89/36 EWG.

DECLARACION DE CONFORMIDAD

Declaramos bajo nuestra responsabilidad que los equipos arriba indicados cumplen con las siguientes directivas:

- Directiva de máquinas 98/37;
- Baja tensión 73/23 CEE;
- Compatibilidad electromagnética (CEM) 89/36 CEE.

Bevilacqua, 01/06/2005

La Direzione Commerciale - Sales and Marketing Director

LUIGI ZUCCHI

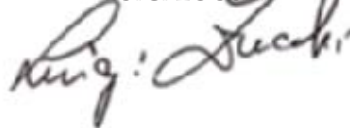

EUROVENT
CERTIFIED PERFORMANCE



Aermecc partecipa al Programma di Certificazione EUROVENT. I prodotti interessati figurano nella Guida EUROVENT dei Prodotti Certificati.

Aermecc is participating in the EUROVENT Certification Programme. Products are as listed in the EUROVENT Directory of Certified Products.

Aermecc partecipe au Programme de Certification EUROVENT. Les produits figurent dans l'Annuaire EUROVENT des Produits Certifiés.

Aermecc ist am Zertifikations - Programm EUROVENT beteiligt. Die entsprechend gekennzeichneten Produkte sind im EUROVENT - Jahrbuch aufgeführt.

AERMECC S.p.A. participa en el programa de certificación EUROVENT. Sus equipos aparecen en el directorio de productos certificados EUROVENT.

INDICE • CONTENTS • INDEX • INHALTSVERZEICHN • ÍNDICE

USI IMPROPRI • IMPROPER USES • ENTRETIEN

UNSACHGEMÄßER GEBRAUCH • USOS INCORRECTOS

3

MISURE DI SICUREZZA • SAFETY MEASURES • MISURES DE SECURITE • SICHERHEITSMABNAHMEN

Simboli di sicurezza • *Safety symbol* • Simboles de securite • *Sicherheitssymbole* • Símbolos de seguridad 4

FUNZIONAMENTO • OPERATION • FONCTIONNEMENT • BETRIEB • FUNCIONAMIENTO

CARATTERISTICHE • FEATURES • CARACTERISTIQUES • EIGENSCHAFTEN • CARACTERISTICAS

Dati dimensionali • *Dimensions* • Dimensions • *Abmessungen* • Dimensiones 6

Schemi elettrici • *Wiring diagrams* • Schemas électriques • *Schaltplane* • Esquemas eléctricos 9

INSTALLAZIONE • INSTALLATION • INSTALACION

Imballo • Installazione dell'unità • Collegamenti elettrici • Rotazione batteria 10

Informazioni importanti e manutenzione 11

Packing • Unit installation • Electrical connections • Rotating the coil 12

Important maintenance information 13

Emballage • Installation de l'unité • Raccordements électriques • Rotation de la batterie 14

Information importantes sur la maintenance 15

Verpackung • Installation des Gerätes • Elektrische anschlüsse • Idrehen der batterie 16

Wichtige hinweise und Wartung 17

Embalaje • Instalación de la unidad • Conexiones eléctricas • Rotación de la batería 18

Informaciones importantes y mantenimiento 19

SERVIZIO ASSISTENZA TECNICA IN ITALIA 23

USI IMPROPRI • IMPROPER USES • USAGES IMPROPRES • UNSACHGEMÄßER GEBRAUCH • USOS INCORRECTOS

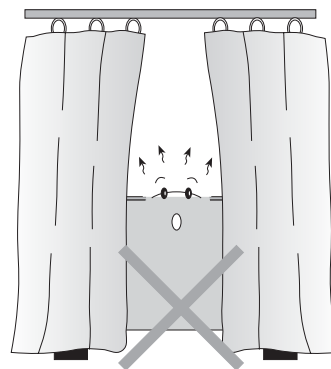
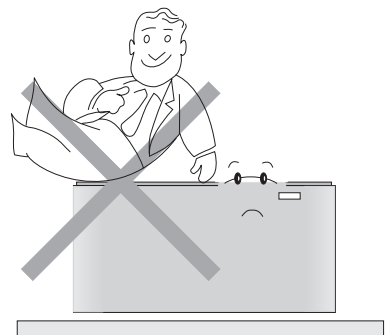
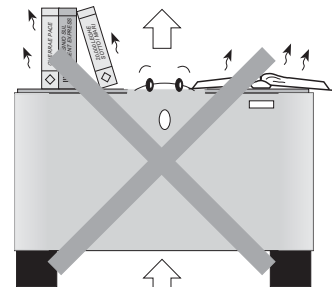
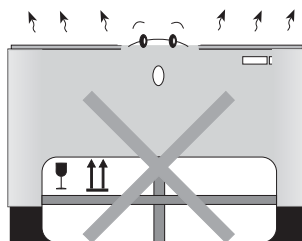
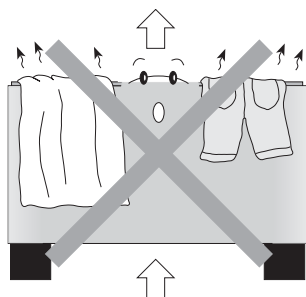

PERICOLO: Togliere tensione prima d'iniziare le operazioni di pulizia del filtro e/o dell'unità.

DANGER: Switch off power supply before cleaning filter and/or unit.

DANGER: Couper la tension avant de commencer les opérations de nettoyage du filtre et/ou de l'unité.

GEFAHR: Vor der Reinigung des Filters und/oder des Gerätes die Stromversorgung abschalten.

TRASPORTO • CARRIAGE • TRANSPORT • TRANSPORT • TRANSPORTE

NON bagnare • *Do NOT wet*
CRAINT l'humidité • *Vor Nässe schützen*
NO mojar



NON calpestare • *Do NOT trample*
NE PAS marcher sur cet emballage • *Nicht betreten*
NO pisar

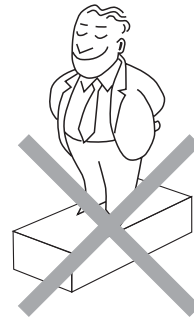

Sovrapponibilità: controllare sull'imballo la posizione della freccia per conoscere il numero di macchine impilabili.

Stacking: control the packing for the arrow position to know the number of machines that can be stacked.

Empilement: vérifier sur l'emballage la position de la flèche pour connaître le nombre d'appareils pouvant être empilés.

Stapelung: Anhand der Position des Pfeiles an der Verpackung kontrollieren, wieviele Geräte stapelbar sind.

Apilamiento: observe en el embalaje la posición de la flecha para saber cuántos equipos pueden apilarse.

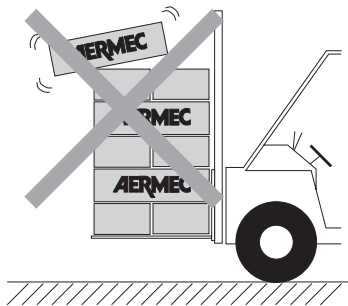
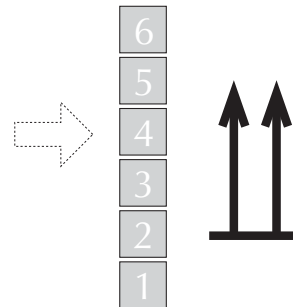

NON lasciare gli imballi sciolti durante il trasporto.

Do NOT leave loose packages during transport.

ATTACHER les emballages pendant le transport.

Die Verpackungen nicht ungesichert transportieren.

NO lleve las cajas sueltas durante el transporte.

NON trasportare la macchina da soli se il suo peso supera i 35 Kg.

DO NOT handle the machine alone if its weight is over 35 Kg.

NE PAS transporter tout seul l'appareil si son poids dépasse 35 Kg.

Das Gerät NICHT alleine tragen, wenn sein Gewicht 35 Kg überschreitet.

NO maneje los equipos en solitario si pesan más de 35 kg.

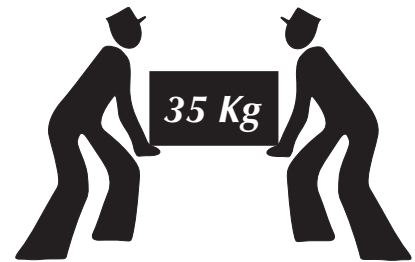

SIMBOLI DI SICUREZZA • SAFETY SYMBOL • SIMBOLES DE SECURITE
SICHERHEITSSYMBOL • SIMBOLOS DE SEGURIDAD

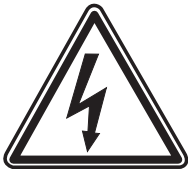

Pericolo:
Tensione

Danger:
Power supply

Danger:
Tension

Gefahr!
Spannung

Peligro:
Tensión



Pericolo:

Organi in movimento

Danger:
Movings parts

Danger:
Organes en mouvement

Gefahr!
Rotierende Teile

Peligro:
Elementos en movimiento



Pericolo!!!

Danger!!!

Danger!!!

Gefahr!!!

Peligro!!!

Commutatore manuale (versione A)
Manual switch (A version)
Commande standard (version A)
Standard Fernbedienung (version A)
Conmutador manual (versión A)

a) Per accendere/spegnere il ventilconvettore:
Commutare la posizione del selettore superiore.

To turn on/off the fan coil:
Shift the upper button. On the remote panel with

Pour allumer/eteindre le ventilconvecteur:
Pousser le bouton du haut. Sur le panneau avec

Einschalten/Ausschalten des Gebläsekonvektors:
Die Stellung des oberen Schiebers ändern. Auf der mit

Para encender o apagar el fan coil:
Cambie de posición el selector superior.

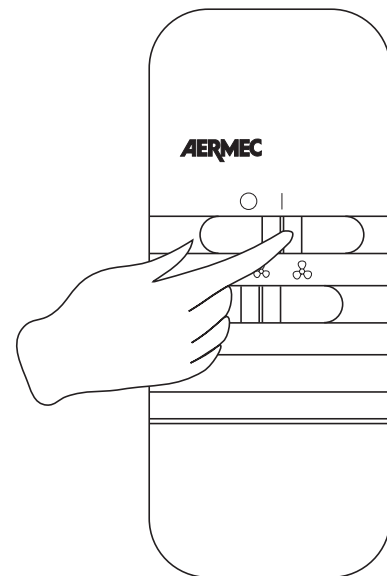

b) Per scegliere la velocità del ventilatore

To select fan coil speed

Pour choisir la vitesse du ventilateur

Ventilatorgeschwindigkeit wählen

Para elegir la velocidad del ventilador

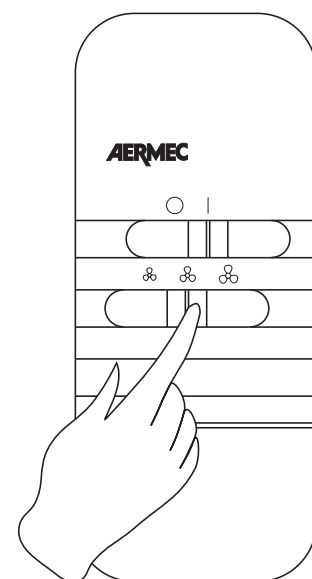

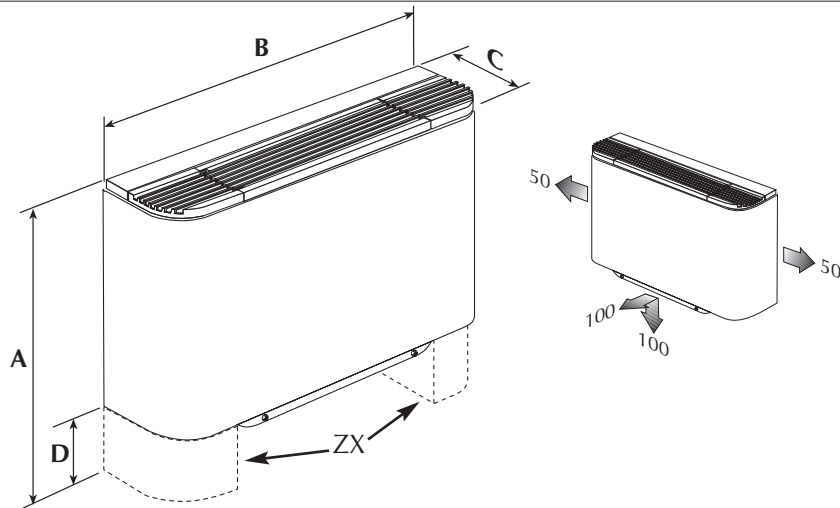

Mod.	FCS 22	FCS 32	FCS 42	FCS 50	FCS 62	FCS 82
A	563	563	563	563	688	688
B	750	980	1200	1200	1320	1320
C	105	105	105	105	125	125
Peso Weight Poids [Kg] Gewicht Peso	15	20	24	24	34	34

Peso ventilconvettore senza zoccoli (ZX) • Weight of fan coil without (ZX) feet
 Poids ventilo-convecteur sans pieds (ZX) • Gewicht Gebläsekonvektor ohne Sockel (ZX) • Peso del fan coil sin zócalos (ZX)

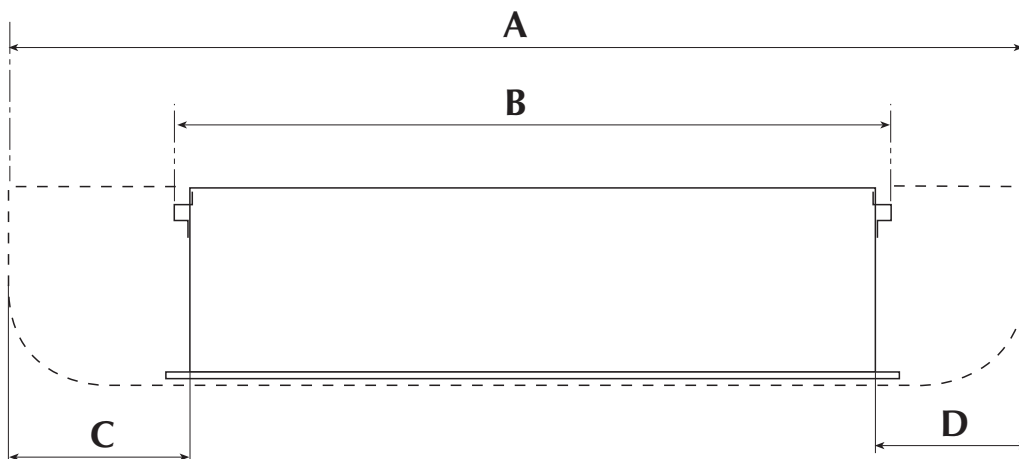

Mod.	FCS 22	FCS 32	FCS 42	FCS 50	FCS 62	FCS 82
A	750	981	1201	1201	1322	1322
B	555	786	1006	1006	1127	1127
C	144,5	144,5	144,5	144,5	144,5	144,5
D	103,5	103,5	103,5	103,5	103,5	103,5

In caso di inversione degli attacchi idraulici, scambiare tra loro le seguenti quote: C con D.

In case of inversion hydraulic connections, invert C with D.

En cas d'inversion des raccords hydrauliques, inverser les cotes C avec D.

Bei der Anschlußenumstellung, die Quoten C und D, miteinander auswechseln.

Si desea invertir el lado de las conexiones hidráulicas, intercambie C por D.

FCS 22 - 32 - 42 - 50

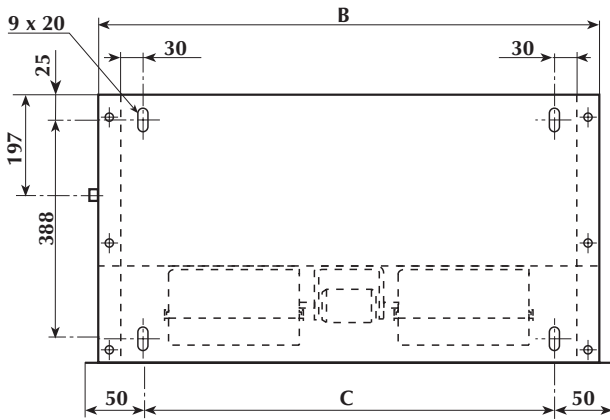

3 R

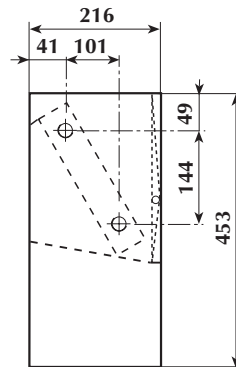

3 R + 1 R

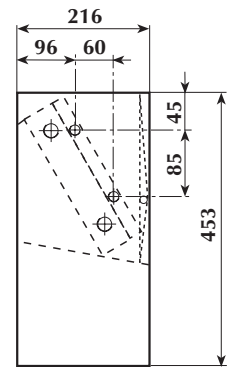

FCS 62 - 82

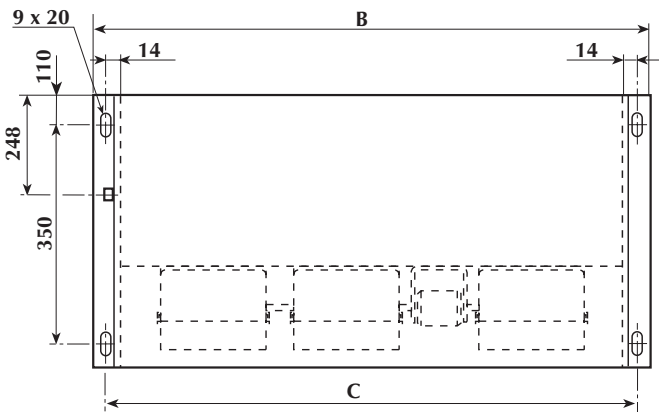

3 R

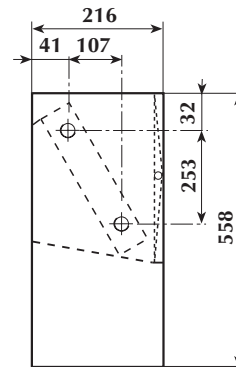

3 R + 1 R

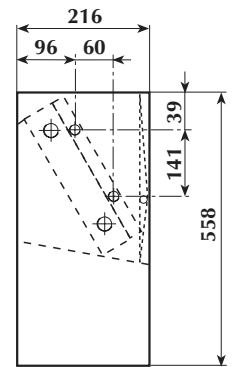

Mod.	FCS 22	FCS 32	FCS 42	FCS 50	FCS 62	FCS 82
B	522	753	973	973	1122	1122
C	440	671	891	891	1102	1102

Attacchi batteria (femmina) • Coil connection (female)
 Raccords batterie (femelle) • Anschlüsse des Wärmetauschers (Innengewinde)
 Conexiones de la batería (hembra)

Mod.	FCS 22	FCS 32	FCS 42	FCS 50	FCS 62	FCS 82
3 R	1/2"	1/2"	1/2"	1/2"	3/4"	3/4"
1 R	1/2"	1/2"	1/2"	1/2"	1/2"	1/2"

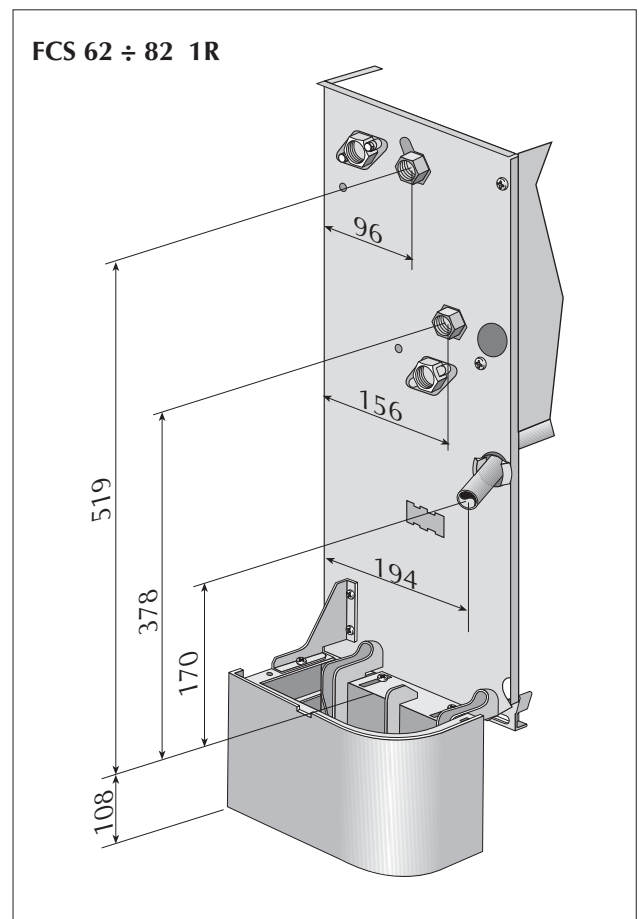
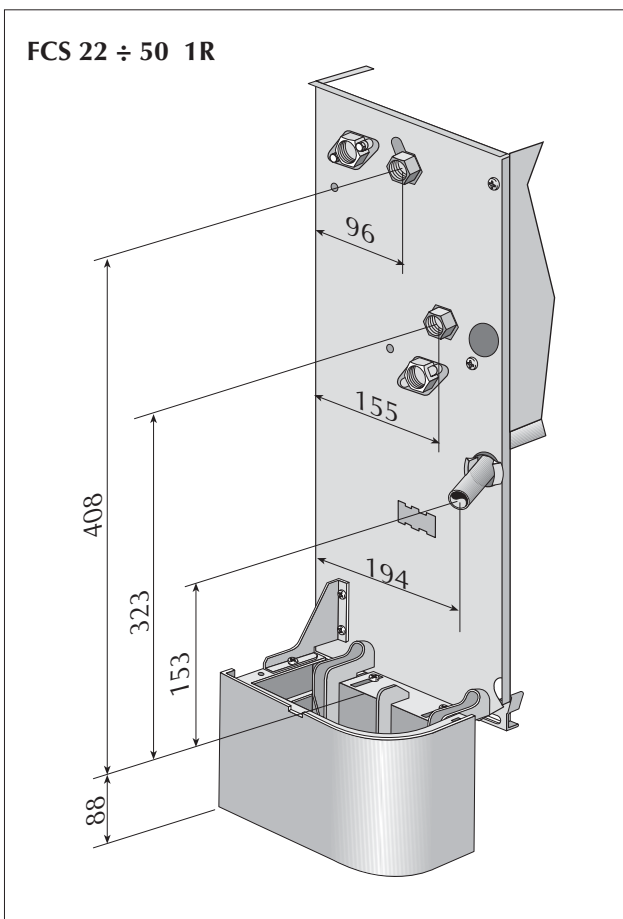
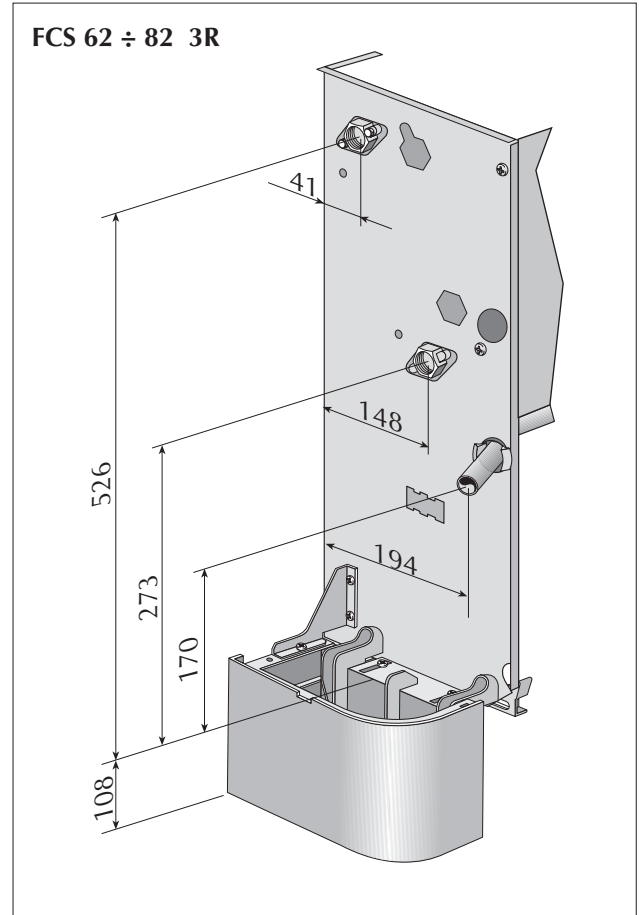
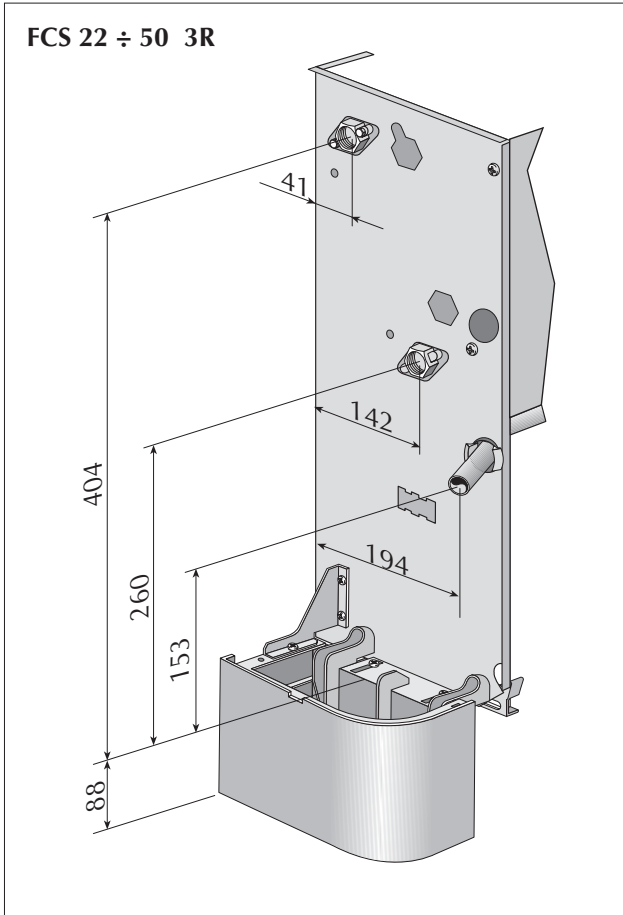

LEGENDA • READING KEY • LEGENDE • LEGENDE • LEYENDA

- | | |
|---|---|
| IG = Interruttore generale • <i>Main switch</i> • Interrupteur général
<i>Hauptschalter</i> • <i>Interruptor general</i> | - - - = Collegamenti da eseguire in loco
<i>On-site wiring</i>
Raccordements à effectuer in situ
<i>Vor Ort auszuführende Anschlüsse</i>
Cableado in situ |
| M = Morsettiera • <i>Terminal board</i>
<i>Boitier</i> • <i>Klemmleiste</i> • <i>Placa de bornes</i> | AR = Arancio • <i>Orange</i> • <i>Orange</i> • <i>Orange</i> • <i>Naranja</i> |
| MV = Motore ventilatore • <i>Fan motor</i> • Moteur ventilateur
<i>Ventilatormotor</i> • <i>Motor del ventilador</i> | BI = Bianco • <i>White</i> • <i>Blanc</i> • <i>Weiss</i> • <i>Blanco</i> |
| SC = Scheda di controllo • <i>Electronic control board</i>
<i>Platine de contrôle</i> • <i>Steuerschaltkreis</i>
<i>Tarjeta electrónica de control</i> | BL = Blu • <i>Blue</i> • <i>Bleu</i> • <i>Blau</i> • <i>Azul</i> |
|  = Componenti non forniti • <i>Components not supplied</i>
<i>Composants non fournis</i> • <i>Nicht lieferbare Teile</i>
<i>Componentes no suministrados</i> | GR = Grigio • <i>Grey</i> • <i>Gris</i> • <i>Gray</i> • <i>Gris</i> |
| | MA = Marrone • <i>Brown</i> • <i>Marron</i> • <i>Braun</i> • <i>Marrón</i> |
| | NE = Nero • <i>Black</i> • <i>Noir</i> • <i>Schwarz</i> • <i>Negro</i> |
| | RO = Rosso • <i>Red</i> • <i>Rouge</i> • <i>Rot</i> • <i>Rojo</i> |
| | VE = Verde • <i>Green</i> • <i>Vert</i> • <i>Grünv</i> • <i>Verde</i> |
| | VI = Viola • <i>Violet</i> • <i>Violet</i> • <i>Violet</i> • <i>Violeta</i> |

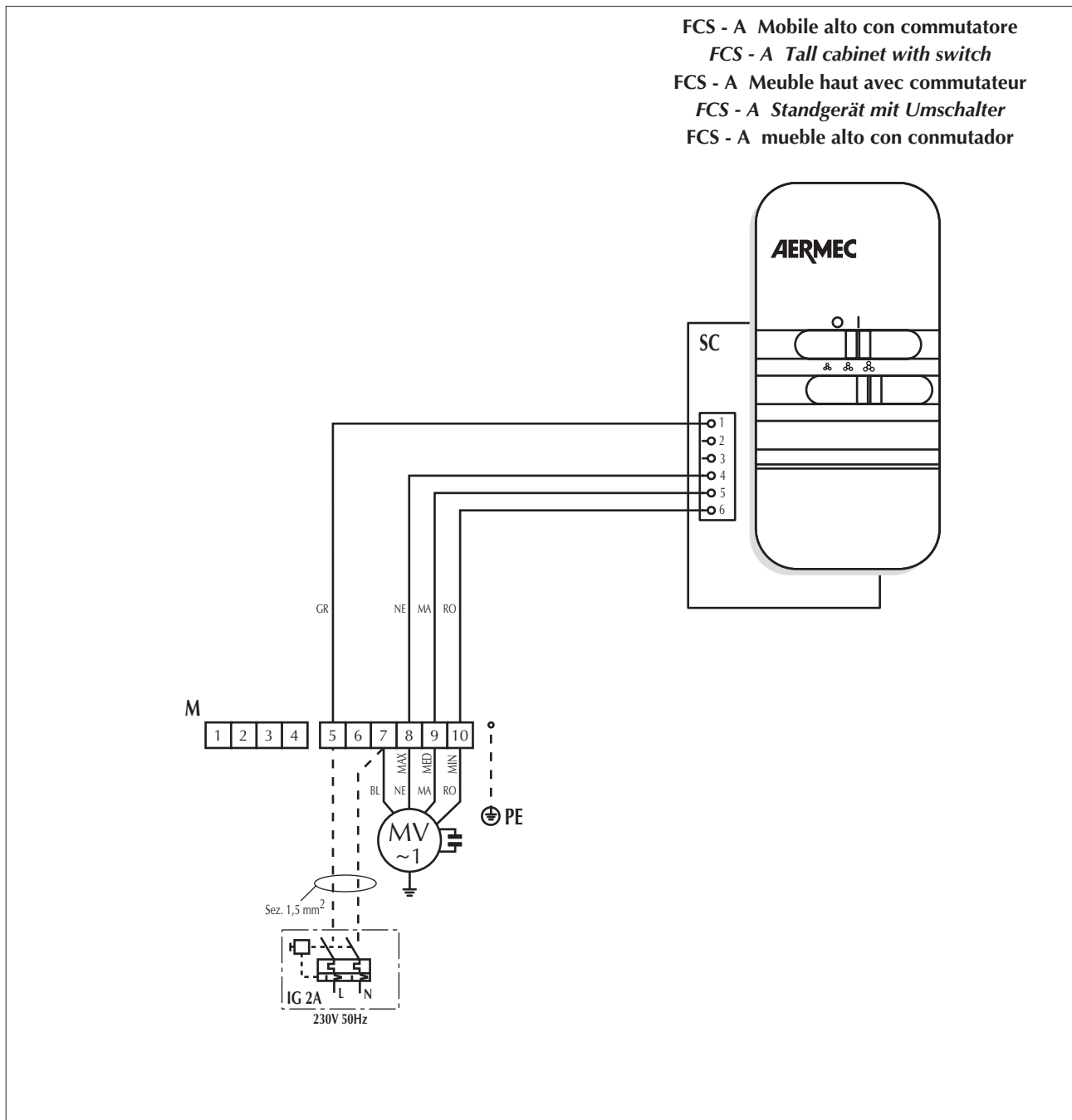

PACKING

The units are shipped in cardboard box standard packing and polystyrene shells.

UNIT INSTALLATION

The fancoil should be installed in such a way as to facilitate routine (filter cleaning) and special maintenance operations, as well as access to the air breather valve on the side of the unit frame (connector side).

To install the unit, proceed as follows:

- a) Extract the air filter.
- b) Remove the housing by loosening the screws (Figures 3).
- c) In the wall-mounted FCS-A units, keep a minimum clearance of 80 mm from the floor. In the case of floor-mounted units on bases, refer to the instructions supplied with the accessory.
- d) Use expansion plugs (not supplied) to secure the unit to the wall, as shown in figures 4.
- e) Make hydraulic connections.
Refer to the dimensional data for the position and diameter of the hydraulic connectors.
Insulate water lines adequately or fit the condensate drainage tray (available as an accessory) to prevent dripping during cooling applications.
The condensate drainage system should be of an adequate size and be positioned to favour runoff (min. 1% slope). If condensate is discharged into the sewage system, install a siphon to prevent return of unpleasant odour into the room.
- f) Make the electrical connections as shown in the wiring diagrams.
- g) Refit the air filter.

ELECTRICAL CONNECTIONS

CAUTION: make sure that electrical power to the machine has been turned off before making electrical connections.

CAUTION: wiring operations and installation of the fancoil and relative accessories should be performed by specialised personnel only.

CONNECTION CABLE SPECIFICATIONS

Use H05V-K or N07V-K type with 300/500 V insulation piped or ducted.

All cables must be piped or ducted until they are not placed inside the fan coil.

The cables coming out of the pipe/duct must not be subjected to stretch or twist. They must be protected from weather conditions.

Stranded wires may only be used in connection with terminating sleeves. It must be ensured that all individual wires are correctly inserted in the sleeve.

For all connections refer to the wiring diagrams supplied with the appliance and specified in this documentation.

To protect fan coils against short circuits, always fit the power cable to the units with 2A 250V (IG) thermo-magnetic all-pole switches with a minimum contact gap of 3 mm.

The assembling place must be chosen so that the max. and min. room temperature limit is respected 0÷45°C (<85% U.R.).

The control panel comprises electrical circuits that are to be connected to a power supply of 230V only.

ROTATING THE COIL

If connection of utilities to the unit requires rotation of the coil, remove the cover or the front pannel, then proceed as follows (Fig. 6):

- remove the screw (1) securing the control panel (2) to the right side of the unit, then remove it after electrical disconnection;
- remove the coil cover sheet (4) by removing the screws;
- remove the screws securing the coil (5), then remove it;
- remove the push-outs (6) on the right side;
- rotate the coil (5), then secure it in the new position with the screws previously removed;
- remount the coil cover sheet (4) and secure it with screws, then insert the plastic plugs (7) supplied in the openings left free by the hydraulic connections; all trays are designed to collect condensate on both sides. In the case of vertical installation, for condensate drainage on the right side, position the drainage union to the right (8).
- to move condensate drainage to the right of the unit, reverse discharge of the tray (3) (if present), then transfer the drainage line (8) to the right;
- slide out the electrical connections from the right side, remove the push-out, then transfer the cable guide (9) from the right to the left side;
- transfer the electrical connections to the left side through the cable guide (9);
- move the terminal block (10) and the ground jumper connection (11) to the left side of the unit;
- refit the control panel on the left side, then make the electrical connections (Fig. 7);
- modify the air filter to the new configuration by changing the position of the external support in relation to the filter frame (Fig. 1); press down on the tab (12 Fig. 2) with a screwdriver while moving the external support (13) until the tab is over the tooth (14).

Release the tab when the position between the support and the filter is as shown in Fig. 1.

Given that the contact block on the unit is off-centre in relation to the cabinet housing, the bases must also be exchanged.

IMPORTANT MAINTENANCE INFORMATION

GB

The fancoil is connected to the power supply and a water circuit. Operations performed by persons without the required technical skills can lead to personal injury to the operator or damage to the unit and surrounding objects.

POWER THE FANCOIL WITH SINGLE-PHASE 230 V ONLY

Use of other power supplies could cause permanent damage to the fancoil.

NEVER USE THE FANCOIL FOR APPLICATIONS FOR WHICH IT WAS NOT DESIGNED

Do not use the fancoil in husbandry applications (e.g. incubation).

AIR THE ROOM

Periodically air the room in which the fancoil has been installed; this is particularly important if the room is occupied by many people, or if gas appliances or sources of odours are present.

CORRECTLY ADJUST THE TEMPERATURE

Room temperature should be regulated to ensure maximum comfort to persons present, particularly in the case of the elderly, infants and invalids. Prevent temperature fluctuations between indoors and outdoors greater than 7 °C during summer.

Note that very low temperatures during summer will lead to greater electricity consumption.

ORIENT AIR FLOW CORRECTLY

Air delivered by the fancoil should not be oriented directly at people; even if air temperature is greater than room temperature, it can cause a cold sensation and consequently discomfort.

DO NOT USE HOT WATER

When cleaning the indoor unit, use rags or soft sponges soaked in warm water (no higher than 40°C).

Do not use chemical products or solvents to clean any part of the fancoil.

Do not splash water on interior or exterior surfaces of the fancoil; danger of short circuit.

PERIODICALLY CLEAN THE FILTER

Frequent cleaning of the filter will ensure more efficient unit operation.

Check whether the filter requires cleaning; if it is particularly dirty, clean it more often.

Clean the filter frequently. Use a vacuum cleaner to remove built up dust.

After cleaning fit it on the fancoil by following the removal procedure in reverse order.

SPECIAL CLEANING

The removable fan volute ensure thorough cleaning of the unit (by specifically trained personnel), essential for installations in venues subject to crowding or in those with special hygiene requirements.

DURING UNIT OPERATION

Always leave the filter on the fancoil during operation (otherwise dust in the air could soil the surface of the coil).

IT IS NORMAL

During cooling, water vapour may be present in the air delivery.

During heating operation a light rustling sound may be perceived near the fancoil.

Sometimes the fancoil can give off unpleasant odours due to the accumulation of substances present in the room: air the room and clean the filter more often.

OPERATING LIMITS

Maximum water inlet temperature 80 °C

Maximum working pressure 8 bar

Minimum average water temperature

To prevent the formation of condensation on the exterior of the unit while the fan is operating, the average water temperature should not drop beneath the limits shown in the table below, determined by the ambient conditions. These limits refer to unit operation with fan at minimum speed. Note that condensation may form on the exterior of the unit if cold water circulates through the coil while the fan is off for prolonged periods of time, so it is advisable to fit the additional three-way valve.

MINIMUM AVERAGE WATER TEMPERATURE	Dry bulb temperature °C					
	21	23	25	27	29	31
	3	3	3	3	3	3
	3	3	3	3	3	3
Wet bulb temperature °C	3	3	3	3	3	3
	6	5	4	3	3	3
	-	8	7	6	5	5

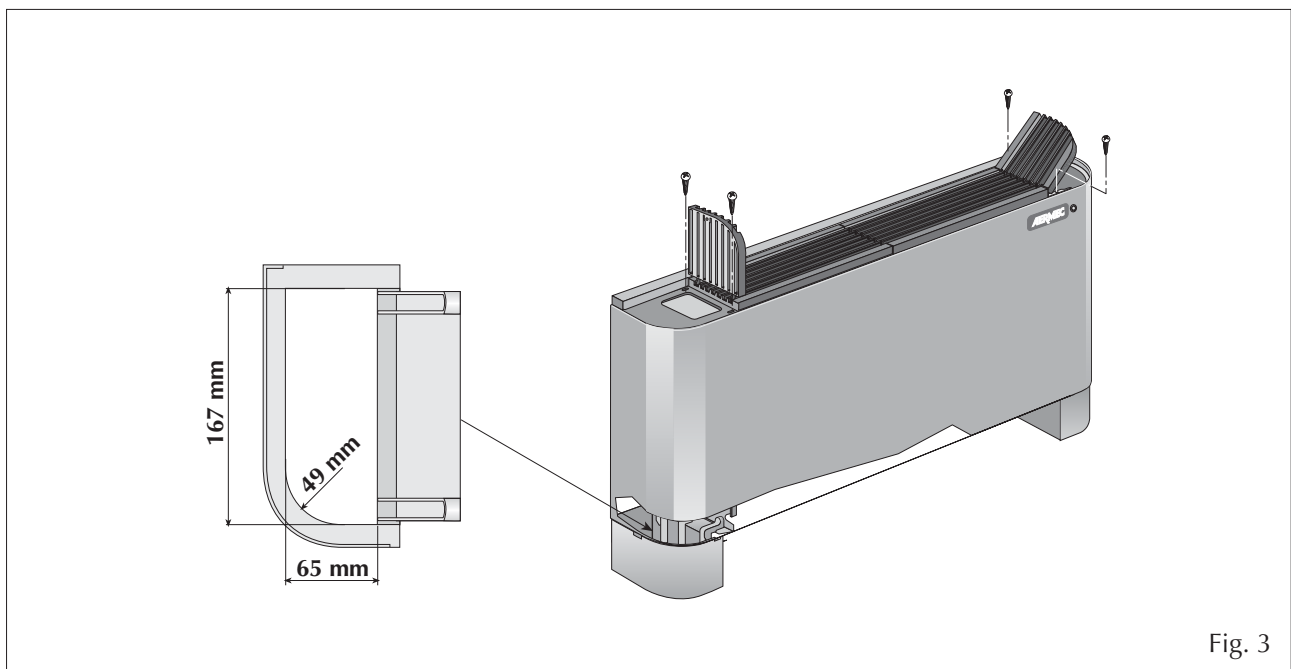
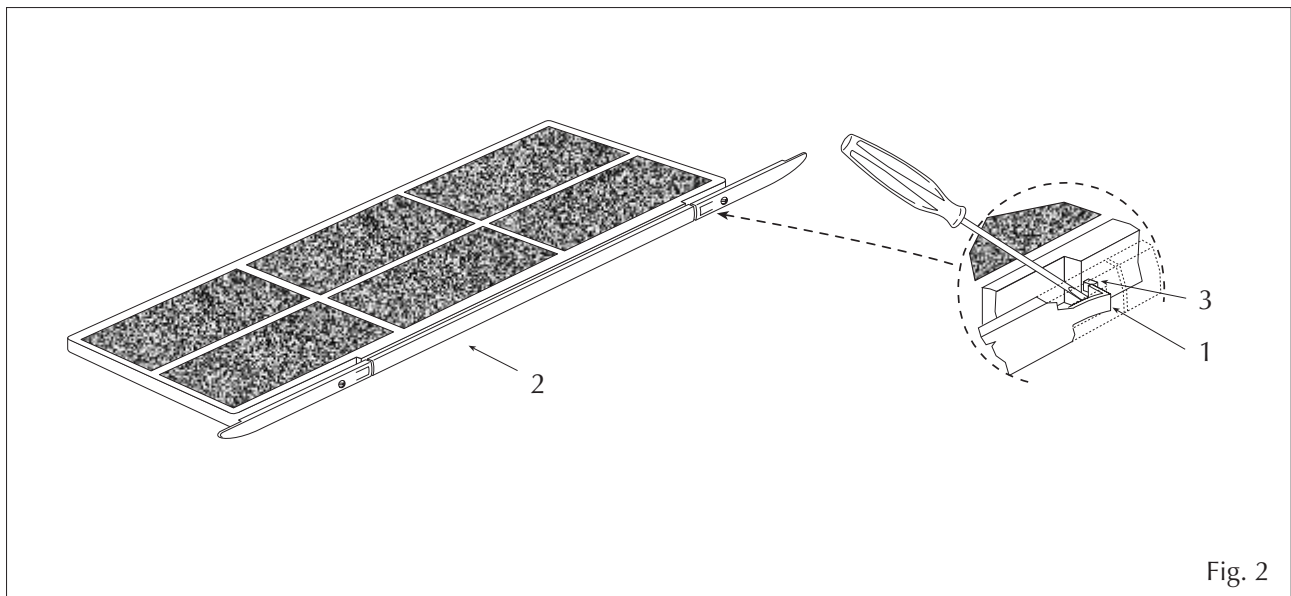
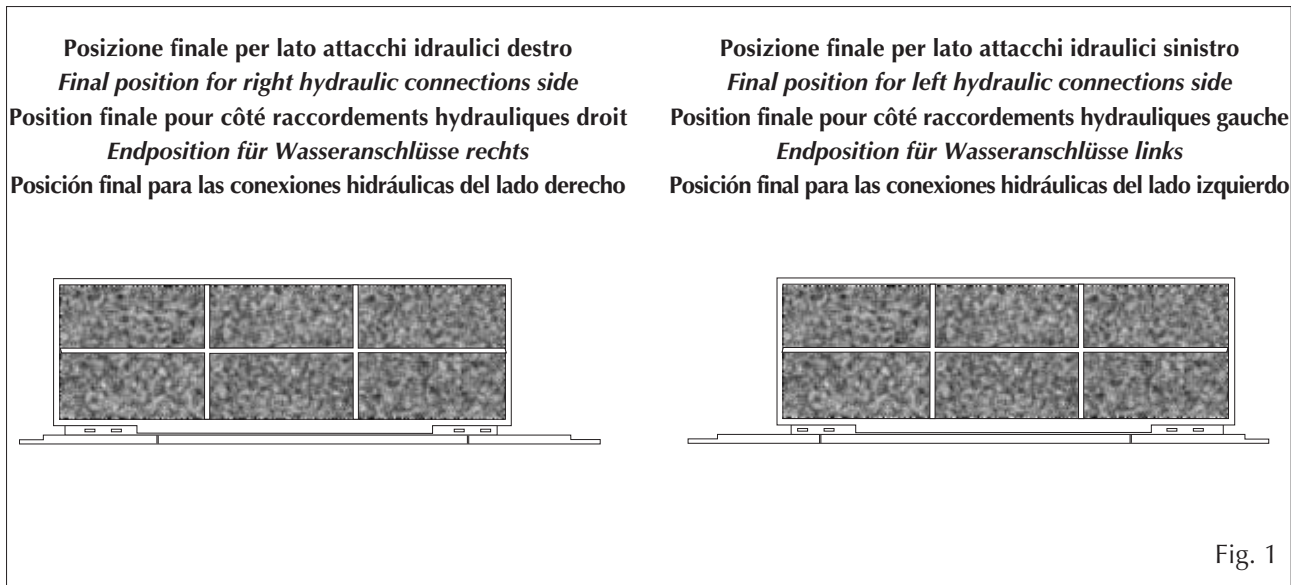

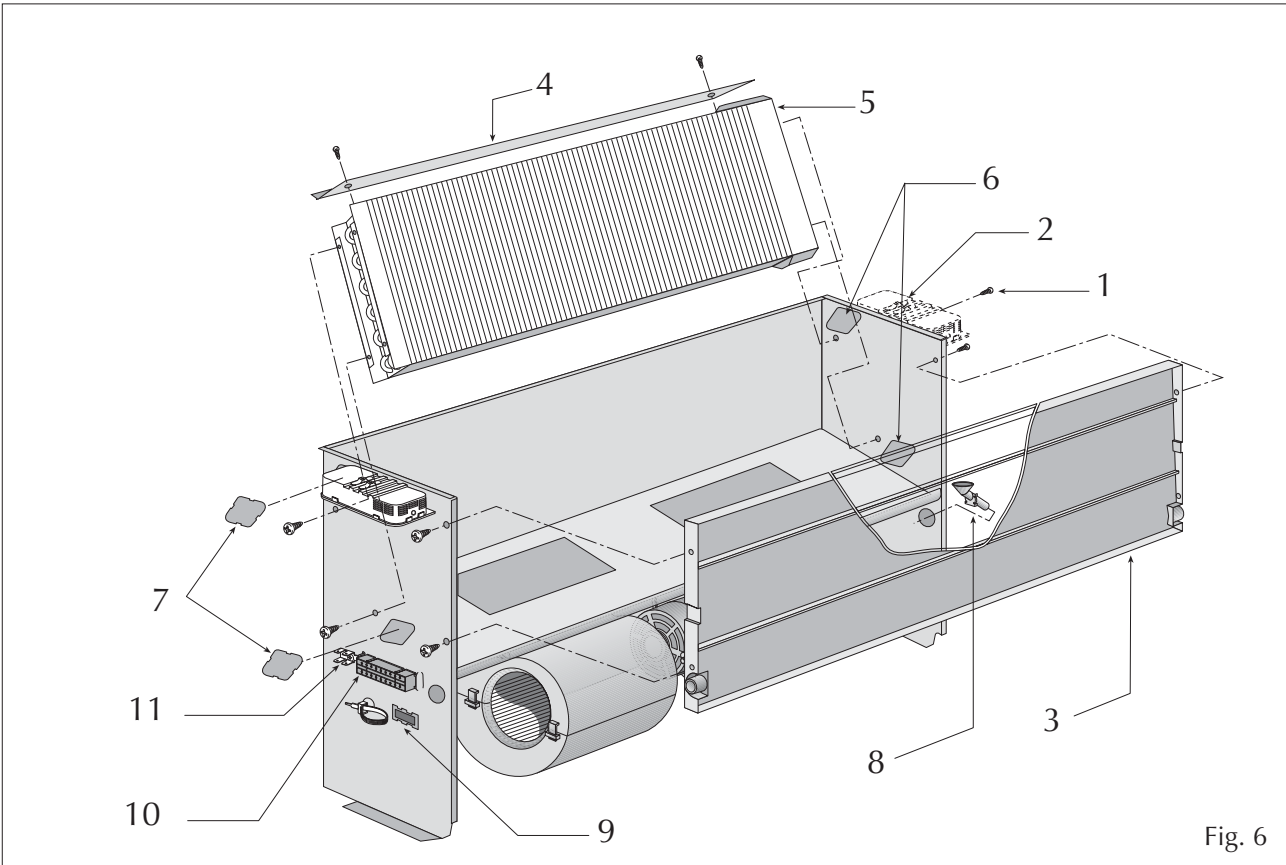
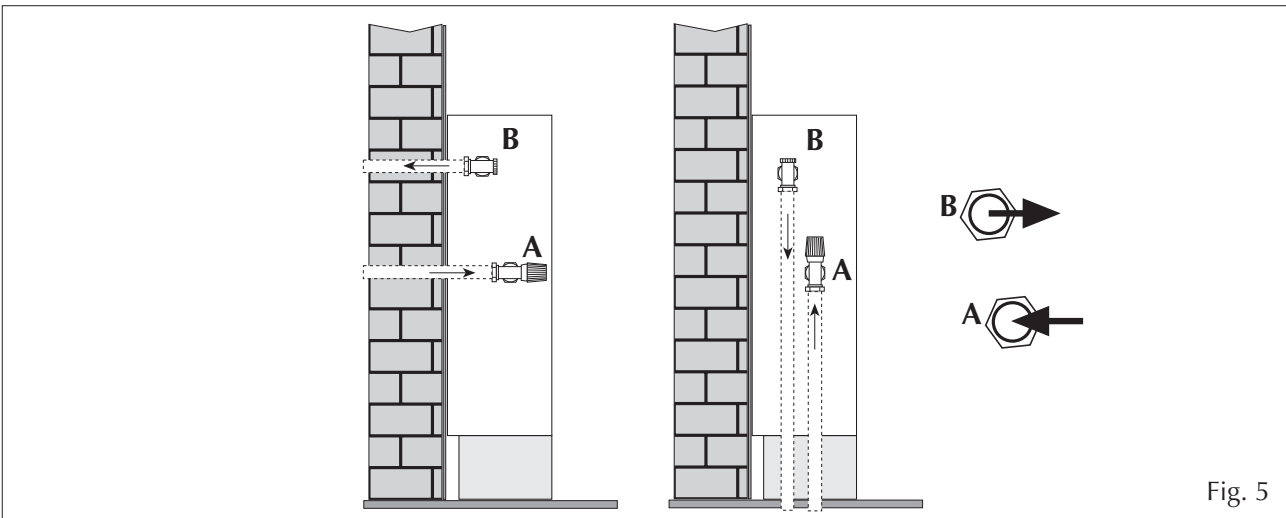
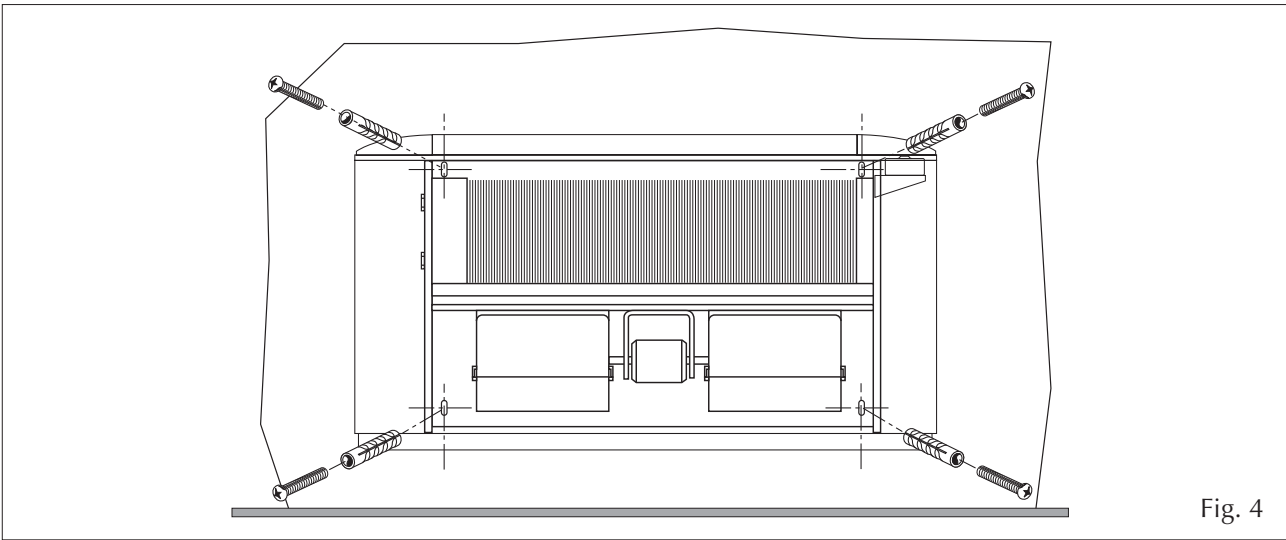

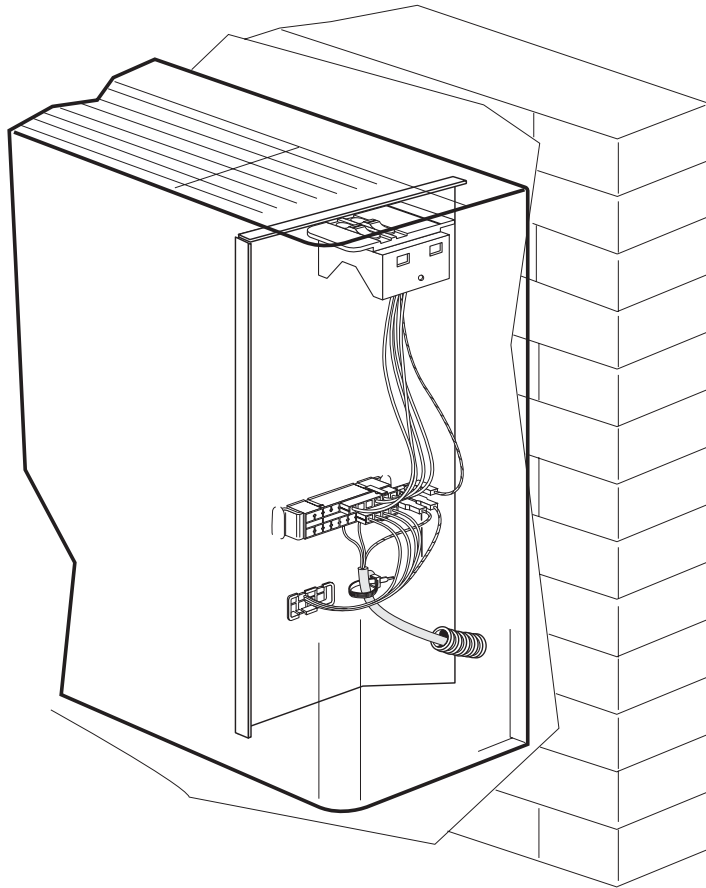

Fig. 7

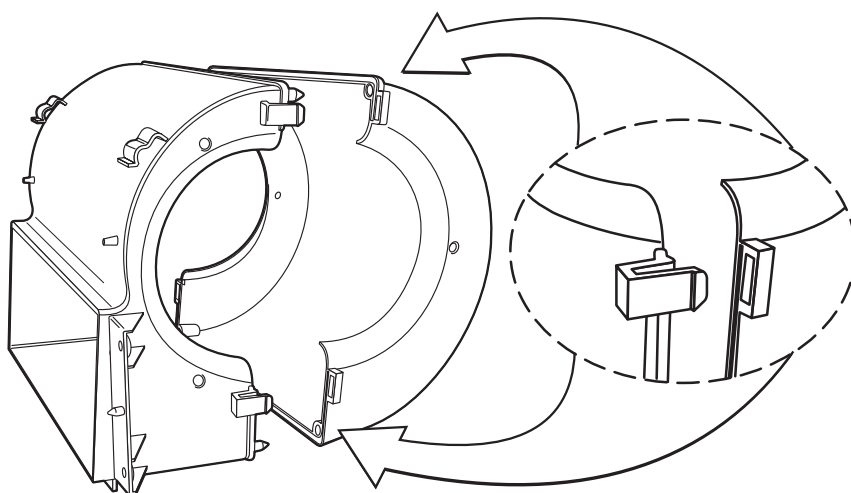

Fig. 8

GARANZIA DI 3 ANNI

La garanzia è valida solo se l'apparecchio è venduto ed installato sul territorio italiano. Il periodo decorre dalla data d'acquisto comprovata da un documento che abbia validità fiscale (fattura o ricevuta) e che riporti la sigla commerciale dell'apparecchio. Il documento dovrà essere esibito, al momento dell'intervento, al tecnico del Servizio Assistenza Aermec di zona.

Il diritto alla garanzia decade in caso di:

- interventi di riparazione effettuati sull'apparecchiatura da tecnici non autorizzati;
- guasti conseguenti ad azioni volontarie o accidentali che non derivino da difetti originari dei materiali di fabbricazione.

AERMEC Spa effettuerà la riparazione o la sostituzione gratuita, a sua scelta, delle parti di apparecchiatura che dovessero presentare difetti dei materiali o di fabbricazione tali da impedirne il normale funzionamento. Gli eventuali interventi di riparazione o sostituzione di parti dell'apparecchio, non modificano la data di decorrenza e la durata del periodo di garanzia. Le parti difettose sostituite resteranno di proprietà della AERMEC Spa.

Non è prevista in alcun caso la sostituzione dell'apparecchio. La garanzia non copre le parti dell'apparecchio che risultassero difettose a causa del mancato rispetto delle istruzioni d'uso, di un'errata installazione o manutenzione, di danneggiamenti dovuti al trasporto, di difetti dell'impianto (es: scarichi di condensa non efficienti). Non sono coperte, infine, le normali operazioni di manutenzione periodica (es: la pulizia dei filtri d'aria) e la sostituzione delle parti di normale consumo (es: i filtri d'aria).

Le agenzie di Vendita Aermec ed i Servizi di Assistenza Tecnica Aermec della vostra provincia sono negli Elenchi telefonici dei capoluoghi di provincia - vedi "Aermec" - e nelle Pagine Gialle alla voce "Condizionatori d'aria - Commercio".



I dati tecnici riportati nella presente documentazione non sono impegnativi. L'Aermec S.p.A. si riserva la facoltà di apportare in qualsiasi momento tutte le modifiche ritenute necessarie per il miglioramento del prodotto.

Technical data shown in this booklet are not binding. Aermec S.p.A. shall have the right to introduce at any time whatever modifications deemed necessary to the improvement of the product.

Les données mentionnées dans ce manuel ne constituent aucun engagement de notre part. Aermec S.p.A. se réserve le droit de modifier à tous moments les données considérées nécessaires à l'amélioration du produit.

Im Sinne des technischen Fortschrittes behält sich Aermec S.p.A. vor, in der Produktion Änderungen und Verbesserungen ohne Ankündigung durchzuführen.

Los datos técnicos de este documento no son vinculantes. Aermec S.p.A. se reserva la facultad de aportar, en cualquier momento, todos los cambios considerados necesarios para la mejora del producto.

AERMEC S.p.A.

I 37040 Bevilacqua (VR) - Italia
Via Roma, 44 - Tel. (+39) 0442 633111
Telefax (+39) 0442 93566 - 0442 93730
www.aermec.com



Servizio 199 aperto sia a Rete Fissa che a Rete Mobile
Costi massimi della chiamata, iva inclusa: da Rete Fissa 0,14 EUR/min.
dai cellulari 0,42 EUR/min e 0,15 EUR di addebito alla risposta.