

MODEL

PUHY-P250YHM-A
PUHY-P500YSHM-A
PQHY-P250YHM-A
PFD-P250VM-E
PFD-P500VM-E

DATA BOOK

Safety Precautions

- Before installing the unit, thoroughly read the following safety precautions.
- Observe these safety precautions for your safety.

WARNING

This symbol is intended to alert the user to the presence of important instructions that must be followed to avoid the risk of serious injury or death.

CAUTION

This symbol is intended to alert the user to the presence of important instructions that must be followed to avoid the risk of serious injury or damage to the unit.

- After reading this manual, give it to the user to retain for future reference.
 - Keep this manual for easy reference. When the unit is moved or repaired, give this manual to those who provide these services.
- When the user changes, make sure that the new user receives this manual.

WARNING

Ask your dealer or a qualified technician to install the unit.

Improper installation by the user may result in water leakage, electric shock, smoke, and/or fire.

Properly install the unit on a surface that can withstand the weight of the unit.

Unit installed on an unstable surface may fall and cause injury.

Only use specified cables. Securely connect each cable so that the terminals do not carry the weight of the cable.

Improperly connected or fixed cables may produce heat and start a fire.

Take appropriate safety measures against strong winds and earthquakes to prevent the unit from falling.

If the unit is not installed properly, the unit may fall and cause serious injury to the person or damage to the unit.

Do not make any modifications or alterations to the unit. Consult your dealer for repair.

Improper repair may result in water leakage, electric shock, smoke, and/or fire.

Do not touch the heat exchanger fins.

The fins are sharp and dangerous.

In the event of a refrigerant leak, thoroughly ventilate the room.

If refrigerant gas leaks and comes in contact with an open flame, poisonous gases will be produced.

Properly install the unit according to the instructions in the installation manual.

Improper installation may result in water leakage, electric shock, smoke, and/or fire.

Have all electrical work performed by an authorized electrician according to the local regulations and instructions in this manual, and a dedicated circuit must be used.

Insufficient capacity of the power supply circuit or improper installation may result in malfunctions of the unit, electric shock, smoke, and/or fire.

The water circuit should be a closed circuit.

 **WARNING**

Securely attach the terminal block cover (panel) to the unit.

If the terminal block cover (panel) is not installed properly, dust and/or water may infiltrate and pose a risk of electric shock, smoke, and/or fire.

Only use the type of refrigerant that is indicated on the unit when installing or reinstalling the unit.

Infiltration of any other type of refrigerant or air into the unit may adversely affect the refrigerant cycle and may cause the pipes to burst or explode.

When installing the unit in a small room, exercise caution and take measures against leaked refrigerant reaching the limiting concentration.

Consult your dealer with any questions regarding limiting concentrations and for precautionary measures before installing the unit. Leaked refrigerant gas exceeding the limiting concentration causes oxygen deficiency.

Consult your dealer or a specialist when moving or reinstalling the unit.

Improper installation may result in water leakage, electric shock, and/or fire.

After completing the service work, check for a gas leak.

If leaked refrigerant is exposed to a heat source, such as a fan heater, stove, or electric grill, poisonous gases may be produced.

Do not try to defeat the safety features of the unit.

Forced operation of the pressure switch or the temperature switch by defeating the safety features of these devices, or the use of accessories other than the ones that are recommended by MITSUBISHI may result in smoke, fire, and/or explosion.

Always use an air cleaner, humidifier, electric heater, and other accessories specified by Mitsubishi Electric.

Ask an authorized technician to install the accessories. Improper installation by the user may result in water leakage, electric shock, or fire.

Precautions for handling units for use with R410A

CAUTION

Do not use the existing refrigerant piping.

- A large amount of chlorine that may be contained in the residual refrigerant and refrigerating machine oil in the existing piping may cause the refrigerating machine oil in the new unit to deteriorate.
- R410A is a high-pressure refrigerant and can cause the existing pipes to burst.

Use refrigerant pipes made of phosphorus deoxidized copper. Keep the inner and outer surfaces of the pipes clean and free of such contaminants as sulfur, oxides, dust, dirt, shaving particles, oil, and water.

These types of contaminants inside the refrigerant pipes may cause the refrigerant oil to deteriorate.

Store the pipes to be installed indoors, and keep both ends of the pipes sealed until immediately before brazing. (Keep elbows and other joints wrapped in plastic.)

Infiltration of dust, dirt, or water into the refrigerant system may cause the refrigerating machine oil to deteriorate or cause the unit to malfunction.

Use a small amount of ester oil, ether oil, or alkylbenzene to coat flares and flanges.

Infiltration of a large amount of mineral oil may cause the refrigerating machine oil to deteriorate.

Charge liquid refrigerant (as opposed to gaseous refrigerant) into the system.

If gaseous refrigerant is charged into the system, the composition of the refrigerant in the cylinder will change and may result in performance loss.

Use a vacuum pump with a reverse-flow check valve.

If a vacuum pump that is not equipped with a reverse-flow check valve is used, the vacuum pump oil may flow into the refrigerant cycle and cause the refrigerating machine oil to deteriorate.

Prepare tools for exclusive use with R410A. Do not use the following tools if they have been used with the conventional refrigerant (gauge manifold, charging hose, gas leak detector, reverse-flow check valve, refrigerant charge base, vacuum gauge, and refrigerant recovery equipment.).

- If the refrigerant or the refrigerating machine oil left on these tools are mixed in with R410A, it may cause the refrigerating machine oil to deteriorate.
- Infiltration of water may cause the refrigerating machine oil to deteriorate.
- Gas leak detectors for conventional refrigerants will not detect an R410A leak because R410A is free of chlorine.

Do not use a charging cylinder.

If a charging cylinder is used, the composition of the refrigerant will change, and the unit may experience power loss.

Exercise special care when handling the tools for use with R410A.

Infiltration of dust, dirt, or water into the refrigerant system may cause the refrigerating machine oil to deteriorate.

Only use refrigerant R410A.

The use of other types of refrigerant that contain chlorine (i.e. R22) may cause the refrigerating machine oil to deteriorate.

Before installing the unit

WARNING

Do not install the unit where a gas leak may occur.

If gaseous refrigerant leaks and piles up around the unit, it may be ignited.

Do not use the unit to keep food items, animals, plants, artifacts, or for other special purposes.

The unit is not designed to preserve food products.

Do not use the unit in an unusual environment.

- Do not install the unit where a large amount of oil or steam is present or where acidic or alkaline solutions or chemical sprays are used frequently. Doing so may lead to a remarkable drop in performance, electric shock, malfunctions, smoke, and/or fire.
- The presence of organic solvents or corrosive gas (i.e. ammonia, sulfur compounds, and acid) may cause gas leakage or water leakage.

When installing the unit in a hospital, take appropriate measures to reduce noise interference.

High-frequency medical equipment may interfere with the normal operation of the air conditioner or vice versa.

Do not install the unit on or over things that cannot get wet.

When the humidity level exceeds 80% or if the drainage system is clogged, the indoor unit may drip water. Drain water is also discharged from the outdoor unit. Install a centralized drainage system if necessary.

Before installing the unit (moving and reinstalling the unit) and performing electrical work

CAUTION

Properly ground the unit.

Do not connect the grounding wire to a gas pipe, water pipe, lightning rod, or grounding wire from a telephone pole. Improper grounding may result in electric shock, smoke, fire, and/or malfunction due to noise interference.

Do not put tension on the power supply wires.

If tension is put on the wires, they may break and result in excessive heat, smoke, and/or fire.

Install an earth leakage breaker to avoid the risk of electric shock.

Failure to install an earth leakage breaker may result in electric shock, smoke, and/or fire.

Use the kind of power supply wires that are specified in the installation manual.

The use of wrong kind of power supply wires may result in current leak, electric shock, and/or fire.

Use breakers and fuses (current breaker, remote switch <switch + Type-B fuse>, moulded case circuit breaker) with the proper current capacity.

The use of wrong capacity fuses, steel wires, or copper wires may result in malfunctions, smoke, and/or fire.

Do not spray water on the air conditioner or immerse the air conditioner in water.

Otherwise, electric shock and/or fire may result.

When handling units, always wear protective gloves to protect your hands from metal parts and high-temperature parts.

Periodically check the installation base for damage.

If the unit is left on a damaged platform, it may fall and cause injury.

Properly install the drain pipes according to the instructions in the installation manual. Keep them insulated to avoid dew condensation.

Improper plumbing work may result in water leakage and damage to the furnishings.

Exercise caution when transporting products.

- Products weighing more than 20 kg should not be carried alone.
- Do not carry the product by the PP bands that are used on some products.
- Do not touch the heat exchanger fins. They are sharp and dangerous.
- When lifting the unit with a crane, secure all four corners to prevent the unit from falling.

Properly dispose of the packing materials.

- Nails and wood pieces in the package may pose a risk of injury.
- Plastic bags may pose a risk of choking hazard to children. Tear plastic bags into pieces before disposing of them.

Before the test run

 **CAUTION**

Turn on the unit at least 12 hours before the test run.

Keep the unit turned on throughout the season. If the unit is turned off in the middle of a season, it may result in malfunctions.

To avoid the risk of electric shock or malfunction of the unit, do not operate switches with wet hands.

Do not touch the refrigerant pipes with bare hands during and immediately after operation.

During or immediately after operation, certain parts of the unit such as pipes and compressor may be either very cold or hot, depending on the state of the refrigerant in the unit at the time. To reduce the risk of frost bites and burns, do not touch these parts with bare hands.

Do not operate the unit without panels and safety guards.

Rotating, high-temperature, or high-voltage parts on the unit pose a risk of burns and/or electric shock.

Do not turn off the power immediately after stopping the operation.

Keep the unit on for at least five minutes before turning off the power to prevent water leakage or malfunction.

Do not operate the unit without the air filter.

Dust particles may build up in the system and cause malfunctions.

Contents

Safety Precautions

I. General Equipment Descriptions

- 1. Unit configuration table1
- 2. Operable temperature range3

II. Product Specifications

- 1. Specifications4
 - (1) Indoor unit
 - (2) Outdoor unit / Heat source unit
- 2. External Dimensions6
 - (1) Indoor unit
 - (2) Outdoor unit / Heat source unit
- 3. Center of Gravity11
 - (1) Indoor unit
 - (2) Outdoor unit / Heat source unit
- 4. Electrical Wiring Diagrams13
 - (1) Indoor unit
 - (2) Outdoor unit / Heat source unit
- 5. Refrigerant Circuit Diagram And Thermal Sensor17
- 6. Optional Parts22
 - (1) Outdoor unit
- 7. Controller23
 - (1) MA remote controller

III. Product Data

- 1. Capacity Curves24
 - (1) Correction by temperature
 - (2) Part Load Performance
 - (3) Correction by refrigerant piping length
 - (4) Correction by indoor unit airflow rate
 - (5) SHF Curves
- 2. Sound Levels28
 - (1) Measurement condition
 - (2) NC Curves
- 3. Fan Characteristics Curves30

IV. System Design

- 1. Piping Design33
 - (1) PFD-P250VM-E
 - (2) PFD-P500VM-E (two refrigerant circuit system)
 - (3) PFD-P500VM-E (single refrigerant circuit system)
 - (4) Refrigerant charging calculation
- 2. Designing of water circuit system37
- 3. Water piping work49
- 4. Control Wiring50
 - (1) Specifications of control wiring and maximum length of wiring

- 5. Types of switch settings and setting methods51
 - (1) Address setting
 - (2) Power supply switch connector connection on the outdoor unit
 - (3) Choosing the temperature detection spot by indoor unit
(Factory Setting: SWC "Standard")
 - (4) Setting the MA "Sub" controller
 - (5) Connection of two refrigerant circuits
- 6. Sample System Connection53
 - (1) System with MA remote controller
 - (2) System with MA remote controller and AG-150A
- 7. External input/output specifications58
 - (1) Input/output specifications
 - (2) Wiring
 - (3) Wiring Method
 - (4) Switch setting
 - (5) Dehumidification priority control
 - (6) Normal/Local switching switch (SW9)
- 8. System Rotation Control63
- 9. Notes on the use of optional accessories63
- 10. Caution for refrigerant leakage64
 - (1) Refrigerant property
 - (2) Confirm the Critical concentration and take countermeasure

V. Air Conditioning the Computer Room

- 1. Main Features of the Floor-Duct Air Conditioners65
- 2. Features of air-conditioner for computer room65
- 3. Step-by-Step Plan for the Implementation of the Air-Conditioning66
- 4. Conditions for the Installation of Computer-Room Air Conditioners67
 - (1) Outdoor Temperature and Humidity
 - (2) Indoor Temperature and Humidity
 - (3) Matching the Volume of Air Flow
 - (4) Considering a Back-up Air Conditioning System
- 5. Setting the Air conditioners68
 - (1) Air-Conditioning Load
 - (2) Sample Selection of Air Conditioners
- 6. Automatic Control of the Computer Room70

VI. Maintenance / Inspection

- 1. Maintenance/Inspection Schedule71
 - (1) Approximate Longevity of Various Parts
 - (2) Notes
 - (3) Details of Maintenance/Inspection

I. General Equipment Descriptions

1. Unit configuration table

		10HP system	20HP system
Model Name	Indoor unit	PFD-P250VM-E	PFD-P500VM-E
	Outdoor unit	PUHY-P250YHM-A	PUHY-P250YHM-A × 2 PUHY-P500YSHM-A
	Heat source unit	PQHY-P250YHM-A	PQHY-P250YHM-A × 2

*PFD-type indoor units cannot be connected to outdoor units other than the ones specified above.

*PFD-type indoor units and other types of indoor units cannot coexist in the same refrigerant system.

*It is necessary to change pulley and V-belt when using it by the power supply frequency 60Hz.

*For restrictions when the PFD-type indoor units are connected (related to the system), see IV.system Design.

*20HP system of the heat source unit cannot be connected to a single refrigerant circuit.

<10HP System>

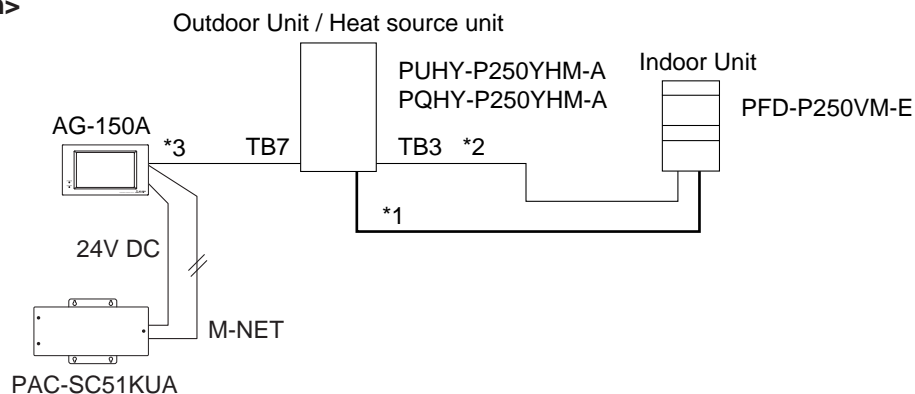

When using a PFD-P250VM-E as an indoor unit, connect an outdoor unit PUHY-P250YHM-A / PQHY-P250YHM-A to each indoor unit and operate with a built-in remote control for the indoor unit.

*1: Bold line indicates refrigerant piping (gas/liquid). This system consists of single refrigerant circuit.

*2: Indicates TB3-type transmission line that connects the indoor and outdoor units.

This system consists of single refrigerant circuit.

*3: Indicates TB7-Type transmission line that allows the unit to communicate with the controller.

<20HP System>

■ Single refrigerant circuit

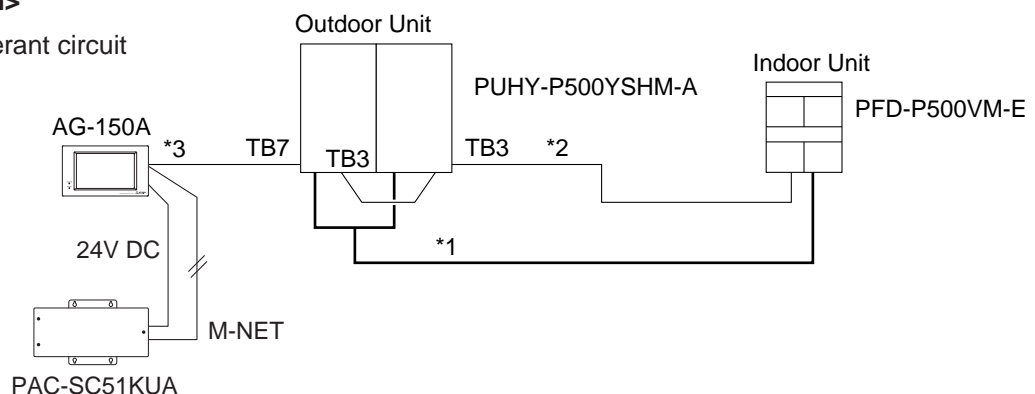

When using a PFD-P500VM-E as an indoor unit, connect 1 PUHY-P500YSHM-A outdoor unit to each indoor unit and operate with a built-in remote control for the indoor unit.

*1: Bold line indicates refrigerant piping (gas/liquid). This system consists of single refrigerant circuit.

*2: Indicates TB3-type transmission line that connects the indoor and outdoor units.

This system consists of single refrigerant circuit.

*3: Indicates TB7-type transmission line that allows the unit to communicate with the controller.

■ Two refrigerant circuits

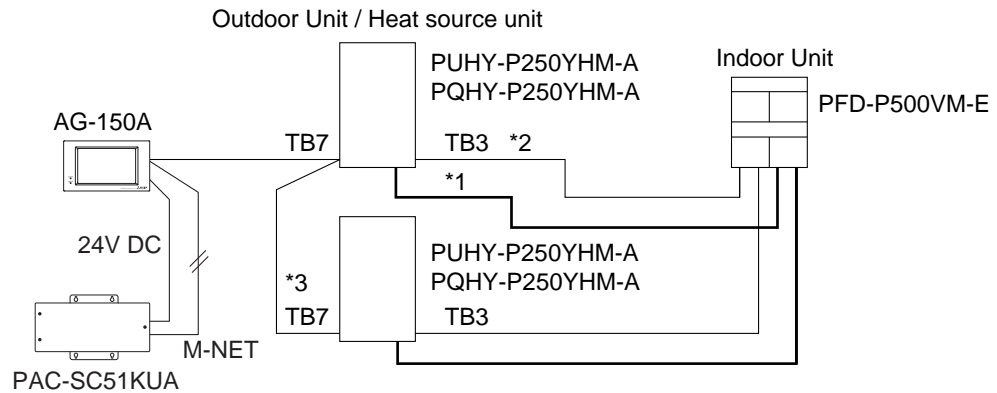

When using a PFD-P500VM-E as an indoor unit, connect 2 PUHY-P250YHM-A / PQHY-P250YHM-A outdoor units to each indoor unit and operate with a built-in remote control for the indoor unit. At factory shipment, this model of indoor unit is designed and set to accommodate a single refrigerant circuit.

Connection of two refrigerant circuits to the indoor unit requires setting change and pipe work.

*1: Bold line indicates refrigerant piping (gas/liquid). This system consists of two refrigerant circuits.

*2: Indicates TB3-type transmission line that connects the indoor and outdoor units.

This system consists of two refrigerant circuit.

*3: Indicates TB7-type transmission line that allows the unit to communicate with the controller.

2. Operable temperature range

■ PFD unit + PUHY-P250YHM-A, PUHY-P500YSHM-A

- Cooling

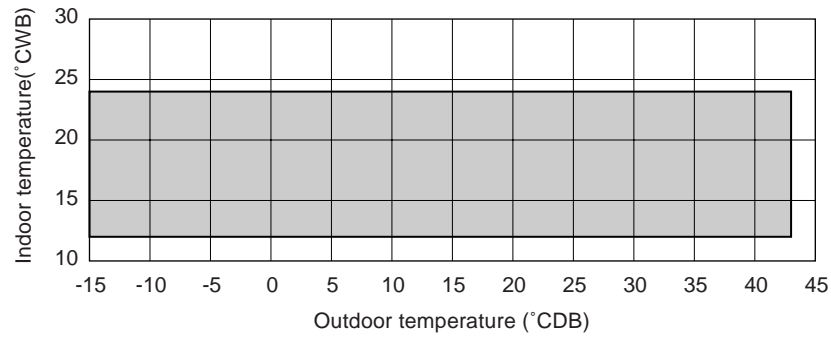

* The height between the Outdoor PUHY-P-YHM-A and Indoor could make the operation temperature range narrow. For details, refer to p.33, IV-1. Piping Design.

- Heating

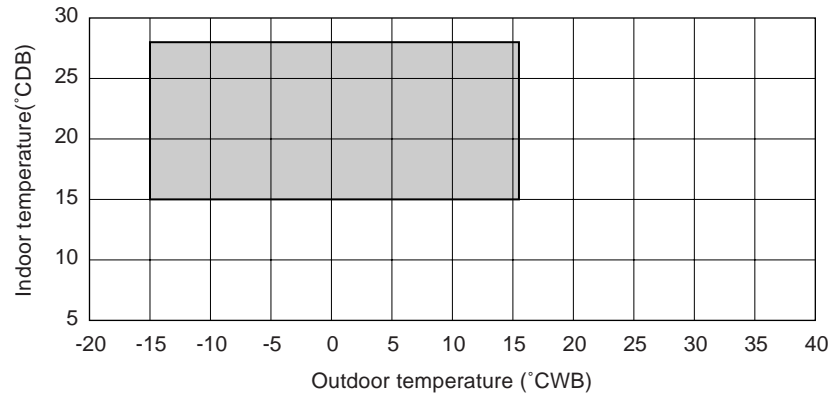

■ PFD unit + PQHY-P250YHM-A

- Cooling

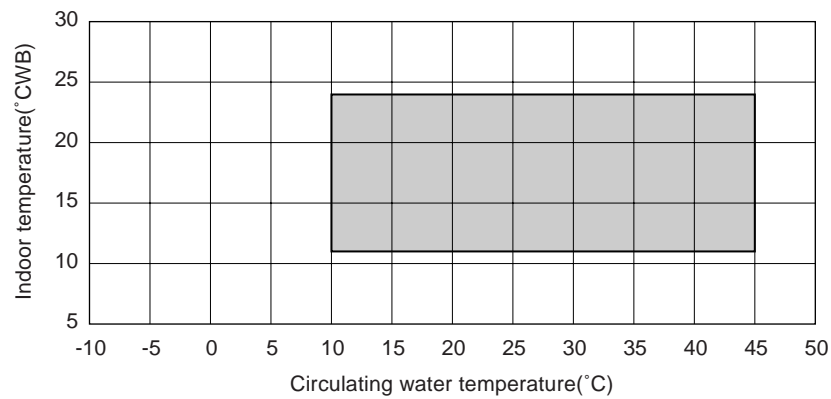

- Heating

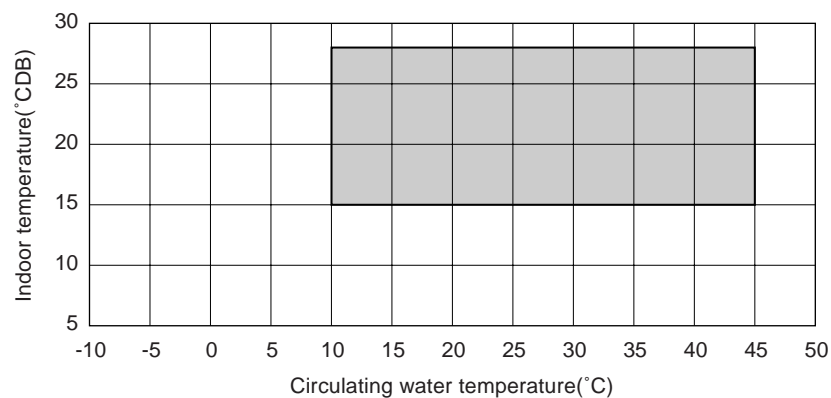

II. Product Specifications

1. Specifications

(1) Indoor Unit

Model name		PFD-P250VM-E		PFD-P500VM-E		
		Cooling	Heating * 1	Cooling	Heating * 1	
System capacity	kW	28.0	31.5	56.0	63.0	
Power source		3N~380/400/415V(50Hz), 400/415V(60Hz)				
Power input	kW	2.5		5.0		
Current	A	5.3/5.0/4.9		9.5/9.0/8.7		
Fan	Type x Quantity	Sirocco fan x 1		Sirocco fan x 2		
	Airflow rate	m ³ /min	160		320	
	External static pressure	Pa	120		120	
	Motor Output	kW	2.2		4.4	
Refrigerant		R410A				
External finish		Galvanized steel plate (with polyester coating) <MUNSEL 2.9GY 8.6/0.3(White) 7.2GB 3.2/5.3(Blue) or similar>				
External dimensions HxWxD	mm	1,950 x 1,380 x 780		1,950 x 1,980 x 780		
Protection devices (Fan)		Thermal switch				
Refrigerant piping diameter * 2	Single refrigerant circuit	Liquid pipe	ø 9.52 Brazed (ø 12.7 for over 90m)		Liquid pipe	ø 15.88 Brazed
		Gas pipe	ø 22.2 Brazed		Gas pipe	ø 28.58 Brazed
	Two refrigerant circuit		-		Liquid pipe	ø 9.52 Brazed (ø 12.7 for over 90m)
						Gas pipe
Refrigerant piping allowable length	m	165		165		
Sound pressure level	dB(A)	59		63		
Heat exchanger		Cross fin (Aluminum plate fin and copper tube)				
Air filter		PP Honeycomb fabric (washable)				
Net weight	kg	380		520		

Note: *1. Heating can be used only by the indoor warming-up.

*2. At factory shipment, this model of indoor unit is designed and set to accommodate a single refrigerant circuit. Connection of two refrigerant circuits to the indoor unit requires setting change and pipe work.

** Installation/foundation work, electric connection work, duct work, insulation work, power source switch and other items are not specified in the specifications.

(2) Outdoor Unit / Heat source unit

Model name		PUHY-P250YHM-A (-BS) connected with PFD series			
		Cooling		Heating	
Capacity	*1	kW	28.0	31.5	
Power source			3N ~ 380/400/415V 50/60Hz		
Power input		kW	6.8		6.6
Current		A	11.4/10.9/10.5		11.1/10.5/10.2
Fan	Type x Quantity		Propeller fan x 1		
	Airflow rate	m ³ /min	185		
	Motor output	kW	0.46 x 1		
Compressor	Type		Inverter scroll hermetic compressor		
	Motor output	kW	6.7		
	Crankcase heater	kW	0.035		
Heat exchanger		Salt-resistant cross fin & copper tube			
Refrigerant / Lubricant		R410A/MEL32			
External finish		Pre-coated galvanized steel sheets (+ powder coating for -BS type) <MUNSEL 5Y 8/1 or similar>			
External dimension HxWxD		mm	1,710 (without legs 1,650) x 920 x 760		
Protection devices	High pressure protection		High pres. Sensor & High pres. Switch at 4.15MPa		
	Compressor		Over-heat protection		
	Fan		Thermal switch		
	Inverter circuit (COMP./FAN)		Over-heat protection, Over-current protection		
Refrigerant piping diameter	High press. pipe		ø9.52 Brazed (ø12.7 for over 90m)		
	Low press. pipe		ø22.2 Brazed		
Sound pressure level	*2	dB(A)	57		
Net weight		kg	200		

Note: *1. Cooling/Heating capacity indicates the maximum value at operation under the following condition.

<Cooling> Indoor : 27°CDB / 19°CWB Outdoor : 35°CDB
<Heating> Indoor : 20°CDB Outdoor : 7°CDB / 6°CWB
Pipe length : 7.5m Height difference : 0m

*2. It is measured in anechoic room.

** Installation/foundation work, electrical connection work, duct work, insulation work, power source switch, and other items shall be referred to the Installation Manual.

Model name			PUHY-P500YSHM-A (-BS) connected with PFD series		
			Cooling	Heating	
Capacity	*1	kW	56.0	63.0	
Power source			3N ~ 380/400/415V 50/60Hz		
Power input		kW	13.6	13.2	
Current		A	22.8/21.8/21.0	22.2/21.0/20.4	
Set Model			PUHY-P250YHM-A(-BS)	PUHY-P250YHM-A(-BS)	
Fan	Type x Quantity		Propeller fan x 1		Propeller fan x 1
	Airflow rate	m³/min	185	185	
	Motor output	kW	0.46 x 1	0.46 x 1	
Compressor	Type		Inverter scroll hermetic compressor		Inverter scroll hermetic compressor
	Motor output	kW	6.7	6.7	
	Crankcase heater	kW	0.035	0.035	
Heat exchanger			Salt-resistant cross fin & copper tube		Salt-resistant cross fin & copper tube
Refrigerant / Lubricant			R410A/MEL32		R410A/MEL32
External finish			Pre-coated galvanized steel sheets (+ powder coating for -BS type) <MUNSEL 5Y 8/1 or similar>		
External dimension H x W x D		mm	1,710 (without legs 1,650) x 920 x 760	1,710 (without legs 1,650) x 920 x 760	
Protection devices	High pressure protection		High pres. Sensor & High pres. Switch at 4.15MPa		
	Compressor		Over-heat protection		
	Fan		Thermal switch		
	Inverter circuit (COMP./FAN)		Over-heat protection, Over-current protection		
Refrigerant piping diameter	High press. pipe		ø9.52 Brazed	ø9.52 Brazed	
	Low press. pipe		ø22.2 Brazed	ø22.2 Brazed	
Sound pressure level	*2	dB(A)	60		
Net weight		kg	200	200	

Note: *1. Cooling/Heating capacity indicates the maximum value at operation under the following condition.

<Cooling> Indoor : 27°CDB / 19°CWB Outdoor : 35°CDB
 <Heating> Indoor : 20°CDB Outdoor : 7°CDB / 6°CWB
 Pipe length : 7.5m Height difference : 0m

*2. It is measured in anechoic room.

** Installation/foundation work, electrical connection work, duct work, insulation work, power source switch, and other items shall be referred to the Installation Manual.

Model name			PQHY-P250YHM-A connected with PFD series		
			Cooling	Heating	
Capacity	*1	kW	28.0	31.5	
Power source			3N ~ 380/400/415V 50/60Hz		
Power input		kW	5.45	5.51	
Current		A	9.2/8.7/8.4	9.3/8.8/8.5	
Compressor	Type		Inverter scroll hermetic compressor		
	Motor output	kW	6.3		
	Crankcase heater	kW	0.035 (240V)		
Heat exchanger			Plate type		
Refrigerant / Lubricant			R410A/MEL32		
External finish			Acrylic painted steel plate		
External dimension H x W x D		mm	1,160 (1,100 without legs) x 880 x 550		
Protection devices	High pressure protection		High pres. Sensor & High pres. Switch at 4.15MPa		
	Compressor		Over-heat protection		
	Inverter circuit (COMP./FAN)		Over-heat protection, Over-current protection		
Refrigerant piping diameter	High press. pipe		ø9.52 Brazed (ø12.7 for over 90m)		
	Low press. pipe		ø22.2 Brazed		
Sound pressure level	*2	dB(A)	49		
Net weight		kg	195		

Note: *1. Cooling/Heating capacity indicates the maximum value at operation under the following condition.

<Cooling> Indoor : 27°CDB / 19°CWB Water temperature : 30°C
 <Heating> Indoor : 20°CDB Water temperature : 20°C
 Pipe length : 7.5m Height difference : 0m

*2. It is measured in anechoic room.

** Installation/foundation work, electrical connection work, duct work, insulation work, power source switch, and other items shall be referred to the Installation Manual.

(2) Outdoor unit / Heat source unit

PUHY-P250YHM-A(-BS)

Unit : mm

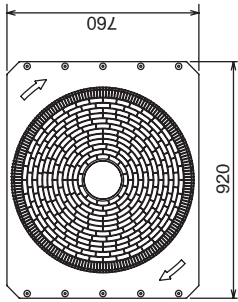

Top view

- <Accessories>
 ● Connecting pipe
 <Gas> · Elbow (ID25.4XOD25.4)...P250 1pc.
 · Pipe (ID25.4XOD22.2)...P250 1pc.
 <Liquid> · Pipe (ID9.52XOD9.52)...P250 1pc.

Note1. Please refer to the next page for information regarding necessary spacing around the unit and foundation work.
 2. The detachable leg can be removed at site.
 3. At brazing of pipes wrap the refrigerant service valve with wet cloth and keep the temperature of refrigerant service valve under 120 C.

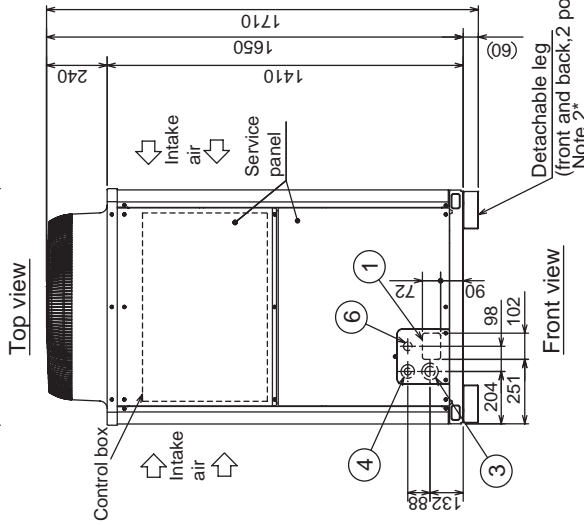

Front view

Detachable leg (front and back, 2 points)
 Note 2*

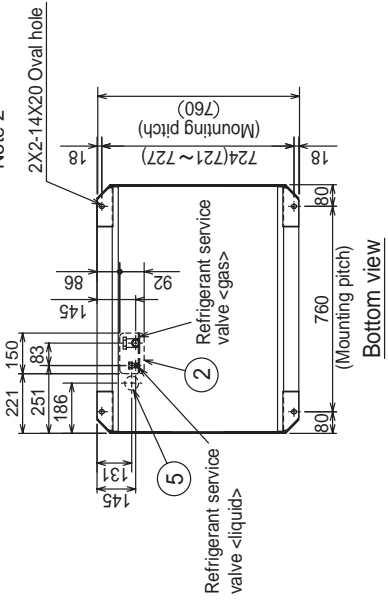

Bottom view

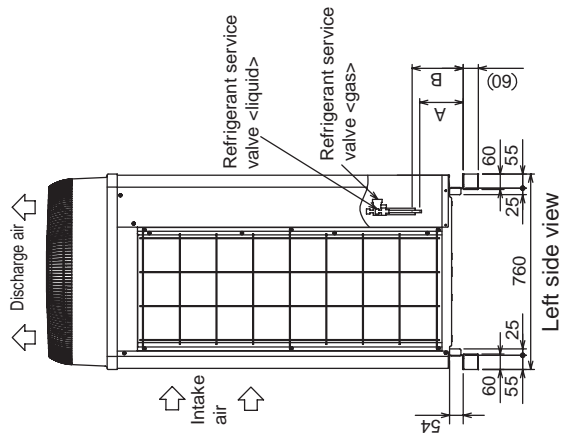

Left side view

NO.	Usage	Specifications
①	Front through hole	102X72 Knockout hole
②	Bottom through hole	150X92 Knockout hole
③	Front through hole	ø65 or ø40 Knockout hole
④	Front through hole	ø52 or ø27 Knockout hole
⑤	Bottom through hole	ø52 Knockout hole
⑥	Front through hole	ø34 Knockout hole

Model	Position dimensions for the refrigerant service valve			Connection specifications for the refrigerant service valve *1	
	Liquid	Gas	B	Liquid	Gas
PUHY-P250YHM	142	172	172	ø9.52 Brazed	ø22.2 Brazed

*1 Connect by using the connecting pipes (for bottom piping and front piping) that are supplied.

PUHY-P500YSHM-A(-BS)

Unit : mm

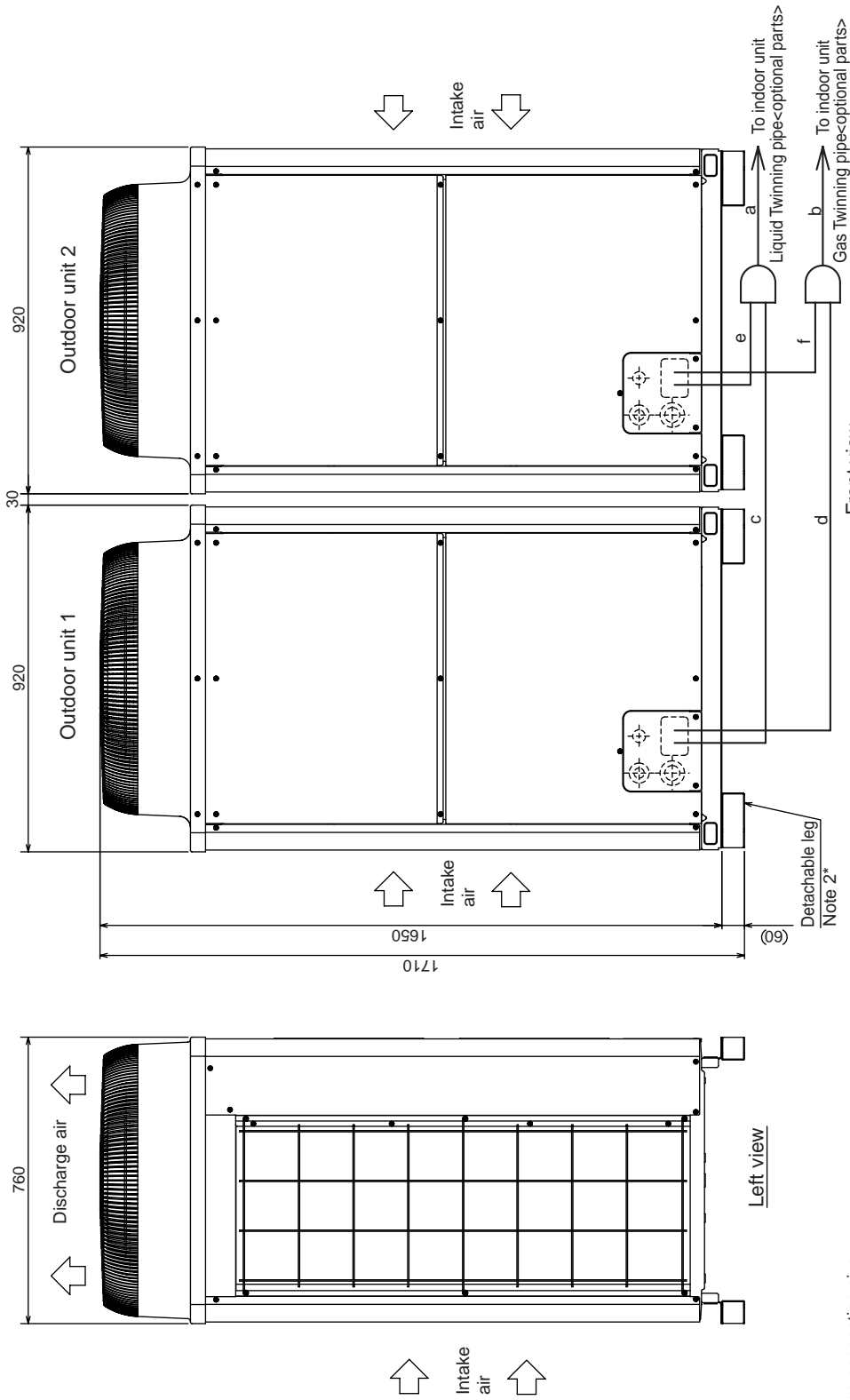

Twinning pipe connection size

Package unit name	PUHY-P500YSHM-A(-BS)
Component unit name	Outdoor unit 1 Outdoor unit 2
Outdoor Twinning Kit(optional parts)	CMY-Y100VBK2
Indoor unit~Twinning pipe	Liquid a Gas b
	ø15.88 ø28.58

Unit model	P250	Gas	d or f
Twinning pipe ~ Outdoor unit	ø9.52	ø22.2	

- Note 1. Connect the pipes as shown in the figure above. Refer to the table above for the pipe size.
- Note 2. The detachable leg can be removed at site.
- Note 3. Twinning pipes should not be tilted more than 15 degrees from the ground. See the Installation Manual for details.

3. Center of Gravity

(1) Indoor unit

● PFD-P250VM-E

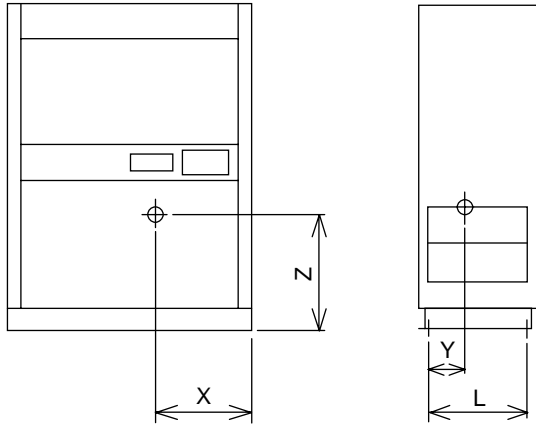

Unit : mm

Model	L	X	Y	Z
PFD-P250VM-E	580	581	222	739

● PFD-P500VM-E

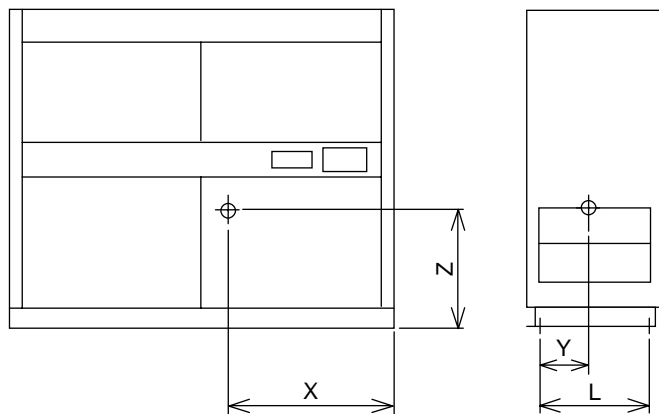

Unit : mm

Model	L	X	Y	Z
PFD-P500VM-E	580	967	270	714

(2) Outdoor unit / Heat source unit

● PUHY-P250YHM-A (-BS)

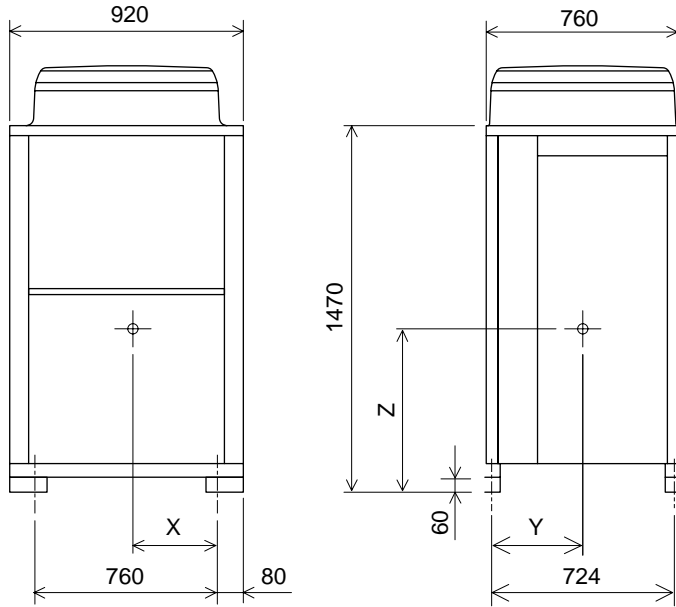

Unit : mm

Model	X	Y	Z
PUHY-P250YHM-A (-BS)	334	329	652

● PQHY-P250YHM-A(-BS)

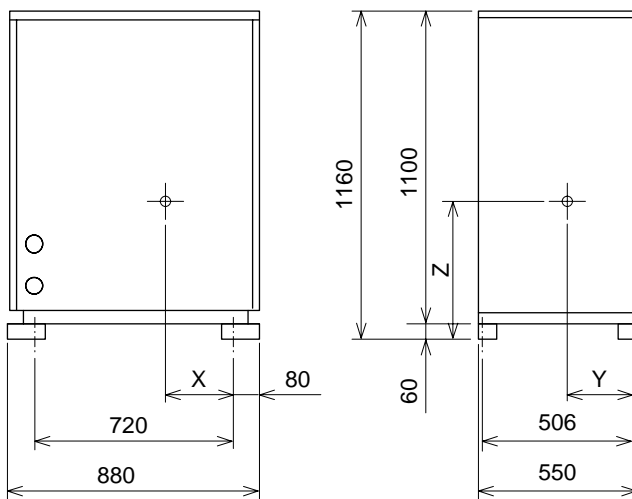

Unit : mm

Model	X	Y	Z
PQHY-P250YHM-A (-BS)	418	250	532

4. Electrical Wiring Diagrams

(1) Indoor unit ● PFD-P250VM-E

SYMBOL	NAME
MF	Fan motor
IB	Indoor controller board
S.B.	Surge absorber board
IFB	External input/output board
TB2	Power source terminal bed
TB5	Transmission terminal bed
TB15	Transmission terminal bed
TB21	Terminal bed for distant location on/off
TB22	<No voltage or current>
TB23	Terminal bed for distant location display
F901	Terminal bed for distant location on/off
F1	<With voltage and current>
ZNR1, ZNR2, ZNR301	Fuse<5A>
DSA1	Varistor
T	Surge absorber
LEV	Transformer
52F	Electronic linear expans.valve
51F	Contactor(fan I/D)
33P1	Over current relay (fan I/D)
TH21	Float switch
TH22	Thermistor (inlet temp.detection)
TH23	Thermistor (piping temp.detection/liquid)
TH24	Thermistor (piping temp.detection/gas)
SW1(L.B.)	Thermistor (outlet temp.detection)
SW2(L.B.)	Switch (for mode selection)
SW3(L.B.)	Switch (for capacity code)
SW4(L.B.)	Switch (for mode selection)
SW9	Switch (normal/local)
SW11(L.B.)	Switch (1st digit address set)
SW12(L.B.)	Switch (2nd digit address set)
SW14(L.B.)	Switch (connection No.set)
SWC(L.B.)	Switch (outlet/inlet temp.control)
X11	Auxiliary relay(check)
Z1	Auxiliary relay(fan)
Z3	Auxiliary relay(fan failure detection)
L1	LED display (fan failure)
L2	LED display (status)
L3	LED display (check)
L4	LED display (power supply)
RC	IMA Remote controller

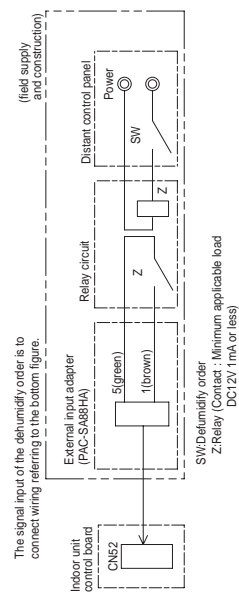
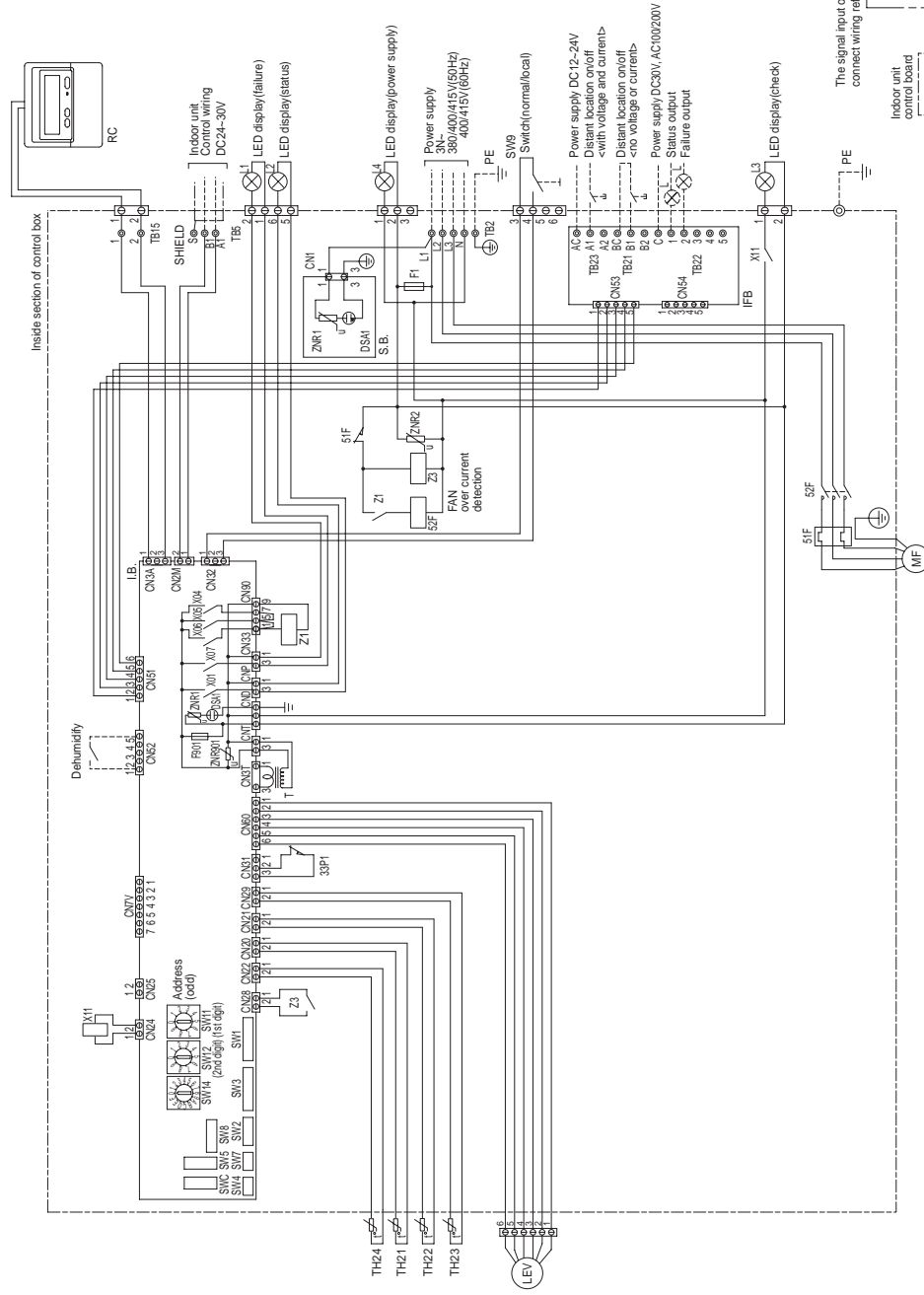

- Note:
- The dotted lines show field wiring.
 - The address setting of the indoor unit should always be odd.
 - The outdoor unit to which the indoor unit is connected with the transmission line, the address of the outdoor unit should be the indoor unit +50.
 - Mark ⊕ indicates terminal bed, ⊕ connector, ⊕ board insertion connector or fastening connector of control board.

● PFD-P500VM-E

SYMBOL	NAME
MF	Fan motor
IB.1, IB.2	Indoor controller board
AD.B.	Adapter board
S.B.	Surge absorber board
IFB	External input/output board
TB2	Power source terminal bed
TB5-1, -2	Transmission terminal bed
TB15	Terminal bed for distant location on/off
TB21	Terminal bed for distant location display
TB22	Terminal bed for distant location display
TB23	Terminal bed for distant location display
F901	Fuse <6.3/6A>
F1	Fuse <5A>
ZNR1, ZNR2, ZNR901	Varistor
DSAT	Surge absorber
T	Transformer
LEV1, 2	Electronic linear expan valve
52F	Contact(fan I/D)
51F	Over current relay (fan I/D)
33P1, 33P2	Floating switch
TH21-1, TH21-2	Thermistor (inlet temp. detection)
TH22-1, TH22-2	Thermistor (piping temp. detection/liquid)
TH23-1, TH23-2	Thermistor (piping temp. detection/gas)
TH24-1, TH24-2	Thermistor (outlet temp. detection)
SW1(L.B.)	Switch (for mode selection)
SW2(L.B.)	Switch (for capacity code)
SW3(L.B.)	Switch (for mode selection)
SW4(L.B.)	Switch (for model selection)
SW9	Switch (normal/local)
SW11(L.B.)	Switch (1st digit address set)
SW12(L.B.)	Switch (2nd digit address set)
SW14(L.B.)	Switch (connection No.set)
SW1C(L.B.)	Switch (outlet/inlet temp. control)
X11, X12	Auxiliary relay (check)
Z1, Z2	Auxiliary relay (fan)
L1	Auxiliary relay (fan failure detection)
L2	LED display (No.1 failure)
L3	LED display (No.2 failure)
L4	LED display (status)
L5	LED display (check)
RC	MA Remote controller

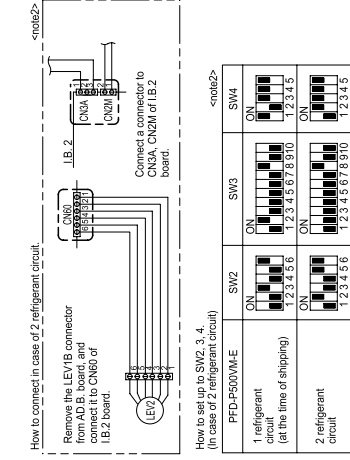
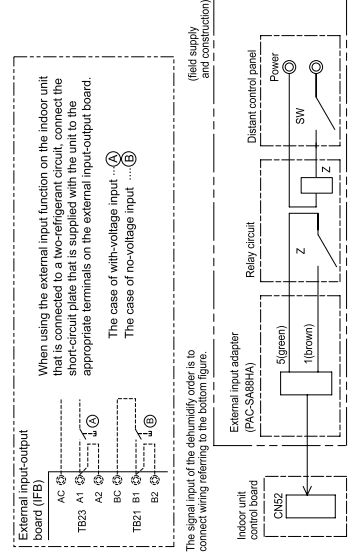
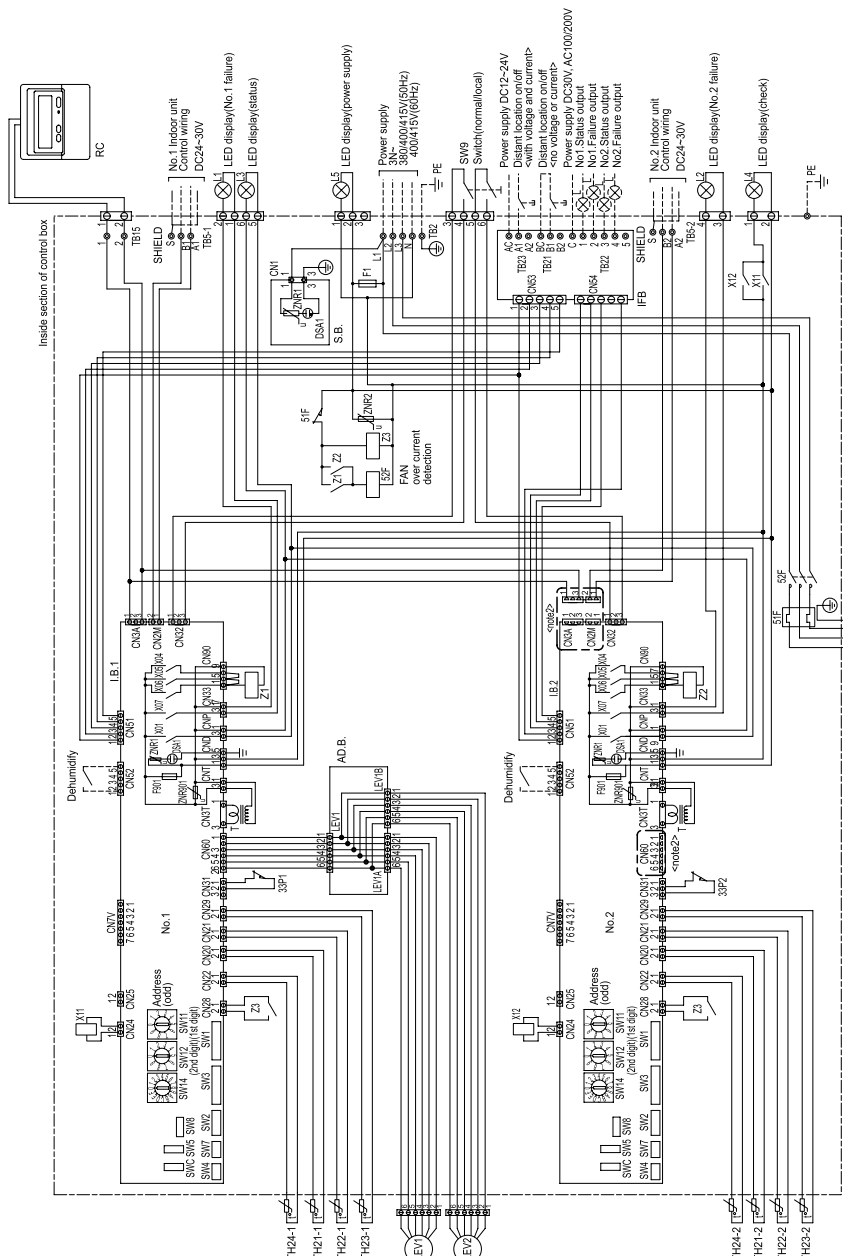

- Note:**
- The dotted lines show field wiring.
 - It is wiring for 1 refrigerant system at the time of shipping. Change wiring and SW2, 3, 4 (No.1&No.2) as this figure in field when you change it to 2 refrigerant circuit.
 - Set up the address of No. 1 board in the odd number, and set up the address of No.2 board in the even number. But, set up the address of the No.2 board in the No.1 board + 1.
 - The outdoor unit to which the indoor unit is connected with the transmission line, the address of the outdoor unit should be the indoor unit +50.
 - Mark ⊕ indicates terminal bed, ⊖ connector, ⊞ board insertion connector or fastening connector of control board.

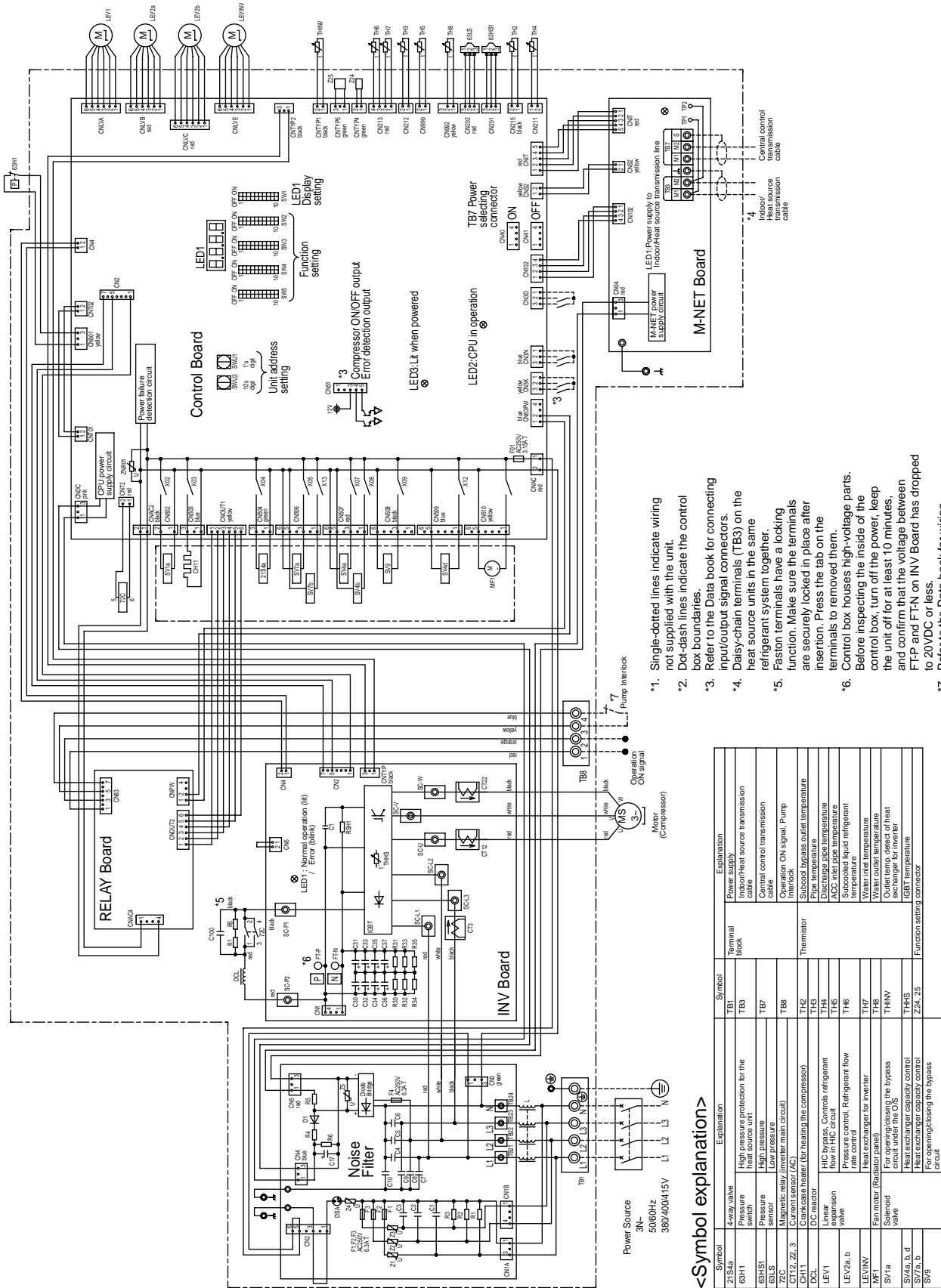

- *1. Single-dotted lines indicate wiring not supplied with the unit.
- *2. Dot-dash lines indicate the control box boundaries.
- *3. Refer to the Data book for connecting input/output signal connectors.
- *4. Daisy-chain terminals (TB3) on the heat source units in the same refrigerant system together.
- *5. Faston terminals have a locking function. Make sure the terminals are securely locked in place after insertion. Press the tab on the terminals to removed them.
- *6. Before inspecting the inside of the control box, turn off the power, keep the unit off for at least 10 minutes, and confirm that the voltage between F-T-P and F-T-N on INV Board has dropped to 20V/DC or less.
- *7. Refer to the Data book for wiring terminal block for Pump Interlock (TB8).

<Symbol explanation>

Symbol	Explanation	Symbol	Explanation
Z1S4-a	4-way valve	TE1	Power supply
BH1	Pressure switch	TE3	Indoor/Heat source transmission cable
GN1S1	High pressure sensor	TE7	Line control transmission cable
ZC	Magnetic relay (liner for main circuit)	TE8	Operation ON signal, Pump Interlock
CT12, 22, 3	Current sensor (AC)	TH2	Subcool Bypass outlet temperature
CH1	Crackcase heater (for heating the compressor)	TH3	Pipe temperature
DC1	DC reactor	TH4	Discharge pipe temperature
LEV1	Linear expansion valve	TH5	ACCL inner pipe temperature
LEV2a, b	HIC bypass. Controls refrigerant flow in HIC circuit	TH6	Refrigerant liquid temperature
LEV3	Linear expansion valve	TH7	Water inlet temperature
MF1	Fan motor (Radiator panel)	TH8	Water outlet temperature
SV1a	Solenoid valve	THIN	Outlet temp. direct of heat exchanger for inverter
SV2a, b, d	Heat exchanger capacity control	THS	IGBT temperature
SV7a, b	Heat exchanger capacity control	Z24, 25	Function setting connector
SV9	For opening/closing the bypass circuit		

5. Refrigerant Circuit Diagram And Thermal Sensor

Outdoor Unit : PUHY-P250YHM-A

Indoor Unit : PFD-P250VM-E

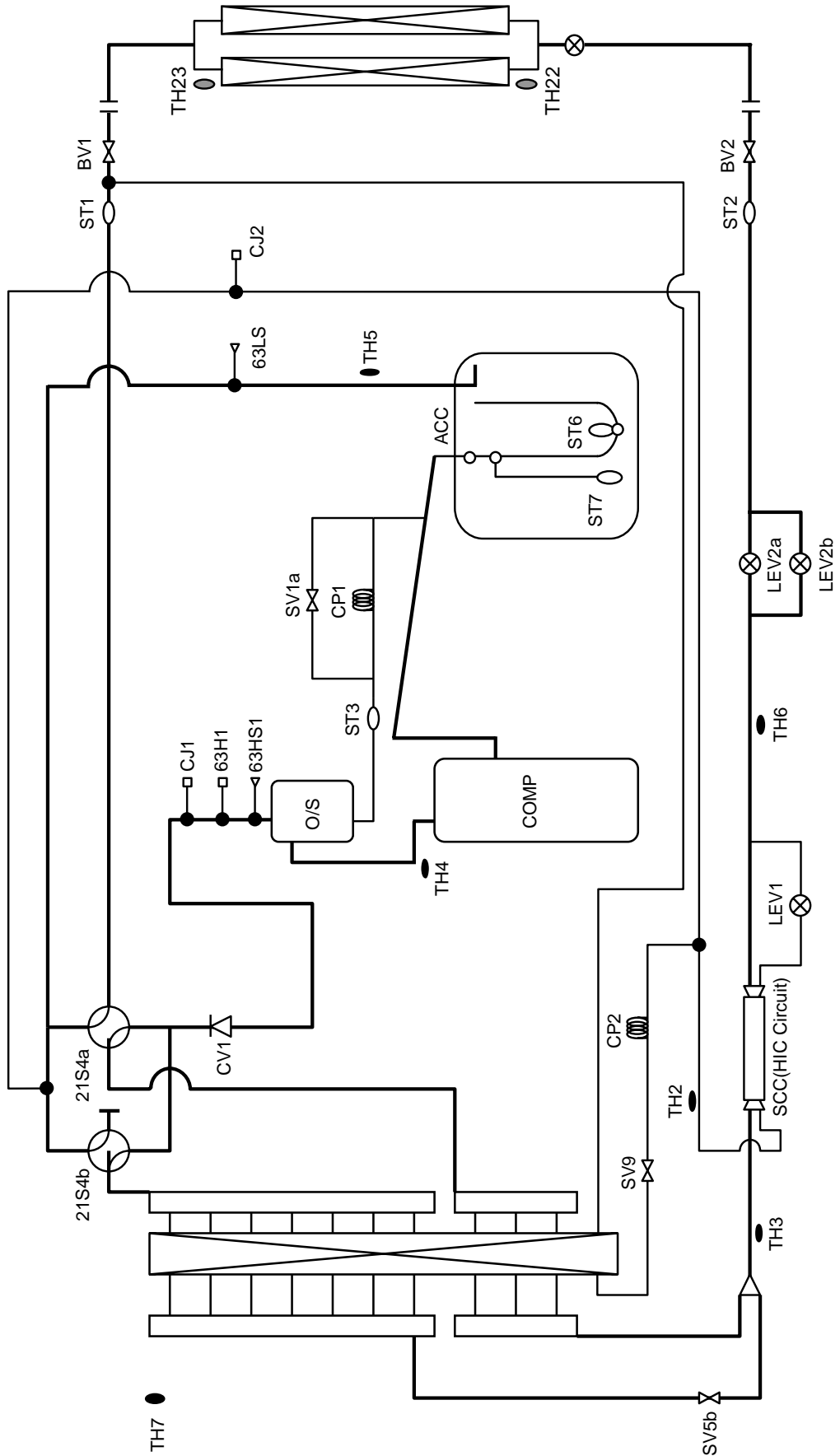

Outdoor Unit : PUHY-P250YHM-A x 2
 Indoor Unit : PFD-P500VM-E

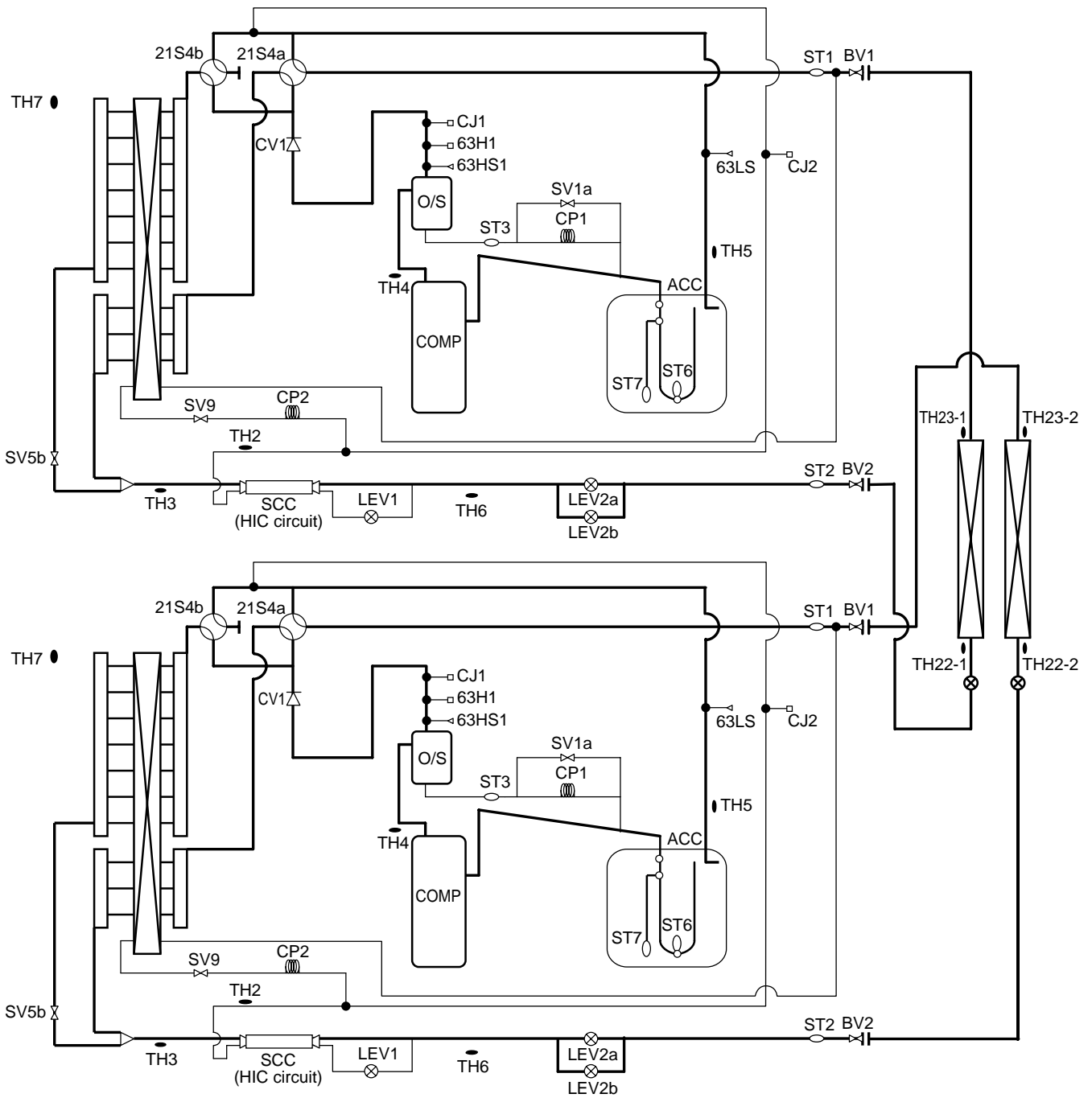

Outdoor Unit : PUHY-P500YSHM-A

Indoor Unit : PFD-P500VM-E

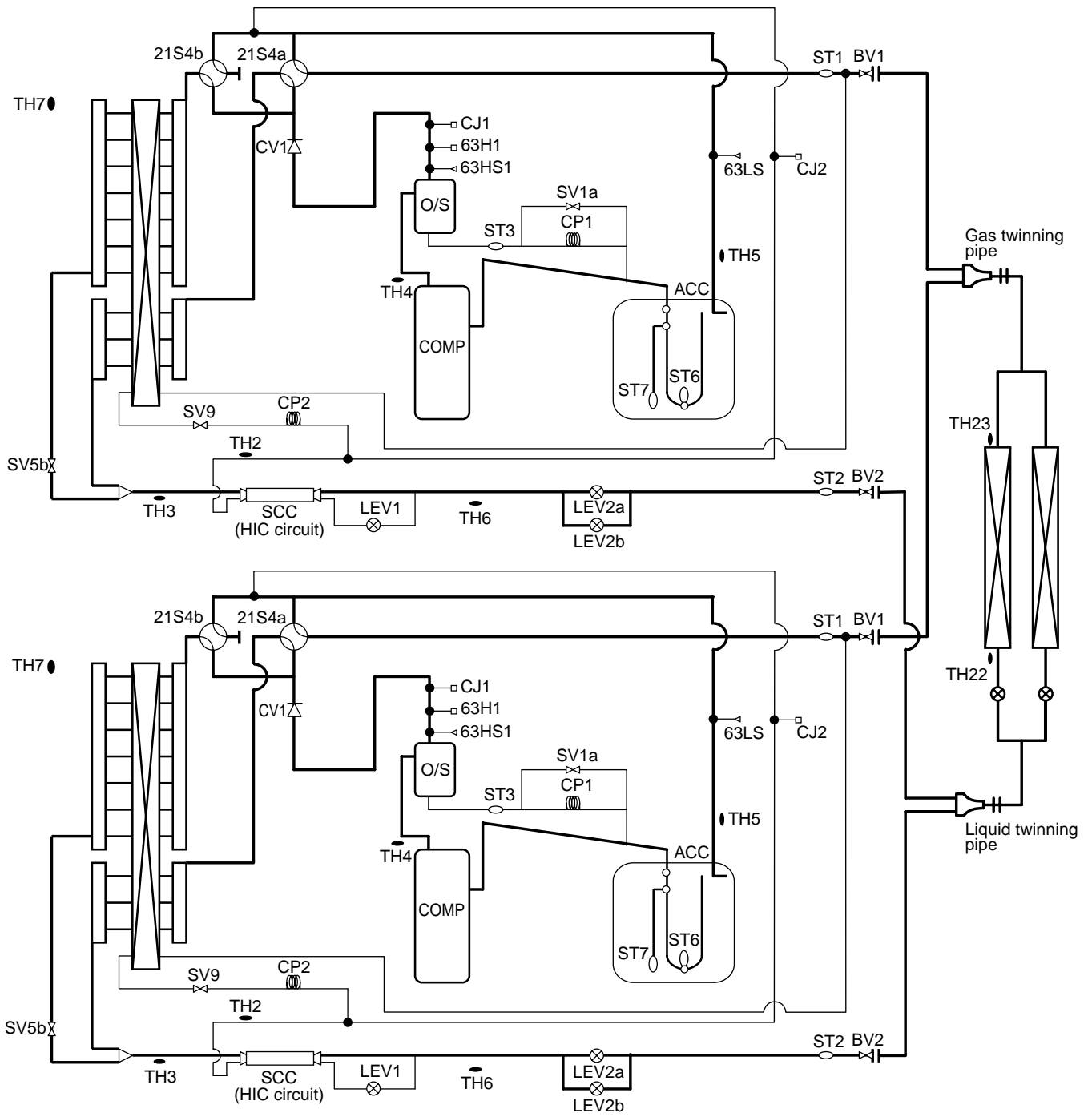

Heat source Unit : PQHY-P250YHM-A

Indoor Unit : PFD-P250VM-E

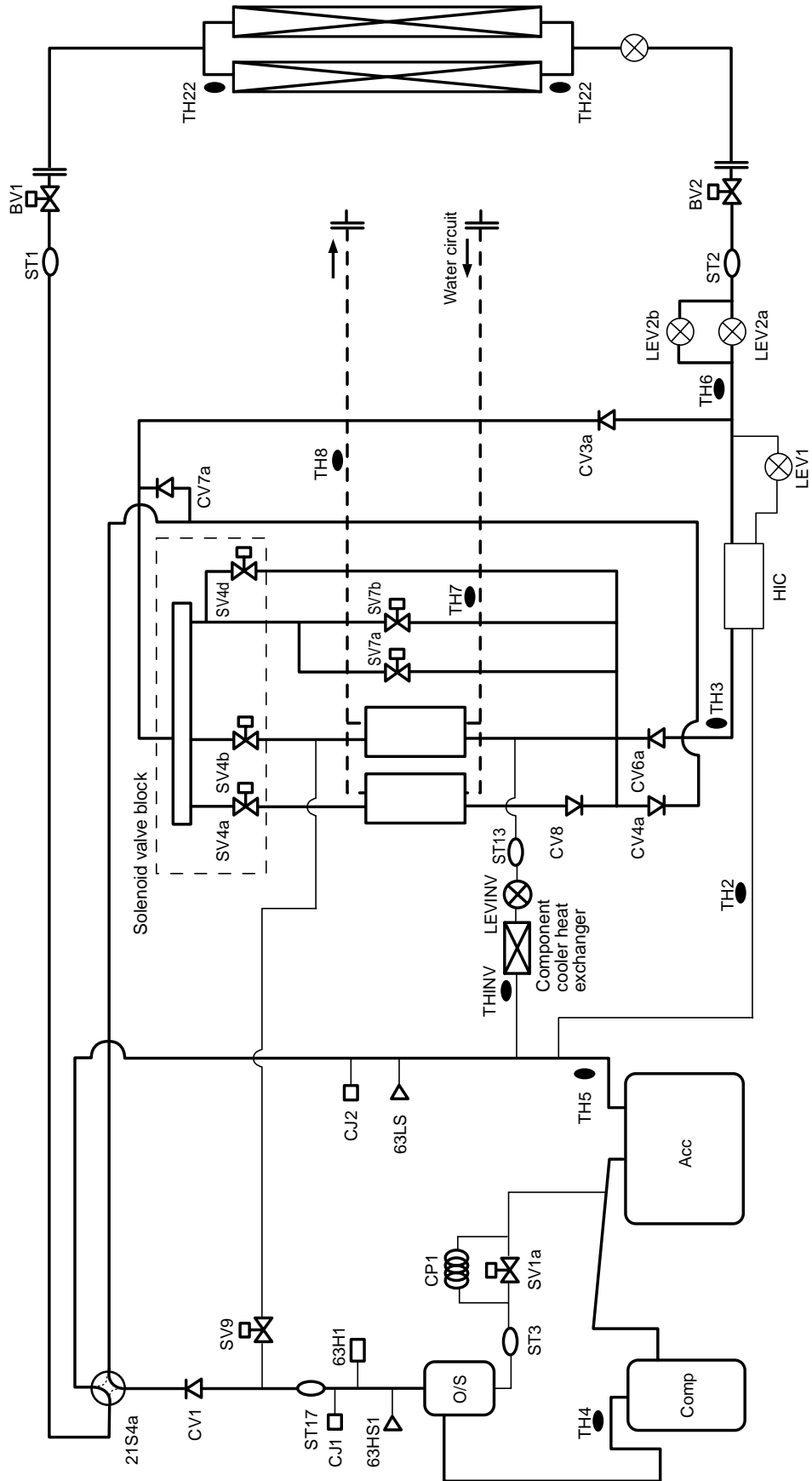

Heat source Unit : PQHY-P250YHM-A x 2
 Indoor Unit : PFD-P500VM-E

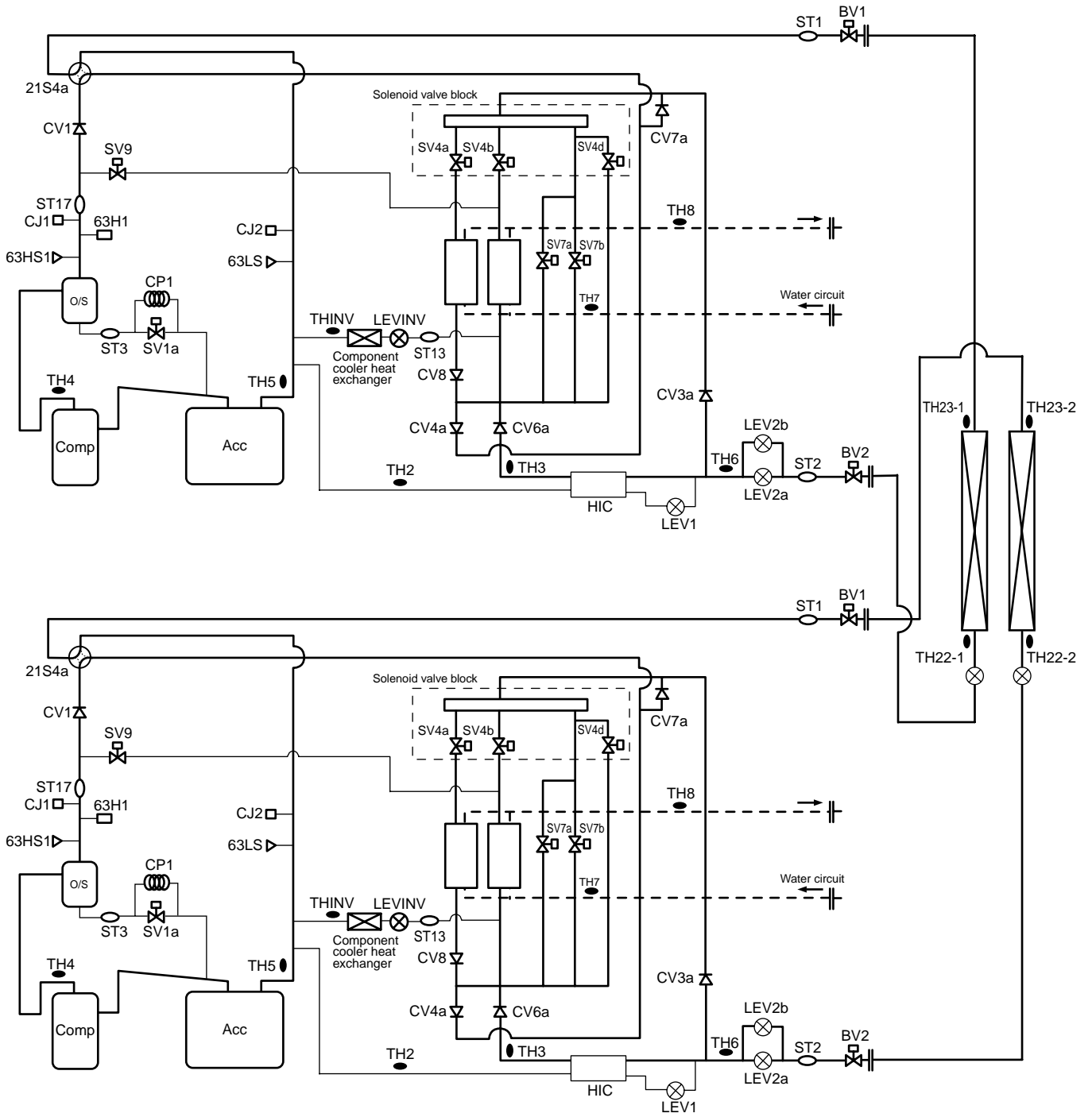

6. Optional Parts

(1) Outdoor unit

■ Outdoor twinning kit

For PUHY-P-YSHM, following optional Outdoor Twinning Kit is needed to use to combine to refrigerant flows of its PUHY-P-YHM. Details of selecting the proper kit should be referred to the System Design Section.

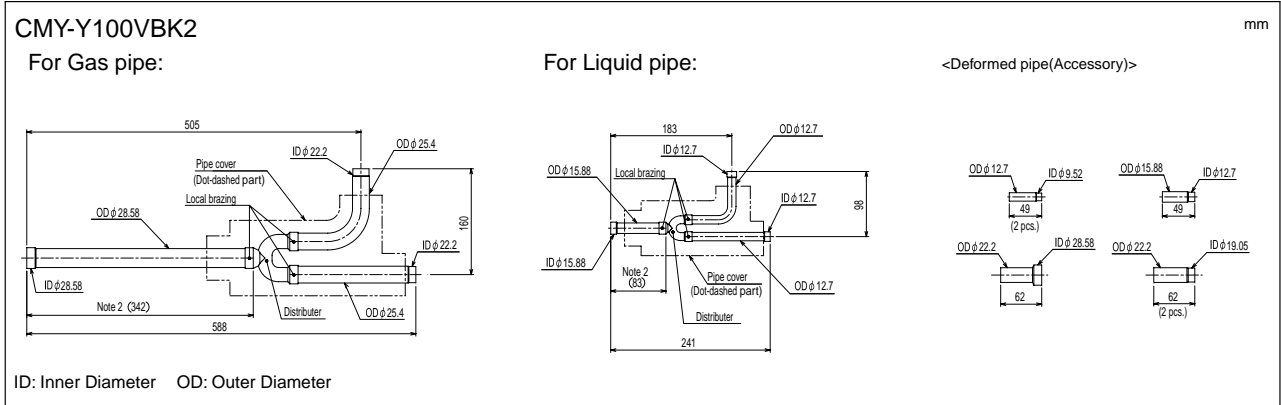

Note 1. Reference the attitude angle of the branch pipe below the fig.

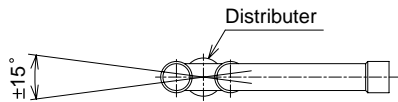

The angle of the branch pipe is within $\pm 15^\circ$ against the ground.

2. Use the attached pipe to braze the port-opening of the distributor.
3. Pipe diameter is indicated by inside diameter.

7. Controller

(1) MA remote controller

PAR-21MAA : built-in the indoor unit.

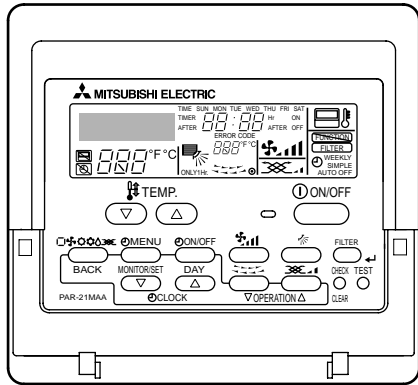

- Dot matrix liquid crystal screen displays complete operating status.
- Digital display lets you set temperature in 1°C/°F increments.
- Weekly Timer: up to 8 ON/OFF/Temperature Settings can be made per day. The time can be set in 1-minute increments. The setting is kept in nonvolatile memory. No need to worry about resetting at power failure.
- Equipped with a thermostat sensor in the remote controller that makes possible more comfortable room temperature control.
- Ability to limit the set temperature (upper and lower temperature can be set.)
- Ability to restrict setting changes (either all changes or all except ON/OFF)
- Constantly monitors for malfunctions in the system, and is equipped with a "self-diagnosis function" that lets you know by error code immediately when a malfunction occurs.
- Dimensions: 130(W) x120(H) x 19(D) mm

■ Functions

□:Each unit ○:Each group ●:Each block
△:Each floor ⊕:Collective ×:Not available

Item	Description	Operations	Display
ON/OFF	Run and stop operation for a single group	○	○
Operation mode switching	Switches between Cool / Fan / Heat. Operation modes vary depending on the air conditioner unit.	○	○
Temperature setting	Sets the temperature for a single group Range of temperature setting Cool : 19°C- 30°C (14°C - 30°C) [66°F- 86°F] ([57°F - 86°F]) Heat : 17°C- 28°C (17°C - 28°C) [68°F- 82°F] ([68°F - 82°F]) () In case of using middle-temperature on PDFY, PEFY-VML/VMR/VMS/VMH-E by setting DipSW7-1 to ON. Yet, PEFY-P-VMH-E-F is excluded.	○	○
Weekly scheduler	ON/OFF/Temperature setting can be done up to 8 times one day in the week. The time can be set by the minute.	○	○
Permit / Prohibit local operation	Individually prohibit operation of each local remote control function (Start/Stop, Change operation mode, Set temperature, Reset filter). *1: When the local remote controller inactivation command is received from the master system controller, "E" is displayed.	×	*1 ○
Prohibition/permission of specified mode (Cooling prohibited /heating prohibited /cooling-heating prohibited)	By the setting from System Controller, the operation for the following modes is prohibited. At cooling prohibited : Cool At heating prohibited : Heat At cooling-heating prohibited : Cool, Heat	×	○
Indoor unit intake temperature	Measures the intake temperature of the indoor unit when the indoor unit is operating.	×	○
Error	When an error is currently occurring on an air conditioner unit, the afflicted unit and the error code are displayed.	×	□
Test run	This operates air conditioner units in test run mode.	○	○
Function to limit the setting range of room temperature (Set temperature range limit)	Set temperature range limit to cooling, heating, or auto mode.	○	○
Easy-to-operate simplified locking function (Auto lock function)	Setting/releasing of simplified locking for remote control switch can be performed. - Locking of all switches - Locking of all switches except Start/Stop switch	○	○

■ External dimension

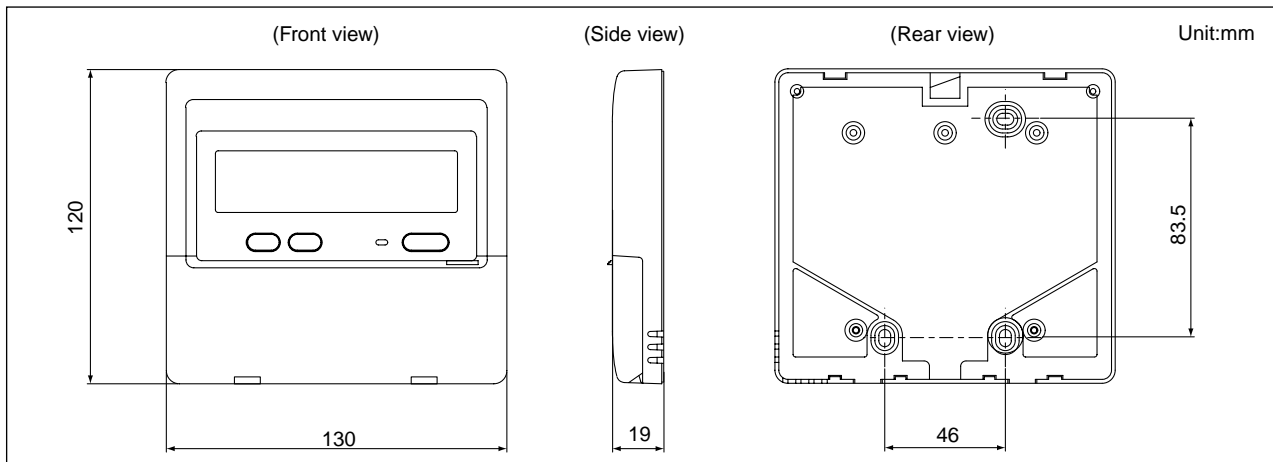

III. Product Data

1. Capacity Curves

(1) Correction by temperature

■ PUHY-P250YHM-A, PUHY-P500YSHM-A

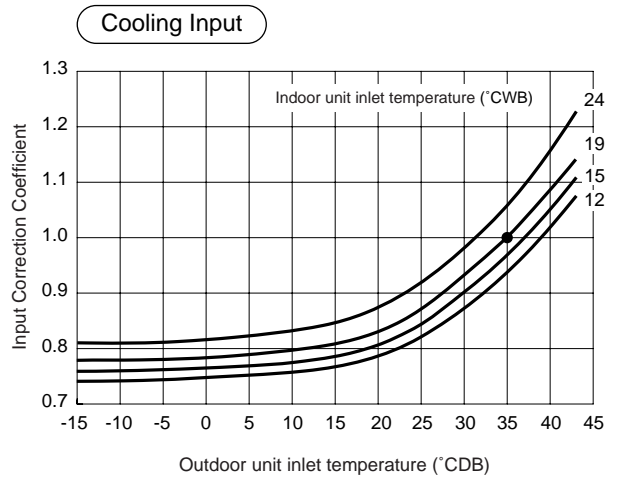
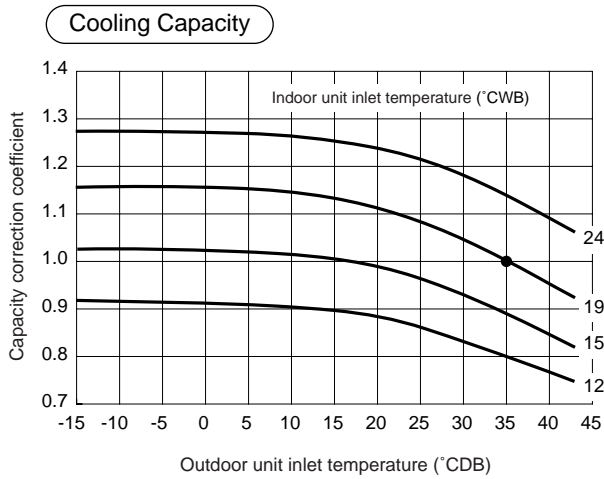

※ The correction curves indicate the values measured at the point where the compressor was operated at its maximum capacity.

※ ● indicates the standard value.

■ PQHY-P250YHM-A

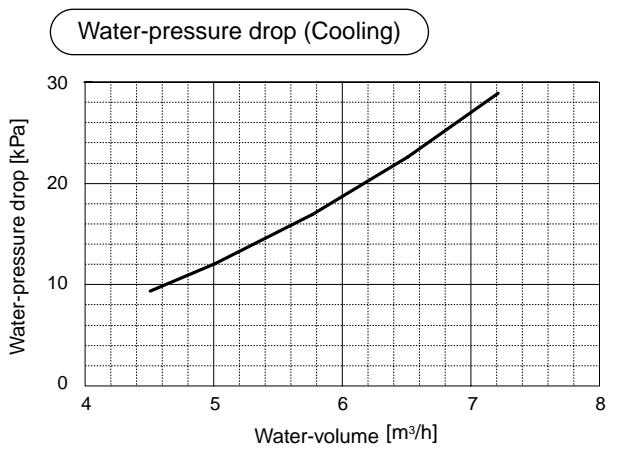
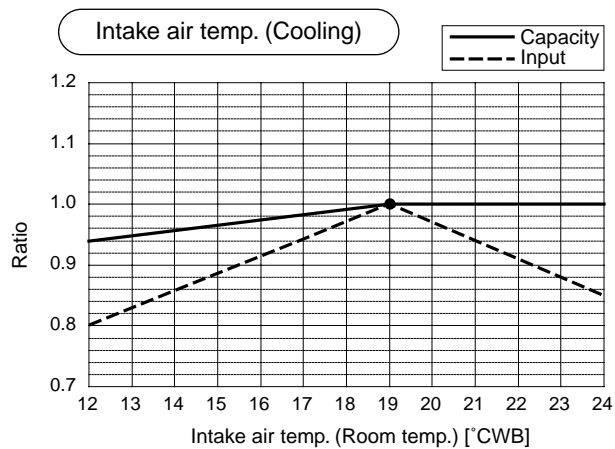
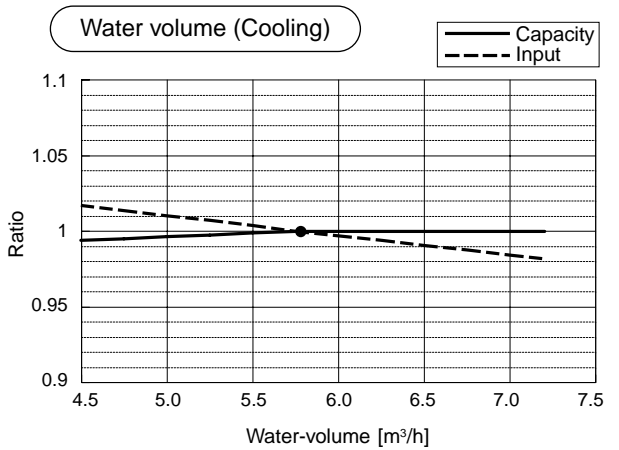
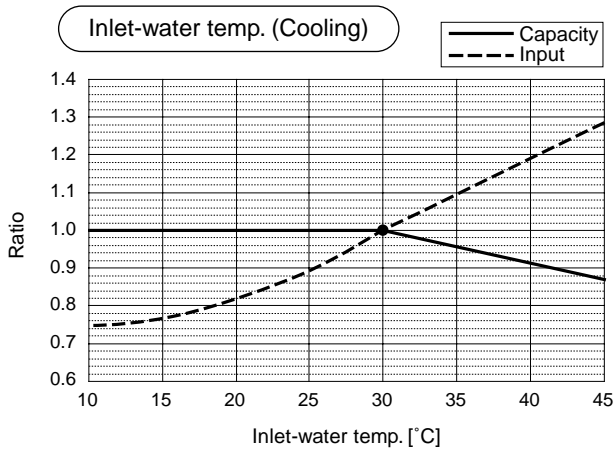

※ ● indicates the standard value.

(2) Part Load Performance

■ PFD unit +PUHY-P250YHM-A, PUHY-P500YSHM-A

● 10HP System

Indoor Unit : PFD-P250VM-E
Outdoor Unit : PUHY-P250YHM-A

Outdoor unit inlet temp. (°CDB)	Cooling Capacity (kW)	System Power input (kW)						
		100% Capacity	90% Capacity	80% Capacity	70% Capacity	60% Capacity	50% Capacity	40% Capacity
40 °C	26.6	10.05	8.75	7.68	6.79	6.08	5.50	5.04
35 °C	28.0	9.30	8.11	7.18	6.41	5.82	5.13	4.60
30 °C	29.4	8.65	7.61	6.81	6.17	5.50	4.94	4.52
25 °C	30.2	8.10	7.21	6.56	6.00	5.38	4.89	4.50
20 °C	31.1	7.72	6.92	6.26	5.74	5.27	4.85	4.47
15 °C	31.6	7.54	6.87	6.31	5.80	5.35	4.94	4.56

* Indoor air temperature condition: 27°CDB/19°CWB

● 20HP System

Indoor Unit : PFD-P500VM-E
Outdoor Unit : PUHY-P250YHM-A × 2, PUHY-P500YSHM-A

Outdoor unit inlet temp. (°CDB)	Cooling Capacity (kW)	System Power input (kW)							
		100% Capacity	90% Capacity	80% Capacity	70% Capacity	60% Capacity	50% Capacity	40% Capacity	30% Capacity
40 °C	53.2	20.09	17.46	15.24	13.49	12.08	10.94	10.07	8.37
35 °C	56.0	18.60	16.19	14.30	12.77	11.51	10.11	9.05	8.06
30 °C	58.8	17.30	15.24	13.58	12.24	10.79	9.76	8.92	7.68
25 °C	60.5	16.19	14.47	13.06	11.79	10.59	9.67	8.79	7.55
20 °C	62.2	15.44	13.88	12.53	11.42	10.48	9.64	8.52	7.49
15 °C	63.3	15.07	13.83	12.63	11.58	10.67	9.84	8.62	7.64

* Indoor air temperature condition: 27°CDB/19°CWB

■ PFD unit +PQHY-P250YHM-A

● 10HP System

Indoor Unit : PFD-P250VM-E
Heat source Unit : PQHY-P250YHM-A

Outdoor unit inlet temp. (°CDB)	Cooling Capacity (kW)	System Power input (kW)					
		100% Capacity	90% Capacity	80% Capacity	70% Capacity	60% Capacity	50% Capacity
40 °C	25.4	9.00	8.02	7.24	6.59	6.08	5.71
35 °C	26.7	8.50	7.59	6.87	6.28	5.80	5.46
30 °C	28.0	7.95	7.13	6.47	5.93	5.50	5.20
25 °C	28.0	7.37	6.64	6.05	5.57	5.19	4.91
20 °C	28.0	6.95	6.28	5.75	5.31	4.95	4.70
15 °C	28.0	6.69	6.06	5.55	5.14	4.81	4.57

* Indoor air temperature condition: 27°CDB/19°CWB

● 20HP System

Indoor Unit : PFD-P500VM-E
Heat source Unit : PQHY-P250YHM-A × 2

Outdoor unit inlet temp. (°CDB)	Cooling Capacity (kW)	System Power input (kW)							
		100% Capacity	90% Capacity	80% Capacity	70% Capacity	60% Capacity	50% Capacity	40% Capacity	30% Capacity
40 °C	50.8	17.99	16.04	14.47	13.19	12.16	11.43	9.74	8.58
35 °C	53.4	16.99	15.19	13.74	12.55	11.61	10.93	9.37	8.30
30 °C	56.0	15.90	14.26	12.95	11.87	11.01	10.39	8.97	8.00
25 °C	56.0	14.74	13.28	12.10	11.14	10.37	9.82	8.55	7.69
20 °C	56.0	13.91	12.57	11.49	10.61	9.91	9.40	8.25	7.45
15 °C	56.0	13.37	12.11	11.10	10.27	9.61	9.14	8.35	7.31

* Indoor air temperature condition: 27°CDB/19°CWB

(3) Correction by refrigerant piping length

To obtain a decrease in cooling/heating capacity due to refrigerant piping extension, multiply by the capacity correction factor based on the refrigerant piping equivalent length in the table below.

■ PUHY-P250YHM-A, PUHY-P500YSHM-A, PQHY-P250YHM-A

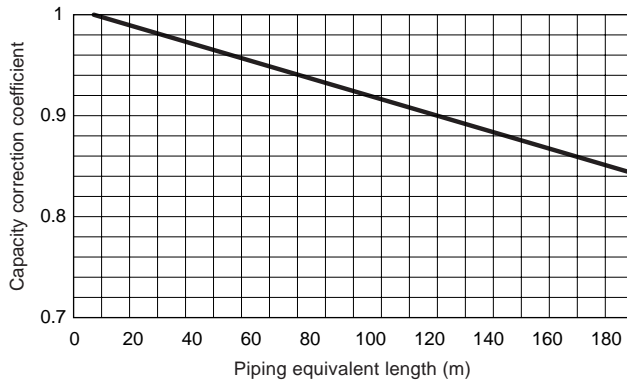

• How to obtain piping equivalent length

1. PUHY-P250YHM-A, PQHY-P250YHM-A

Equivalent length = (Actual piping length to the farthest indoor unit) + (0.42 × number of bent on the piping) m

2. PUHY-P500YSHM-A

Equivalent length = (Actual piping length to the farthest indoor unit) + (0.50 × number of bent on the piping) m

(4) Correction by indoor unit airflow rate

■ PFD-P250VM-E

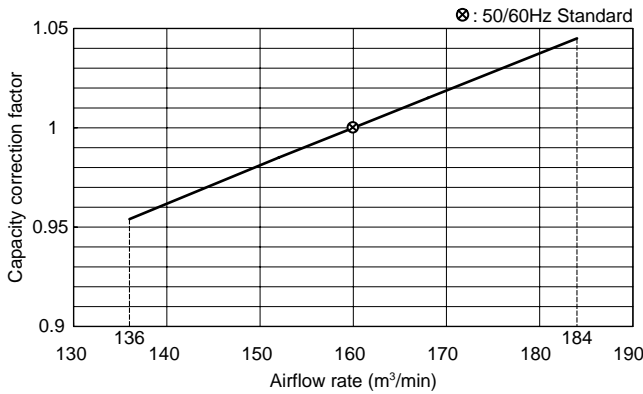

■ PFD-P500VM-E

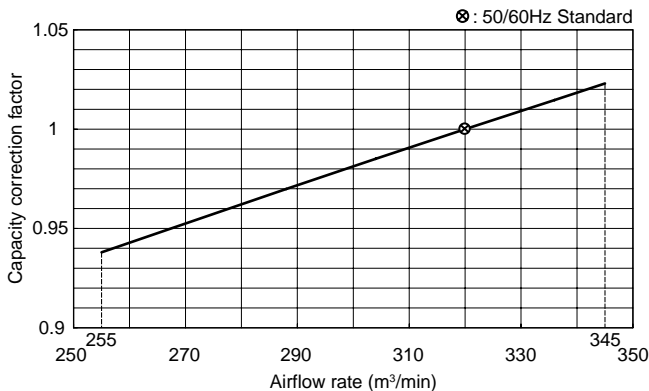

(5) SHF Curves

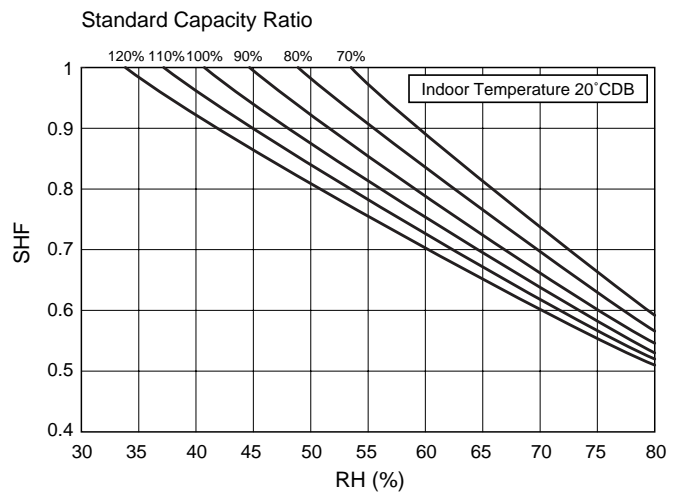
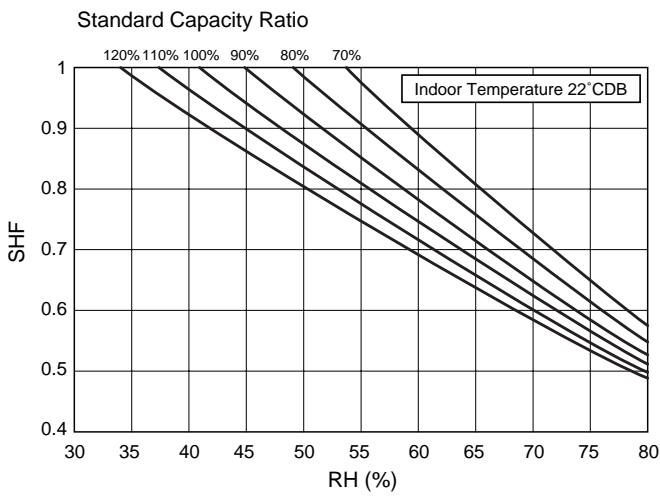
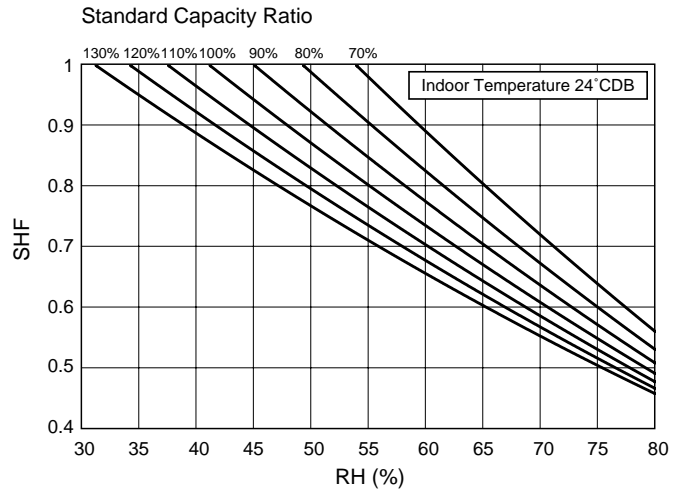
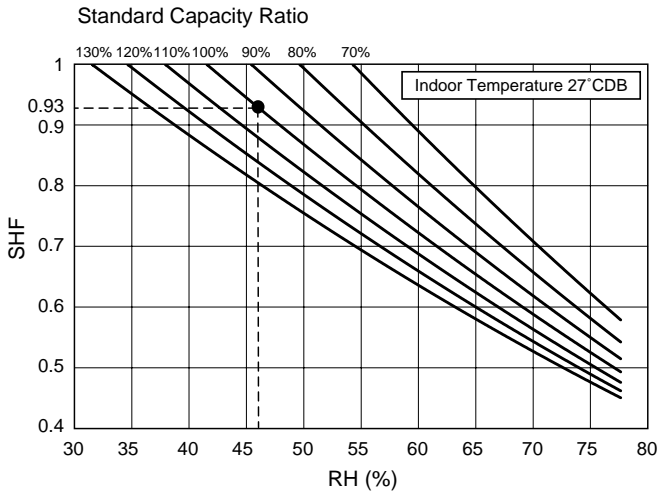

Operation Temperature Range : Indoor : 12°CWB~24°CWB
 Outdoor : -15°CDB~43°CDB
 (RH : 30~80%)

Standard Point "●" : Indoor : 27°CDB / 19°CWB
 Outdoor : 35°CDB / -

2. Sound Levels

(1) Measurement condition

■ Indoor unit

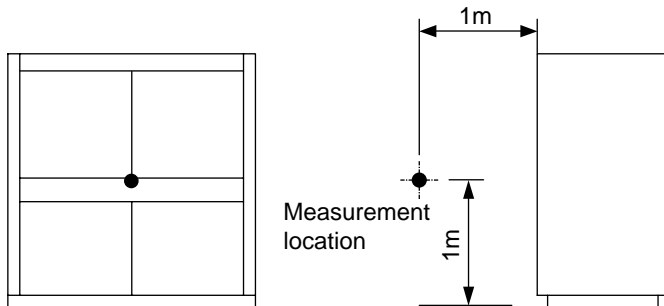

Series	Sound pressure level (dB [Type A])
PFD-P250VM-E	59
PFD-P500VM-E	63

■ Outdoor unit

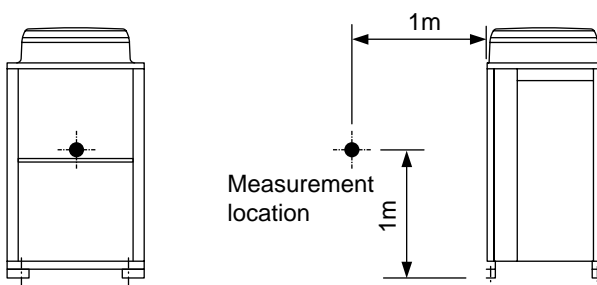

Series	Sound pressure level (dB [Type A])
PUHY-P250YHM-A	57

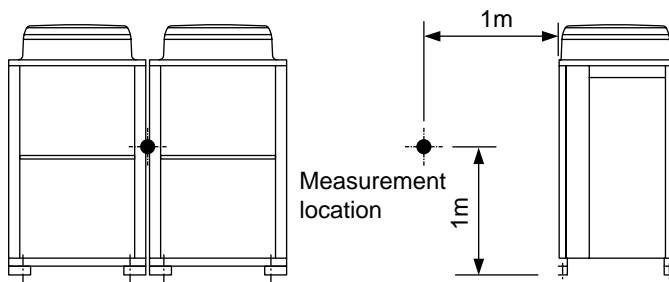

Series	Sound pressure level (dB [Type A])
PUHY-P500YSHM-A	60

■ Heat source unit

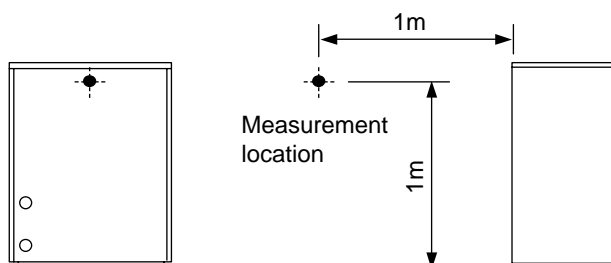

Series	Sound pressure level (dB [Type A])
PQHY-P250YHM-A	49

(2) NC Curves

PFD-P250VM-E (External static pressure 120Pa)

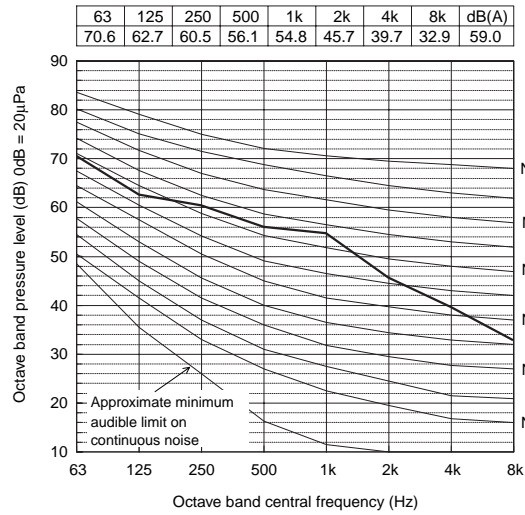

PFD-P500VM-E (External static pressure 120Pa)

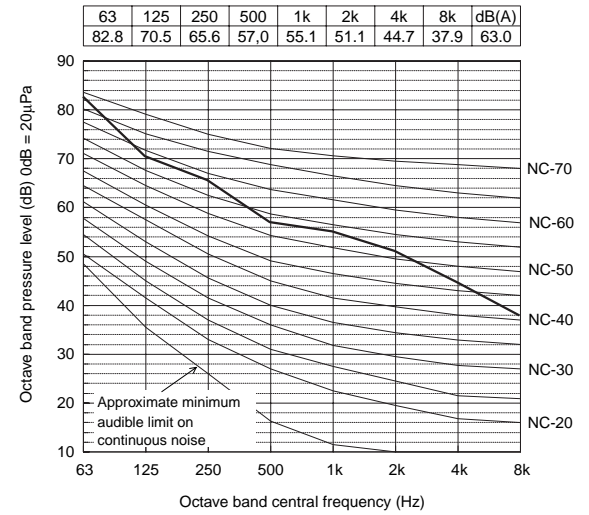

PUHY-P250YHM-A (External static pressure 0Pa)

	63	125	250	500	1k	2k	4k	8k	dB(A)
Standard	59.0	62.0	60.0	54.0	50.5	46.0	41.0	35.0	57.0
Low Noise Mode	58.0	53.5	44.0	39.0	36.5	32.5	31.0	24.5	44.0

When Low Noise Mode is set, the A/C system's capacity is limited. The system could return to normal operation from Low Noise Mode automatically in the case that the operation condition is severe.

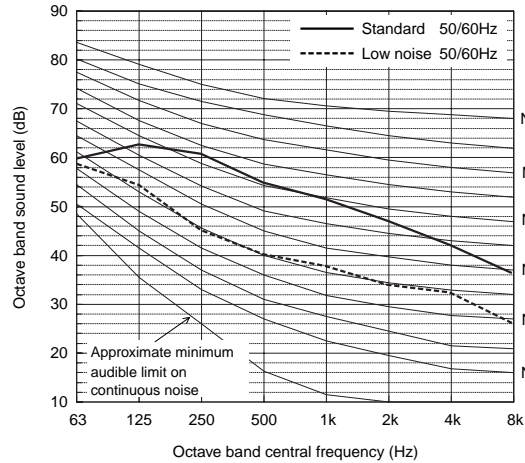

PUHY-P500YSHM-A (External static pressure 0Pa)

	63	125	250	500	1k	2k	4k	8k	dB(A)
Standard	62.0	65.0	63.0	57.0	53.5	49.0	44.0	38.0	60.0
Low Noise Mode	61.0	56.5	47.0	42.0	39.5	35.5	34.0	27.5	47.0

When Low Noise Mode is set, the A/C system's capacity is limited. The system could return to normal operation from Low Noise Mode automatically in the case that the operation condition is severe.

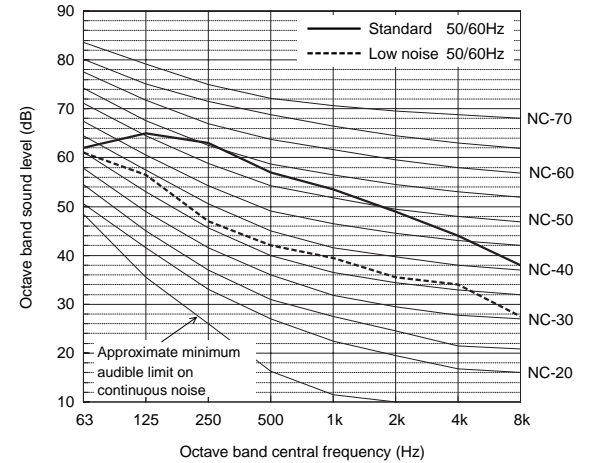

PQHY-P250YHM-A (External static pressure 0Pa)

	63	125	250	500	1k	2k	4k	8k	dB(A)
Standard	61.0	54.0	48.0	43.5	42.0	39.0	43.0	32.5	49.0
Low noise mode	60.5	53.0	47.5	43.0	38.0	37.0	40.5	28.5	47.0

When Low noise mode is set, the A/C system's capacity is limited. The system could return to normal operation from Low noise mode automatically in the case that the operation condition is severe.

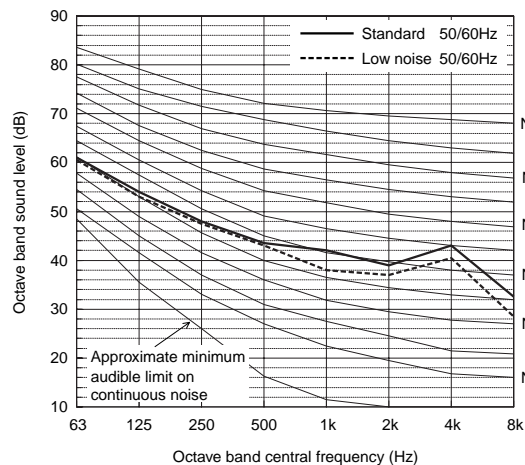

3. Fan Characteristics Curves

●PFD-P250VM-E

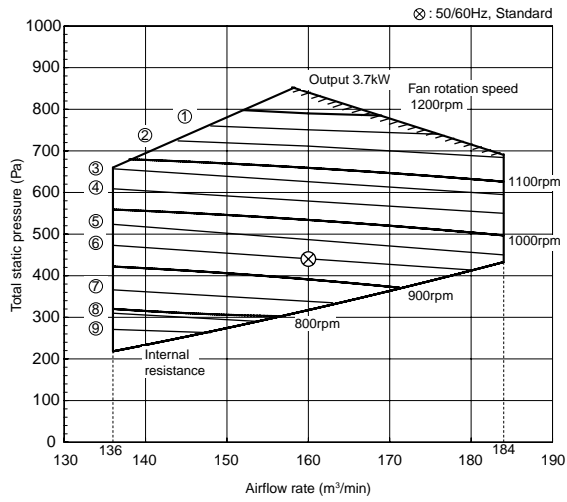

No.	Rotational speed(rpm)	50Hz			60Hz		
		Motor pulley	Fan pulley	V-belt	Motor pulley	Fan pulley	V-belt
①	1170	Ø160-B-2-28	Ø200-B-2-42	B48	Ø165-B-2-28	Ø250-B-2-42	B52
②	1140	Ø165-B-2-28	Ø212-B-2-42	B49	Ø180-B-2-28	Ø280-B-2-42	B55
③	1080	Ø165-B-2-28	Ø224-B-2-42	B50	Ø170-B-2-28	Ø280-B-2-42	B54
④	1040	Ø165-B-2-28	Ø236-B-2-42	B51	Ø165-B-2-28	Ø280-B-2-42	B54
⑤	973	Ø165-B-2-28	Ø250-B-2-42	B52	Ø165-B-2-28	Ø300-B-2-42	B55
⑥	930	Ø170-B-2-28	Ø280-B-2-42	B54	Ø160-B-2-28	Ø315-B-2-42	B56
⑦	845	Ø160-B-2-28	Ø280-B-2-42	B54	Ø170-B-2-28	Ø355-B-2-42	B60
⑧	797	Ø170-B-2-28	Ø315-B-2-42	B57	Ø160-B-2-28	Ø355-B-2-42	B59
⑨	748	Ø160-B-2-28	Ø315-B-2-42	B56	-	-	-

Note1 Pulley and V-belt is procured on site.
 Note2 Mitsubishi Electric shall not be held responsible for the pulley modified on site.

●PFD-P500VM-E

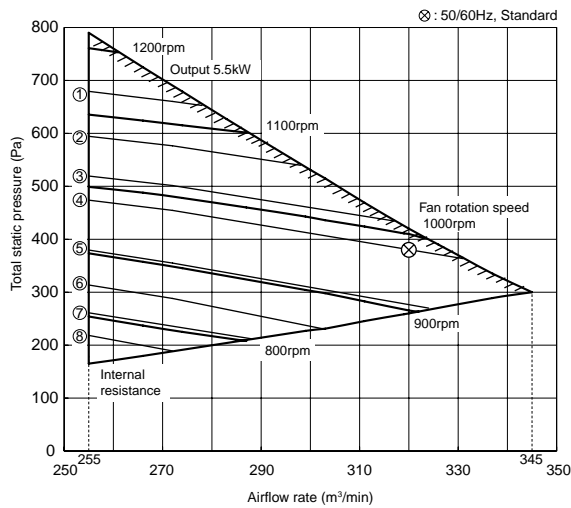

No.	Rotational speed(rpm)	50Hz			60Hz		
		Motor pulley	Fan pulley	V-belt	Motor pulley	Fan pulley	V-belt
①	1135	Ø180-B-2-38	Ø236-B-2-42	B51	Ø160-B-2-38	Ø250-B-2-42	B50
②	1070	Ø180-B-2-38	Ø250-B-2-42	B51	Ø180-B-2-38	Ø300-B-2-42	B55
③	1015	Ø170-B-2-38	Ø250-B-2-42	B51	Ø160-B-2-38	Ø280-B-2-42	B52
④	978	Ø160-B-2-38	Ø250-B-2-42	B50	Ø160-B-2-38	Ø300-B-2-42	B54
⑤	905	Ø170-B-2-38	Ø280-B-2-42	B53	Ø160-B-2-38	Ø315-B-2-42	B55
⑥	850	Ø180-B-2-38	Ø315-B-2-42	B56	Ø170-B-2-38	Ø355-B-2-42	B58
⑦	803	Ø170-B-2-38	Ø315-B-2-42	B55	Ø160-B-2-38	Ø355-B-2-42	B58
⑧	780	Ø165-B-2-38	Ø315-B-2-42	B55	-	-	-

Note1 Pulley and V-belt is procured on site.
 Note2 Mitsubishi Electric shall not be held responsible for the pulley modified on site.

Shape of the pulley (unit : mm)

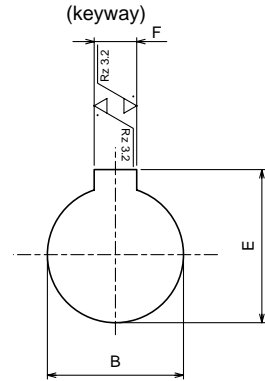
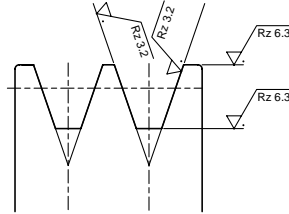
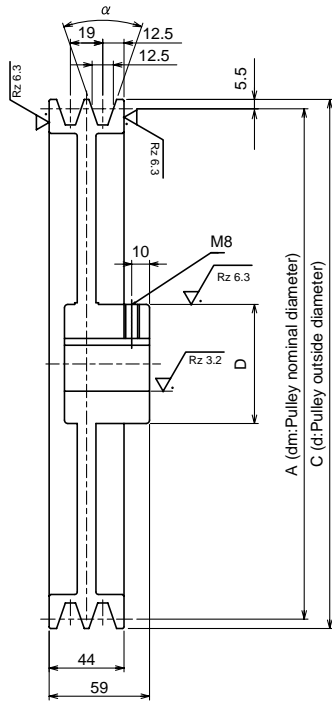

Belt	dm: Pulley nominal diameter	α
	$d_m \leq 160$	34°
	$161 < d_m \leq 200$	36°
	$201 < d_m$	38°

Motor pulley					
Nominal Diameter (A) <Ø>	Bore (B) <Ø>	Outside Diameter (C) <Ø>	(D) <Ø>	(E) <mm>	(F) <mm>
160	28	171	71	31.3	9
165		176	71	31.3	9
170		181	71	31.3	9
180		191	71	31.3	9
160	38	171	71	41.3	10
165		176	71	41.3	10
170		181	71	41.3	10
180		191	71	41.3	10

Fan pulley					
Nominal Diameter (A) <Ø>	Bore (B) <Ø>	Outside Diameter (C) <Ø>	(D) <Ø>	(E) <mm>	(F) <mm>
200	42	211	80	45.3	12
212		223	80	45.3	12
224		235	80	45.3	12
236		247	80	45.3	12
250		261	80	45.3	12
280		291	80	45.3	12
300		311	80	45.3	12
315		326	90	45.3	12
355		366	90	45.3	12

* Use long dog-point set screws.

Shape of the V belt (unit : mm)

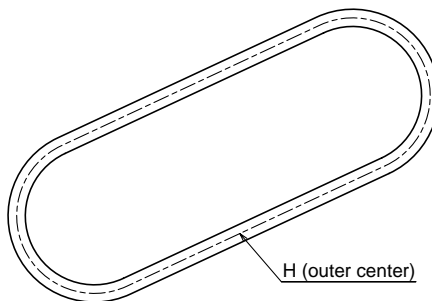
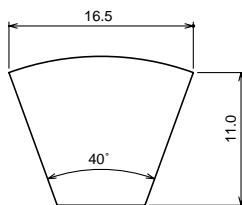

* Use a red V-belt.

- Horizontal pulley alignment and proper belt tension

- (1) The fan pulley and the motor pulley must be aligned to meet the criteria shown in Figure 1 and Table 1.
- (2) Set the tension for the V-belt so that the deflection force falls within the range as shown in Table 2.
- (3) After the belt has been broken in on the pulley (after 24 to 28 hours of operation), check the belt for looseness and adjust the belt tension as specified in step (2) above as necessary. When setting the tension for a new belt, set it to a value 1.15 times the deflection force W.
- (4) After the initial adjustment of the belt as described in step (3) above, readjust the belt tension every 2000 hours of operation. [The belt is due for replacement when the belt has been stretched by 2% of its original length, including the initial stretch of 1%. (Approx. 5000 hours of operation)]

Note: Apply Screwlock (not supplied) to the retention screw on the pulley to prevent the screw from loosening. Tighten the screw to the torque of 13.5 N·m. (Screwlock: Equivalent to ThreeBond 1322N)

(Table 1) Horizontal alignment of the pulley

Degree of parallelism Pulley	K (arc-minute)	Note
Cast iron pulley	10 or smaller	Equivalent to 3 mm of displacement per 1 m.

(Table 2) Belt tension

Model	Power source frequency [Hz]	Deflection force [W(N)]	Amount of deflection [mm]
PFD-P250VM-E	50	15.0 to 16.5	5.0 to 5.5
	60	14.5 to 15.5	
PFD-P500VM-E	50	20.0 to 22.5	5.0
	60	19.5 to 21.0	

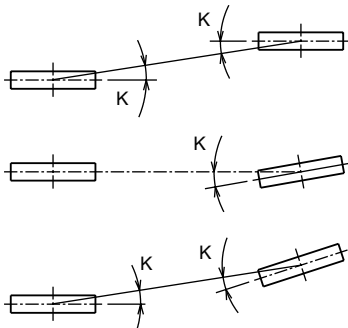

(Figure 1) Pulley's degree of parallelism

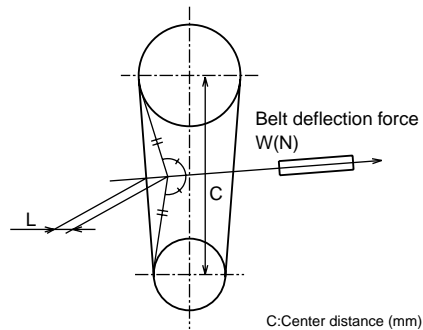

(Figure 2) Belt tension

IV. System Design

1. Piping Design

(1) PFD-P250VM-E

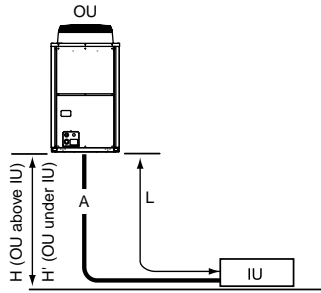

Fig.IV-1-(1)A : PUHY Piping Design

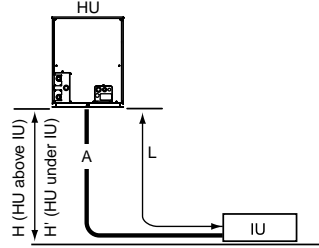

Fig.IV-1-(1)B : PQHY Piping Design

IU : Indoor unit , OU : Outdoor unit , HU: Heat source unit

Table : IV-1-(1)-1. Piping length (m)

Item	Piping in the figure	Max. length	Max. equivalent length
Farthest IU from OU/HU (L)	A	165	190
Height between OU/HU and IU (OU/HU above IU)	H	50	-
Height between OU/HU and IU (OU/HU under IU)	H'	40	-

OU: Outdoor Unit, IU: Indoor Unit, HU: Heat source Unit

Table : IV-1-(1)-2. Bent equivalent length "M"

Outdoor Model	M (m/bent)
PUHY-P250	0.42
PQHY-P250	0.42

Table : IV-1-(1)-3. Piping "A" size selection rule (mm)

Outdoor	Pipe(Liquid)	Pipe(Gas)
PUHY-P250	ø9.52 *1	ø22.20
PQHY-P250	ø9.52 *1	ø22.20

*1. A>=90m , ø12.70mm

Table : IV-1-(1)-4. Indoor unit piping size selection rule (mm)

Indoor Unit size	Pipe(Liquid)	Pipe(Gas)
P250	ø9.52	ø22.20

Note1. If the PUHY system is designed to use cooling mode under outdoor temperature 10°C, H'<=15m.

Note2. As bents cause pressure loss on transportation of refrigerant, fewer bents design is better;

Piping length needs to consider the actual length and equivalent length which bents are counted.
Equivalent piping length (m)=Actual piping length+ "M" x Quantity of bent.

(2) PFD-P500VM-E (two refrigerant circuit system)

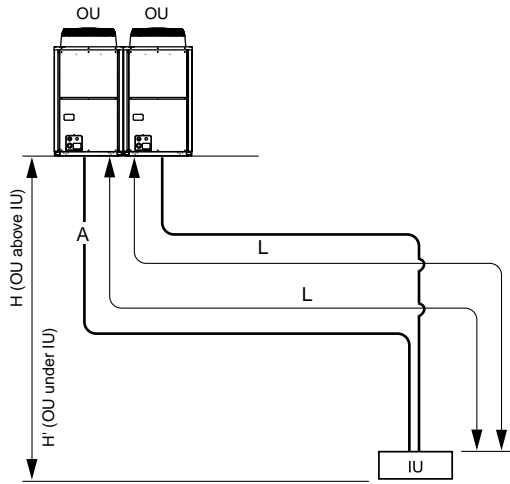

Fig.IV-1-(2)A : PUHY Piping Design

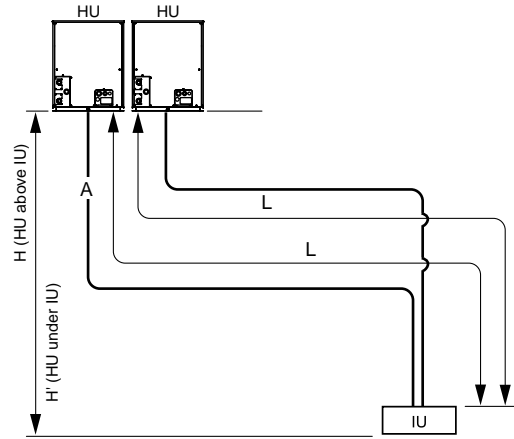

Fig.IV-1-(2)B : PQHY Piping Design

IU : Indoor unit , OU : Outdoor unit , HU: Heat source unit

Table : IV-1-(2)-1. Piping length (m)

Item	Piping in the figure	Max. length	Max. equivalent length
Farthest IU from OU/HU (L)	A	165	190
Height between OU/HU and IU (OU/HU above IU)	H	50	-
Height between OU/HU and IU (OU/HU under IU)	H'	40	-

OU: Outdoor Unit, IU: Indoor Unit, HU: Heat source Unit

Table : IV-1-(2)-2. Bent equivalent length "M"

Outdoor Model	M (m/bent)
PUHY-P250	0.42
PQHY-P250	0.42

Table : IV-1-(2)-3. Piping "A" size selection rule (mm)

Outdoor	Pipe(Liquid)	Pipe(Gas)
PUHY-P250	ø9.52 *1	ø22.20
PQHY-P250	ø9.52 *1	ø22.20

*1. A>=90m , ø12.70mm

Table : IV-1-(2)-4. Indoor unit piping size selection rule (mm)

Indoor Unit size	Pipe(Liquid)	Pipe(Gas)
P500	ø9.52	ø22.20

Note1. If the PUHY system is designed to use cooling mode under outdoor temperature 10°C, H'<=15m.

Note2. As bents cause pressure loss on transportation of refrigerant, fewer bents design is better;

Piping length needs to consider the actual length and equivalent length which bents are counted.
Equivalent piping length (m)=Actual piping length+ "M" x Quantity of bent.

(3) PFD-P500VM-E (single refrigerant circuit system)

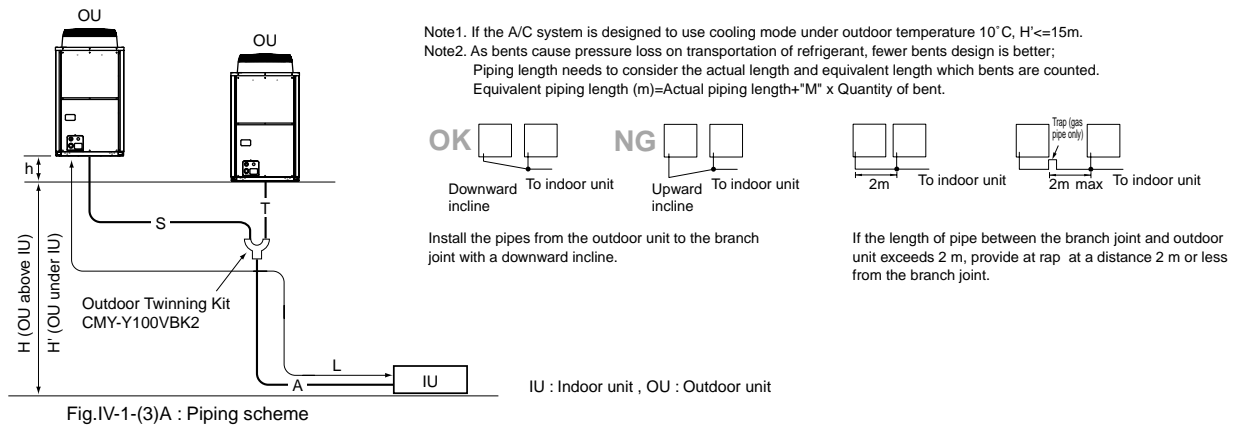

Table : IV-1-(3)-1. Piping length

Item	Piping in the figure	Max. length	Max. equivalent length
Distance between OU and OU	S+T	10	-
Height between OU and OU	h	0.1	-
Farthest IU from OU (L)	A	165	190
Height between OU and IU (OU above IU)	H	50	-
Height between OU and IU (OU above IU)	H'	40	-

OU: Outdoor Unit, IU: Indoor Unit

Table : IV-1-(3)-2. Bent equivalent length "M"

Outdoor Model	M (m/bent)
PUHY-P500	0.50

Table : IV-1-(3)-3. Piping "A" size selection rule

Outdoor	Pipe(Liquid)	Pipe(Gas)
CMY-Y100VBK2	ø15.88	ø28.58

CMY-Y100VBK2; PUHY-P500

Table : IV-1-(3)-4. Indoor unit piping size selection rule

Indoor Unit size	Pipe(Liquid)	Pipe(Gas)
P500	ø15.88	ø28.58

(4) Refrigerant charging calculation

Sample connection : with PFD-P500VM-E (single refrigerant circuit)

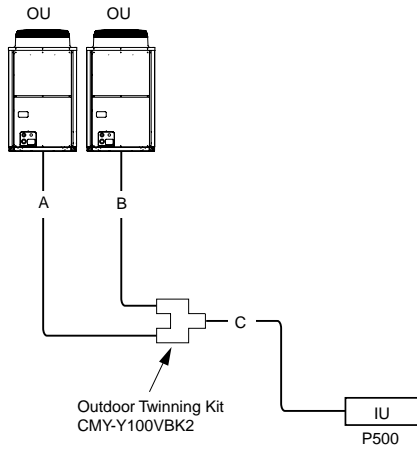

■ Amount of refrigerant to be charged

Refrigerant for extended pipes (field piping) is not factory-charged to the outdoor unit. Add an appropriate amount of refrigerant for each pipe on site.

Record the size of each liquid pipe and the amount of refrigerant that was charged on the outdoor unit for future reference.

■ Calculating the amount of refrigerant to be charged

- The amount of refrigerant to be charged is calculated with the size of the on-site-installed liquid pipes and their length.
- Calculate the amount of refrigerant to be charged according to the formula below.
- Round up the calculation result to the nearest 0.1kg. (i.e., 16.08 kg = 16.1 kg)

<Amount of refrigerant to be charged>

■ Calculating the amount of refrigerant to be charged

Total length of $\phi 15.88$ liquid pipe x 0.2	+	Total length of $\phi 12.7$ liquid pipe x 0.12	+	Total length of $\phi 9.52$ liquid pipe x 0.06	+	Model connected indoorunit	Amount for the indoor unit
(m)x0.2(kg/m)		(m)x0.12(kg/m)		(m)x0.06(kg/m)		P250 model	2.0kg
						P500 model	4.0kg ※2 kg x 2 when connected to a system with two outdoor units

■ Amount of factory-charged refrigerant

Model	Charged amount
PUHY-P250YHM-A	9.0kg
PQHY-P250YHM-A	5.0kg

■ Sample calculation

A : $\phi 9.52$ 3m
B : $\phi 9.52$ 2m
C : $\phi 15.88$ 2m

Total length for $\phi 15.88$ C=2m
each pipe size : $\phi 9.52$ A+B=5m
This yields the following result : =2x0.2+5x0.06+4.0
=4.7kg

⚠ Caution

Charge Liquid Refrigerant

Filling the equipment with gas refrigerant will result in a power loss due to transformation of refrigerant in the tank.

2. Designing of water circuit system

1) Example of basic water circuit

The water circuit of the water heat source CITY MULTI connects the heat source unit with the cooling tower/auxiliary heat source/heat storage tank/circulation pump with a single system water piping as shown in the figure below. The selector valve automatically controls to circulate water toward the cooling tower in the cooling season, while toward the heat storage tank in the heating season. If the circulation water temperature is kept in a range of 10~45°C[50~113°F]* regardless of the building load, the water heat source CITY MULTI can be operated for either cooling or heating. Therefore in the summer when only cooling load exists, the temperature rise of circulation water will be suppressed by operating the cooling tower. While in the winter when heating load increases, the temperature of circulation water may be dropped below 10°C[50°F]. Under such situation, the circulation water will be heated with the auxiliary heat source if it drops below a certain temperature.

When the thermal balance between cooling and heating operation is in a correct proportion, the operation of the auxiliary heat source and cooling tower is not required.

In order to control the above thermal balance properly and use thermal energy effectively, utilizing of heat storage tanks, and night-time discounted electric power as a auxiliary heat source will be economical.

Meantime as this system uses plural sets of heat source unit equipped with water heat exchangers, water quality control is important. Therefore it is recommended to use closed type cooling towers as much as possible to prevent the circulation water from being contaminated.

When open type cooling towers are used, it is essential to provide proper maintenance control such as that to install water treatment system to prevent troubles caused by contaminated circulation water.

Example of basic water circuit for water heat source CITY MULTI

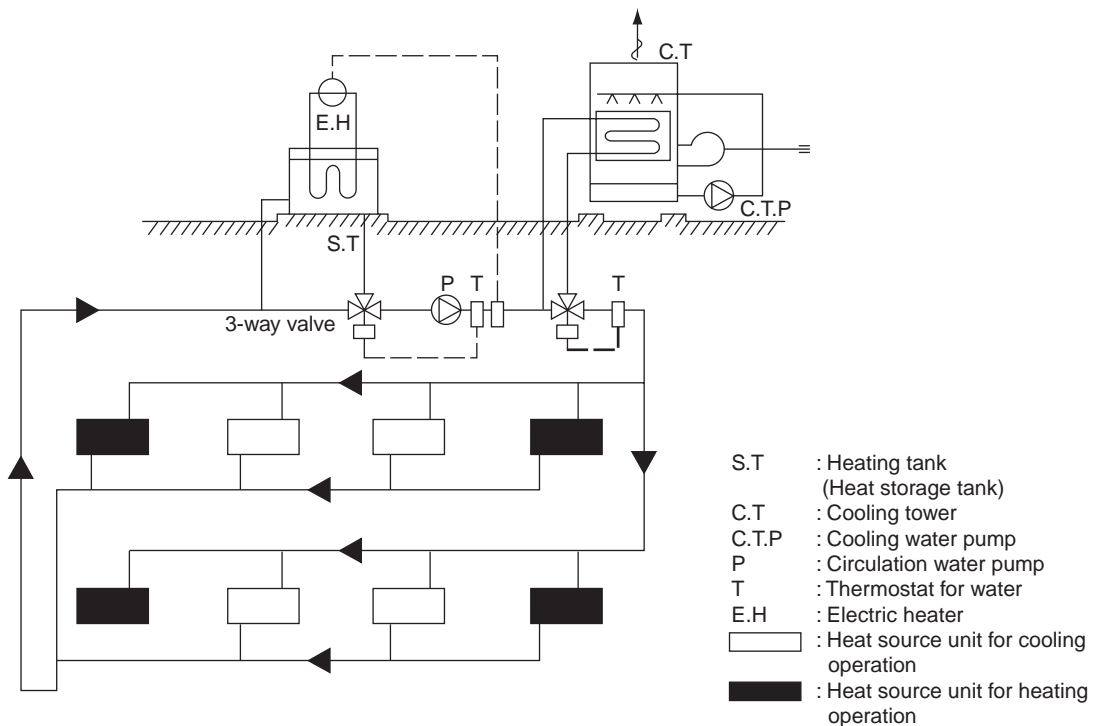

The indoor unit and refrigerant piping system are excluded in this figure.

2) Cooling tower

a) Types of cooling tower

The cooling towers presently used include the open type cooling tower, open type cooling tower + heat exchanger, closed type cooling tower, and air-cooled type cooling tower. However, as the quality control of circulation water is essential when units are installed in decentralized state inside a building, the closed type cooling tower is generally employed in such case.

Although the circulation water will not be contaminated by atmospheric air, it is recommended to periodically blow water inside the system and replenish fresh water instead.

In a district where the coil may be frozen in the winter, it is necessary to apply antifreeze solution to the circulation water, or take freeze protection measures such as to automatically discharge water inside the cooling coil at the stopping of the pump.

When the open type cooling tower is used, be sure to install a water quality control device in addition to the freeze protection measures, as the water may be deteriorated by atmospheric contaminants entered into the cooling tower and dissolved into the circulation water.

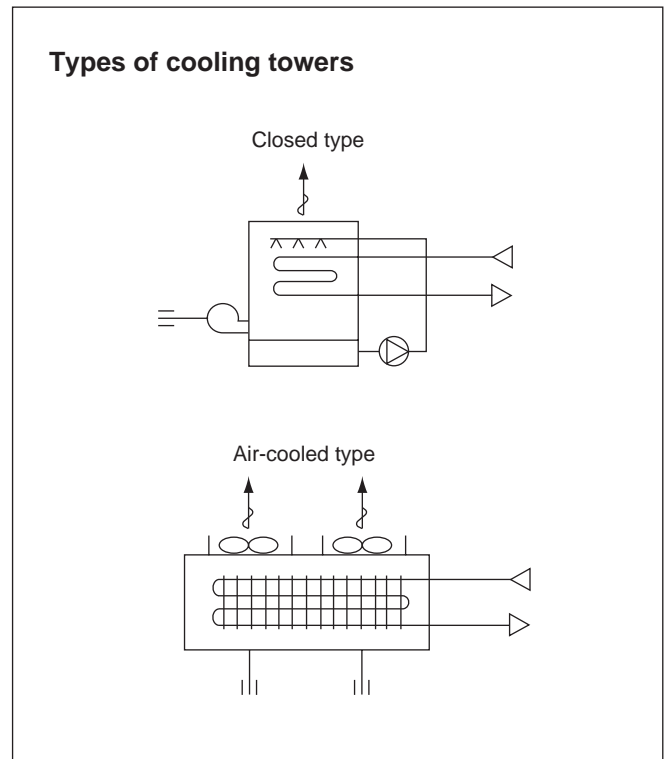

b) Calculation method of cooling tower capacity

All units of the water heat source CITY MULTI may possibly be in cooling operation temporarily (at pulling down) in the summer, however, it is not necessary to determine the capacity according to the total cooling capacity of all CITY MULTI units as this system has a wide operating water temperature range (10~45°C) [50~113°F].

It is determined in accordance with the value obtained by adding the maximum cooling load of an actual building, the input heat equivalent value of all CITY MULTI units, and the cooling load of the circulating pumps. Please check for the values of the cooling water volume and circulation water volume.

$$\text{Cooling tower capacity} = \frac{Q_c + 860 \times (\Sigma Q_w + P_w)}{3,900} \quad (\text{Refrigeration ton})$$

Q_c : Maximum cooling load under actual state (kcal/h)
 Q_w : Total input of water heat source CITY MULTI at simultaneous operation under maximum state (kW)
 P_w : Shaft power of circulation pumps (kW)

$$\text{Cooling tower capacity} = \frac{Q_c + 3,412 \times (\Sigma Q_w + P_w)}{15,500} \quad (\text{Refrigeration ton})$$

Q_c : Maximum cooling load under actual state (BTU/h)
 Q_w : Total input of water heat source CITY MULTI at simultaneous operation under maximum state (kW)
 P_w : Shaft power of circulation pumps (kW)

* 1 Refrigerant ton of cooling tower capacity \approx US refrigerant ton \times (1+0.3)
 $= 3,900 \text{ kcal/h} = 15,500 \text{ BTU/h}$

3) Auxiliary heat source and heat storage tank

When the heating load is larger than the cooling load, the circulation water temperature lowers in accordance with the heat balance of the system. It should be heated by the auxiliary heat source in order to keep the inlet water temperature within the operating range (10°C[50°F] or more) of the water heat source CITY MULTI.

Further in order to operate the water heat source CITY MULTI effectively, it is recommended to utilize the heat storage tank to cover the warming up load in the morning and the insufficient heat amount.

Effective heat utilization can be expected to cover insufficient heat at the warming up in the next morning or peak load time by storing heat by installing a heat storage tank or operating a low load auxiliary heat source at the stopping of the water heat source CITY MULTI. As it can also be possible to reduce the running cost through the heat storage by using the discounted night-time electric power, using both auxiliary heat source and heat storage tank together is recommended.

The effective temperature difference of an ordinary heat storage tank shows about 5deg. even with the storing temperature at 45°C[113°F].

However with the water heat source CITY MULTI, it can be utilized as heating heat source up to 15°C[59°F] with an effective temperature of a high 30deg°C[54deg°F]. approximately, thus the capacity of the heat storage tank can be minimized.

a) Auxiliary heat source

The following can be used as the auxiliary heat source.

- Boiler (Heavy oil, kerosine, gas, electricity)
- Electric heat (Insertion of electric heater into heat storage tank)
- Outdoor air (Air-heat source heat pump chiller)
- Warm discharge water (Exhaust water heat from machines inside building and hot water supply)
- Utilization of night-time lighting
- Solar heat

Please note that the auxiliary heat source should be selected after studying your operating environment and economical feasibility.

Determining the auxiliary heat source capacity

For the CITY MULTI water heat source system, a heat storage tank is recommended to use. When employment of the heat storage tank is difficult, the warming up operation should be arranged to cover the starting up heating load. Since the holding water inside the piping circuit owns heat capacity and the warming up operation can be assumed for about one hour except that in a cold region, the heat storage tank capacity is required to be that at the maximum daily heating load including the warming up load at the next morning of the holiday. However the auxiliary heat source capacity should be determined by the daily heating load including warming up load on the week day.

For the load at the next morning of the holiday, heat storage is required by operating the auxiliary heat source even outside of the ordinary working hour.

When heat storage tank is not used

$$QH = HC_T \left(1 - \frac{1}{COP_h} \right) - 1000 \times V_w \times \Delta T - 860 \times P_w$$

QH	: Auxiliary heat source capacity	(kcal/h)
HC _T	: Total heating capacity of each water heat source CITY MULTI	(kcal/h)
COP _H	: COP of water heat source CITY MULTI at heating	
V _w	: Holding water volume inside piping	(m ³)
ΔT	: Allowable water temperature drop = T _{WH} - T _{WL}	(°C)
T _{WH}	: Heat source water temperature at high temperature side	(°C)
T _{WL}	: Heat source water temperature at low temperature side	(°C)
P _w	: Heat source water pump shaft power	(kW)

$$QH = HC_T \left(1 - \frac{1}{COP_h} \right) - 8.343 \times V_w \times \Delta T - 3412 \times P_w$$

QH	: Auxiliary heat source capacity	(BTU/h)
HC _T	: Total heating capacity of each water heat source CITY MULTI	(BTU/h)
COP _H	: COP of water heat source CITY MULTI at heating	
V _w	: Holding water volume inside piping	(G)
ΔT	: Allowable water temperature drop = T _{WH} - T _{WL}	(°F)
T _{WH}	: Heat source water temperature at high temperature side	(°F)
T _{WL}	: Heat source water temperature at low temperature side	(°F)
P _w	: Heat source water pump shaft power	(kW)

When heat storage tank is not used

$$QH = \frac{HQ_{1T} \cdot \left(1 - \frac{1}{COP_h} \right) - 860 \times P_w \times T_2}{T_1} \times K \quad (\text{kcal})$$

- QH_{1T} : Total of heating load on weekday including warming up (kcal/day)
 T₁ : Operating hour of auxiliary heat source (h)
 T₂ : Operating hour of heat source water pump (h)
 K : Allowance factor (Heat storage tank, piping loss, etc.) 1.05~1.10

HQ_{1T} is calculated from the result of steady state load calculation similarly by using the equation below.
 $HQ_{1T} = 1.15 \times (\Sigma Q'a + \Sigma Q'b + \Sigma Q'c + \Sigma Q'd + \Sigma Q'f) T_2 - \Psi (\Sigma Qe_1 + \Sigma Qe_2 + \Sigma Qe_3) (T_2 - 1)$

- Q'a : Thermal load from external wall/roof in each zone (kcal/h)
 Q'b : Thermal load from glass window in each zone (kcal/h)
 Q'c : Thermal load from partition/ceiling/floor in each zone (kcal/h)
 Q'd : Thermal load by infiltration in each zone (kcal/h)
 Q'f : Fresh outdoor air load in each zone (kcal/h)
 Q'e₁ : Thermal load from human body in each zone (kcal/h)
 Q'e₂ : Thermal load from lighting fixture in each zone (kcal/h)
 Q'e₃ : Thermal load from equipment in each zone (kcal/h)
 Ψ : Radiation load rate 0.6~0.8
 T₂ : Air conditioning hour

$$QH = \frac{HQ_{1T} \cdot \left(1 - \frac{1}{COP_h} \right) - 3,412 \times P_w \times T_2}{T_1} \times K \quad (\text{BTU})$$

- QH_{1T} : Total of heating load on weekday including warming up (BTU/day)
 T₁ : Operating hour of auxiliary heat source (h)
 T₂ : Operating hour of heat source water pump (h)
 K : Allowance factor (Heat storage tank, piping loss, etc.) 1.05~1.10

HQ_{1T} is calculated from the result of steady state load calculation similarly by using the equation below.
 $HQ_{1T} = 1.15 \times (\Sigma Q'a + \Sigma Q'b + \Sigma Q'c + \Sigma Q'd + \Sigma Q'f) T_2 - \Psi (\Sigma Qe_1 + \Sigma Qe_2 + \Sigma Qe_3) (T_2 - 1)$

- Q'a : Thermal load from external wall/roof in each zone (BTU/h)
 Q'b : Thermal load from glass window in each zone (BTU/h)
 Q'c : Thermal load from partition/ceiling/floor in each zone (BTU/h)
 Q'd : Thermal load by infiltration in each zone (BTU/h)
 Q'f : Fresh outdoor air load in each zone (BTU/h)
 Q'e₁ : Thermal load from human body in each zone (BTU/h)
 Q'e₂ : Thermal load from lighting fixture in each zone (BTU/h)
 Q'e₃ : Thermal load from equipment in each zone (BTU/h)
 Ψ : Radiation load rate 0.6~0.8
 T₂ : Air conditioning hour

b) Heat storage tank

Heat storage tank can be classified by types into the open type heat storage tank exposed to atmosphere, and the closed type heat storage tank with structure separated from atmosphere. Although the size of the tank and its installation place should be taken into account, the closed type tank is being usually employed by considering corrosion problems. The capacity of heat storage tanks is determined in accordance with the daily maximum heating load that includes warming up load to be applied for the day after the holiday.

When auxiliary heat source is operated during operation and even after stopping of water heat source CITY MULTI unit

$$V = \frac{HQ_{2T} \left(1 - \frac{1}{COP_h} \right) - 860 \times P_w \times T_2 - Q_H \times T_2}{\Delta T \times 1,000 \times \eta V} \quad (\text{ton})$$

HQ_{2T} : Maximum heating load including load required for the day after the holiday (kcal/day)
 ΔT : Temperature difference utilized by heat storage tank (deg°C)
 ηV : Heat storage tank efficiency

$$HQ_{2T} : 1.3 \times (\Sigma Q'a + \Sigma Q'c + \Sigma Q'd + \Sigma Q'f) T_2 - \psi(\Sigma Qe2 + \Sigma Qe3) (T_2 - 1)$$

$$V = \frac{HQ_{2T} \left(1 - \frac{1}{COP_h} \right) - 3,412 \times P_w \times T_2 - Q_H \times T_2}{\Delta T \times \eta V} \quad (\text{lbs})$$

HQ_{2T} : Maximum heating load including load required for the day after the holiday (BTU/day)
 ΔT : Temperature difference utilized by heat storage tank (deg°F)
 ηV : Heat storage tank efficiency

$$HQ_{2T} : 1.3 \times (\Sigma Q'a + \Sigma Q'c + \Sigma Q'd + \Sigma Q'f) T_2 - \psi(\Sigma Qe2 + \Sigma Qe3) (T_2 - 1)$$

When auxiliary heat source is operated after stopping of water heat source CITY MULTI unit

$$V = \frac{HQ_{2T} \left(1 - \frac{1}{COP_h} \right) - 860 \times P_w \times T_2}{\Delta T \times 1,000 \times \eta V} \quad (\text{ton})$$

HQ_{2T} : Maximum heating load including load required for the day after the holiday (kcal/day)
 ΔT : Temperature difference utilized by heat storage tank (deg°C)
 ηV : Heat storage tank efficiency

$$HQ_{2T} : 1.3 \times (\Sigma Q'a + \Sigma Q'c + \Sigma Q'd + \Sigma Q'f) T_2 - \psi(\Sigma Qe2 + \Sigma Qe3) (T_2 - 1)$$

$$V = \frac{HQ_{2T} \left(1 - \frac{1}{COP_h} \right) - 3,412 \times P_w \times T_2}{\Delta T \times \eta V} \quad (\text{lbs})$$

HQ_{2T} : Maximum heating load including load required for the day after the holiday (BTU/day)
 ΔT : Temperature difference utilized by heat storage tank (deg°F)
 ηV : Heat storage tank efficiency

$$HQ_{2T} : 1.3 \times (\Sigma Q'a + \Sigma Q'c + \Sigma Q'd + \Sigma Q'f) T_2 - \psi(\Sigma Qe2 + \Sigma Qe3) (T_2 - 1)$$

4) Piping system

The following items should be kept in your mind in planning / designing water circuits.

- All units should be constituted in a single circuit in principle.
- When plural numbers of the water heat source CITY MULTI unit are installed, the rated circulating water flow rate should be kept by making the piping resistance to each unit almost same value. As an example, the reverse return system as shown below may be employed.
- Depending on the structure of a building, the water circuit may be prefabricated by making the layout uniform.
- When a closed type piping circuit is constructed, install an expansion tank usable commonly for a make-up water tank to absorb the expansion/contraction of water caused by temperature fluctuation.
- If the operating temperature range of circulation water stays within the temperature near the normal temperature (summer : 29.4°C[85°F], winter : 21.1°C[70°F]), thermal insulation or anti-sweating work is not required for the piping inside buildings.

In case of the conditions below, however, thermal insulation is required.

- When well water is used for heat source water.
- When piped to outdoor or a place where freezing may be caused.
- When vapor condensation may be generated on piping due to an increase in dry bulb temperature caused by the entry of fresh outdoor air.

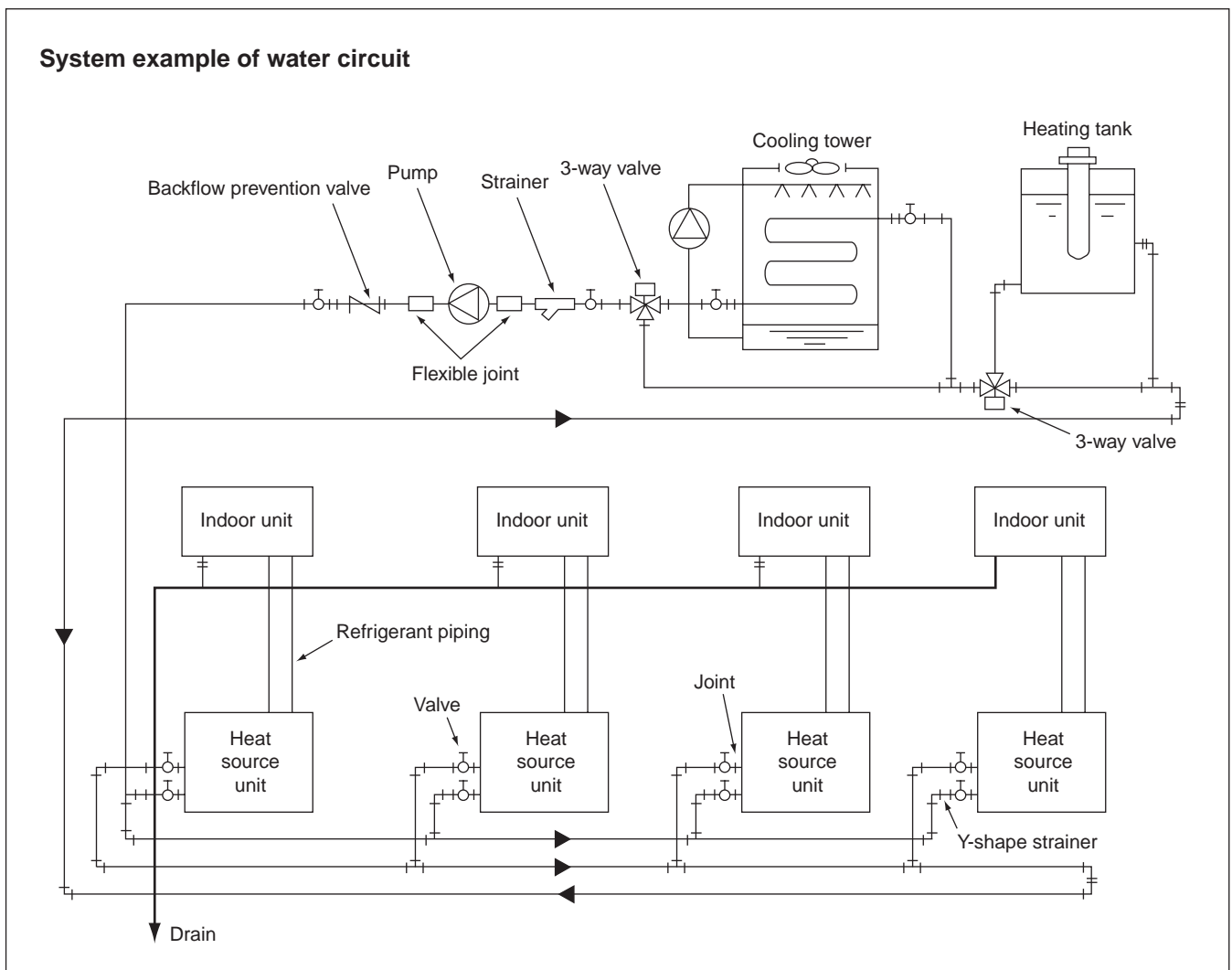

5) Practical System Examples and Circulation Water Control

Since the water heat source CITY MULTI is of water heat source system, versatile systems can be constituted by combining it with various heat sources.

The practical system examples are given below.

Either cooling or heating operation can be performed if the circulation water temperature of the water heat source CITY MULTI stays within a range of 10~45°C [50~113°F]. However, the circulation water temperature near 32°C[90°F] for cooling and 20°C[68°F] for heating is recommended by taking the life, power consumption and capacity of the air conditioning units into consideration. The detail of the control is also shown below.

Example-1 Combination of closed type cooling tower and hot water heat storage tank (using underground hollow slab)

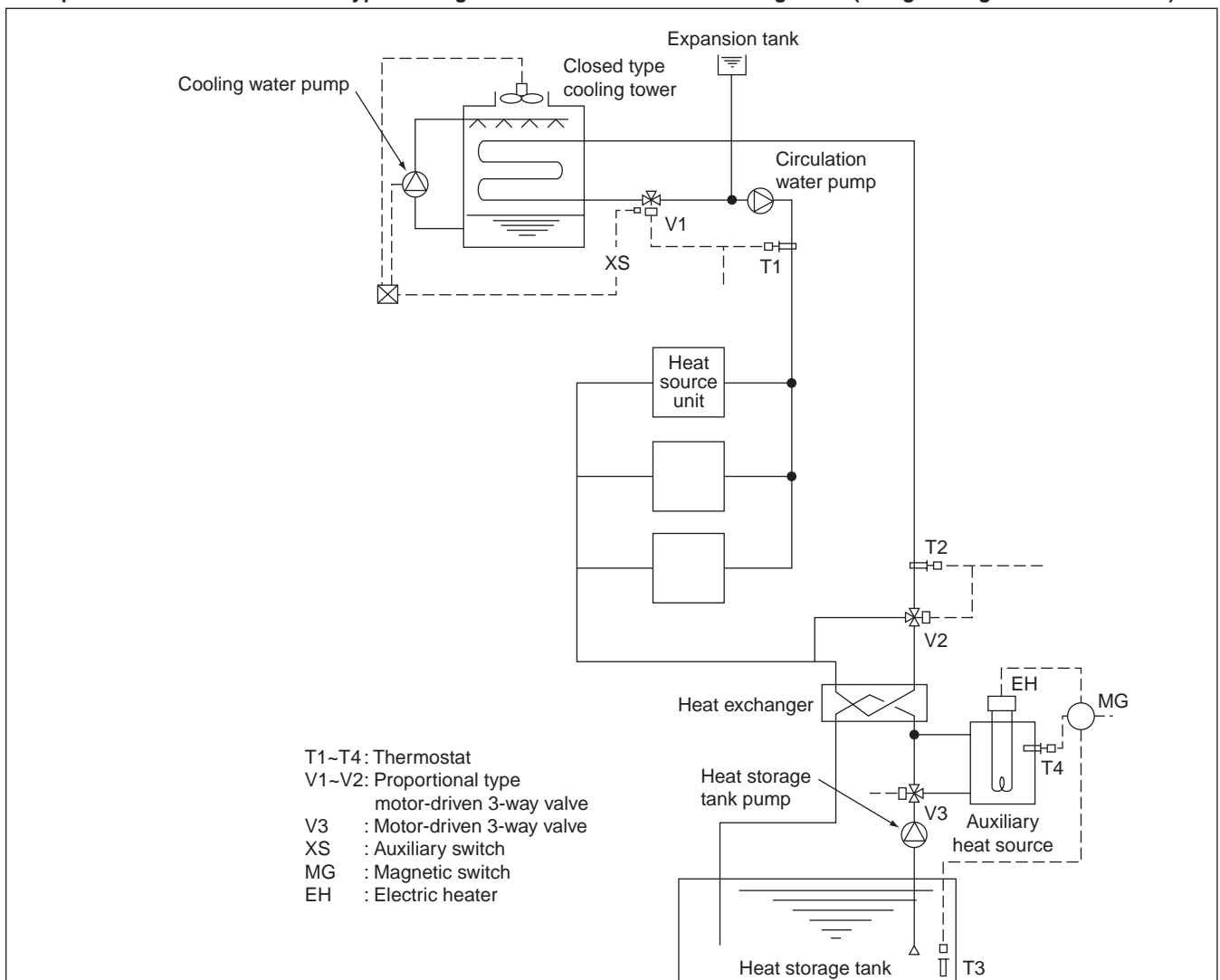

By detecting the circulation water temperature of the water heat source CITY MULTI system with T1 (around 32°C[90°F]) and T2 (around 20°C[68°F]), the temperature will be controlled by opening/closing V1 in the summer and V2 in the winter.

In the summer, as the circulation water temperature rises exceeding the set temperature of T1, the bypass port of V1 will open to lower the circulation water temperature. While in the winter, as the circulation water temperature drops, V2 will open following the command of T2 to rise the circulation water temperature.

The water inside the heat storage tank will be heated by the auxiliary heat source by V3 being opened with timer operation in the night-time. The electric heater of the auxiliary heat source will be controlled by T3 and the timer. The start/stop control of the fan and pump of the closed type cooling tower is applied with the step control of the fan and pump following the command of the auxiliary switch XS of V1, that operates only the fan at the light load while the fan and pump at the maximum load thus controlling water temperature and saving motor power.

Example-2 Combination of closed type cooling tower and hot water heat storage tank

- T1 : Proportional type, insertion system thermostat
- T2 : Proportional type, insertion system thermostat
- T3 : Proportional type, insertion system thermostat
- V1 : Proportional type, motor-driven 3-way valve
- V2 : Proportional type, motor-driven 3-way valve
- XS : Auxiliary switch (Duplex switch type)
- SC : Step controller
- R : Relay
- MG : Magnetic

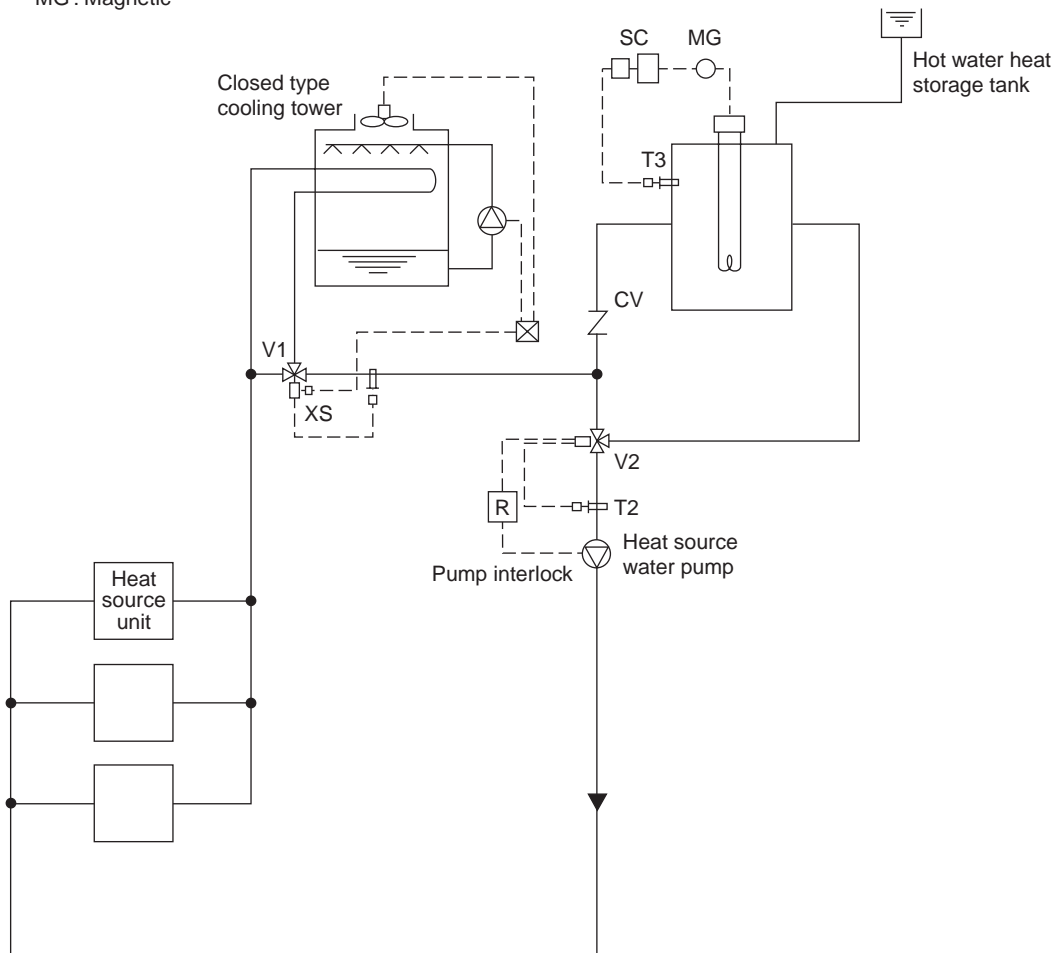

In the summer, as the circulation water temperature rises exceeding the set temperature of T1, the bypass port of V1 will open to lower the circulation water temperature. In the winter, if the circulation water temperature stays below 25°C[77°F], V2 will open/close by the command of T2 to keep the circulation water temperature constant. The temperature of the hot water inside the heat storage tank will be controlled through the step control of the electric heater by step controller operation following the command of T3. During the stopping of the heat source water pump, the bypass port of V2 will be closed fully by interlocking thus preventing the high temperature water from entering into the system at the starting of the pump. The start/stop control of the fan and pump of the closed type cooling tower is applied with the step control of the fan and pump following the command of the auxiliary switch XS of V1, that operates only the fan at the light load while the fan and pump at the maximum load thus controlling water temperature and saving motor power.

Example-3 Combination of closed type cooling tower and boiler

- T1 : Proportional type, insertion system thermostat
- T2 : Proportional type, insertion system thermostat
- T3 : Proportional type, insertion system thermostat
- V1 : Proportional type, motor-driven 3-way valve
- S : Selector switch
- R : Relay
- XS : Auxiliary switch (Duplex switch type)

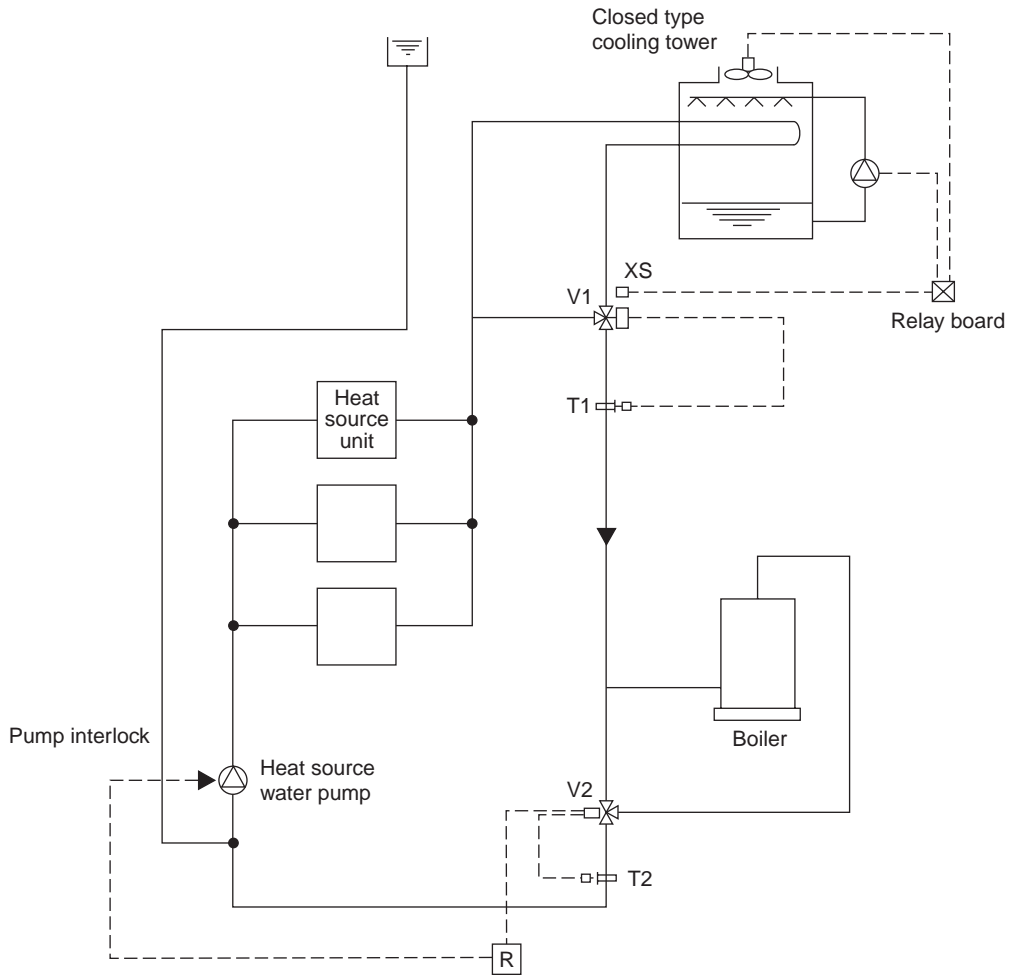

In the summer, as the circulation water temperature rises exceeding the set temperature of T1, the bypass port of V1 will close to lower the circulation water temperature. In the winter, if the circulation water temperature drops below 25°C[77°F], V2 will conduct water temperature control to keep the circulation water temperature constant. During the stopping of the heat source water pump, the bypass port of V2 will be closed fully by interlocking. The start/stop control of the fan and pump of the closed type cooling tower is applied with the step control following the command of the auxiliary switch XS of V1, thus controlling water temperature and saving motor power.

Example-4 Combination of closed type cooling tower and heat exchanger (of other heat source)

- T1 : Proportional type, insertion system thermostat
- T2 : Proportional type, insertion system thermostat
- V1 : Proportional type, motor-driven 3-way valve
- V2 : Proportional type, motor-driven 3-way valve
- S : Selector switch
- R : Relay
- XS : Auxiliary switch (Duplex switch type)

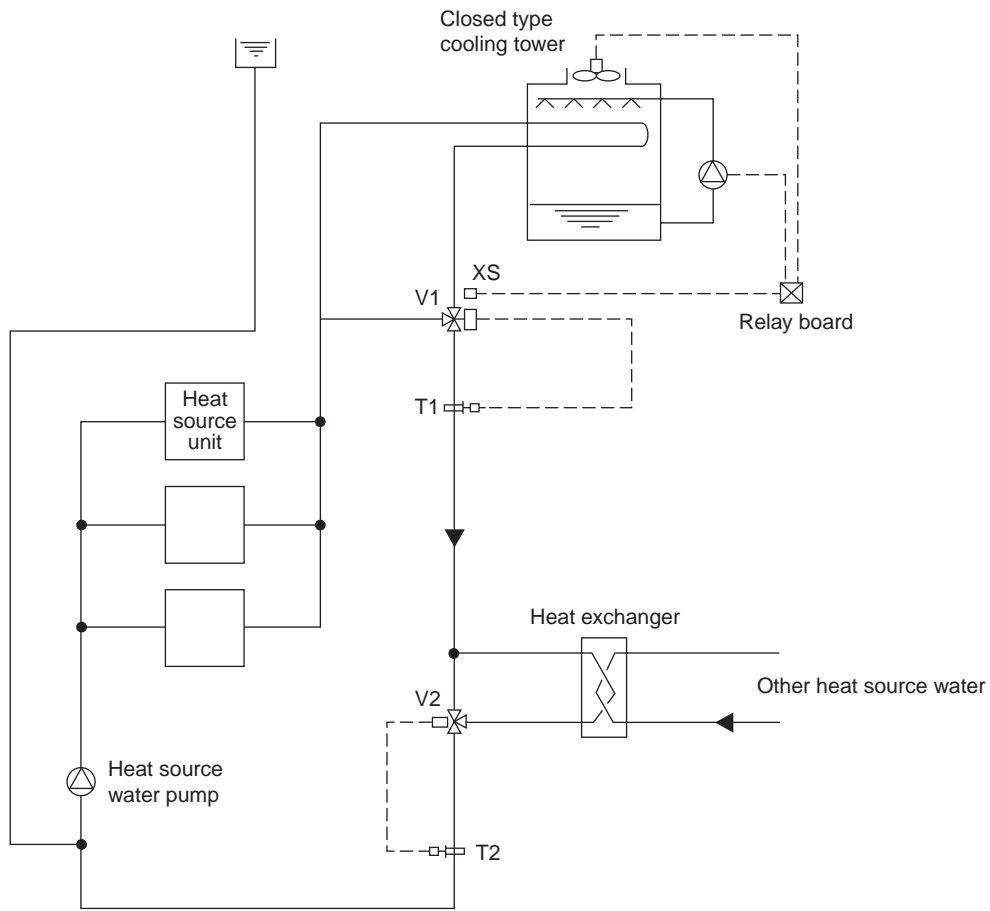

In the summer, as the circulation water temperature rises exceeding the set temperature of T1, the bypass port of V1 will close to lower the circulation water temperature. In the winter, if the circulation water temperature drops below 26°C[79°F], V2 will conduct water temperature control to keep the circulation water temperature constant. During the stopping of the heat source water pump, the bypass port of V2 will be closed fully by interlocking. The start/stop control of the fan and pump of the closed type cooling tower is applied with the step control following the command of the auxiliary switch XS of V1, thus controlling water temperature and saving motor power.

6) Pump interlock circuit

Operating the heat source unit without circulation water inside the water piping can cause a trouble.
 Be sure to provide interlocking for the unit operation and water circuit.
 Since the terminal block is being provided inside the unit, use it as required.

Wiring diagram

This circuit uses the Terminal block for pump interlock (TB8) inside the electrical parts box of the heat source equipment.
 This circuit is for interlocking of the heat source equipment operation and the heat source water pump.

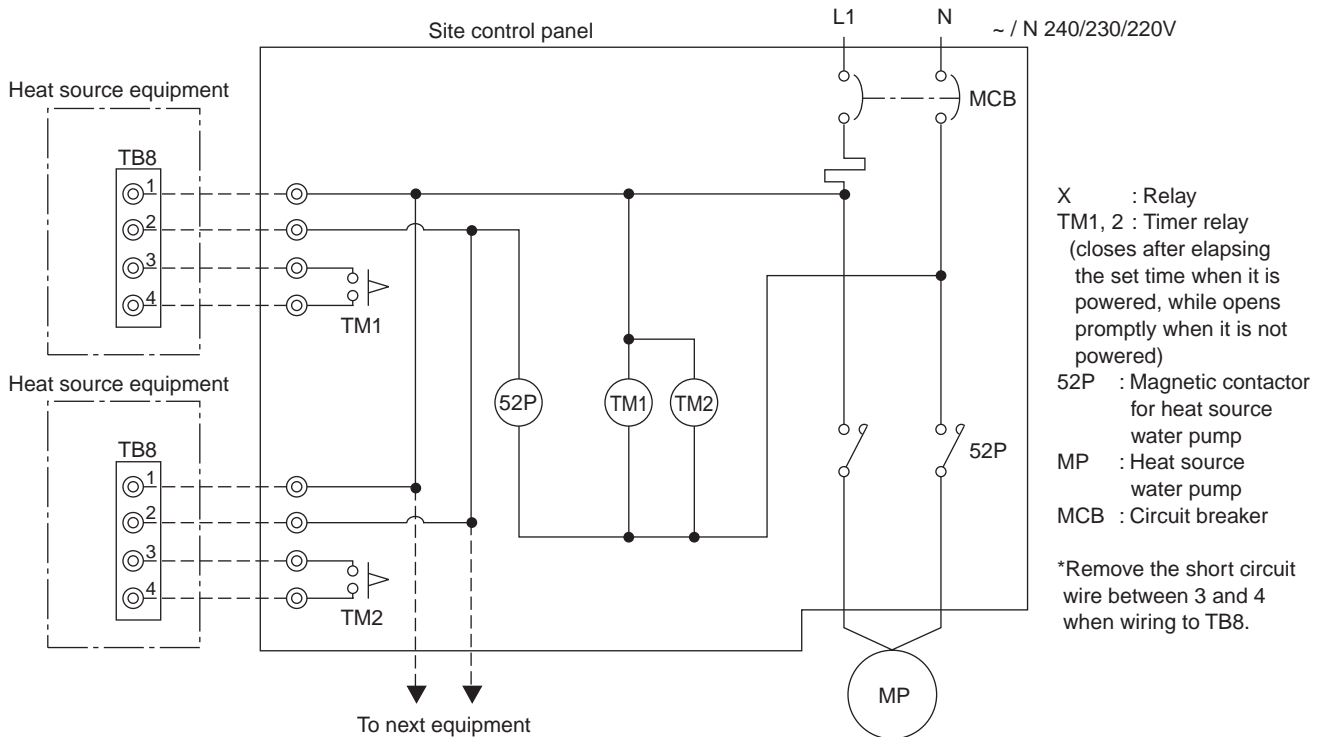

Operation ON signal

Terminal No.	TB8-1, 2
Output	Relay contacts output Rated voltage : L1 - N : 220 ~ 240V Rated load : 1A
Operation	<ul style="list-style-type: none">• When Dip switch 2-7 is OFF The relay closes during compressor operation.• When DIP switch 2-7 is ON. The relay closes during reception of cooling or the heating operation signal from the controller. (Note : It is output even if the thermostat is OFF (when the compressor is stopped).)

Pump Interlock

Terminal No.	TB8-3, 4
Input	Level signal
Operation	If the circuit between TB8-3 and TB8-4 is open, compressor operation is prohibited.

3. Water piping work

Although the water piping for the CITY MULTI WY system does not differ from that for ordinary air conditioning systems, pay special attention to the items below in conducting the piping work.

1) Items to be observed on installation work

- In order to equalize piping resistance for each unit, adapt the reverse return system.
- Mount a joint and a valve onto the water outlet/inlet of the unit to allow for maintenance, inspection and replacement work. Be sure to mount a strainer at the water inlet piping of the unit. (The strainer is required at the circulation water inlet to protect the heat source unit.)
- * The installation example of the heat source unit is shown right.
- Be sure to provide an air relief opening on the water piping properly, and purge air after feeding water to the piping system.
- Condensate will generate at the low temperature part inside the heat source equipment. Connect drain piping to the drain piping connection located at the bottom of the heat source equipment to discharge it outside the equipment.
- At the center of the header of the heat exchanger water inlet inside the unit, a plug for water discharge is being provided. Use it for maintenance work or the like.
- Mount a backflow prevention valve and a flexible joint for vibration control onto the pump.
- Provide a sleeve to the penetrating parts of the wall to prevent the piping.
- Fasten the piping with metal fitting, arrange the piping not to expose to cutting or bending force, and pay sufficient care for possible vibration.
- Be careful not to erroneously judge the position of the inlet and outlet of water.
(Lower position : Inlet, Upper position : Outlet)

2) Thermal insulation work

Thermal insulation or anti sweating work is not required for the piping inside buildings in the case of the CITY MULTI WY system if the operating temperature range of circulation water stays within the temperature near the normal (summer : 29.4°C[85°F], winter : 21.1°C[70°F]).

In case of the conditions below, however, thermal insulation is required.

- Use of well water for heat source water
- Outdoor piping portions
- Indoor piping portions where freezing may be caused in winter
- A place where vapor condensation may be generated on piping due to an increase in dry bulb temperature inside the ceiling caused by the entry of fresh outdoor air
- Drain piping portions

3) Water treatment and water quality control

For the circulation water cooling tower of the CITY MULTI WY system, employment of the closed type is recommended to keep water quality. However, in the case that an open type cooling tower is employed or the circulating water quality is inferior, scale will adhere onto the water heat exchanger leading to the decreased heat exchange capacity or the corrosion of the heat exchanger. Be sufficiently careful for water quality control and water treatment at the installation of the circulation water system.

- Removal of impurities inside piping
Be careful not to allow impurities such as welding fragment, remaining sealing material and rust from mixing into the piping during installation work.

• Water treatment

The water quality standards have been established by the industry (Japan Refrigeration, Air Conditioning Industry Association, in case of Japan) for water treatment to be applied.

In order to keep the water quality within such standards, you are kindly requested to conduct bleeding-off by overflow and periodical water quality tests, and use inhibitors to suppress condensation or corrosion. Since piping may be corroded by some kinds of inhibitor, consult an appropriate water treatment expert for proper water treatment.

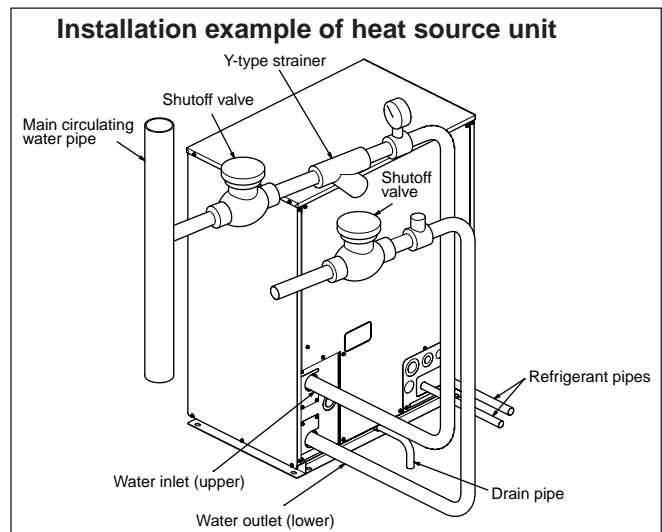

Items	Lower mid-range temperature water system		Tendency	
	Recirculating water [20<T<60°C] [68<T<140°F]	Make-up water	Corrosive	Scale-forming
pH (25°C[77°F])	7.0 ~ 8.0	7.0 ~ 8.0	○	○
Electric conductivity (mS/m) (25°C[77°F])	30 or less	30 or less	○	○
(μS/cm) (25°C[77°F])	[300 or less]	[300 or less]	○	○
Chloride ion (mg Cl/l)	50 or less	50 or less	○	
Sulfate ion (mg SO ₄ ²⁻ /l)	50 or less	50 or less	○	
Acid consumption (pH4.8) (mg CaCO ₃ /l)	50 or less	50 or less		○
Total hardness (mg CaCO ₃ /l)	70 or less	70 or less		○
Calcium hardness (mg CaCO ₃ /l)	50 or less	50 or less		○
Ionic silica (mg SiO ₂ /l)	30 or less	30 or less		○
Iron (mg Fe/l)	1.0 or less	0.3 or less	○	○
Copper (mg Cu/l)	1.0 or less	0.1 or less	○	
Sulfide ion (mg S ²⁻ /l)	not to be detected	not to be detected	○	
Ammonium ion (mg NH ₄ ⁺ /l)	0.3 or less	0.1 or less	○	
Residual chlorine (mg Cl/l)	0.25 or less	0.3 or less	○	
Free carbon dioxide (mg CO ₂ /l)	0.4 or less	4.0 or less	○	
Ryzner stability index	-	-	○	○

Reference : Guideline of Water Quality for Refrigeration and Air Conditioning Equipment. (JRA GL02E-1994)

4.Control Wiring

Restrictions when the PFD-type indoor units are connected (related to the system)

- (1) The PFD-type indoor units cannot be connected to the ME remote controller.
- (2) The address settings must be made on this system.
- (3) The following functions cannot be selected on the PFD-type indoor units.
 - 1) Switching between automatic power recovery Enabled/Disabled (Fixed to "Enabled" in the PFD-type indoor units)
 - 2) Switching between power source start/stop (Fixed to "Disabled" in the PFD-type indoor units)
- (4) The PFD-type indoor units and other types of indoor units cannot be grouped.
- (5) The following functions are limited when the system controller (such as G-50A) is connected.
 - 1) To perform group operation in the system with two refrigerant circuits (combination of two outdoor units and one indoor unit: P500 model only), the addresses of the controller boards No.1 and No.2 on a indoor unit must be set within a group.
 - 2) The local operation cannot be prohibited with the system controller.
 - 3) When the switches of the PFD-type indoor units are set as follows, the unit ON/OFF operation cannot be made with the system controller.
 - When the Normal/Local switching switch is set to "Local"
 - When the DipSW1-10 on the control circuit board is set to "ON"
 - 4) The PFD type indoor units cannot be grouped with other types of indoor units.

(1) Specifications of control wiring and maximum length of wiring

Transmission line is a type of control line. When the source of noise is located adjacent to the unit, the use of shield cable as well as moving the unit as far away from the noise source are recommended.

① Transmission line (M-NET transmission line)

System component		For multiple-refrigerant system
Wiring specifications	Length of transmission line	n/a
	Facility type (noise level measurement)	All types of facilities
	Cable type	Shield cable CVVS · CPEVS · MVVS
	No. of cable	2-core cable
	Diameter	Over 1.25mm ²
Total length of indoor/outdoor transmission line		Maximum length: 200m Maximum length of centralized control transmission line and Indoor/Outdoor transmission line via indoor/outdoor units: 500m maximum

② Remote control wiring

		MA remote controller ※ 1
Wiring specifications	Cable type	VCTF · VCTFK · CVV · CVS · VVR · VVF · VCT
	No. of cable	2-core cable
	Diameter	0.3~1.25mm ² ※ 2 (0.75~1.25mm ²) ※ 3
Total Length		Maximum length: 200 m

※ 1: "MA remote controller" includes MA remote controller, Simple MA controller, and wireless remote controller.

※ 2: Cables with a diameter of 0.75mm² or smaller recommended for easier handling.

※ 3: When connecting to Simple MA controller terminal, use a cable with a diameter within the range shown in the parenthesis.

5.Types of switch settings and setting methods

Whether a particular system requires switch settings depends on its components. Refer to the section "7-4 Sample System Connection" before conducting electrical work.

Keep the power turned off while setting the switches. If settings are changed while being powered, the changed settings will not register, and the unit may malfunction.

Unit		Symbol	Turn off the power to
Outdoor unit		OC	Outdoor unit
Indoor unit	Main/sub controllers ※	IC	Indoor and outdoor units

※ 10HP has only the main controller

(1) Address setting

The need for address settings and the range of address setting depend on the configuration of the system. Refer to "Sample System Connection".

Unit or controller		Symbol	Address setting range	Address setting method	Factory setting Model
Indoor unit	Main · Sub	IC	01~50 (Note 1)	In case of 10HP system or 20HP system with one refrigerant circuit, assign an odd number starting with "01". In case of 20HP system with two refrigerant circuits, assign a sequential odd number starting with "01" to the upper indoor controller, and assign "the address of the upper indoor controller + 1" to the lower indoor controller. (For the system with one refrigerant circuit, the lower circuit board is not used.)	00
MA remote controller		MA	No address setting required.	(The main/sub switch must be configured if two remote controllers are connected to the system or if the indoor units are connected to different outdoor units.)	Main
Outdoor unit Heat source unit		OC OS	51~100 (Note 2)	In the system that consists of single refrigerant circuit, assign an address that equals the lowest indoor unit (main) address in the same refrigerant circuit plus 50. Assign sequential addresses to the outdoor units in the same refrigerant circuit. Set the OC address to odd number address and OS address to even number address on the computer room outdoor unit. In the system that consists of two refrigerant circuits, assign an address that equals the connected indoor unit control board address plus 50.	00

(Note1) If a given address overlaps any of the addresses that are assigned to other outdoor units, use a different, unused address within the setting range.

(Note2) To set the address of an outdoor unit to "100", set it as 50.

(2) Power supply switch connector connection on the outdoor unit

(Factory setting: The male power supply switch connector is connected to CN41.)

System configuration	Connection to the system controller	Power supply unit for transmission lines	Grouping the indoor units connected to different outdoor units	Power supply switch connector connection
System in which indoor units connected to one outdoor unit	—	—	—	Leave the male connector on CN41 as it is. (Factory setting)
System in which indoor units connected to multiple outdoor units	Not connected	—	Not grouped	Disconnect the male connector from the female power supply switch connector (CN41) and connect it to the female power supply switch connector (CN40) on only one of the outdoor units (OC). *Connect the S (shielded) terminal on the terminal block (TB7) on the outdoor unit whose male connector on CN41 was disconnected and connected to CN40 to the earth terminal () on the control box.
			Grouped	
	With connection to indoor-outdoor transmission line	Not required	Grouped /Not grouped	
			Grouped /Not grouped	
With connection to transmission line for centralized control	Not required (Powered from the outdoor unit)	Grouped /Not grouped	Leave the male connector on CN41 as it is. (Factory setting)	
		Required		

※ When the system controller is connected to the indoor/outdoor transmission line and the power is supplied from the outdoor unit, do not to turn off the outdoor unit. If its power supply is cut, the power is not supplied to the system controller, and the functions will not work.

※ In the system that consists of two refrigerant circuits, move the power jumper from (CN41) to (CN40) on only one of the outdoor units even when the system controller is not connected.

(3) Choosing the temperature detection spot by indoor unit (Factory Setting: SWC “Standard”)

When using the suction temperature sensor, set SWC to “Option.”

(The discharge temperature sensor is supplied as standard specification.)

(4) Setting the MA “Sub” controller

When using two remote controllers or running two indoor units as a group, one of the controllers must be set to “Sub” controller.

※ No more than two remote controllers can be connected to a group.

(Factory setting: “Main”)

Set the controller according to the following procedure. Refer also to the instructions manual supplied with the MA remote controller.

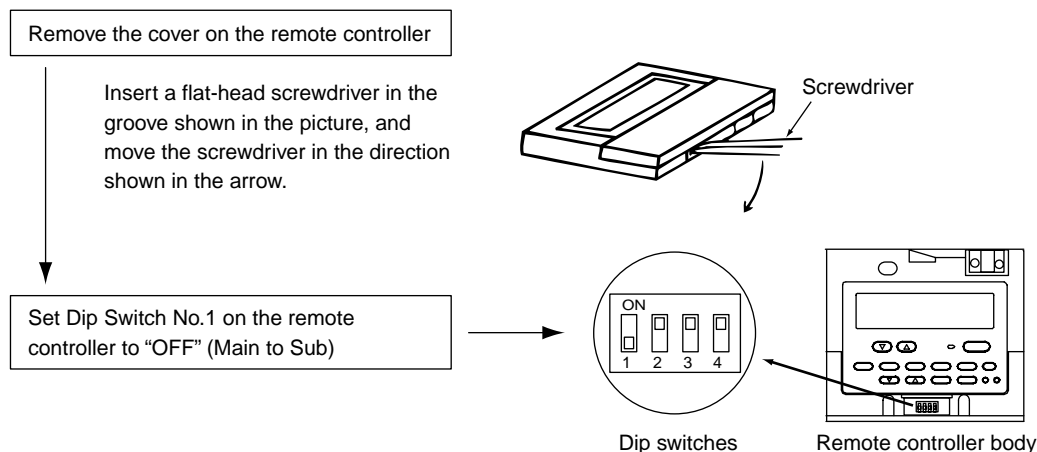

(5) Connection of two refrigerant circuits

When two refrigerant circuits are connected on site, make the switch settings on the controller circuit board following the instructions described in the installation manual for the indoor unit.

6. Sample System Connection

(1) System with MA remote controller

① System connected to one outdoor unit

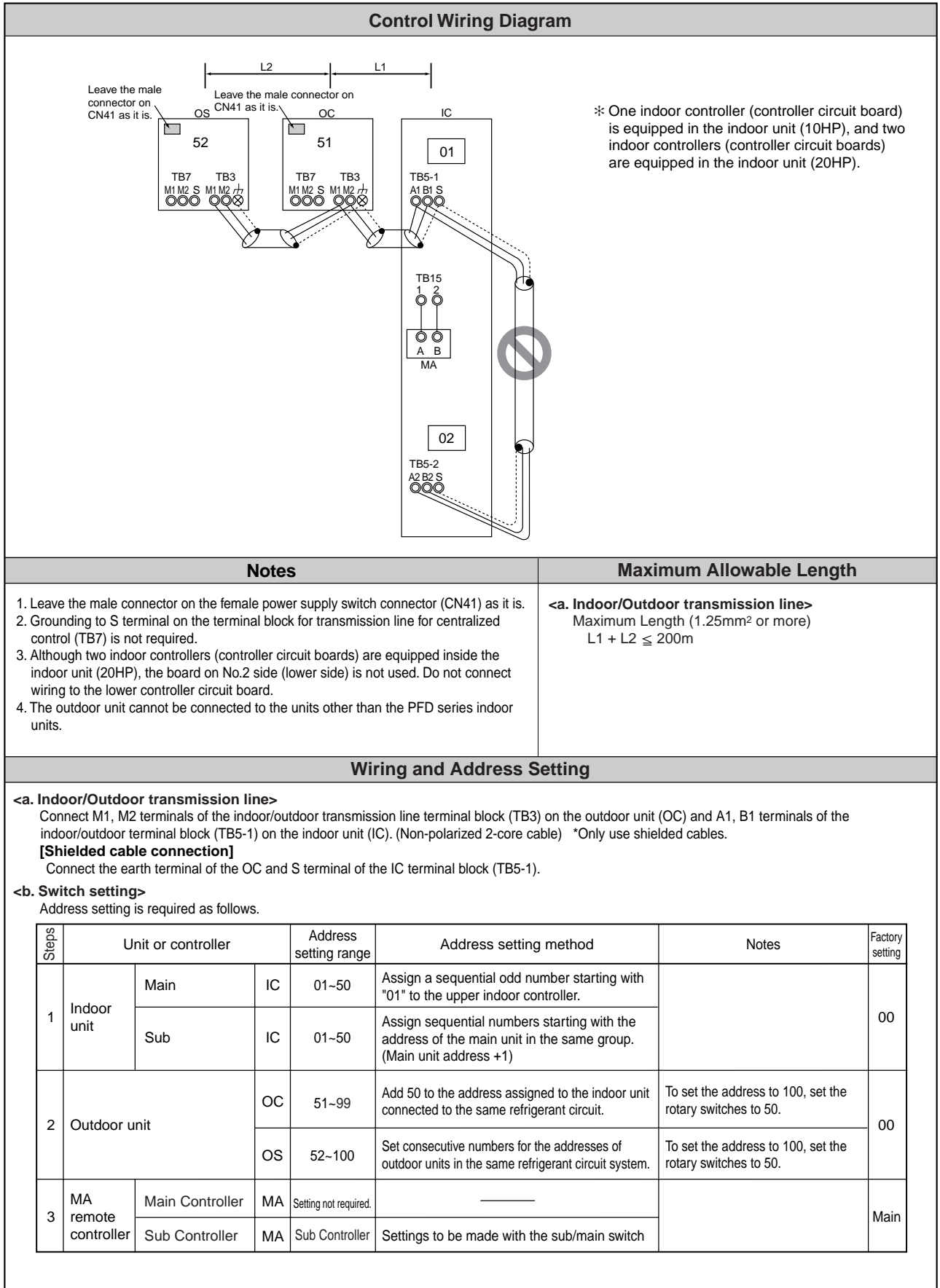

(1) System with MA remote controller

② System connected to two outdoor units

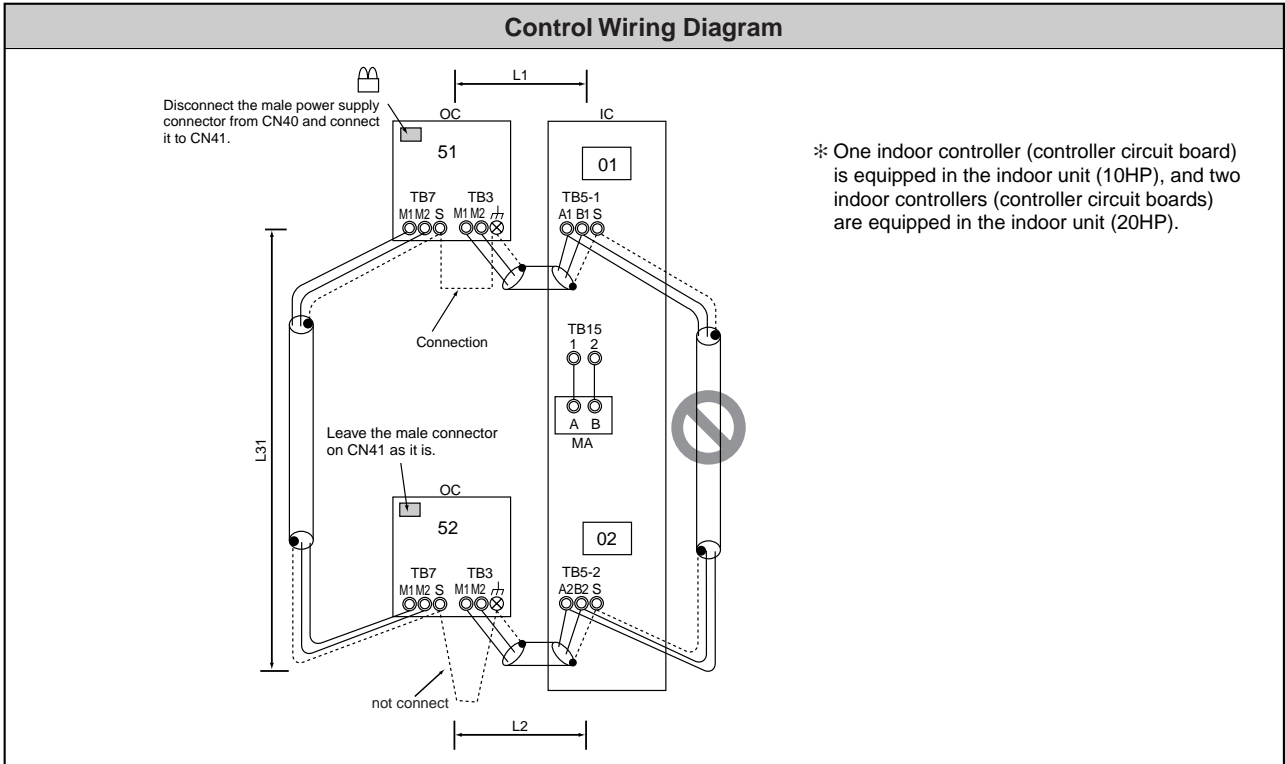

* One indoor controller (controller circuit board) is equipped in the indoor unit (10HP), and two indoor controllers (controller circuit boards) are equipped in the indoor unit (20HP).

Notes	Maximum Allowable Length
<ol style="list-style-type: none"> Assign a sequential number to the outdoor unit. Do not connect the terminal blocks (TB5) of the indoor units connected to different outdoor units. Disconnect the male connector on the controller board from the female power supply switch connector (CN41), and connect it to the female power supply switch connector (CN40) on only one of the outdoor units. Provide grounding to S terminal on the terminal block for transmission line for centralized control (TB7) on only one of the outdoor units. When the power supply unit is connected to the transmission line for centralized control, leave the male connector on the female power supply switch connector (CN41) as it is at factory shipment. The outdoor unit cannot be connected to the units other than the PFD series indoor units. 	<p><a. Indoor/Outdoor transmission line> Maximum Length (1.25mm² or more) L1, L2 ≤ 200m</p> <p><b. Transmission line for centralized control> Maximum Length via outdoor unit (1.25mm² or more) L1 + L31 + L2 ≤ 500m</p>

Wiring and Address Setting

- <a. Indoor/Outdoor transmission line>**
Connect M1, M2 terminals of the indoor/outdoor transmission line terminal block (TB3) on the outdoor unit (OC) and A1, B1 terminals of the indoor/outdoor terminal block (TB5-1) on the indoor unit (IC). (Non-polarized 2-core cable) *Only use shielded cables.
[Shielded cable connection] Connect the earth terminal of the OC and S terminal of the IC terminal block (TB5-1).
- <b. Transmission line for centralized control>**
Daisy-chain terminals M1 and M2 on the terminal block for transmission line for centralized control (TB7) on each outdoor unit (OC).
Disconnect the male connector on the controller board from the female power supply switch connector (CN41), and connect it to the female power supply switch connector (CN40) on only one of the outdoor units. *Only use shielded cables.
[Shielded cable connection] To ground the shielded cable, daisy-chain the S-terminals on the terminal block (TB7) on each of the outdoor units. Connect the S (shielded) terminal on the terminal block (TB7) on the outdoor unit whose male connector on CN41 was disconnected and connected to CN40 to the earth terminal (⌚) on the electric box.
- <c. Switch setting>**
Address setting is required as follows.

Steps	Unit or controller		Address setting range	Address setting method	Notes	Factory setting
1	Indoor unit	Main	IC	01~50	Assign a sequential odd number starting with "01" to the upper indoor controller.	00
		Sub	IC	01~50	Assign sequential numbers starting with the address of the main unit in the same group. (Main unit address +1)	
2	Outdoor unit		OC	51~100	Add 50 to the address assigned to the indoor unit connected to the system with one outdoor unit.	00
3	MA remote controller	Main Controller	MA	Setting not required.	—————	Main
		Sub Controller	MA	Sub Controller	Settings to be made with the sub/main switch	

(1) System with MA remote controller

③ System in which two MA remote controllers are connected to one indoor unit

Control Wiring Diagram

Leave the male connector on CN41 as it is.

* One indoor controller (controller circuit board) is equipped in the indoor unit (10HP), and two indoor controllers (controller circuit boards) are equipped in the indoor unit (20HP).

* One indoor controller (controller circuit board) is equipped in the indoor unit (10HP), and two indoor controllers (controller circuit boards) are equipped in the indoor unit (20HP).

Notes		Maximum Allowable Length	
<ol style="list-style-type: none"> 1. Leave the male connector on the female power supply switch connector (CN41) as it is. 2. Grounding to S terminal on the terminal block for transmission line for centralized control (TB7) is not required. 3. Although two indoor controllers (controller circuit boards) are equipped inside the indoor unit, the board on No.2 side (lower side) is not used. Do not connect wiring to the lower controller circuit board. 4. No more than two MA remote controllers (including both main and sub controllers) can be connected to a group of indoor units. If three or more MA remote controllers are connected, remove the wire for the MA remote controller from the terminal block (TB15). 5. The outdoor unit cannot be connected to the units other than the PFD series indoor units. 	<p><a. Indoor/Outdoor transmission line> Same as (1) ①.</p> <p><b. MA remote controller wiring> Maximum overall length (0.3-1.25mm² or more) $m1 + m2 \leq 200m$</p>		

Wiring and Address Setting

<a. Indoor/Outdoor transmission line>
Same as (1) ①.

<b. MA remote controller wiring>
[When two remote controllers are connected to the system]
 When two remote controllers are connected to the system, connect terminals 1 and 2 of the terminal block (TB15) on the indoor unit (IC) to the terminal block on the MA remote controllers (option).
 *Set the Main/Sub switch on the connected MA remote controllers (option) to SUB.
 (See the installation manual for the MA remote controller for the setting method.)

<c. Switch setting>
Address setting is required as follows.

Steps	Unit or controller	Address setting range	Address setting method	Notes	Factory setting	
1	Indoor unit	Main	IC	01~50	Assign a sequential odd number starting with "01" to the upper indoor controller.	00
	Sub	IC	01~50	Assign sequential numbers starting with the address of the main unit in the same group. (Main unit address +1)		
2	Outdoor unit	OC	51~100	Add 50 to the address assigned to the indoor unit connected to the system with one outdoor unit.	00	
3	MA remote controller	Main Controller	MA	Setting not required.	Main	
	Sub Controller	MA	Sub Controller	Settings to be made with the sub/main switch		

(1) System with MA remote controller

④ System in which two indoor units are grouped with the MA remote controller

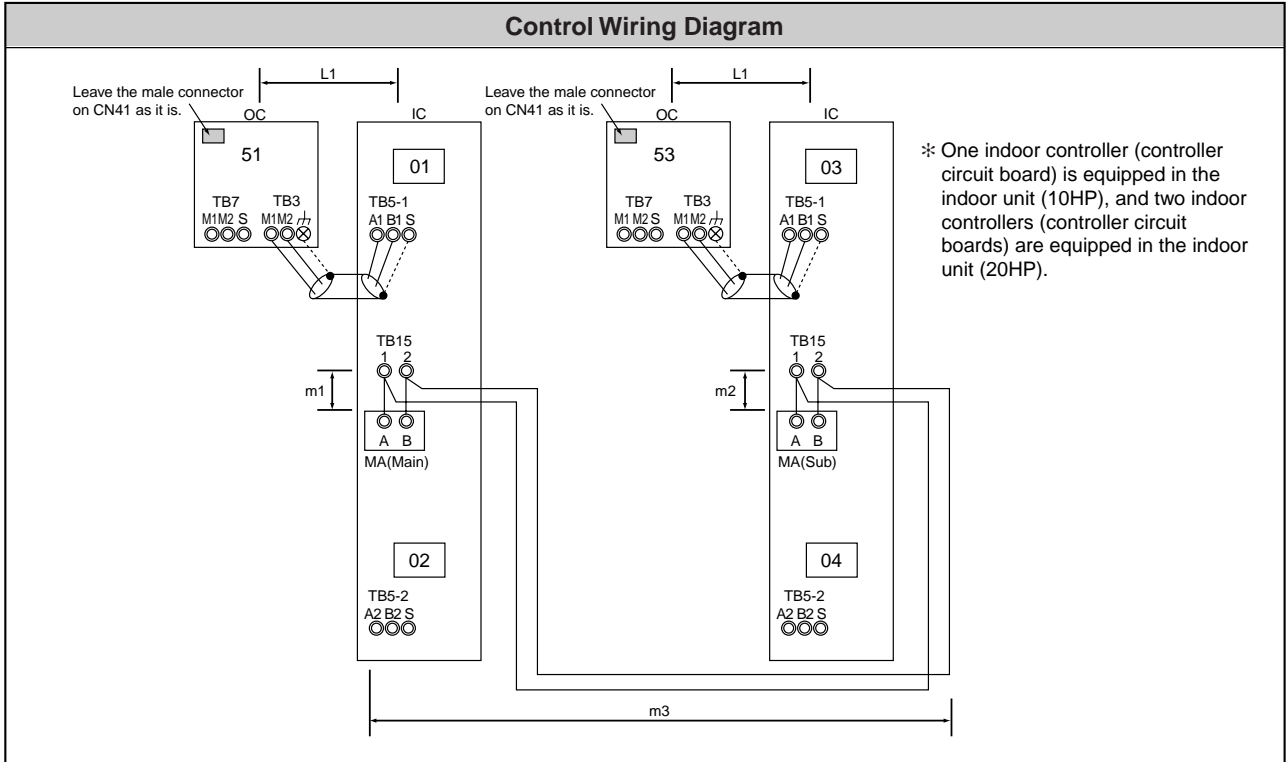

* One indoor controller (controller circuit board) is equipped in the indoor unit (10HP), and two indoor controllers (controller circuit boards) are equipped in the indoor unit (20HP).

Notes		Maximum Allowable Length
<ol style="list-style-type: none"> 1. Leave the male connector on the female power supply switch connector (CN41) as it is. 2. Grounding to S terminal on the terminal block for transmission line for centralized control (TB7) is not required. 3. Although two indoor controllers (controller circuit boards) are equipped inside the indoor unit, the board on No.2 side (lower side) is not used. Do not connect wiring to the lower controller circuit board. 4. No more than two MA remote controllers (including both main and sub controllers) can be connected to a group of indoor units. If three or more MA remote controllers are connected, remove the wire for the MA remote controller from the terminal block (TB15). 5. The outdoor unit cannot be connected to the units other than the PFD series indoor units. 		<p><a. Indoor/Outdoor transmission line> Same as (1) ①.</p> <p><b. MA remote controller wiring> Maximum overall length (0.3-1.25mm² or more) $m1 + m2 + m3 \leq 200m$</p>

Wiring and Address Setting

- <a. Indoor/Outdoor transmission line>**
Same as (1) ①.
- <b. MA remote controller wiring>**
[Group operation of indoor units]
 To perform a group operation of indoor units (IC), daisy-chain terminals 1 and 2 on the terminal block (TB15) on all indoor units (IC). (Non-polarized 2-core cable)
 *Set the Main/Sub switch on one of the MA remote controllers to SUB.
- <c. Switch setting>**
Address setting is required as follows.

Steps	Unit or controller		Address setting range	Address setting method	Notes	Factory setting	
1	Indoor unit	Main	IC	01~50	Assign a sequential odd number starting with "01" to the upper indoor controller.	00	
		Sub	IC	01~50	Assign sequential numbers starting with the address of the main unit in the same group. (Main unit address +1)		
2	Outdoor unit		OC	51~100	Add 50 to the address assigned to the indoor unit connected to the system with one outdoor unit.	To set the address to 100, set the rotary switches to 50.	00
3	MA remote controller	Main Controller	MA	Setting not required.	—	Main	
		Sub Controller	MA	Sub Controller	Settings to be made with the sub/main switch		

(2) System with MA remote controller and AG-150A

① System with multiple indoor units (10HP, 20HP)

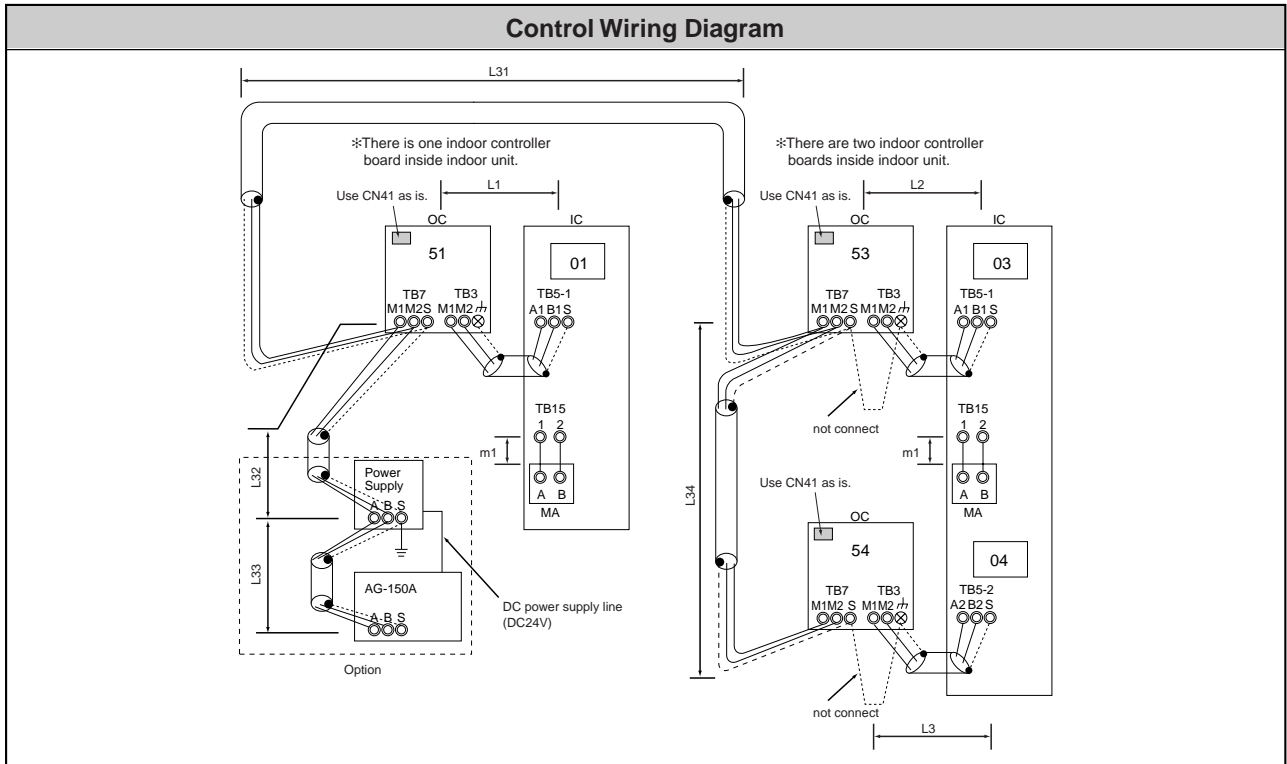

Notes	Maximum Allowable Length
<ol style="list-style-type: none"> Be sure to use odd numbers to set the address for indoor units (10 HP and 20HP connected to the one outdoor unit). To set the indoor unit address for 20 HP connected to two outdoor units, use odd numbers for the top controllers and use even numbers for the bottom controllers (Main controller plus 1). Use the power supply switch connector (CN41) on the outdoor unit as is. It is not necessary to ground the S terminal of transmission line terminal board for centralized controller on the outdoor unit. No more than two main/sub remote controllers can be connected to the indoor unit in the same group. When more than two remote controllers are present in the system, disconnect MA remote controller from TB15 in the indoor unit. Put both types of the addresses for P500-type indoor units in the same group when setting groups for indoor units with system controller (ex. AG-150A). 	<p><a. Indoor/Outdoor transmission line> $L1, L2, L3 \leq 200\text{m}$</p> <p><b. Transmission Line for Centralized Control > $L31 + L32 + L33 + L34 + L3 \leq 500\text{m}$ $L1 + L31 + L34 + L3 \leq 500\text{m}$</p> <p><c. MA Remote Controller Line > Total Length (0.3 ~ 1.25mm²) $m1 \leq 200\text{m}$</p>

Wiring and Address Setting

- <a. Indoor/Outdoor transmission line>**
Same as (1) ①.
- <b. Transmission line for centralized control>**
Daisy-chain terminals M1 and M2 on the terminal block for transmission line for centralized control (TB7) on each outdoor unit (OC).
*Only use shielded cables.
[Shielded cable connection]
To ground the shielded cable, daisy-chain the S-terminals on the terminal block (TB7) on each of the outdoor units.
- <c. Switch setting>**
Address setting is required as follows.

Steps	Unit or controller		Address setting range	Address setting method	Notes	Factory setting
1	Indoor unit	Main (10HP, 20HP)	IC 01~50	Assign a sequential odd number starting with "01" to the upper indoor controller.		00
		Sub (20HP)	IC 02~50	Assign sequential numbers starting with the address of the main unit in the same group. (Main unit address +1)		
2	Outdoor unit		OC 51~100	Add 50 to the address assigned to the indoor unit connected to the system with one outdoor unit.		00
3	MA remote controller	Main Controller	MA Setting not required.	—		Main
		Sub Controller	MA Sub Controller	Settings to be made with the sub/main switch		

7.External input/output specifications

(1) Input/output specifications

Input

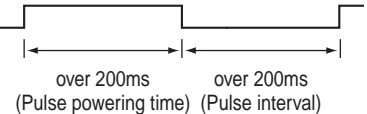
Function	Usage	Signals
Start/stop	Turning ON/OFF the indoor unit	<ul style="list-style-type: none"> · Pulse [Factory setting: Dip SW1-9 ON] (a-contact with voltage/without voltage) ※1 <p><With voltage> Power Source: DC12~24V Electrical Current: Approximately 10mA (DC12V)</p> <p><Standard Pulse></p>  <ul style="list-style-type: none"> · Level [Dip SW1-9 OFF] (Short: operate Open: stop
Dehumidification signal	Sending a command to perform dehumidification with priority	Level Refer to the wiring diagram <Dehumidification command> shown on the page60.

※1 Use minute-current contact (DC12V 1mA)

Output

Function	Usage	Signal
No.1 Operation Status	Obtaining signals indicating operation status of indoor units in each refrigerant circuit.	Relay a-contact output DC 30V or AC 220~240V Standard Current : 1A Minimum Current : 1mA
No. 1 Error Status	Obtaining signals indicating error status of indoor units in each refrigerant circuit.	
No. 2 Operation Status ※	Obtaining signals indicating operation status of indoor units in each refrigerant circuit.	
No. 2 Error Status ※	Obtaining signals indicating error status of indoor units in each refrigerant circuit.	

※ 20HP only

(2) Wiring

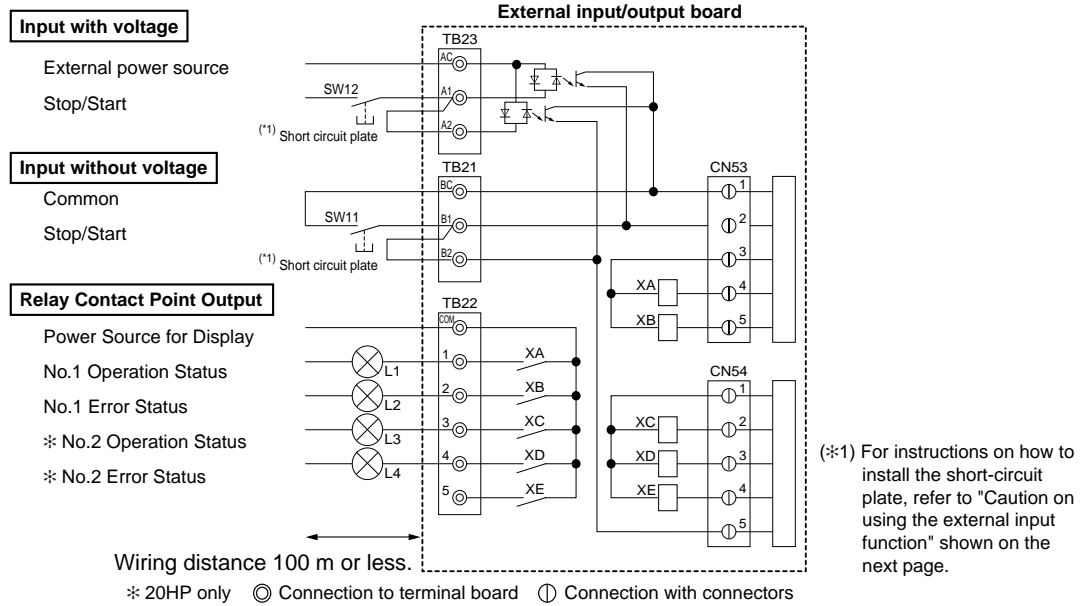

<Input with Applied Voltage>

External power source	DC12~24V Electrical current input (per contact) Approximately 10mA (DC12V)
SW12	Remote start/stop switch Each pressing of the SW (Pulse input) switches between ON and OFF.

<Input without voltage applied>

SW11	Remote start/stop * Each pressing of the SW (Pulse input) switches between ON and OFF.
Contact: Minimum applicable load DC12V 1mA Contact rating DC12V 0.1A and over	

<Relay contact output>

Power supply for displays	DC30V or less 1A AC220-240V 1A	L3	No.2 Operation Status Indicator Lamp
L1	No.1 Operation Status Indicator Lamp	L4	No.2 Error Status Indicator Lamp
L2	No.1 Error Status Indicator Lamp	XA~XE	Relay (Permissible Electrical Current: 10mA~1A)

● Setting on the Indoor Unit

Confirm the following setting when using external input.

- ① No.1, No.2 Controller board Dip SW 3-8: ON (Factory Setting: ON; External input will not be available when OFF.)
- ② No.1, No.2 address board Dip SW 1-10: OFF (Factory Setting: OFF; External input will not be available when ON.)
- ③ Normal/Local switch inside the unit controller box is set to "Normal." (Factory Setting: Normal; External input will not be available when it is set to "Local.")

● **Caution on using the external input function (20HP only)**

⚠ Caution

When using the external input function on the indoor unit that is connected to a two-refrigerant circuit, connect the short-circuit plate that is supplied with the unit to the appropriate terminals on the external input-output board. Without the short-circuit plate, the unit will not function properly. Don't connect the short-circuit plate in case of a one-refrigerant circuit.

· **Connecting the short-circuit plate**

<The case of with-voltage input>

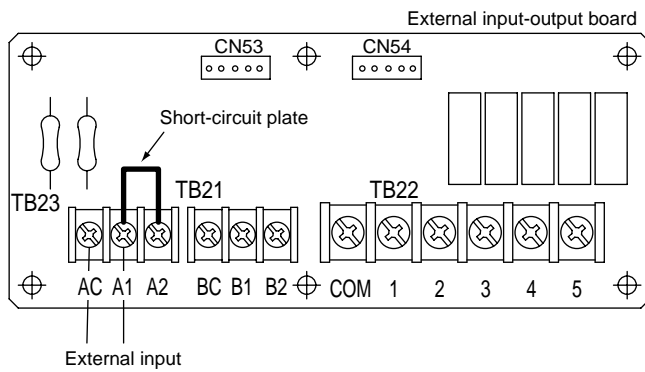

<The case of no-voltage input>

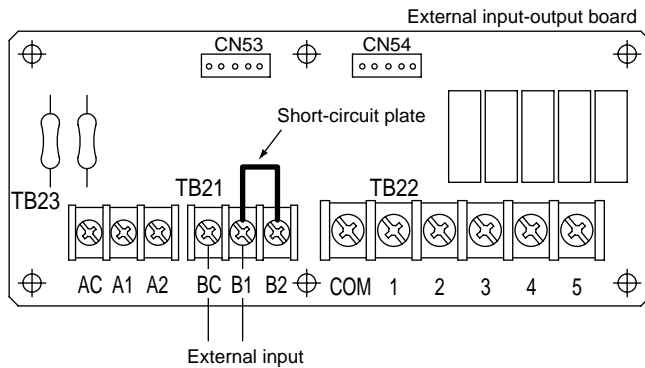

<Dehumidification command>

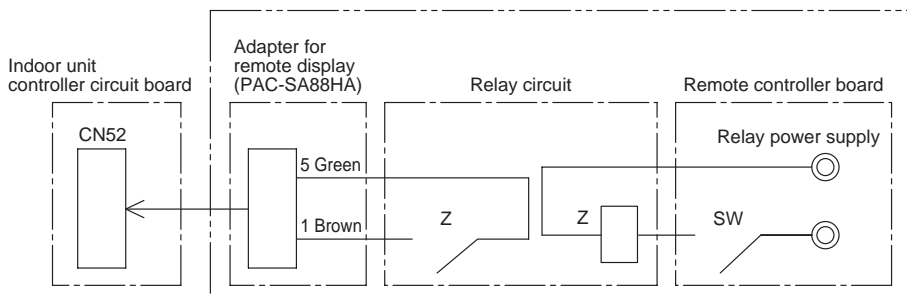

SW: Dehumidification command
 Z: Relay
 (Contact: Minimum applicable load DC12V 1mA)
 Contact rating DC12V 0.1A and over)

(3) Wiring Method

- ① Check the indoor unit setting (Refer to 7-5.(2) Wiring)
- ② When using the external output function, connect each signal line to External output Terminal (TB22) on the unit, depending on the usage.
- ③ When using external input function, peel the outer layer of the signal line off, and connect it to external input terminal (TB21 or TB23) on the unit, depending on the usage.

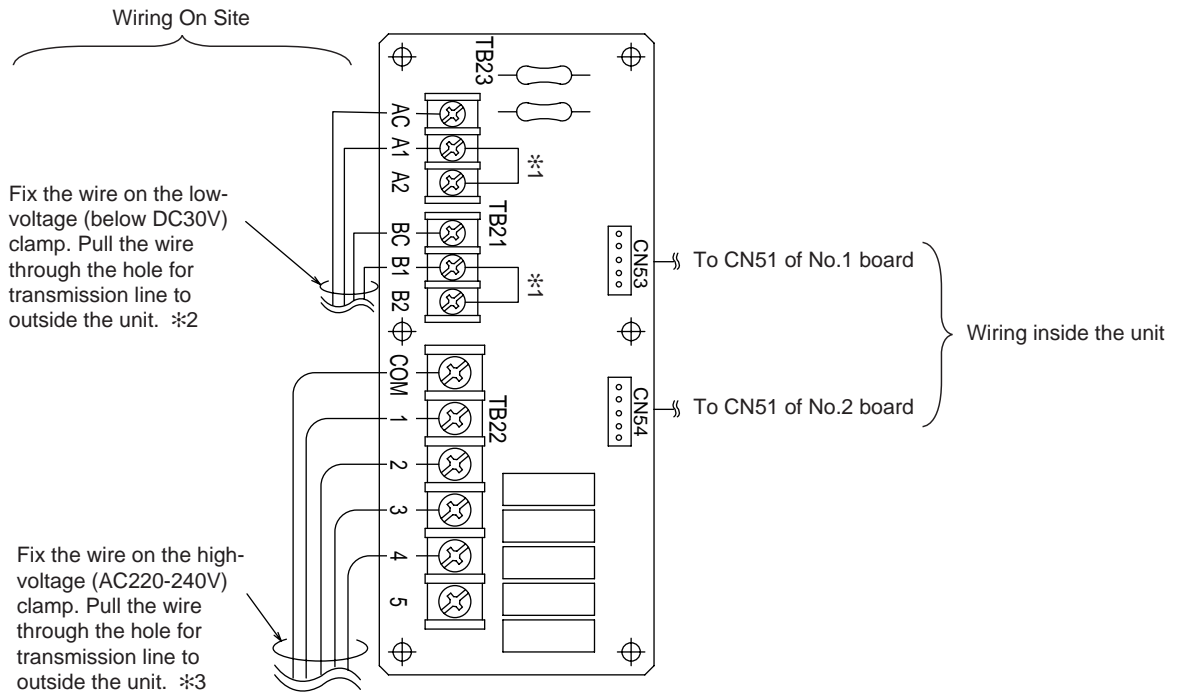

- *1 For instructions on how to install the short circuit plate on the 20HP indoor unit, refer to "Caution on using the external input function" shown on the previous page.
- *2 Do not bundle with high-voltage (AC220-240V) wire, since noise interference from such wire may cause the unit to malfunction.
- *3 Do not bundle with minute-voltage (DC30V or below) wire, since noise interference from such wire may cause the unit to malfunction.

⚠ Caution

- 1) Wiring should be covered by insulation tube with supplementary insulation.
- 2) Use relays or switches with IEC or equivalent standard.
- 3) The electric strength between accessible parts and control circuit should have 2750V or more.
- 4) TB21 is a terminal specifically for No-voltage contact point input. Do not apply voltage to TB21, since it must result in malfunction of indoor unit controller board.
- 5) TB23 is specifically for contact point input with voltage. Check the polarity before connecting to avoid damage to the unit.
- 6) **Keep the wires on the input side and on the output side away from each other when using AC220-240V as a power source for displays.**
- 7) Keep the length of the extension part of external signal line under 100m.
- 8) 20HP is shipped with B1 and B2 terminals of TB21 and A1 and A2 terminals of TB23 short-circuited respectively. Do not eliminate this feature. If it is eliminated, the units in one of the two refrigerant circuits may not operate.

(4) Switch setting

● The suction/discharge temperature control of the indoor unit.

Either suction temperature control or discharge temperature control can be selected .

The suction/discharge temperature control can be switched by the switches (SWC) on the controller circuit board inside the controller of the indoor unit.

The discharge temperature control is selected at factory shipment. (SWC is set to "Standard.")

To switch the control, set SWC on two controller circuit boards inside the controller as follows.

To perform suction temperature control: Set SWC to "Option (OP)"

To perform discharge temperature control: Set SWC to "Standard"

The setting for the SWC on the two controller circuit boards must be the same (applicable only when connecting to a two-refrigerant circuit).

*Only the suction temperature control is performed in the heating mode regardless of the SWC setting.

(5) Dehumidification priority control

This unit can be operated in the dehumidification priority control by receiving external signals (CN52 on indoor unit).

The unit goes into the dehumidification priority control when dehumidification signal is received for 10 continuous minutes during cooling operation. The unit resumes normal operation when the signal goes off or when the suction temperature reaches 13°C or below.

When the unit is in this control, the unit is operated at the maximum capacity regardless of the actual setting, so the room temperature may reach below the preset temperature.

If this is a problem, install a circuit that turns off the dehumidification signal based on the room temperature.

The model of units described in this manual does not support the reheat function, so it does not allow both the temperature and humidity to be controlled simultaneously.

(6) Normal/Local switching switch (SW9)

When selecting the "Local" mode using the Normal/Local switching switch beside the MA remote controller on indoor unit, the local operation is enabled, and the remote ON/OFF operation (external input or system controller) is disabled.

If no external input is available, the local operation is enabled in both "Normal" and "Local" modes.

The occurred error is not reported to the upper system, such as building management system including system controller. (If an error occurs during inspection, the occurred error is reported only to the units, and the error history remains on the units.)

8. System Rotation Control

Applicable Units

Indoor units: PFD-P250, 500VM-E
 Outdoor unit: PUHY-P250YHM-A(-BS), PUHY-P500YHM-A(-BS)
 Heat source unit: PQHY-P250YHM-A

⚠ CAUTION

- To enable this control function, the following wiring and settings are required at installation.
 - 1) Daisy-chain terminals M1 and M2 on the terminal block for transmission line for centralized control (TB7) on all applicable outdoor units.
 Move the power jumper connected to CN41 to CN40 on only one of the outdoor units.
 To supply power to the outdoor unit from a power supply unit, leave the power jumper connected to CN41 as it is (factory setting).
 - 2) Check that the label on the indoor unit circuit board reads KE90D352, if it does not, replace the circuit board.
 - 3) Set the SW1-9 and SW1-10 on indoor units as follows to enable the external input:
 (SW1-9: ON; SW1-10: OFF).
 - 4) Assign sequential addresses to the units as shown below (Figure 1).
 (Only use odd numbers for the 10HP system.)
 - 5) Make the rotation group settings by setting the appropriate switches on the outdoor units.

1. General Descriptions

- Each group can consist of a maximum of 5 systems and a minimum of 2 systems.
- With the use of this control function, one system in a given group serves as a backup and remains stopped.
- The unit designated as the control unit (System 1 in Figure 1) sends command signals to other units in the group to start or stop, and rotates the backup unit every 480 hours.
- Rotation sequence is in the ascending order of address, starting from the lowest address after the control unit address.
 (e.g., System 2 → System 3 → System 4 → System 5 → System 1 in Figure 1 below)
- If other units in the group detect an error or if there is a communication failure between the systems, this control is terminated, and the backup unit goes into operation.

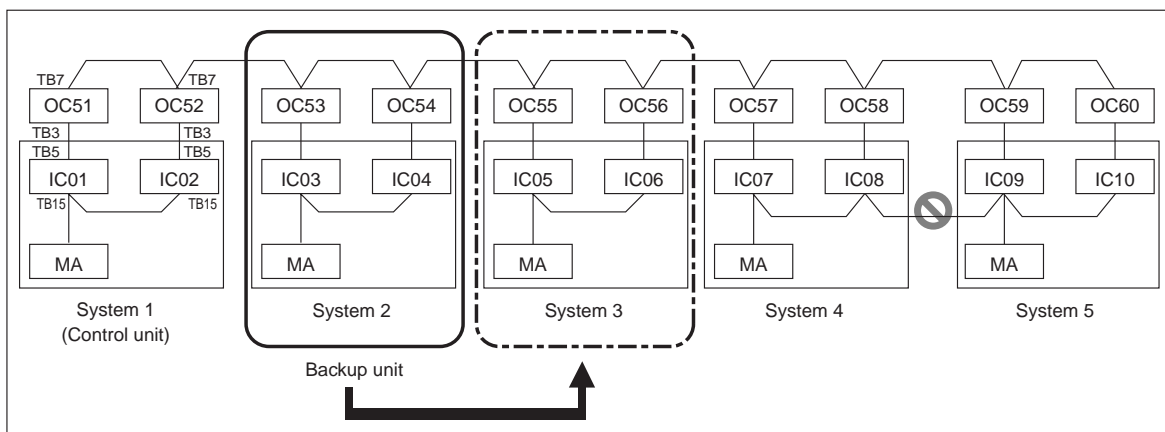

Figure 1 Sample 20HP system group

9. Notes on the use of optional accessories

⚠ WARNING

Only use optional parts recommended by Mitsubishi Electric. These parts should only be installed by a qualified technician. Improper installation may result in water leakage, electric shock, or fire.

10. Caution for refrigerant leakage

The installer and/or air conditioning system specialist shall secure safety against refrigerant leakage according to local regulations or standards. The following standard may be applicable if no local regulation or standard is available.

(1) Refrigerant property

R410A refrigerant is harmless and incombustible. The R410A is heavier than the indoor air in density. Leakage of the refrigerant in a room has possibility to lead to a hypoxia situation. Therefore, the Critical concentration specified below shall not be exceeded even if the leakage happens.

• Critical concentration

Critical concentration hereby is the refrigerant concentration in which no human body would be hurt if immediate measures can be taken when refrigerant leakage happens.

Critical concentration of R410A: 0.30kg/m³
(The weight of refrigeration gas per 1 m³ air conditioning space.);

* The Critical concentration is subject to ISO5149, EN378-1.

For the PFD system, the concentration of refrigerant leaked should not have a chance to exceed the Critical concentration in any situation.

(2) Confirm the Critical concentration and take countermeasure

The maximum refrigerant leakage concentration (R_{max}) is defined as the result of the possible maximum refrigerant weight (W_{max}) leaked into a room divided by its room capacity (V). It is referable to Fig. 8-1. The refrigerant of Outdoor unit here includes its original charge and additional charge at the site.

The additional charge is calculated according to 3-3. "Refrigerant charging calculation", and shall not be over charged at the site. Procedure 8-(2)-1~3 tells how to confirm maximum refrigerant leakage concentration (R_{max}) and how to take countermeasures against a possible leakage.

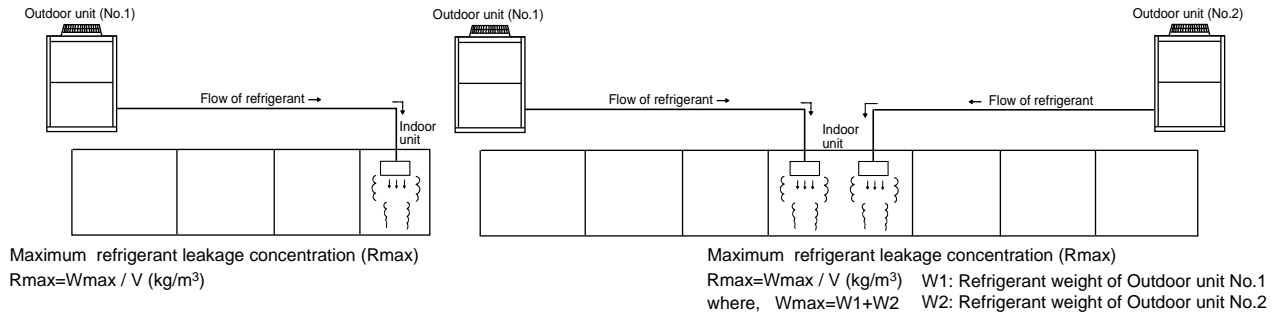

Fig. 8-1 The maximum refrigerant leakage concentration

8-(2)-1. Find the room capacity (V),

If a room having total opening area more than 0.15% of the floor area at a low position with another room/space, the two rooms/space are considered as one. The total space shall be added up.

8-(2)-2. Find the possible maximum leakage (W_{max}) in the room. If a room has Indoor unit(s) from more than 1 Outdoor unit, add up the refrigerant of the Outdoor units

8-(2)-3. Divide (W_{max}) by (V) to get the maximum refrigerant leakage concentration (R_{max}).

8-(2)-4. Find if there is any room in which the maximum refrigerant leakage concentration (R_{max}) is over 0.30kg/m³.

If no, then the PFD is safe against refrigerant leakage.

If yes, following countermeasure is recommended to do at site.

Countermeasure 1: Let-out (making V bigger)

Design an opening of more than 0.15% of the floor area at a low position of the wall to let out the refrigerant whenever leaked. e.g. make the upper and lower seams of door big enough.

Countermeasure 2: Smaller total charge (making W_{max} smaller)

e.g. Avoid connecting more than 1 Outdoor unit to one room.

e.g. Using smaller model size but more Outdoor units.

e.g. Shorten the refrigerant piping as much as possible.

Countermeasure 3: Fresh air in from the ceiling (Ventilation)

As the density of the refrigerant is bigger than that of the air. Fresh air supply from the ceiling is better than air exhausting from the ceiling. Fresh air supply solution refers to Fig. 8-2~4.

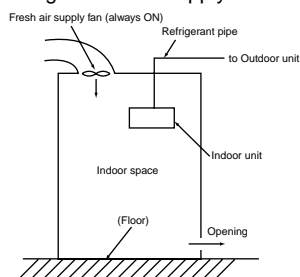

Fig.8-2. Fresh air supply always ON

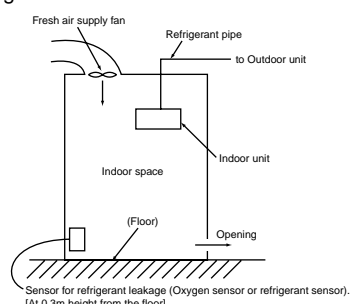

Fig.8-3. Fresh air supply upon sensor action

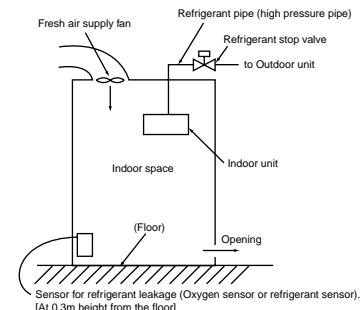

Fig.8-4. Fresh air supply and refrigerant shut-off upon sensor action

Note 1. Countermeasure 3 should be done in a proper way in which the fresh air supply shall be on whenever the leakage happens.

Note 2. In principle, MITSUBISHI ELECTRIC requires proper piping design, installation and air-tight testing after installation to avoid leakage happening.

In the area should earthquake happen, anti-vibration measures should be fully considered.

The piping should consider the extension due to the temperature variation.

V. Air Conditioning the Computer Room

1. Main Features of the Floor-Duct Air Conditioners

This system is installed by building a floor over an existing floor and using the space between these two floors as an air-conditioning duct.

This system has the following characteristics:

- ① The temperature and humidity can efficiently and reliably be controlled, since the air-conditioned air is sent directly to the machine.
- ② It provides a comfortable environment for the operator, since the air can be conditioned to best suit the needs of the operator and machines.
- ③ It is favorable in terms of appearance because the air-conditioning duct is out of sight.
- ④ The location of the duct is irrelevant when considering adding new machines or rearranging the existing machines, since the entire floor serves as the air duct.

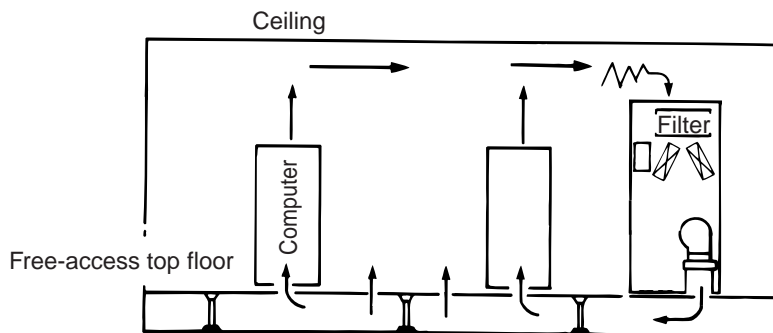

Caution

- (1) Unlike plenum ventilation and overhead-duct type conditioners, since the conditioned air is not mixed with the air in the room, the air that comes out of the unit has to meet the predetermined conditions (constant temperature/constant humidity) at the time the air exits the unit. Close attention must be paid to the auto-controlling system.
- (2) Dust in the duct space (between the free-access top floor and the existing floor) must be thoroughly removed before installing the unit.
- (3) Since the existing floor is cooled by the unit, it may produce dew on the ceiling of the room down below.

2. Features of air-conditioner for computer room

Air-conditioner for computer room is designed to maintain a constant room temperature and humidity. For underfloor air supply systems, providing air that meets predetermined requirements is a must. The compressor installed in this unit runs year around. The capacity controlled compressor regulates the outlet air temperature (or inlet air temperature) depending on the load change. The humidifier (Configure to Order) installed in this unit humidifies a room to a target humidity, and regulates the humidity. With priority dehumidification control (a dehumidifier must be installed on site), a room is dehumidified to a target humidity. Since the reheat function is not equipped, the room temperature may drop below the predetermined temperature due to a load inside the room. Therefore, the absolute humidity drops whereas the relative humidity may not drop to a target humidity.

3.Step-by-Step Plan for the Implementation of the Air-Conditioning

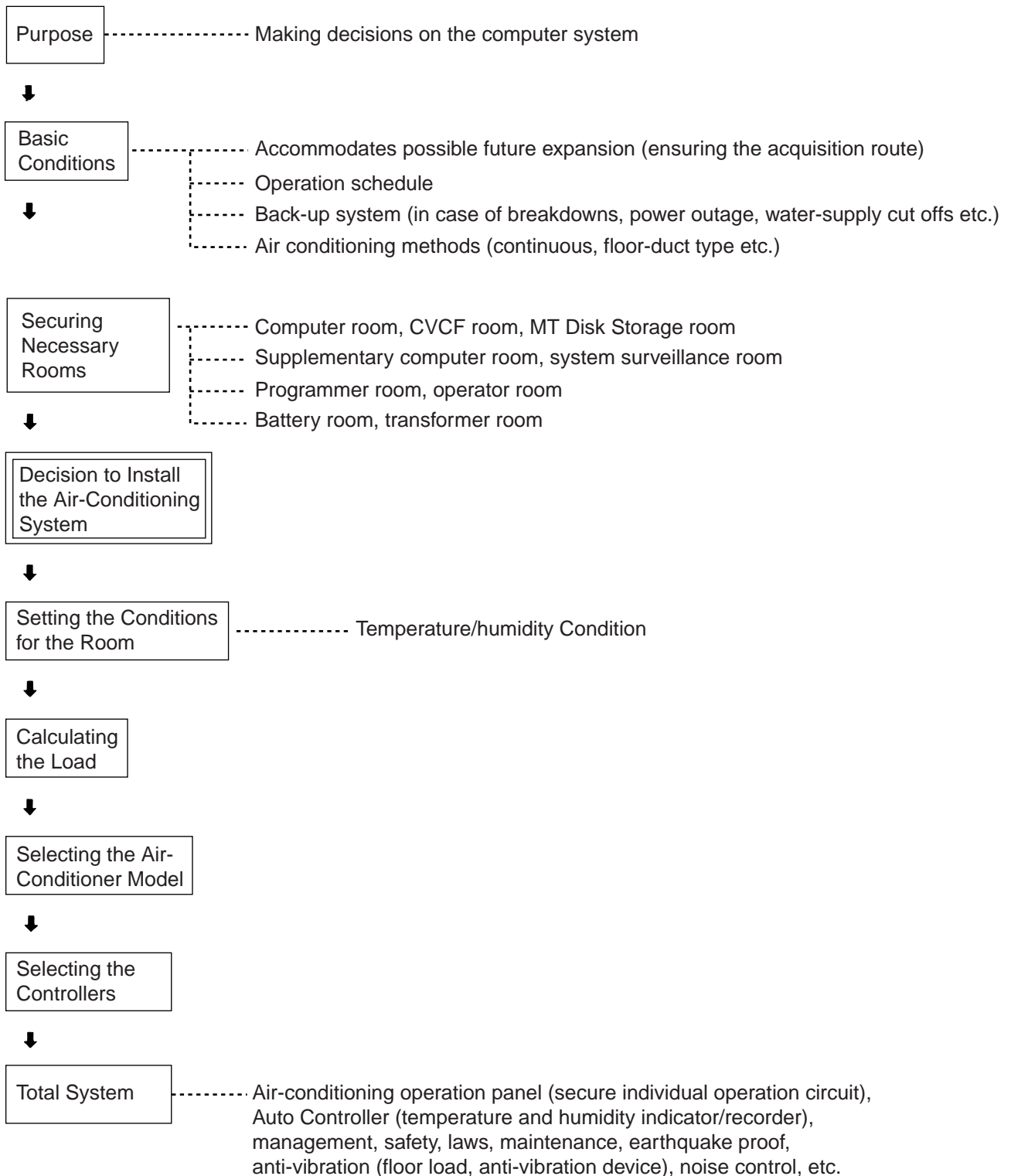

4. Conditions for the Installation of Computer-Room Air Conditioners

(1) Outdoor Temperature and Humidity

Generally the values set for general air conditioners are used, although the value higher than the maximum outdoor temperature and humidity may be set for devices like computer-room air conditioners that must keep the air temperature and humidity under predetermined levels.

(2) Indoor Temperature and Humidity

There is a wide range of conditions set by different computer manufacturers, and the conditions need to be set in consultation with the manufacturers. The most basic conditions include keeping dew condensation and static electricity from forming. It is also necessary to keep the room free of dust to ensure a smooth operation of the computer.

(3) Matching the Volume of Air Flow

It is possible to use the fan on the computer to cool the room. This controlling method requires a certain volume of cold air in proportion to the amount of heat produced by the device. The inlet panel is located at the bottom of the unit, and the exhaust pipe is located either on the ceiling, front and back, or on the side.

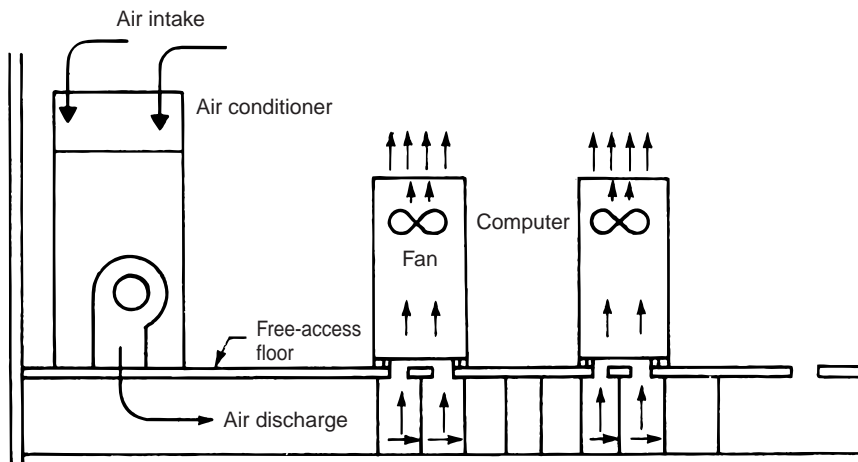

(4) Considering a Back-up Air Conditioning System

When the system is not allowed to stop at all, a back-up system is necessary. There are several different options for a back-up as the following:

- ① Installing two sets of air conditioning systems necessary for the computer.
- ② Utilizing regular office air conditioners (for people)
- ③ Using one of the units as a back-up

① is used infrequently due to high costs involved. ② involves many technical problems such as the difference between preset conditions for computer rooms and office rooms. In general, ③ is a preferred method. If ③ is chosen, the unit method (package method) is more economical than the central method.

5. Setting the Air conditioners

(1) Air-Conditioning Load

- ① Once the floor plan is made and the conditions for the air-conditioning system are set, air conditioning capacity has to be determined by calculating the load.
- ② Unlike the outdoor air, computer load remains constant throughout the year. However, it is possible that there are considerable fluctuations within a day. This is due to the fact that, depending on the time of the day, there are changes in the number of computers that are turned on and that the different computer systems are in operation.
- ③ If there is a plan to expand the current computer system in the future, it is important to include the load for the units to be added in the future when calculating the thermal load because it is practically impossible to keep the computers off for days on end during the installation of the new units.
- ④ The following items need to be checked before calculating the unit capacity:
 - Floor area of the computer room (m²)
 - Total quantity of heat generated by computers

(2) Sample Selection of Air Conditioners

(2-1) Conditions

Computer-generated heat	20.9kW
Number of workers	5
Lighting	20W/m ²
Temperature and humidity	Indoor °CDB/Indoor WBT : 24°C/17°C °CDB of the air going into the computer : 18°C
Frequency	60Hz

(2-2) Building Conditions

Windows	(W: 4.5m, H: 1.5m) × 2
Inside Measurement	Ceiling height 2.2m
Surroundings	Upstairs room, downstairs room, heat and air conditioning

① Coefficient of Overall Heat Transmission U (W/m² ·K)

Outer Walls	Summer 3.6, Winter 3.8
Inner Walls	2.05
Ceiling	Downward convection 3.36, upward convection 3.3
Floor (free access)	Downward convection 3.05, upward convection 4.56
Floor	Downward convection 2.42, upward convection 3.3
Windows	Summer 5.93, Winter 6.5

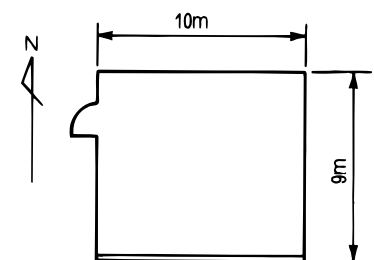

② Internal Load

Number of People in the Room	5
Lighting	20W/m ²
Calculator	20.9kW
Draft	0.2 times/h

③ Volume of Outdoor Air Intake

25m³/h·person

(2-3) Calculating the Load and Selecting a Model

Calculate the temperature difference by setting the outdoor temperature; then, calculate hourly loads.

The chart shows the result of a calculation, supposing that the system reaches its highest load at 12 o'clock.

Outdoor temperatures in this example Summer : 32°CDB relative humidity 60%

Winter : -2°CDB relative humidity 42%

① Load (in the summer with air-conditioning)

< Sensible Heat > SH

Computer		20.9 kW
Lighting	1,800W	1.8 kW
Number of people in the room	5 persons × 64 (U)	0.32 kW
Infiltration draft	(0.2 times/h) 39.6m ³ × 0.336 × 8	0.11 kW
Outer wall (heat transmission)	8.5m ² × 3.6 × 8	0.25 kW
Windows (radiation)	13.5m ² × 0.65 × 188	1.91 kW
Windows (heat transmission)	13.5 × 5.93 × 8	0.64 kW
Inner wall(heat transmission)	61.6 × 2.05 × 4	0.5 kW
Outside air	125m ³ × 0.336 × 8	0.34 kW
Total		26.8 kW

< Latent Heat > LH

Infiltration draft	39.6 × 834 × 0.0117	0.39 kW
Number of people in the room	5 persons × 82	0.41 kW
Outside air	125m ³ × 834 × 0.0117	1.22 kW
Total		2.0 kW

Total load is 28.8kW

② Necessary Air Circulation

$$V = \frac{26800}{0.336 \times (24 - 18)} \div 60 = 221\text{m}^3/\text{min}$$

③ Model Selection

PUHY-P250YHM-A × 2, PFD-P500VM-E type

Indoor °CDB 24°C / Indoor °CWB 17°C outdoor °CDB 32°C

Capacity of the Moment 54.3kW SHF = 0.92

Capacity of Sensible Heat 54.3 × 0.92 = 49.9/kW

Standard Air-Flow Volume: 320m³/min can be accommodated with PUHY-P250YHM-A × 2 and PFD-P500VM-E.

VI. Maintenance / Inspection

1. Maintenance/Inspection Schedule

Having the units inspected by a specialist on a regular basis, in addition to regular maintenance such as changing the filters, will allow the users to use them safely and in good condition for an extended period of time.

The chart below indicates standard maintenance schedule.

(1) Approximate Longevity of Various Parts

The chart shows an approximate longevity of parts. It is an estimation of the time when old parts may need to be replaced or repairs need to be made.

It does not mean that the parts must absolutely be replaced (except for the fan belt).

Please note that the figures in the chart do not mean warranty periods.

Unit	Parts	Check every	Replace after	Daily check	Periodically check	Remarks
Indoor	Fan Motor	6 months	40000 hours		Yes	
	Bearing	6 months	40000 hours		Yes	Add lubricant once a year
	Fan Belt	6 months	8000 hours		Yes	Disposable parts
	Air Filter	3 months	5 years	Yes		Maintenance schedule changes depending on the local conditions
	Drain Pan	6 months	8 years		Yes	
	Drain Hose	6 months	8 years		Yes	
	Linear Expansion Valve	1 year	25000 hours		Yes	
	Heat Exchanger	1 year	5 years		Yes	
	Float Switch	6 months	25000 hours		Yes	
Outdoor Heat source	Display Lamp (LED)	1year	25000 hours		Yes	
	Compressor	6 months	40000 hours		Yes	
	Fan motor	6 months	40000 hours		Yes	
	Linear Expansion Valve	1 year	25000 hours		Yes	
	4-way valve	1 year	25000 hours		Yes	
	Heat Exchanger	1 year	5 years		Yes	
Pressure Switch	1 year	25000 hours		Yes		

(2) Notes

- The above chart shows a maintenance schedule for a unit that is used under the following conditions:
 - A. Less than 6 times per hour of compressor stoppage
 - B. The unit stays on 24 hours a day.
- Shortening the inspection cycle may need to be considered when the following conditions apply:
 - ① When used in high temperature/high humidity area or when used in a place where the temperature and/or humidity fluctuate greatly
 - ② When plugged into an unstable power source (sudden change in voltage, frequency, wave distortions) (Do not exceed the maximum capacity.)
 - ③ When the unit is installed in a place where it receives vibrations or major impacts.
 - ④ When used in a place with poor air quality (containing dust particles, salt, poisonous gas such as sulfuric acid gas and sulfuric hydrogen gas, oil mist).
- Even when the above maintenance schedule is followed, there could be unexpected problems that cannot be predicted.
- Holding of Parts
We will hold parts for the units for at least 9 years after the termination of the production of the unit, following the standards set by the ministry of economics and industries.

(3) Details of Maintenance/Inspection

Unit	Parts	Inspection Cycle	Check points	Assessment	What to do
Indoor	Fan motor	6 months	<ul style="list-style-type: none"> Check for unusual noise Measure the insulation resistance 	<ul style="list-style-type: none"> Free of unusual noise Insulation resistance over 1MΩ 	Replace when insulation resistance is under 1MΩ
	Bearing		<ul style="list-style-type: none"> Check for unusual noise 	<ul style="list-style-type: none"> Free of unusual noise 	If the noise doesn't stop after lubrication, change the oil. Add lubricant once a year.
	Fan belt		<ul style="list-style-type: none"> Check for excessive slack Check for wear and tear Check for unusual noise 	<ul style="list-style-type: none"> Resistance (30~40N/belt) Adequate amount of slack=5mm Belt length=no longer than 102% of the original length Free of wear and tear Free of unusual noise 	Adjust the belt Replace if the belt length exceeds 2% of the original length, worn, or used over 8000 hours
	Air filter	3 months	<ul style="list-style-type: none"> Check for clogging and tear Clean the filter 	<ul style="list-style-type: none"> Clean, free of damage 	Clean the filter Replace if extremely dirty or damaged
	Drain pan	6 months	<ul style="list-style-type: none"> Check for clogging of the drainage system Check for loosened bolts Check for corrosion 	<ul style="list-style-type: none"> Clean, free of clogging Free of loose screws No major disintegration 	Clean if dirty or clogged Tighten bolts Replace if extremely worn
	Drain hose		<ul style="list-style-type: none"> Check for clogging of the drainage system Check for corrosion Check the drainage of the drain trap 	<ul style="list-style-type: none"> Clean, free of clogging Free of wear and tear 	Clean if dirty or clogged Replace if extremely worn Pour water into the drain trap
	Linear expansion valve	1 year	<ul style="list-style-type: none"> Perform an operation check using the operation data 	<ul style="list-style-type: none"> Adequately controls the air temperature 	Replace if malfunctioning
	Heat exchanger		<ul style="list-style-type: none"> Check for clogging, dirt, and damage 	<ul style="list-style-type: none"> Clean, free of clogging or damage 	Clean
	Float switch	6 months	<ul style="list-style-type: none"> Check the outer appearance Make sure its free of foreign objects 	<ul style="list-style-type: none"> Free of frayed or cut wires Free of foreign objects 	Replace if damaged or extremely worn Remove foreign objects
	Display lamp (LED)	1 year	<ul style="list-style-type: none"> Make sure the lamp comes on 	<ul style="list-style-type: none"> Comes on when the output is on Rapid drop in brightness 	Replace if the light does not come on when the power is on
Outdoor / Heat source unit	Compressor	6 months	<ul style="list-style-type: none"> Check for unusual noise Check insulation resistance Check for loosened terminals 	<ul style="list-style-type: none"> Free of unusual sound Insulation resistance over 1MΩ Free of loosened terminals 	Replace if insulation resistance goes below 1MΩ (under the condition that the refrigerant is not liquefied) Tighten loosened bolts
	Fan motor		<ul style="list-style-type: none"> Check for unusual noise Measure insulation resistance 	<ul style="list-style-type: none"> Free of unusual sound Insulation resistance over 1MΩ 	Replace if insulation resistance goes below 1MΩ
	Linear expansion valve	1 year	<ul style="list-style-type: none"> Perform an operation check using the operation data 	<ul style="list-style-type: none"> Adequately controls the air temperature 	Replace if malfunctioning
	4-way valve		<ul style="list-style-type: none"> Perform an operation check using the operation data 	<ul style="list-style-type: none"> Adequately controls the refrigerant temperature when the valve is switched (Check temperature change when cooling/heating is switched.) 	Replace if malfunctioning
	Heat exchanger		<ul style="list-style-type: none"> Check for clogging, dirt, and damage 	<ul style="list-style-type: none"> Clean, free of clogging or damage 	Clean
	Pressure switch		<ul style="list-style-type: none"> Check for torn wire, fraying, and unplugged connectors Check insulation resistance 	<ul style="list-style-type: none"> No frayed or cut wires or unplugged connectors Insulation resistance over 1MΩ 	Replace when cut or shorted, when the insulation resistance goes below 1MΩ, or if there is a history of abnormal operation

DATA BOOK **PUHY-P250YHM-A**
PUHY-P500YSHM-A
PQHY-P250YHM-A
PFD-P250VM-E
PFD-P500VM-E