

mitsubishi electric

Air Conditioning For Building Application

Drain Water Lift-Up Kit PAC-KE05DM-F



Installation Manual

This installation manual contains only the description of how to install the Drain water Lift-Up Kit PAC-KE05DM-F. For information about how to wire and how to install air conditioning units, see the installation manual for them.

For your safety, first be sure to read "1 Safety Precautions" described below thoroughly and then install the Drain water Lift-Up Kit PAC-KE05DM-F correctly.

1 Safety Precautions

- The following two symbols are used to denote dangers that may be caused by incorrect use and their degree:

 WARNING	This symbol denotes what could lead to serious injury or death if you misuse the PAC-KE05DM-F.
 CAUTION	This symbol denotes what could lead to a personal injury or damage to your property if you misuse the PAC-KE05DM-F.

- After reading this installation manual, keep it in a place where the final user can see it anytime he or she wants to it. When someone moves, repairs or uses the PAC-KE05DM-F, make sure that this manual is forwarded to the final user.

WARNING

Always have the unit installed by Authorized Mitsubishi Representative or similar professional.
Improper installation by the user could result in problems such as water leakage, electric shock or fire.

Install the unit according to this Installation Manual.
If the unit is installed improperly, water leakage, electric shock or fire may result.

Always use the designated cables and connect them properly. When connecting the terminals, make sure that external forces from the cable is not being conveyed to the terminal and then tighten it securely.
Improper or loose connections could cause excessive heat or fire.

Have all electric work performed by a properly licensed electrician. Electric work should be performed in strict adherence to procedures to this Installation Manual. Always provide a dedicated power supply.
If the capacity of the power supply is inadequate, it could result in problems such electric shock or fire.

Only use Mitsubishi-approved accessories, such as an air cleaner, humidifier or electric heater.
Always have such accessories installed by an Authorized Mitsubishi Representative or similar professional. Improper installation by the user may result in water leakage, electric shock or fire.

Never modify the unit and always have repairs performed by an Authorized Mitsubishi Representative.
Improper repair could result in problems such water leakage, electric shock or fire.

CAUTION

PRECAUTIONS BEFORE INSTALLATION

Never use for special applications such as storing food, plants, precision equipment or art.
The quality of these items may deteriorate.

Always provide adequate signal noise protection when installing in facilities such as hospitals and communication stations.

Equipment at these facilities, such as inverters, in-house generators, high-frequency medical equipment, two-way communication equipment, may cause the air conditioner to operate improperly. Conversely, the signal noise from the air conditioner may affect the operation of medical equipment and two-way communication equipment and this could interfere with the medical treatment being given a patient or cause disturbances or interference in video broadcasting equipment.

Never use the unit in special environments.
Special environments with high concentrations of oil, steam or sulfuric gases will reduce the performance of the air condition and cause its parts to deteriorate.

Never install the unit where run-off could result in damage.
If the humidity in the room exceeds 80% or if the drain becomes clogged, water may drain off of the indoor unit. When the unit is used for heating, there may be drainage from the outdoor unit. If required, provide collector drain for the outdoor unit.

PRECAUTIONS BEFORE REMOVE AND ELECTRIC WORK

Route wiring so that there is no tension.
Tension could cause the wire to break and this could result in excessive heat or fire.

Use care when transporting the unit.

- Always use two or more people for lifting a product weight 20 kg. or more.
- Some products are packaged with plastic wrapping bands. Never use these for lifting or transporting the product.
- Never touch the fins on the heat exchanger. They are sharp and could cause cuts.
- Never allow children to play with the plastic bags used for packaging. Always tear them up when disposing. A child could suffocate in these bags.

Dispose of packing materials properly.

PRECAUTIONS BEFORE TEST RUN

Never touch the switch with wet hands.
Electric shock could occur.

Never operate the air conditioner with the air filter removed.
Particles will enter into the air conditioner and cause damage.

Never operate the air conditioner with the panel or guard removed.
The hand could come in contact with rotating, hot or high-pressure components. They could cause electrical shock or entanglement.

Never turn off the power supply immediately after stopping the unit.
Wait five minutes or more before turning off the power supply. Turning off the power supply before that time could result in water leakage or damage.







2 Confirming the Supplied Parts

1. Model names and applicable models

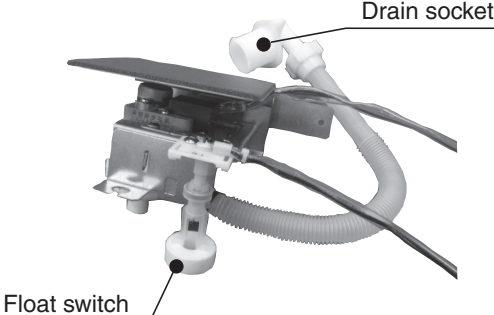
Model name	Applicable types
PAC-KE05DM-F	PEFY-P200VMHS-E, PEFY-P250VMHS-E PEFY-P72NMHSU-E, PEFY-P96NMHSU-E

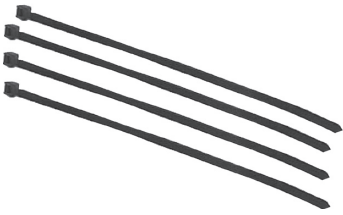
2. Provided parts

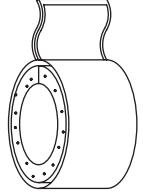
Check that the packet includes the following parts in addition to this installation manual.

PARTS	① DRAIN PUMP ASSY.		② RUBBER PLUG	
SHAPE				
QTY	1		1	
PARTS	③ BAND (Small)	④ BAND (Large)	⑤ INSULATION PIPE	
SHAPE				
QTY	4	1	1	
PARTS	⑥ PTT SCREW 4x10			
SHAPE				
QTY	4 + 1 (spare)			

3 Attach the Drain Pump

The drain pump must be attached before installation of the indoor unit.

3-1 Preparation for the indoor unit

- (1) Remove the fixing screws (5 locations) shown Photo 3-1, and remove the control box cover and the wire cover.

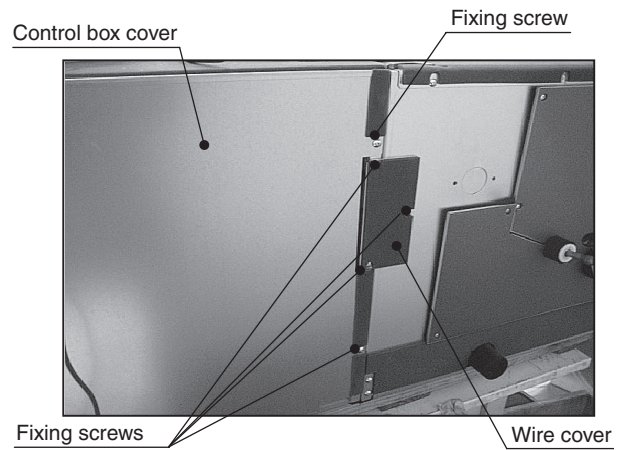

Photo 3-1

- (2) Remove the fixing screws (3 locations) shown in Photo 3-2, and remove the heat exchanger cover.

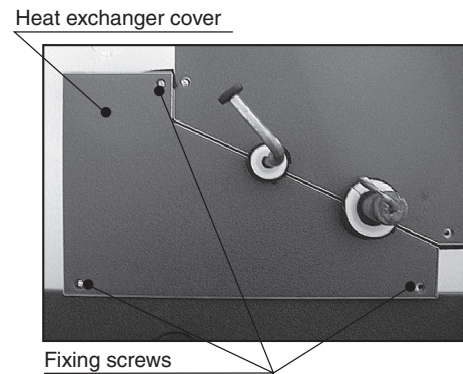

Photo 3-2

- (3) Open the knockout hole shown in Photo 3-3 using a screwdriver etc.

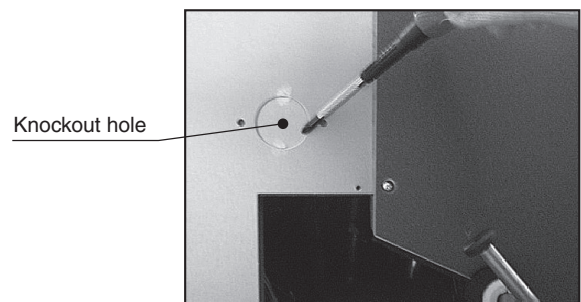

Photo 3-3

3-2. Attach the drain pump

(1) Attach the drain pump ① and drain socket as shown in Photo 3-4 using four PTT screws ⑥.

* When attaching the drain socket, make sure that drain hose is straight.

(2) Insert the rubber plug ② into the drain port to close the port.

* To prevent water leakage, make sure that the rubber plug is pushed in firmly as far as it will go.

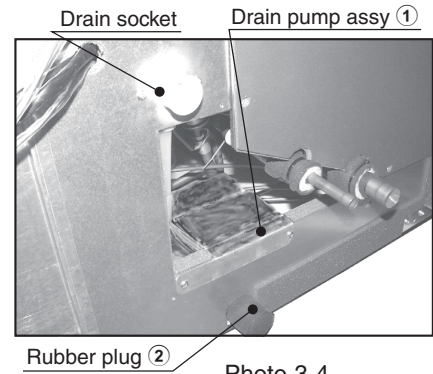
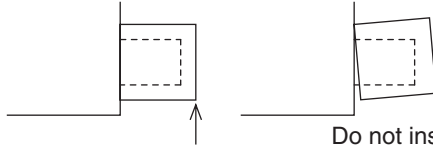

Photo 3-4



Insert the rubber plug straight.

Do not insert the rubber plug obliquely.

3-3. Attaching the drain socket

As shown in the drawing below, insert the drain socket into the knockout hole, and fix it with the PTT screw ⑥.

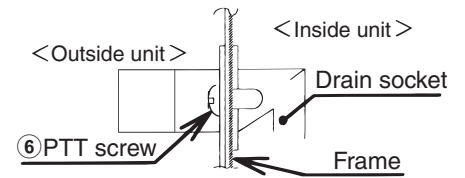

Fig.3-1

4 Wiring

4-1. Passing the pump wires (Photo 4-1)

- Pass the 2-wire cord (with a blue connector) through the hole shown in the photo.
- Pass the 2-wire cord (with a white connector) through the pipe sensor and LEV lead wire hole.

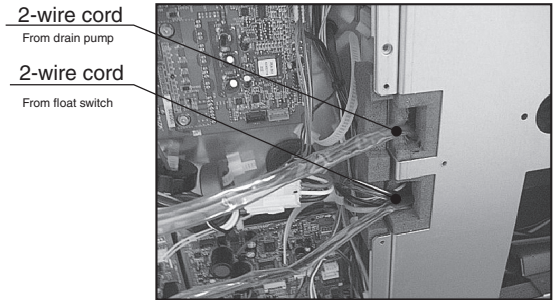

Photo 4-1

4-2. Connecting the pump wires to the control box of the indoor unit (Fig. 4-1)

- Connect the blue connector of the 2-wire cord to CNP on the noise filter board inside the control box.
- Insert the white connector of the 2-wire cord into CN4F on the indoor P.C. board. Since a connector has been inserted into both CNP and CN4F before shipment, they must be removed.
- When wiring is complete, fasten the remaining cords with the band (small) ③.

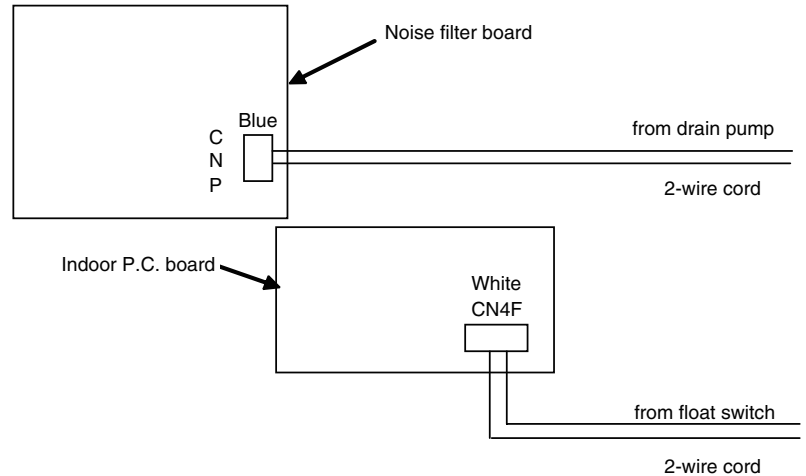

Fig. 4-1

When fastening lead wires

Power wires and low-voltage wires are separately bundled inside the control box to reduce noise interference. Lead wires from the Drain Water Lift-Up Kit also need to be bundled separately. Follow the steps below to hold them and the lead wires inside the control box together.

(1) Power wires

* Feed the lead wires from the drain pump through the wire saddle as shown with "A" in Photo 4-2.

* Bundle the excess lead wires from the drain pump, and clip them together with a cable clip as shown in Photo 4-3.

(2) Low voltage wires

* Bundle the excess lead wires from the float switch, then keep them, pipe sensor lead wires, and LEV lead wires together with a band (small) ③ as shown in Photo 4-4.

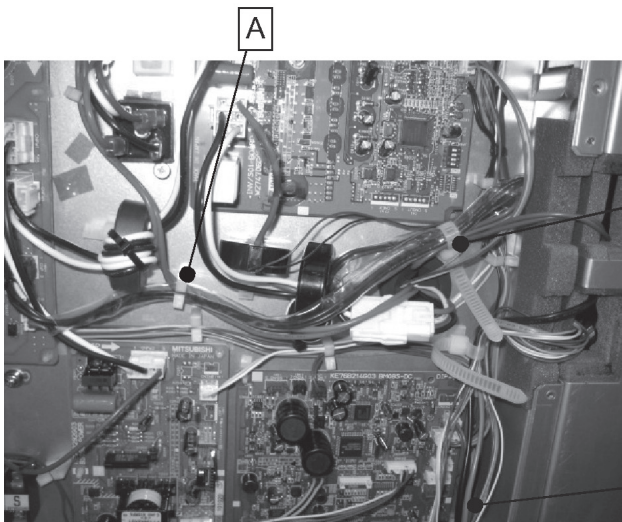

Photo 4-2

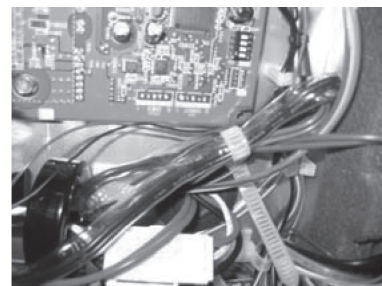

Photo 4-3



Photo 4-4

5 Drain piping work

Be sure to wind commercially available insulating material (with a form polyethylene's specific gravity of 0.03 and thickness given below) onto all pipes which pass through rooms.

- ① Select the thickness of insulating material by pipe size.

Pipe size	Insulating material's thickness
6.4 mm to 25.4 mm	More than 10 mm
28.6 mm to 38.1 mm	More than 15 mm

- ② If the unit is used on the highest story of a building and under conditions of high temperature and humidity, it is necessary to use pipe size and insulating material's thickness more than those given in the table above.
- ③ If there are customer's specifications, simply follow them.

1. Ensure that the drain piping is downward (pitch of more than 1/100) to the outdoor (discharge) side. Do not provide any trap or irregularity on the way. (Fig. 5-1)
2. Ensure that any cross-wise drain piping is less than 20 meters (excluding the difference of elevation). If the drain piping is long, provide support bracket to prevent it from waving. Never provide any air vent pipe. Otherwise drain may be ejected.
3. Use a hard vinyl chloride pipe $\phi 32$ mm (1-1/4 inch) for drain piping.
4. Ensure that collected pipes are 10 cm lower than the unit body's drain port. (Fig. 5-2)
5. Do not provide any odor trap at the drain discharge port.
6. Put the end of the drain piping in a position where no odor is generated.
7. Do not insert the end of the drain piping into any sewer where sulfuric gases are generated.
8. The intake of the drain piping can be made 700 mm higher than the Indoor unit. If there are some obstacles under the ceiling, use elbows to make it at least height according to the site. (Fig. 5-3)
9. Be sure to use the supplied drain hose (Accessory). Connect each connection with vinyl chloride adhesive. Otherwise the Drain Water Lift-Up Kit cannot be serviced later. Also, the end connection may be eroded by resin and so cracked.

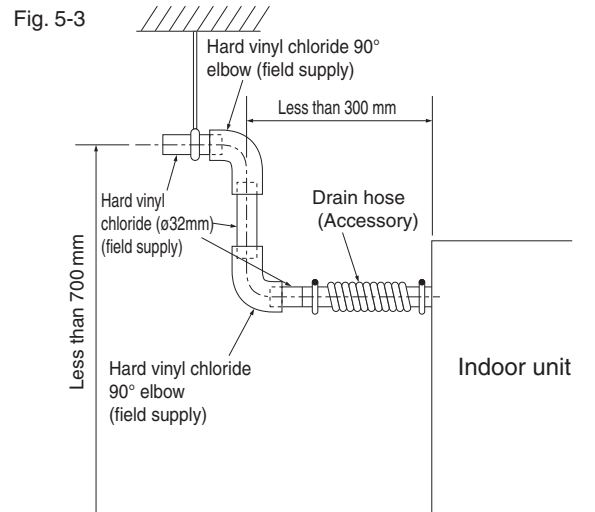
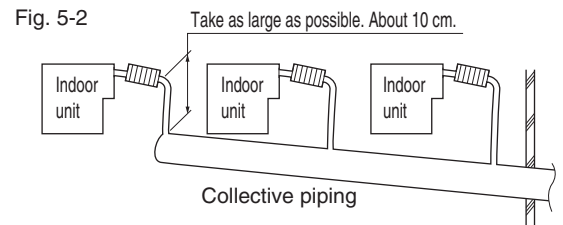
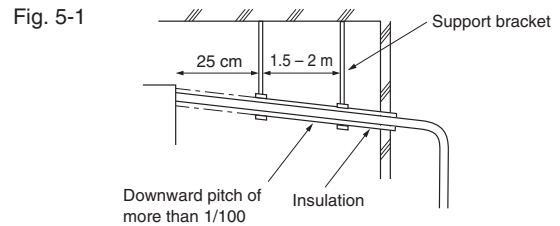

Take the following steps to install the drain hose.

1. Insert the drain hose (supplied with the indoor unit) into the drain port.
(The drain hose must not be bent more than 45° to prevent the hose from breaking or clogging.)
2. Attach the drain pipe (O.D. $\phi 32$ PVC TUBE, field supply).
(Attach the pipe with glue for the hard vinyl chloride pipe, and fix it with the band (small) ③.)
3. Perform insulation work on the drain pipe (O.D. $\phi 32$ PVC TUBE) and on the socket (including elbow).
4. Follow the steps in the next section to confirm the drain discharge.
5. Wrap the insulation pipe ⑤ around the connection part between the drain socket and the drain hose, and then install the band (large) ④.

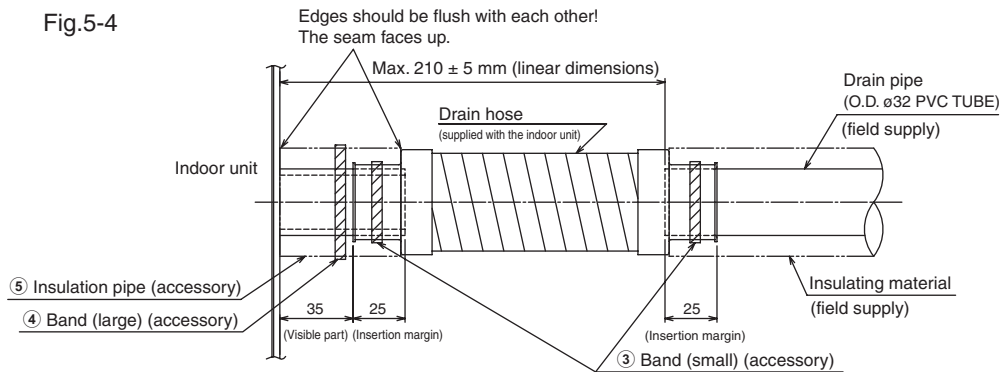

Note:

If the rise portion is long, there will be a lot of returned water in an operation stop, generating slime or odor during off-season. Ensure that the rise portion is at a minimum.

⚠ Caution:

Pipe the drain piping to ensure that it discharges drain, and insulate it to prevent dew condensation. A failure to the piping work may cause water leakage and so wet your property.

6 Confirming drain discharge

► **Make sure that the Drain Water Lift-Up Kit operates normally for discharge and that there is no water leakage from the connections.**

- Be sure to confirm the above in a period of heating operation.
- Be sure to confirm the above before ceiling work is done in the case of a new construction.
- **Before pouring water, be sure to confirm again the rubber plug is pushed in straight all the way.**

1. Set the SWE of the control board inside the control box to ON.

2. Remove the heat exchanger cover from the indoor unit.
(Refer to 3-1 (2).)

3. Pour water into the drain pan using a kettle etc. (Approx. 2 to 3 l)
When pouring, make sure that the spout of the kettle is placed into the drain pan to prevent water overflowing from the drain pan. (If the spout of the kettle is not placed properly, the water will be poured outside of the unit.) (Photo 6-1)

(Note 1) If the drain discharge cannot be confirmed even after the amount of water described above was poured, the unit may be inclined reversely. Check that the unit is installed properly (horizontally) with a level. Also, pouring too much water will immerse the drain pump in water and pose a risk of malfunctions.

(Note 2) If a submersible pump is used to pour water, adjust the water amount with a valve so that the water amount will not exceed 0.4 l/min. Pouring too much water may result in water leakage from the indoor unit and malfunctions of the drain pump.

4. Turn on the main power of the indoor unit.

The drain pump will be forced to operate even if no remote controller operation is performed.

Check the transparent drain hose to make sure that drain is discharged.

5. When it is confirmed that drain is discharged properly, turn off the main power, and set the SWE to OFF.

Check that all the wiring work has been completed. If so, reassemble the drain pipe in reverse order.

(Refer to 3-1 (2)→(1).)

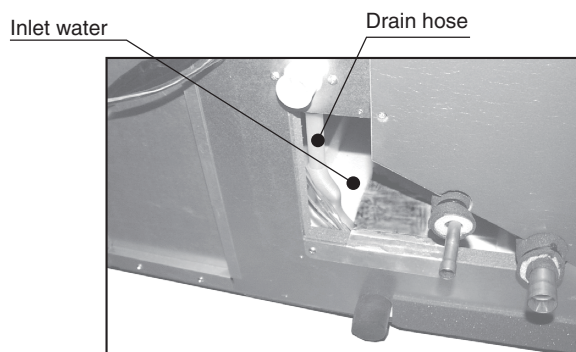

Photo 6-1