

# SERVICE MANUAL

## R410A

[Model name]

EHST20C-VM6HA

EHST20C-YM9HA

EHST20C-VM6A

EHST20C-YM9A

EHST20C-VM6SA

EHPT20X-VM2HA

EHPT20X-VM6HA

EHPT20X-YM9HA

EHPT20X-VM6A

EHPT20X-YM9A

[Service Ref.]

**EHST20C-VM6HA.UK**

**EHST20C-YM9HA.UK**

**EHST20C-VM6A.UK**

**EHST20C-YM9A.UK**

**EHST20C-VM6SA.UK**

**EHPT20X-VM2HA.UK**

**EHPT20X-VM6HA.UK**

**EHPT20X-YM9HA.UK**

**EHPT20X-VM6A.UK**

**EHPT20X-YM9A.UK**

Note:

- This manual describes only service data of cylinder unit.
- RoHS compliant products have <G> mark on the spec name plate.

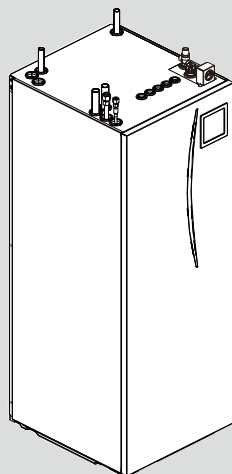

CYLINDER UNIT

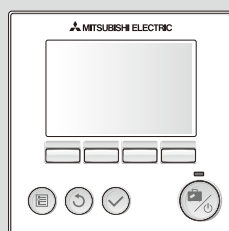

MAIN CONTROLLER

## CONTENTS

1. REFERENCE MANUAL.....	2
2. SAFETY PRECAUTION.....	3
3. SPECIFICATIONS.....	7
4. PART NAMES AND FUNCTIONS .....	8
5. OUTLINES AND DIMENSIONS.....	10
6. WIRING DIAGRAM.....	11
7. FIELD WIRING.....	21
8. WATER SYSTEM DIAGRAM.....	25
9. CONTROLS .....	28
10. TROUBLESHOOTING.....	43
11. DISASSEMBLY PROCEDURE.....	56
12. SUPPLEMENTARY INFORMATION .....	72
13. SERVICE AND MAINTENANCE .....	73

**PARTS CATALOG (OCB507)**

## OUTDOOR UNIT'S SERVICE MANUAL

Service Ref.	Service Manual No.
PUHZ-RP35/50/60/71VHA4	OCH451
PUHZ-RP100/125/140VKA	
PUHZ-RP100/125/140YKA	
PUHZ-HRP71/100VHA	OCH425
PUHZ-HRP71/100VHA2	
PUHZ-HRP71/100VHA2R1	
PUHZ-HRP100VHA2R2	
PUHZ-HRP100/125YHA	
PUHZ-HRP100/125YHA2	
PUHZ-HRP100/125YHA2R1	OCH439
PUHZ-W50/85VHA	
PUHZ-W50/85VHA-BS	
PUHZ-W85VHAR1	
PUHZ-W85VHAR1-BS	OCH465
PUHZ-W85VHA2.UK	
PUHZ-W85VHA2-BS.UK	OCH439
PUHZ-HW112/140YHA	
PUHZ-HW112/140YHA-BS	
PUHZ-HW112/140YHA2	
PUHZ-HW112/140YHA2-BS	
PUHZ-HW140VHA	
PUHZ-HW140VHA-BS	
PUHZ-HW140VHA2	
PUHZ-HW140VHA2-BS	
PUHZ-HW140VHA2R1-BS	

Please read the following safety precautions carefully.

**⚠ WARNING:**  
Precautions that must be observed to prevent injuries or death.

**⚠ CAUTION:**  
Precautions that must be observed to prevent damage to unit.

**This installation manual along with the user manual should be left with the product after installation for future reference. Mitsubishi Electric is not responsible for the failure of locally or field-supplied parts.**

- Be sure to perform periodical maintenance.
- Be sure to follow your local regulations.
- Be sure to follow the instructions provided in this manual.

### ⚠ WARNING

#### Mechanical

- The cylinder unit and outdoor units must not be installed, disassembled, relocated, altered or repaired by the user. Ask an authorised installer or technician. If the unit is installed improperly or modified after installation by the user, water leakage, electric shock or fire may result.
- The outdoor unit should be securely fixed to a hard level surface capable of bearing its weight.
- The cylinder unit should be positioned on a hard vertical surface capable of supporting its filled weight to prevent excessive sound or vibration.
- Do not position furniture or electrical appliances below the outdoor unit or cylinder unit.
- The discharge pipework from the emergency/safety devices of the cylinder unit should be installed according to local law.
- Only use accessories and replacement parts authorised by Mitsubishi Electric and employ a qualified technician to fit the parts.

#### Electrical

- All electrical work should be performed by a qualified technician according to local regulations and the instructions given in this manual.
- The units must be powered by a dedicated power supply and the correct voltage and circuit breakers must be used.
- Wiring should be in accordance with national wiring regulations. Connections must be made securely and without tension on the terminals.
- Earth unit correctly.

#### General

- Keep children and pets away from both the cylinder unit and outdoor units.
- Do not use the hot water produced by the heat pump directly for drinking or cooking. This could cause illness to the user.
- Do not stand on the units.
- Do not touch switches with wet hands.
- Annual maintenance checks on both the cylinder unit and the outdoor unit should be done by qualified person.
- Do not place items containing liquid in on top of the cylinder unit. If they leak or spill onto the cylinder unit, damage to the unit and/or fire could occur.
- Do not place any heavy items on top of the cylinder unit.
- When installing or relocating, or servicing the cylinder unit, use only the specified refrigerant (R410A) to charge the refrigerant lines. Do not mix it with any other refrigerant and do not allow air to remain in the lines. If air is mixed with the refrigerant, then it can be the cause of abnormal high pressure in the refrigerant line, and may result in an explosion and other hazards.
- The use of any refrigerant other than that specified for the system will cause mechanical failure or system malfunction or unit breakdown. In the worst case, this could lead to a serious impediment to securing product safety.

### ⚠ CAUTION

- Use clean water that meets local quality standards on the primary circuit.
- The outdoor unit should be installed in an area with sufficient airflow according to the diagrams in the outdoor unit installation manual.
- The cylinder unit should be located inside to minimise heat loss.
- Water pipe-runs on the primary circuit between outdoor and indoor unit should be kept to a minimum to reduce heat loss.
- Ensure condensate from outdoor unit is piped away from the base to avoid puddles of water.
- Remove as much air as possible from water circuit.
- Refrigerant leakage may cause suffocation. Provide ventilation in accordance with EN378-1.
- Be sure to wrap insulation around the piping. Direct contact with the bare piping may result in burns or frostbite.
- Never put batteries in your mouth for any reason to avoid accidental ingestion.
- Battery ingestion may cause choking and/or poisoning.
- Install the unit on a rigid structure to prevent excessive sound or vibration during operation.
- If power to the cylinder unit is to be turned off (or system switched off) for a long time, the water should be drained.
- Preventative measures should be taken against water hammer, such as installing a Water Hammer Arrestor on the primary water circuit, as directed by the manufacturer.

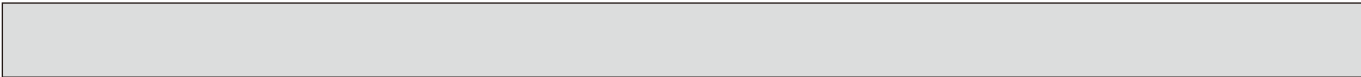

**⚠ WARNING (SPLIT MODELS ONLY)**

Do not discharge refrigerant into the atmosphere. If refrigerant leaks during installation, ventilate the room.

Use appropriate tools for high pressure refrigerant.

When pumping down refrigerant, stop the compressor before disconnecting the refrigerant pipes.

During installation securely fasten the refrigerant pipes before starting the compressor.

Check that refrigerant gas does not leak after the completion of installation.

Use R410A refrigerant only. Do not allow air to enter the lines. Failure to observe these instructions will cause mechanical failure, system failure or, in the worst case, serious breach of product safety.

**⚠ CAUTION (SPLIT MODELS ONLY)**

<Using R410A refrigerant heat pumps>

Use C1220 copper phosphorus, for copper and copper alloy seamless pipes, to connect the refrigerant pipes. Make sure the insides of the pipes are clean and do not contain any harmful contaminants such as sulfuric compounds, oxidants, debris, or dust. Use pipes with the specified thickness. Note the following if reusing existing pipes that carried R22 refrigerant.

- Replace the existing flare nuts and flare the flared sections again.
- Do not use thin pipes.

Store the pipes to be used during installation indoors and keep both ends of the pipes sealed until just before brazing. (Leave elbow joints, etc. in their packaging.) If dust, debris, or moisture enters the refrigerant lines, oil deterioration or compressor breakdown may result.

Use ester oil, ether oil, alkylbenzene oil (small amount) as the refrigeration oil applied to the flared sections. If mineral oil is mixed in the refrigeration oil, oil deterioration may result.

Do not use refrigerant other than R410A refrigerant. If another refrigerant is used, the chlorine will cause the oil to deteriorate.

Use the following tools specifically designed for use with R410A refrigerant. The following tools are necessary to use R410A refrigerant. Contact your nearest dealer for any questions.

Tools (for R410A)	
Gauge manifold	Flare tool
Charge hose	Size adjustment gauge
Gas leak detector	Vacuum pump adapter
Torque wrench	Electronic refrigerant charging scale

Be sure to use the correct tools. If dust, debris, or moisture enters the refrigerant lines, refrigeration oil deterioration may result.

Do not use a charging cylinder. If a charging cylinder is used, the composition of the refrigerant will change and system efficiency will be reduced.



## CAUTIONS RELATED TO NEW REFRIGERANT

### Cautions for units utilizing refrigerant R410A

#### Use new refrigerant pipes.

If using the existing R22, be careful of the followings.

- For RP100, 125 and 140, be sure to perform replacement operation before test run.
- Change flare nut to the one provided with this product. Use a newly flared pipe.
- Avoid using thin pipes.

#### Make sure that the inside and outside of refrigerant piping is clean and it has no contaminants such as sulfur, oxides, dirt, shaving particles, etc, which are hazard to refrigerant cycle. In addition, use pipes with specified thickness.

Contamination inside refrigerant piping can cause deterioration of refrigerant oil etc.

#### Store the piping to be used indoors during installation, and both ends of the piping sealed until just before brazing. (Leave elbow joints, etc. in their packaging.)

If dirt, dust or moisture enters into refrigerant cycle, it can cause deterioration of refrigerant oil or malfunction of compressor.

#### The refrigerant oil applied to flare and flange connections must be ester oil, ether oil or alkylbenzene oil in a small amount.

If large amounts of mineral oil enters, it can cause deterioration of refrigerant oil etc.

#### Charge refrigerant from liquid phase of gas cylinder.

If the refrigerant is charged from gas phase, composition change may occur in refrigerant and the efficiency will be lowered.

#### Only use R410A refrigerant.

If other refrigerant (R22 etc.) is used, chlorine in refrigerant can cause deterioration of refrigerant oil etc.

#### Use a vacuum pump with a reverse flow check valve.

Vacuum pump oil may flow back into refrigerant cycle and that can cause deterioration of refrigerant oil etc.

#### Use the following tools specifically designed for use with R410A refrigerant.

The following tools are necessary to use R410A refrigerant.

Tools for R410A	
Gauge manifold	Flare tool
Charge hose	Size adjustment gauge
Gas leak detector	Vacuum pump adaptor
Torque wrench	Electronic refrigerant charging scale

#### Handle tools with care.

If dirt, dust or moisture enters into refrigerant cycle, that can cause deterioration of refrigerant oil or malfunction of compressor.

#### Do not use a charging cylinder.

If a charging cylinder is used, the composition of refrigerant will change and the efficiency will be lowered.

#### Ventilate the room if refrigerant leaks during operation. If refrigerant comes into contact with a flame, poisonous gases will be released.

#### Use the specified refrigerant only.

**Never use any refrigerant other than that specified.** Doing so may cause a burst, an explosion, or fire when the unit is being used, serviced, or disposed of. Correct refrigerant is specified in the manuals and on the spec labels provided with our products. We will not be held responsible for mechanical failure, system malfunction, unit breakdown or accidents caused by failure to follow the instructions.

## [1] Cautions for service

- (1) Perform service after recovering the refrigerant left in unit completely.
- (2) Do not release refrigerant in the air.
- (3) After completing service, charge the cycle with specified amount of refrigerant.
- (4) When performing service, install a filter drier simultaneously.  
Be sure to use a filter drier for new refrigerant.

## [2] Additional refrigerant charge

### When charging directly from cylinder

- Check that cylinder for R410A on the market is syphon type.
- Charging should be performed with the cylinder of syphon stood vertically. (Refrigerant is charged from liquid phase.)

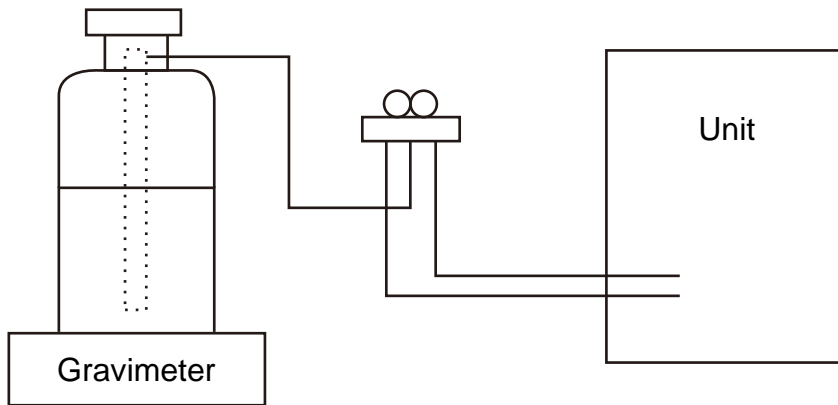

## [3] Service tools

Use the service tools below as exclusive tools for R410A refrigerant.

No.	Tool name	Specifications
①	Gauge manifold	<ul style="list-style-type: none"> <li>· Only for R410A</li> <li>· Use the existing fitting specifications. (UNF1/2)</li> <li>· Use high-tension side pressure of 5.3 MPa·G or over.</li> </ul>
②	Charge hose	<ul style="list-style-type: none"> <li>· Only for R410A</li> <li>· Use pressure performance of 5.09 MPa·G or over.</li> </ul>
③	Electronic scale	—
④	Gas leak detector	· Use the detector for R134a, R407C or R410A
⑤	Adaptor for reverse flow check	· Attach on vacuum pump.
⑥	Refrigerant charge base	—
⑦	Refrigerant cylinder	<ul style="list-style-type: none"> <li>· Only for R410A</li> <li>· Top of cylinder (Pink)</li> <li>· Cylinder with syphon</li> </ul>
⑧	Refrigerant recovery equipment	—

### Product specification

Model name	EHST20C-VM6HA	EHST20C-VM9HA	EHST20C-VM6A	EHST20C-VM9A	EHST20C-VM6SA	EHPT20X-VM2HA	EHPT20X-VM6HA	EHPT20X-VM9HA	EHPT20X-VM6A	EHPT20X-VM9A
Nominal domestic hot water volume	200L									
Overall unit dimensions	1600 x 595 x 680 mm (Height x Width x Depth)									
Weight (empty)	131 kg	131 kg	130 kg	130 kg	131 kg	119 kg	119 kg	119 kg	118 kg	118 kg
Weight (full)	346 kg	346 kg	345 kg	345 kg	346 kg	332 kg	332 kg	332 kg	331 kg	331 kg
Plate heat exchanger	✓	✓	✓	✓	✓	X	X	X	X	X
Unvented expansion vessel (Primary heating)	12 L									
Safety device	Nominal volume	1 bar								
	Charge pressure	1 - 80°C								
Water circuit (Primary)	Control thermistor	0.3 MPa (3 bar)								
	Pressure relief valve	Min flow 5.5 l/min								
Booster heater	Flow switch	80°C								
	Control thermistor	90°C								
Manual reset thermostat	Thermal Cut Off (for dry run prevention)	121°C								
	Control thermistor	40 - 70°C								
DHW tank	Temp & pressure relief valve	1.0 MPa (10 bar)	1.0 MPa (10 bar)	1.0 MPa (10 bar)	1.0 MPa (10 bar)	1.0 MPa (10 bar)	1.0 MPa (10 bar)	1.0 MPa (10 bar)	1.0 MPa (10 bar)	1.0 MPa (10 bar)
	Control thermistor	90°C/0.7 MPa (7 bar)	Grundfos UPSO 25-70 180							
Primary circuit circulating Pump	Water	28 mm compression primary circuit/ 22 mm compression DHW circuit/22 mm compression solar thermal (Ancillary heating) circuit								
	Refrigerant (R410A)	Liquid	9.52 mm	9.52 mm	9.52 mm	9.52 mm	9.52 mm	9.52 mm	9.52 mm	9.52 mm
Connections		Gas	15.88 mm	15.88 mm	15.88 mm	15.88 mm	15.88 mm	15.88 mm	15.88 mm	15.88 mm
	Operating ambient condition	0 (*1) - 35°C (≤ 80 % RH)								
Tank performance *2	Time to raise DHW tank temp 15 - 65°C	23 min								
	Time to reheat 70% of DHW tank to 65°C	20.5 min								
Electrical data	Control board	~N, 230 V, 50 Hz								
	Power supply (Phase, voltage, frequency)	10A								
Booster heater	Breaker (*when powered from independent source)									
	Power supply (Phase, voltage, frequency)	~N, 230 V, 50 Hz	3-, 400 V, 50 Hz	~N, 230 V, 50 Hz	~N, 230 V, 50 Hz	~N, 230 V, 50 Hz	~N, 230 V, 50 Hz	~N, 230 V, 50 Hz	~N, 230 V, 50 Hz	~N, 230 V, 50 Hz
Immersion heater *3	Capacity	2 kW+4 kW	3 kW+6 kW	2 kW+4 kW	3 kW+6 kW	2 kW	2 kW+4 kW	3 kW+6 kW	2 kW+4 kW	3 kW+6 kW
	Current	26 A	13 A	26 A	13 A	9 A	26 A	13 A	26 A	13 A
Solar (ancillary) connection	Breaker	32 A	16 A	32 A	16 A	16 A	32 A	16 A	32 A	16 A
	Power supply (Phase, voltage, frequency)	~N, 230 V, 50 Hz								
Capacity	Capacity	3 kW								
	Current	13 A								
Breaker	Breaker	16 A								
		X	X	X	X	✓	X	X	X	X

\*1 The environment must be frost-free.

\*2 Tested under BS7206 conditions .

\*3 Do not fit immersion heaters without thermal cutout.

#### Optional extras

- Wireless Remote Controller
- Wireless Receiver
- Immersion heater (1 Ph 3kW)
- EHPT Accessories for UK
- Remote sensor
- Joint pipe (15.88 → 12.7)
- Joint pipe (9.52 → 6.35)

- PAC-SE41TS-E
- PAC-SH50RJE
- PAC-SH30RJE

- PAR-WT40R-E
- PAR-WR41R-E
- PAC-IH03V-E
- PAC-WK01UK-E

# 4

## PART NAMES AND FUNCTIONS

### <EHST20C-\*M\*HA/\*M\*A> (Split model system)

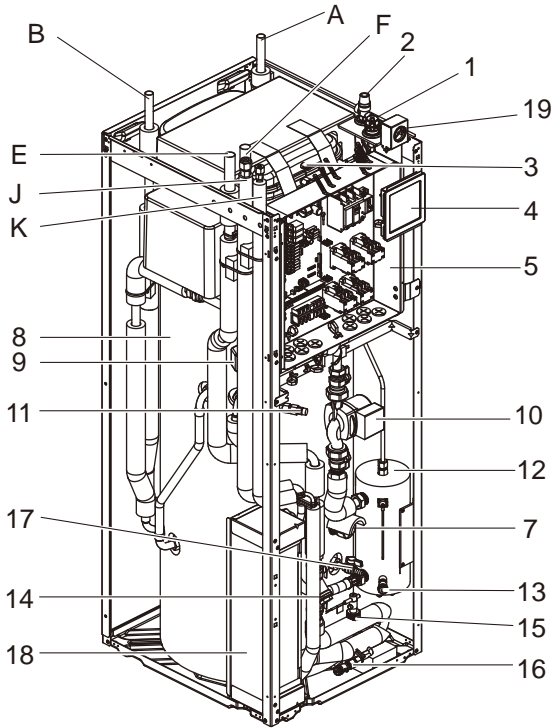

Figure 4-1

Number	Component
1	Automatic air vent
2	Pressure relief valve
3	Expansion vessel
4	Main controller
5	Control and electrical box
7	Immersion heater (Only for EHST20C-*M*HA)
8	DHW tank
9	3-way valve
10	Water circulation pump
11	Manual air vent
12	Booster heater
13	Drain cock (Booster heater)
14	Strainer valve
15	Flow switch
16	Drain cock (Primary circuit)
17	Drain cock (DHW tank)
18	Plate heat exchanger
19	Manometer
A	DHW outlet
B	Cold water inlet
E	Inlet from space heating
F	Outlet to space heating
J	Refrigerant (Gas)
K	Refrigerant (Liquid)

### <EHST20C-VM6SA> (Solar split model system)

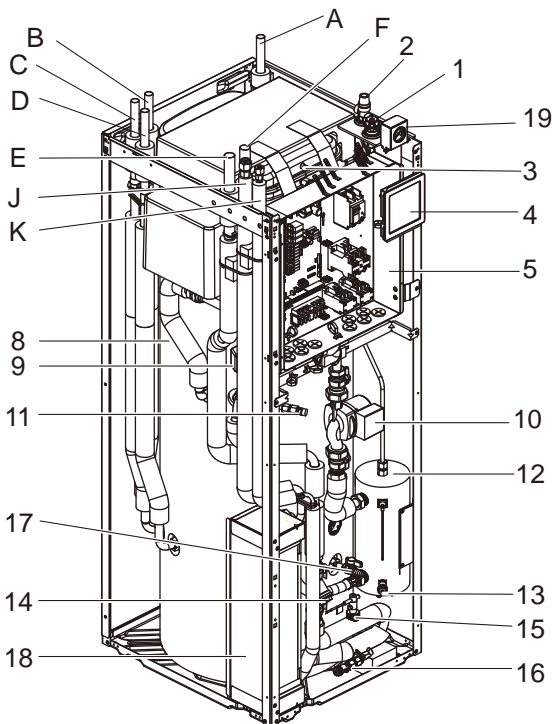

Figure 4-2

Number	Component
1	Automatic air vent
2	Pressure relief valve
3	Expansion vessel
4	Main controller
5	Control and electrical box
8	DHW tank
9	3-way valve
10	Water circulation pump
11	Manual air vent
12	Booster heater
13	Drain cock (Booster heater)
14	Strainer valve
15	Flow switch
16	Drain cock (Primary circuit)
17	Drain cock (DHW tank)
18	Plate heat exchanger
19	Manometer
A	DHW outlet
B	Cold water inlet
C	Outlet to solar
D	Inlet from solar
E	Inlet from space heating
F	Outlet to space heating
J	Refrigerant (Gas)
K	Refrigerant (Liquid)

**<EHPT20X-VM2HA> (UK Packaged model system)**

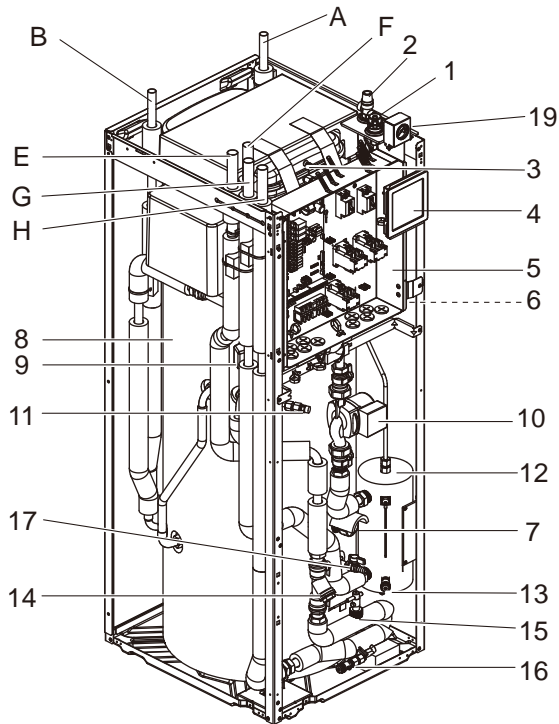

Figure 4-3

Number	Component
1	Automatic air vent
2	Pressure relief valve
3	Expansion vessel
4	Main controller
5	Control and electrical box
6	Temperature and pressure relief valve (not visible)
7	Immersion heater
8	DHW tank
9	3-way valve
10	Water circulation pump
11	Manual air vent
12	Booster heater
13	Drain cock (Booster heater)
14	Strainer valve
15	Flow switch
16	Drain cock (Primary circuit)
17	Drain cock (DHW tank)
19	Manometer
A	DHW outlet
B	Cold water inlet
E	Inlet from space heating
F	Outlet to space heating
G	Inlet from heat pump
H	Outlet to heat pump

**<EHPT20X-\*M\*HA/\*M\*A (except EHPT20X-VM2HA)> (Packaged model system)**

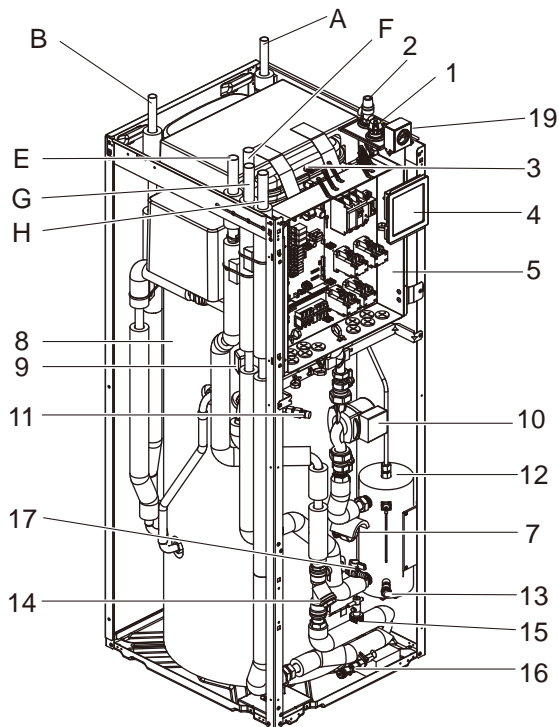

Figure 4-4

Number	Component
1	Automatic air vent
2	Pressure relief valve
3	Expansion vessel
4	Main controller
5	Control and electrical box
7	Immersion heater (Only for EHPT20X-*M*HA)
8	DHW tank
9	3-way valve
10	Water circulation pump
11	Manual air vent
12	Booster heater
13	Drain cock (Booster heater)
14	Strainer valve
15	Flow switch
16	Drain cock (Primary circuit)
17	Drain cock (DHW tank)
19	Manometer
A	DHW outlet
B	Cold water inlet
E	Inlet from space heating
F	Outlet to space heating
G	Inlet from heat pump
H	Outlet to heat pump

# 5

# OUTLINES AND DIMENSIONS

## 5-1. Technical Drawings

(Unit: mm)

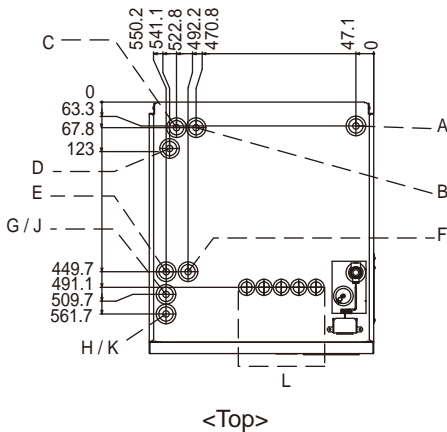
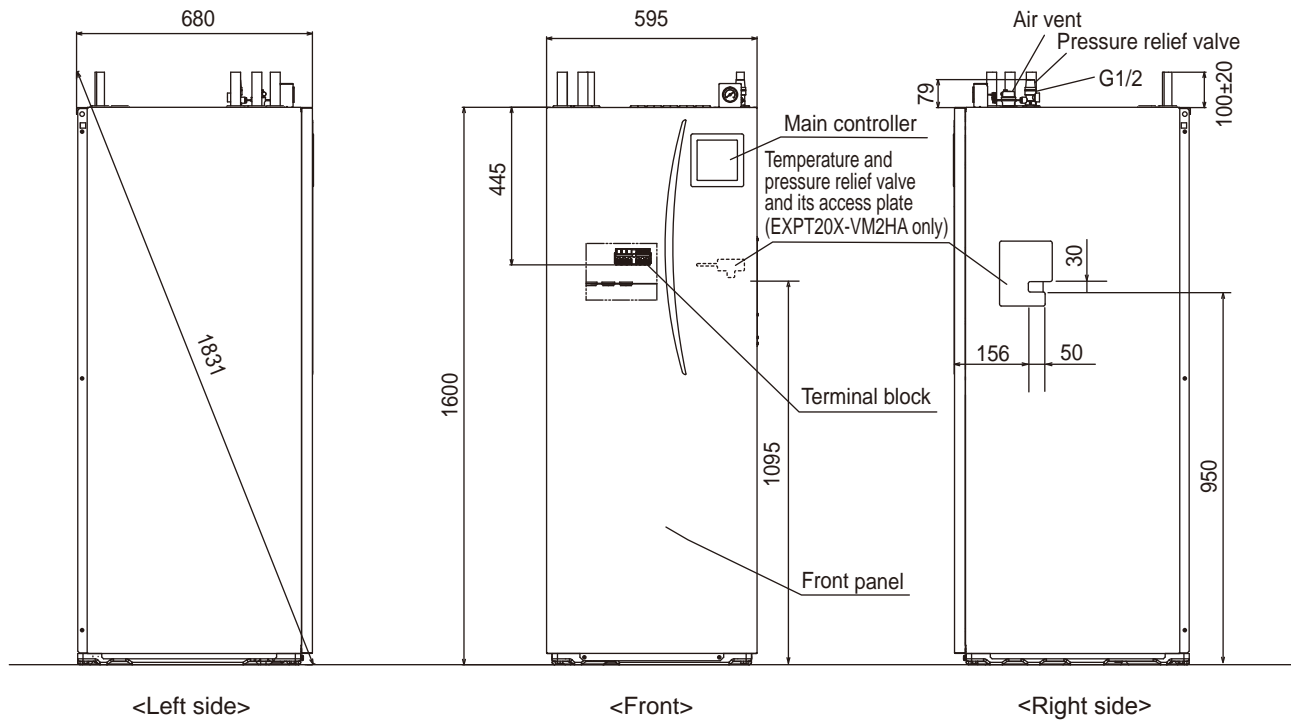

Letter	Pipe description	Connection size/type
A	DHW outlet connection	22 mm/Compression
B	Cold water inlet connection	22 mm/Compression
C/D	Solar (ancillary heat source) connection	22 mm/Compression
E	Space heating return connection	28 mm/Compression
F	Space heating flow connection	28 mm/Compression
G	Flow from heat pump connection (No plate heat exchanger)	28 mm/Compression
H	Return to heat pump connection (No plate heat exchanger)	28 mm/Compression
J	Refrigerant (GAS) (With plate heat exchanger)	15.88 mm/Flare
K	Refrigerant (LIQUID) (With plate heat exchanger)	9.52 mm/Flare
L	Electrical cable inlets	— * The leftmost hole is for wireless receiver (option) (PAR-WR41R-E)

## 5-2. Service access diagrams

Service access	
Parameter	Dimension (mm)
a	300
b	150
c (distance behind unit not visible in the figure on the right)	10
d	500

Sufficient space MUST be left for the provision of discharge pipework as detailed in National and Local building regulations.

The cylinder unit must be located indoors and in a frost-free environment, for example in a utility room, to minimise heat loss from stored water.

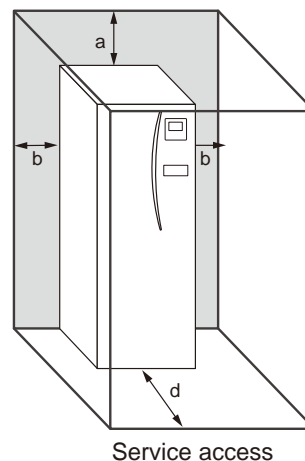

6-1. EHST20C-VM6HA

Table 1 External input

Name	Terminal block	Connector	Item	OFF (Open)	ON (Short)
IN1	TBI.2 5-6	—	Room thermostat input	Refer to SW2-1	—
IN2	TBI.2 7-8	CN2F	Flow switch input	Refer to SW2-2	—
IN3	—	—	—	—	—
IN4	TBI.2 13-14	—	Heat source OFF input	Normal	Heat source OFF
IN5	TBI.3 7-8	—	Outdoor thermostat input	Standard operation	Heater operation
IN6	—	—	—	—	—
IN7	—	—	—	—	—
IN8	—	—	—	— </tr	

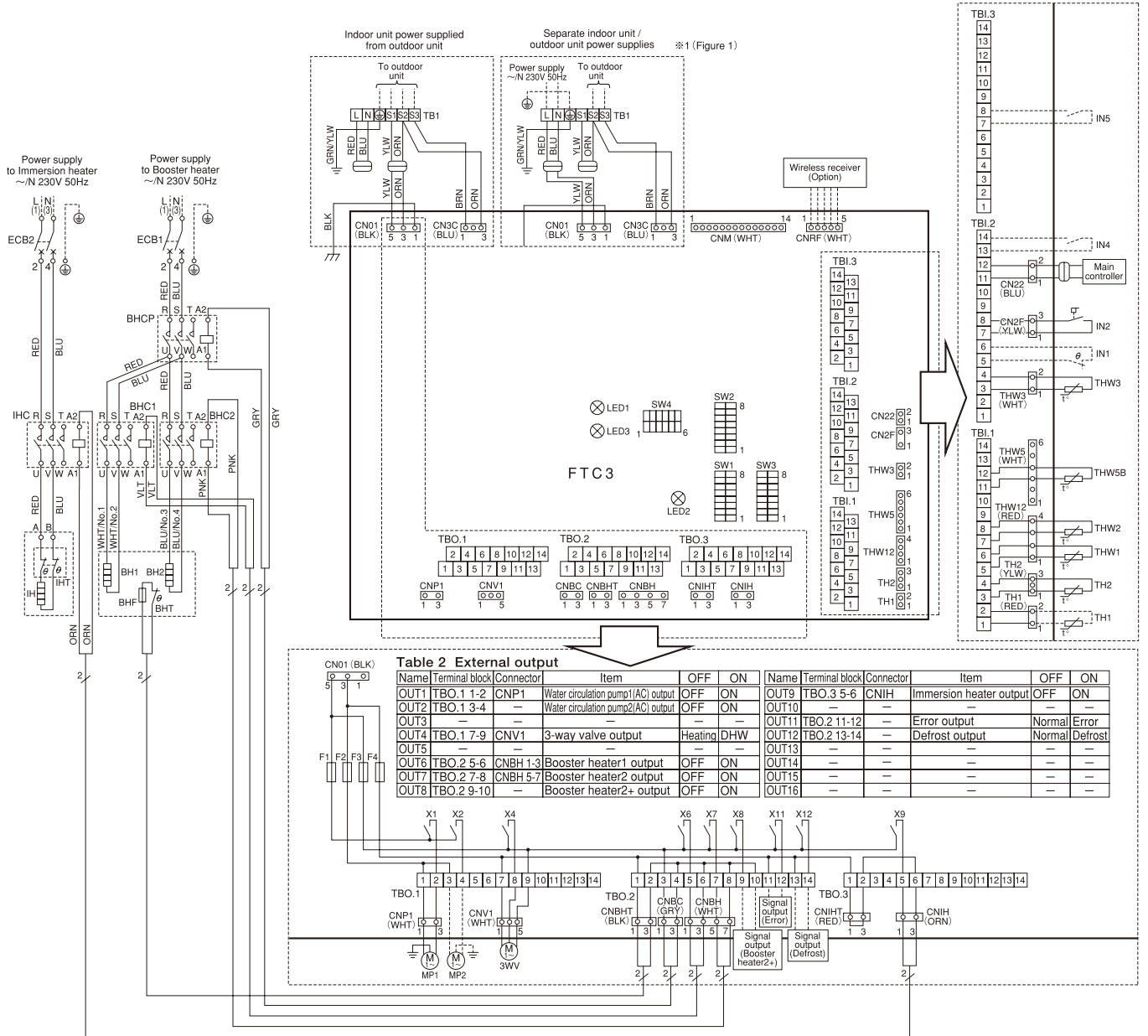

Table 2 External output

Name	Terminal block	Connector	Item	OFF	ON	Name	Terminal block	Connector	Item	OFF	ON
OUT1	TBO.1 1-2	CNP1	Water circulation pump1(AC) output	OFF	ON	OUT9	TBO.3 5-6	CNIH	Immersion heater output	OFF	ON
OUT2	TBO.1 3-4	—	Water circulation pump2(AC) output	OFF	ON	OUT10	—	—	—	—	—
OUT3	—	—	—	—	—	OUT11	TBO.2 11-12	—	Error output	Normal	Error
OUT4	TBO.1 7-9	CNV1	3-way valve output	Heating	DHW	OUT12	TBO.2 13-14	—	Defrost output	Normal	Defrost
OUT5	—	—	—	—	—	OUT13	—	—	—	—	—
OUT6	TBO.2 5-6	CNBH 1-3	Booster heater1 output	OFF	ON	OUT14	—	—	—	—	—
OUT7	TBO.2 7-8	CNBH 5-7	Booster heater2 output	OFF	ON	OUT15	—	—	—	—	—
OUT8	TBO.2 9-10	—	Booster heater2+ output	OFF	ON	OUT16	—	—	—	—	—

Symbol	Name	Remark
TB1	Terminal block (Power supply, Outdoor unit)	
ECB1	Earth leakage circuit breaker for booster heater	
ECB2	Earth leakage circuit breaker for immersion heater	
MP1	Water circulation pump1(AC)	OUT1(CNP1)
MP2	Water circulation pump2(AC)(Locally supplied)	OUT2
3WV	3-way valve	OUT4(CNV1)
BHT	Thermostat for booster heater	
BHF	Thermal fuse for booster heater	
BH1	Booster heater1	
BH2	Booster heater2	
BHC1	Contactor for booster heater1	
BHC2	Contactor for booster heater2	
BHCP	Contactor for booster heater protection	
IHT	Thermostat (Fixed temperature) for immersion heater	
IH	Immersion heater	
IHC	Contactor for immersion heater	

Symbol	Name
TH1	Thermistor(Room temp)(Option)
TH2	Thermistor(Ref. liquid temp)
THW1	Thermistor(Flow water temp)
THW2	Thermistor(Return water temp)
THW5B	Thermistor(Tank water temp B)
THW3	Thermistor(Booster heater temp)
IN1	Room thermostat(Locally supplied)
IN2	Flow switch
IN4	Heat source OFF signal(Locally supplied)
IN5	Outdoor thermostat(Locally supplied)
FLOW TEMP. CONTROLLER(FTC3)	
TBO.1~3	Terminal block(External output)
TBI.1~3	Terminal block(External input contact signal, Thermistor)
F1~4	Fuse(T6.3AL250V)
SW1~4	Switch * See Chapter 6-10.
CNM	Connector(A-Control service tool)
X1.2.4~13	Relay
LED1	Power supply(FTC3)
LED2	Power supply(Main controller)
LED3	Communication(FTC3-Outdoor unit)

- Symbols used in wiring diagram are, : connector, : terminal block.
- Indoor unit and outdoor unit connecting wires have polarities, make sure to match terminal numbers (S1,S2, S3) for correct wirings.
- Since the outdoor unit side electric wiring may change, be sure to check the outdoor unit electric wiring diagram for servicing.
- This diagram shows the wiring of indoor unit and outdoor unit connecting wires (specification of 230V), adopting superimposed system of power and signal.  
※1: When work to supply power separately to indoor unit and outdoor unit was applied, refer to Figure 1.
- Do not connect to the terminals that are indicated as "-" in the "Terminal block" field of Table 2.
- Do not fit booster heater 2+ (locally supplied) without thermal cutout.



## 6-2. EHST20C-YM9HA

**Table 1 External input**

Name	Terminal block	Connector	Item	OFF (Open)	ON (Short)
IN1	TBI.2 5-6	—	Room thermostat input	Refer to SW2-1	—
IN2	TBI.2 7-8	CN2F	Flow switch input	Refer to SW2-2	—
IN3	—	—	—	—	—
IN4	TBI.2 13-14	—	Heat source OFF input	Normal	Heat source OFF
IN5	TBI.3 7-8	—	Outdoor thermostat input	Standard operation	Heater operation
IN6	—	—	—	—	—
IN7	—	—	—	—	—
IN8	—	—	—	— </tr	

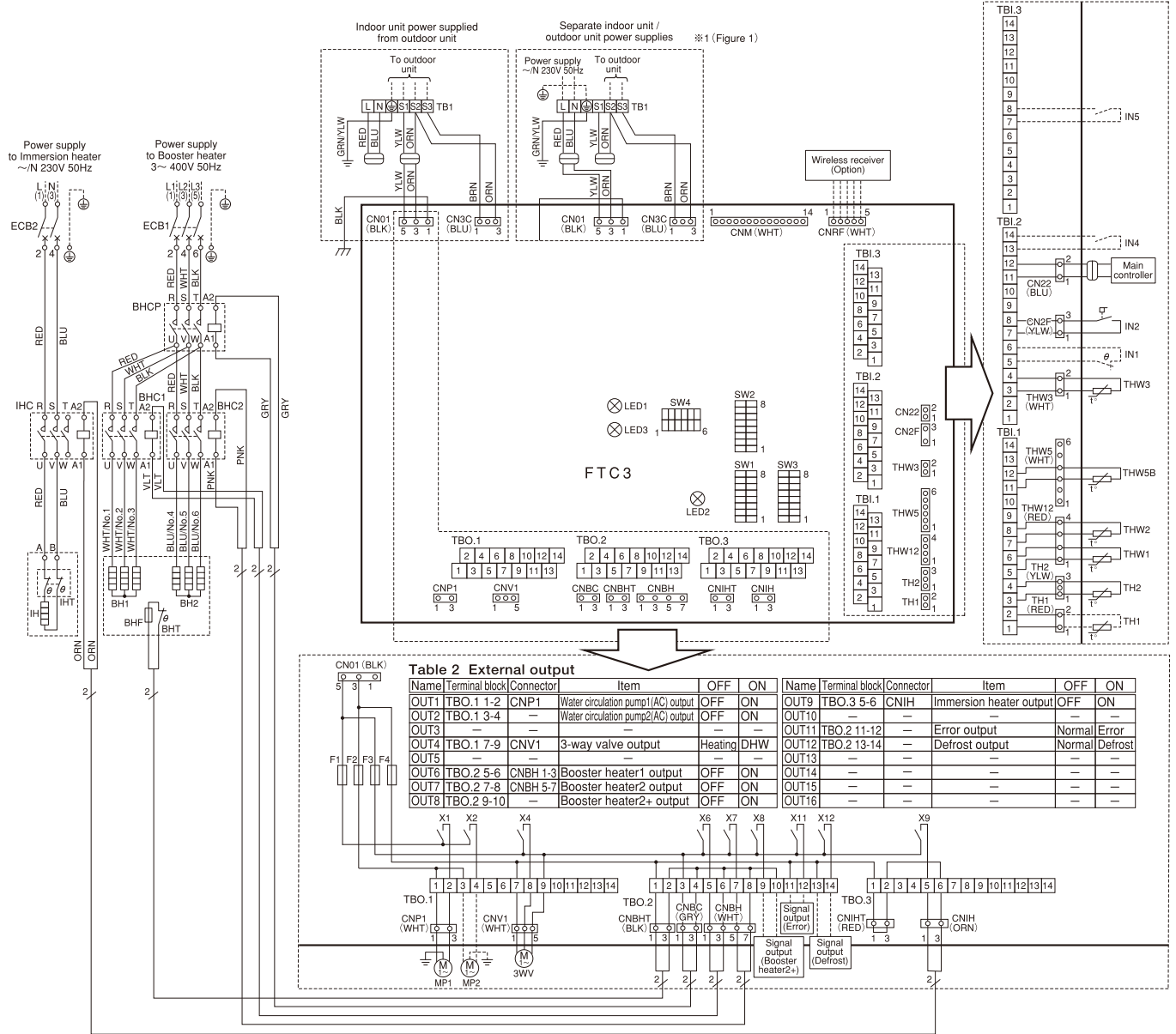

**Table 2 External output**

Name	Terminal block	Connector	Item	OFF	ON	Name	Terminal block	Connector	Item	OFF	ON
OUT1	TBO.1 1-2	CNP1	Water circulation pump1(AC) output	OFF	ON	OUT9	TBO.3 5-6	CNHT	Immersion heater output	OFF	ON
OUT2	TBO.1 3-4	—	Water circulation pump2(AC) output	OFF	ON	OUT10	—	—	—	—	—
OUT3	—	—	—	—	—	OUT11	TBO.2 11-12	—	Error output	Normal	Error
OUT4	TBO.1 7-9	CNV1	3-way valve output	Heating	DHW	OUT12	TBO.2 13-14	—	Defrost output	Normal	Defrost
OUT5	—	—	—	—	—	OUT13	—	—	—	—	—
OUT6	TBO.2 5-6	CNBH 1-3	Booster heater1 output	OFF	ON	OUT14	—	—	—	—	—
OUT7	TBO.2 7-8	CNBH 5-7	Booster heater2 output	OFF	ON	OUT15	—	—	—	—	—
OUT8	TBO.2 9-10	—	Booster heater2+ output	OFF	ON	OUT16	—	—	—	—	—

Symbol	Name	Remark
TB1	Terminal block (Power supply, Outdoor unit)	
ECB1	Earth leakage circuit breaker for booster heater	
ECB2	Earth leakage circuit breaker for immersion heater	
MP1	Water circulation pump1(AC)	OUT1(CNP1)
MP2	Water circulation pump2(AC)(Locally supplied)	OUT2
3WV	3-way valve	OUT4(CNV1)
BHT	Thermostat for booster heater	
BHF	Thermal fuse for booster heater	
BH1	Booster heater1	
BH2	Booster heater2	
BHC1	Contactor for booster heater1	
BHC2	Contactor for booster heater2	
BHCP	Contactor for booster heater protection	
IHT	Thermostat (Fixed temperature) for immersion heater	
IH	Immersion heater	
IHC	Contactor for immersion heater	

Symbol	Name
TH1	Thermistor(Room temp)(Option)
TH2	Thermistor(Ref. liquid temp)
THW1	Thermistor(Flow water temp)
THW2	Thermistor(Return water temp)
THW5B	Thermistor(Tank water temp B)
THW3	Thermistor(Booster heater temp)
IN1	Room thermostat(Locally supplied)
IN2	Flow switch
IN4	Heat source OFF signal(Locally supplied)
IN5	Outdoor thermostat(Locally supplied)
FLOW TEMP. CONTROLLER(FTC3)	
TBO.1~3	Terminal block(External output)
TBI.1~3	Terminal block(External input contact signal, Thermistor)
F1~4	Fuse(T6.3A/250V)
SW1~4	Switch * See Chapter 6-10.
CNM	Connector(A-Control service tool)
X1 2.4~13	Relay
LED1	Power supply(FTC3)
LED2	Power supply(Main controller)
LED3	Communication(FTC3-Outdoor unit)

- Symbols used in wiring diagram are.
  - : connector, □: terminal block.
- Indoor unit and outdoor unit connecting wires have polarities, make sure to match terminal numbers (S1, S2, S3) for correct wirings.
- Since the outdoor unit side electric wiring may change, be sure to check the outdoor unit electric wiring diagram for servicing.
- This diagram shows the wiring of indoor unit and outdoor unit connecting wires (specification of 230V), adopting superimposed system of power and signal.
  - ※1: When work to supply power separately to indoor unit and outdoor unit was applied, refer to Figure 1.
- Do not connect to the terminals that are indicated as "-" in the "Terminal block" field of Table 2.
- Do not fit booster heater 2+ (locally supplied) without thermal cutout.



### 6-3. EHST20C-VM6A EHST20C-VM6SA

**Table 1 External input**

Name	Terminal block	Connector	Item	OFF (Open)	ON (Short)
IN1	TBI.2 5-6	—	Room thermostat input	—	Refer to SW2-1
IN2	TBI.2 7-8	CN2F	Flow switch input	—	Refer to SW2-2
IN3	—	—	—	—	—
IN4	TBI.2 13-14	—	Heat source OFF input	Normal	Heat source OFF
IN5	TBI.3 7-8	—	Outdoor thermostat input	Standard operation	Heater operation
IN6	—	—	—	—	—
IN7	—	—	—	—	—
IN8	—	—	—	—	—

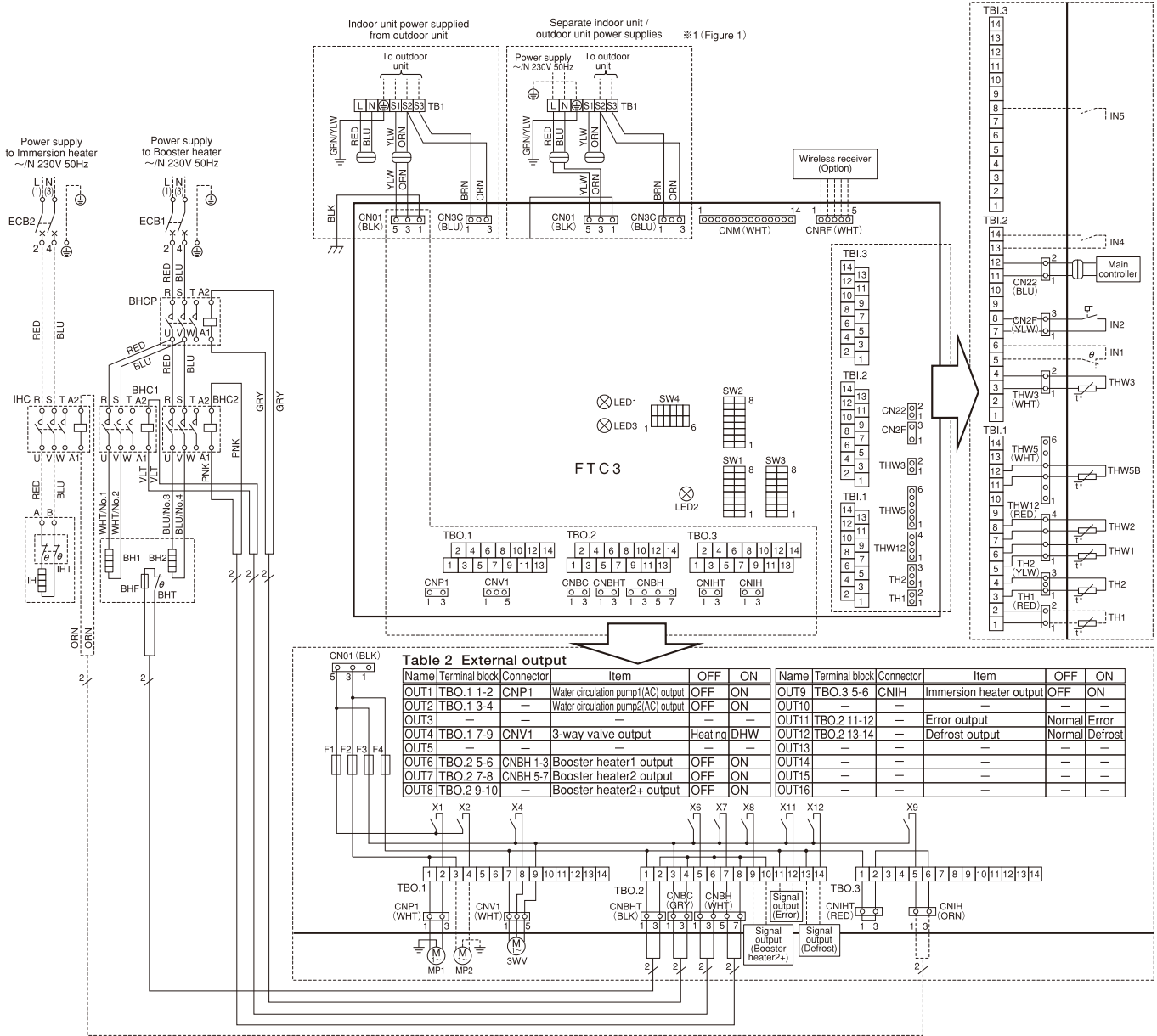

**Table 2 External output**

Name	Terminal block	Connector	Item	OFF	ON	Name	Terminal block	Connector	Item	OFF	ON
OUT1	TBO.1 1-2	CNP1	Water circulation pump1(AC) output	OFF	ON	OUT9	TBO.3 5-6	CNIH	Immersion heater output	OFF	ON
OUT2	TBO.1 3-4	—	Water circulation pump2(AC) output	OFF	ON	OUT10	—	—	—	—	—
OUT3	—	—	—	—	—	OUT11	TBO.2 11-12	—	Error output	Normal	Error
OUT4	TBO.1 7-9	CNV1	3-way valve output	Heating	DHW	OUT12	TBO.2 13-14	—	Defrost output	Normal	Defrost
OUT5	—	—	—	—	—	OUT13	—	—	—	—	—
OUT6	TBO.2 5-6	CNBH 1-3	Booster heater1 output	OFF	ON	OUT14	—	—	—	—	—
OUT7	TBO.2 7-8	CNBH 5-7	Booster heater2 output	OFF	ON	OUT15	—	—	—	—	—
OUT8	TBO.2 9-10	—	Booster heater2+ output	OFF	ON	OUT16	—	—	—	—	—

Symbol	Name	Remark
TB1	Terminal block (Power supply, Outdoor unit)	
ECB1	Earth leakage circuit breaker for booster heater	
ECB2	Earth leakage circuit breaker for immersion heater (Option)	
MP1	Water circulation pump1(AC)	OUT1(CNP1)
MP2	Water circulation pump2(AC)(Locally supplied)	OUT2
3WV	3-way valve	OUT4(CNV1)
BHT	Thermostat for booster heater	
BHF	Thermal fuse for booster heater	
BH1	Booster heater1	
BH2	Booster heater2	
BHC1	Contactor for booster heater1	
BHC2	Contactor for booster heater2	
BHCP	Contactor for booster heater protection	
IHT	Thermostat (Fixed temperature) for immersion heater (Option)	
IH	Immersion heater(Option)	
IHC	Contactor for immersion heater(Option)	

Symbol	Name
TH1	Thermistor(Room temp)(Option)
TH2	Thermistor(Ref. liquid temp)
THW1	Thermistor(Flow water temp)
THW2	Thermistor(Return water temp)
THW5B	Thermistor(Tank water temp B)
THW3	Thermistor(Booster heater temp)
IN1	Room thermostat(Locally supplied)
IN2	Flow switch
IN4	Heat source OFF signal(Locally supplied)
IN5	Outdoor thermostat(Locally supplied)
FLOW TEMP. CONTROLLER(FTC3)	
TBO.1~3	Terminal block(External output)
TBI.1~3	Terminal block(External input contact signal, Thermistor)
F1~4	Fuse(T6.3A/250V)
SW1~4	Switch * See Chapter 6-10.
CNM	Connector(A-Control service tool)
X1.2.4~13	Relay
LED1	Power supply(FTC3)
LED2	Power supply(Main controller)
LED3	Communication(FTC3-Outdoor unit)

- Symbols used in wiring diagram are, : connector, : terminal block.
- Indoor unit and outdoor unit connecting wires have polarities, make sure to match terminal numbers (S1, S2, S3) for correct wirings.
- Since the outdoor unit side electric wiring may change, be sure to check the outdoor unit electric wiring diagram for servicing.
- This diagram shows the wiring of indoor unit and outdoor unit connecting wires (specification of 230V), adopting superimposed system of power and signal.  
※1: When work to supply power separately to indoor unit and outdoor unit was applied, refer to Figure 1.
- Do not connect to the terminals that are indicated as "-" in the "Terminal block" field of Table 2.
- Do not fit booster heater 2+ (locally supplied) without thermal cutout.

## 6-4. EHST20C-YM9A

**Table 1 External input**

Name	Terminal block	Connector	Item	OFF (Open)	ON (Short)
IN1	TBI.2 5-6	—	Room thermostat input	—	Refer to SW2-1
IN2	TBI.2 7-8	CN2F	Flow switch input	—	Refer to SW2-2
IN3	—	—	—	—	—
IN4	TBI.2 13-14	—	Heat source OFF input	Normal	Heat source OFF
IN5	TBI.3 7-8	—	Outdoor thermostat input	Standard operation	Heater operation
IN6	—	—	—	—	—
IN7	—	—	—	—	—
IN8	—	—	—	—	—

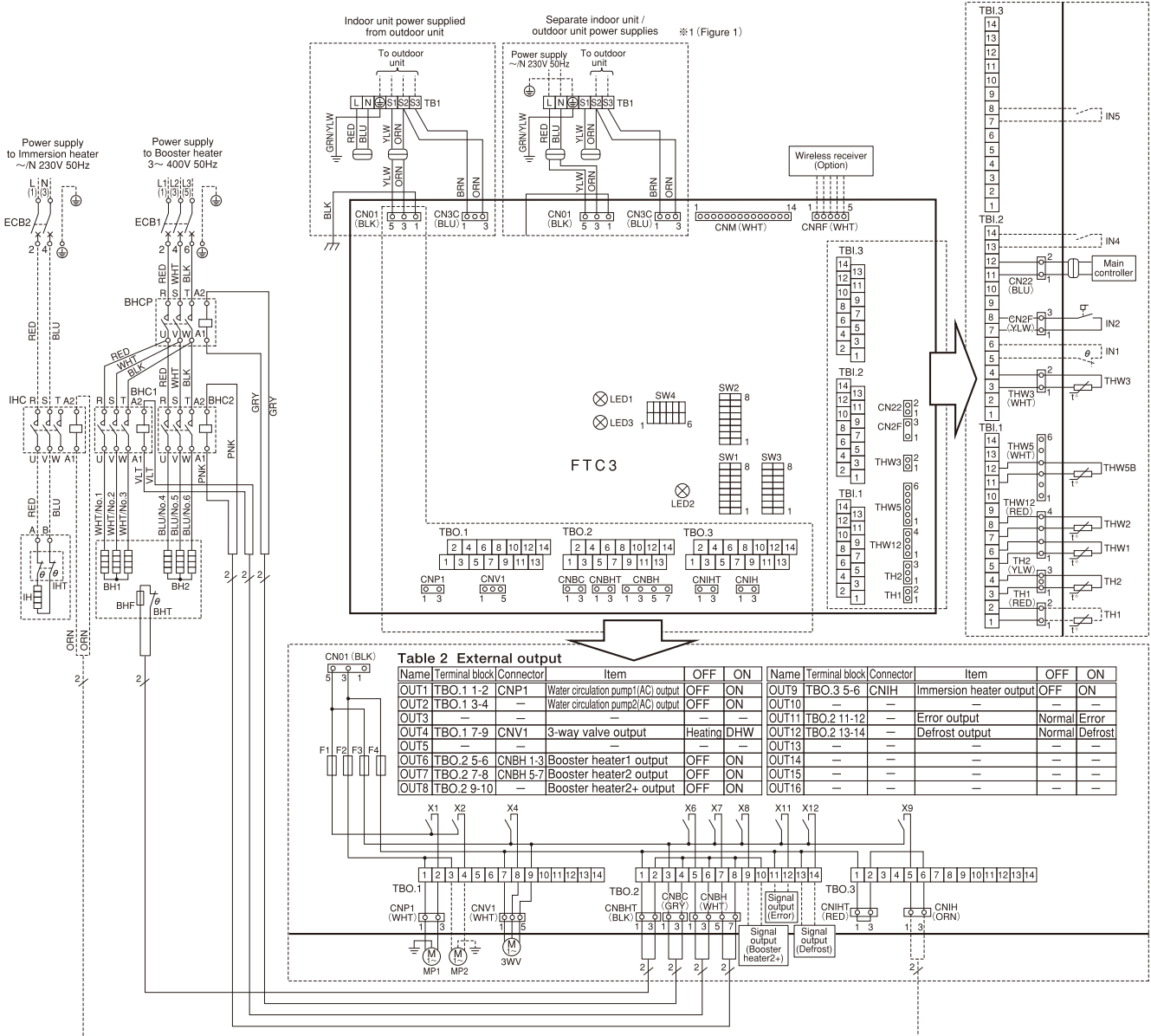

Symbol	Name	Remark
TB1	Terminal block (Power supply, Outdoor unit)	
ECB1	Earth leakage circuit breaker for booster heater	
ECB2	Earth leakage circuit breaker for immersion heater (Option)	
MP1	Water circulation pump1(AC)	OUT1(CNP1)
MP2	Water circulation pump2(AC)(Locally supplied)	OUT2
3WV	3-way valve	OUT4(CNV1)
BHT	Thermostat for booster heater	
BHF	Thermal fuse for booster heater	
BH1	Booster heater1	
BH2	Booster heater2	
BHC1	Contactor for booster heater1	
BHC2	Contactor for booster heater2	
BHCP	Contactor for booster heater protection	
IHT	Thermostat (Fixed temperature) for immersion heater (Option)	
IHT	Immersion heater(Option)	
IHC	Contactor for immersion heater(Option)	

Symbol	Name
TH1	Thermistor(Room temp)(Option)
TH2	Thermistor(Ref. liquid temp)
THW1	Thermistor(Flow water temp)
THW2	Thermistor(Return water temp)
THW5B	Thermistor(Tank water temp B)
THW3	Thermistor(Booster heater temp)
IN1	Room thermostat(Locally supplied)
IN2	Flow switch
IN4	Heat source OFF signal(Locally supplied)
IN5	Outdoor thermostat(Locally supplied)
FLOW TEMP. CONTROLLER(FTC3)	
TBO.1~3	Terminal block(External output)
TBI.1~3	Terminal block(External input contact signal, Thermistor)
F1~4	Fuse(T6.3AL250V)
SW1~4	Switch * See Chapter 6-10.
CNM	Connector(A-Control service tool)
X1.2.4~13	Relay
LED1	Power supply(FTC3)
LED2	Power supply(Main controller)
LED3	Communication(FTC3-Outdoor unit)

- Symbols used in wiring diagram are, : connector, : terminal block.
- Indoor unit and outdoor unit connecting wires have polarities, make sure to match terminal numbers (S1, S2, S3) for correct wirings.
- Since the outdoor unit side electric wiring may change, be sure to check the outdoor unit electric wiring diagram for servicing.
- This diagram shows the wiring of indoor unit and outdoor unit connecting wires (specification of 230V), adopting superimposed system of power and signal.  
※1: When work to supply power separately to indoor unit and outdoor unit was applied, refer to Figure 1.
- Do not connect to the terminals that are indicated as "—" in the "Terminal block" field of Table 2.
- Do not fit booster heater 2+ (locally supplied) without thermal cutout.

## 6-5. EHPT20X-VM2HA

**Table 1 External input**

Name	Terminal block	Connector	Item	OFF (Open)	ON (Short)
IN1	TBI.2 5-6	—	Room thermostat input	Refer to SW2-1	—
IN2	TBI.2 7-8	CN2F	Flow switch input	Refer to SW2-2	—
IN3	—	—	—	—	—
IN4	TBI.2 13-14	—	Heat source OFF input	Normal	Heat source OFF
IN5	TBI.3 7-8	—	Outdoor thermostat input	Standard operation	Heater operation
IN6	—	—	—	—	—
IN7	—	—	—	—	—
IN8	—	—	—	— </tr	

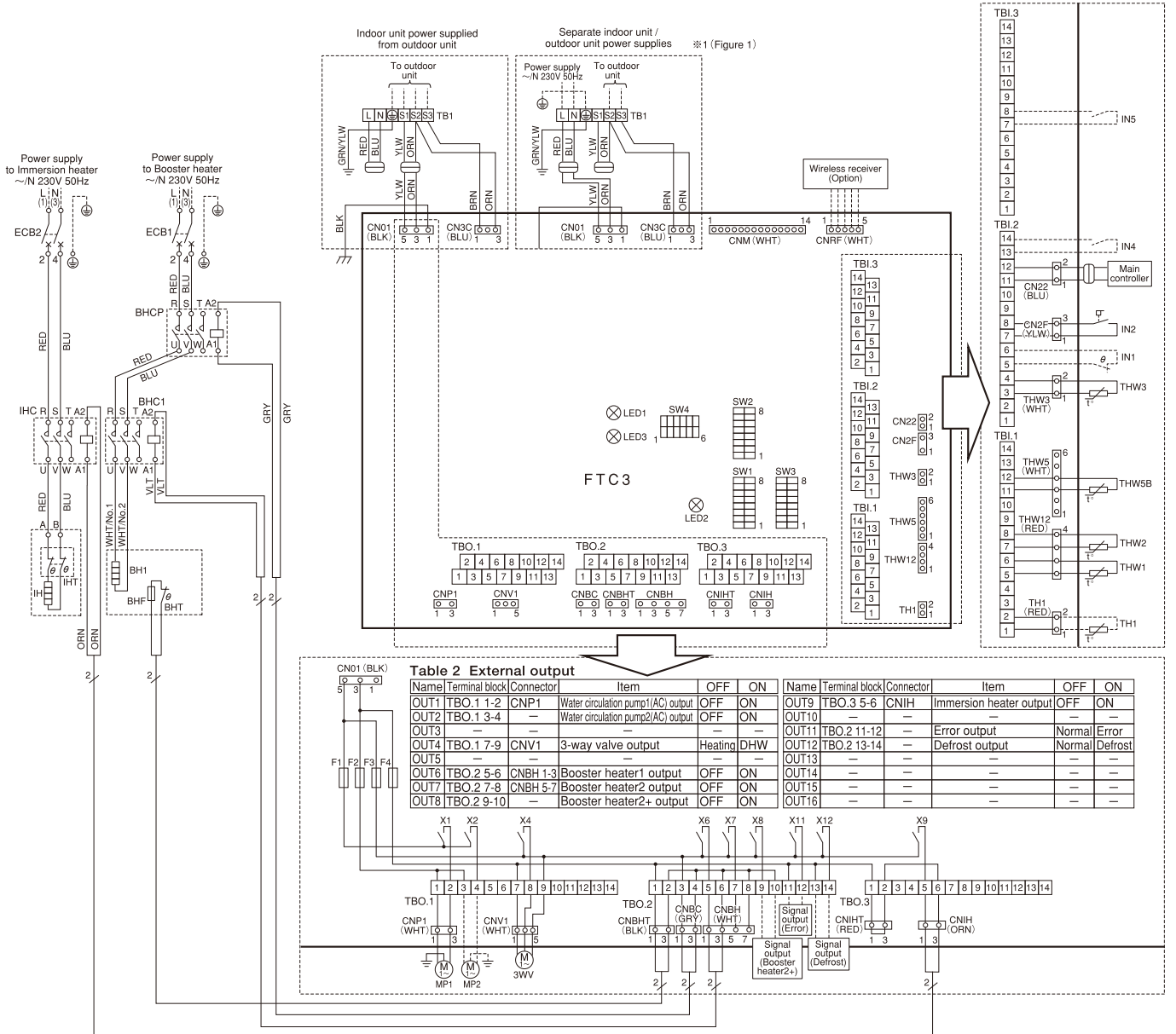

**Table 2 External output**

Name	Terminal block	Connector	Item	OFF	ON	Name	Terminal block	Connector	Item	OFF	ON
OUT1	TBO.1 1-2	CNP1	Water circulation pump1(AC) output	OFF	ON	OUT9	TBO.3 5-6	CNIH	Immersion heater output	OFF	ON
OUT2	TBO.1 3-4	—	Water circulation pump2(AC) output	OFF	ON	OUT10	—	—	—	—	—
OUT3	—	—	—	—	—	OUT11	TBO.2 11-12	—	Error output	Normal	Error
OUT4	TBO.1 7-9	CNV1	3-way valve output	Heating	DHW	OUT12	TBO.2 13-14	—	Defrost output	Normal	Defrost
OUT5	—	—	—	—	—	OUT13	—	—	—	—	—
OUT6	TBO.2 5-6	CNBH 1-3	Booster heater1 output	OFF	ON	OUT14	—	—	—	—	—
OUT7	TBO.2 7-8	CNBH 5-7	Booster heater2 output	OFF	ON	OUT15	—	—	—	—	—
OUT8	TBO.2 9-10	—	Booster heater2+ output	OFF	ON	OUT16	—	—	—	—	—

Symbol	Name	Remark
TB1	Terminal block (Power supply, Outdoor unit)	
ECB1	Earth leakage circuit breaker for booster heater	
ECB2	Earth leakage circuit breaker for immersion heater	
MP1	Water circulation pump1(AC)	OUT1(CNP1)
MP2	Water circulation pump2(AC)(Locally supplied)	OUT2
3WV	3-way valve	OUT4(CNV1)
BHT	Thermostat for booster heater	
BHF	Thermal fuse for booster heater	
BH1	Booster heater1	
BHC1	Contactor for booster heater1	
BHCP	Contactor for booster heater protection	
IHT	Thermostat (Fixed temperature) for immersion heater	
IH	Immersion heater	
IHC	Contactor for immersion heater	

Symbol	Name
TH1	Thermistor(Room temp)(Option)
THW1	Thermistor(Flow water temp)
THW2	Thermistor(Return water temp)
THW5B	Thermistor(Tank water temp B)
THW3	Thermistor(Booster heater temp)
IN1	Room thermostat(Locally supplied)
IN2	Flow switch
IN4	Heat source OFF signal(Locally supplied)
IN5	Outdoor thermostat(Locally supplied)
FLOW TEMP. CONTROLLER(FTC3)	
TBO.1~3	Terminal block(External output)
TBI.1~3	Terminal block(External input/contact signal, Thermistor)
F1~4	Fuse(T6.3AL250V)
SW1~4	Switch * See Chapter 6-10.
CNM	Connector(A-Control service tool)
X1.2.4~13	Relay
LED1	Power supply(FTC3)
LED2	Power supply(Main controller)
LED3	Communication(FTC3-Outdoor unit)

- Symbols used in wiring diagram are. [ ] : connector, [ ] : terminal block.
- Indoor unit and outdoor unit connecting wires have polarities, make sure to match terminal numbers (S1, S2, S3) for correct wirings.
- Since the outdoor unit side electric wiring may change, be sure to check the outdoor unit electric wiring diagram for servicing.
- This diagram shows the wiring of indoor unit and outdoor unit connecting wires (specification of 230V), adopting superimposed system of power and signal.  
※1: When work to supply power separately to indoor unit and outdoor unit was applied, refer to Figure 1.
- Do not connect to the terminals that are indicated as "-" in the "Terminal block" field of Table 2.
- Do not fit booster heater 2+ (locally supplied) without thermal cutout.

## 6-6. EHPT20X-VM6HA

**Table 1 External input**

Name	Terminal block	Connector	Item	OFF (Open)	ON (Short)
IN1	TBI.2 5-6	—	Room thermostat input	Refer to SW2-1	—
IN2	TBI.2 7-8	CN2F	Flow switch input	Refer to SW2-2	—
IN3	—	—	—	—	—
IN4	TBI.2 13-14	—	Heat source OFF input	Normal	Heat source OFF
IN5	TBI.3 7-8	—	Outdoor thermostat input	Standard operation	Heater operation
IN6	—	—	—	—	—
IN7	—	—	—	—	—
IN8	—	—	—	—	—

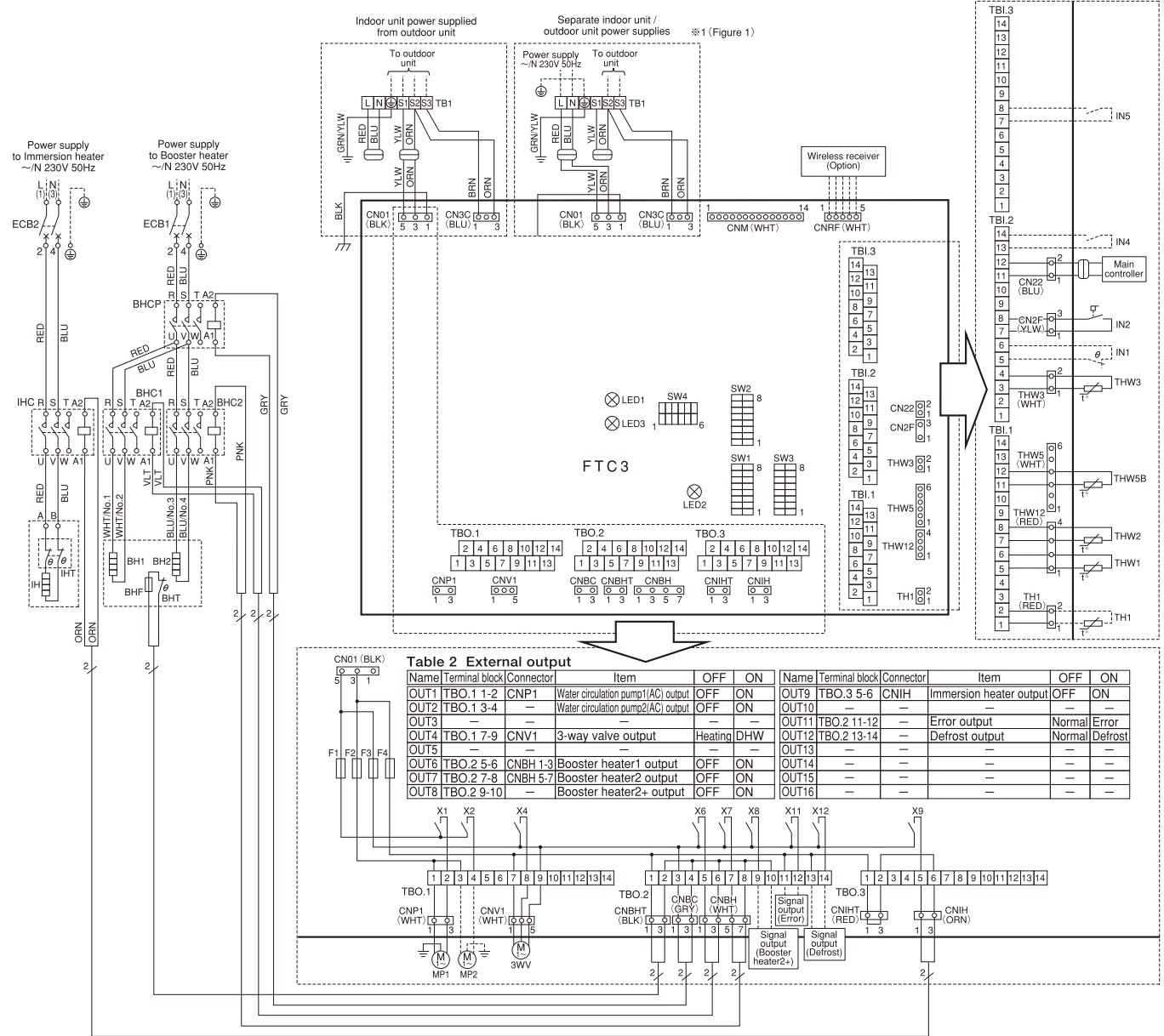

**Table 2 External output**

Name	Terminal block	Connector	Item	OFF	ON	Name	Terminal block	Connector	Item	OFF	ON
OUT1	TBO.1 1-2	CNP1	Water circulation pump1(AC) output	OFF	ON	OUT9	TBO.3 5-6	CNIH	Immersion heater output	OFF	ON
OUT2	TBO.1 3-4	—	Water circulation pump2(AC) output	OFF	ON	OUT10	—	—	—	—	—
OUT3	—	—	—	—	—	OUT11	TBO.2 11-12	—	Error output	Normal	Error
OUT4	TBO.1 7-9	CNV1	3-way valve output	Heating	DHW	OUT12	TBO.2 13-14	—	Defrost output	Normal	Defrost
OUT5	—	—	—	—	—	OUT13	—	—	—	—	—
OUT6	TBO.2 5-6	CNBH 1-3	Booster heater1 output	OFF	ON	OUT14	—	—	—	—	—
OUT7	TBO.2 7-8	CNBH 5-7	Booster heater2 output	OFF	ON	OUT15	—	—	—	—	—
OUT8	TBO.2 9-10	—	Booster heater2+ output	OFF	ON	OUT16	—	—	—	—	—

Symbol	Name	Remark
TB1	Terminal block (Power supply, Outdoor unit)	
ECB1	Earth leakage circuit breaker for booster heater	
ECB2	Earth leakage circuit breaker for immersion heater	
MP1	Water circulation pump1(AC)	OUT1(CNP1)
MP2	Water circulation pump2(AC)(Locally supplied)	OUT2
3WV	3-way valve	OUT4(CNV1)
BHT	Thermostat for booster heater	
BHF	Thermal fuse for booster heater	
BH1	Booster heater1	
BH2	Booster heater2	
BHC1	Contactor for booster heater1	
BHC2	Contactor for booster heater2	
BHCP	Contactor for booster heater protection	
IHT	Thermostat (Fixed temperature) for immersion heater	
IH	Immersion heater	
IHC	Contactor for immersion heater	

Symbol	Name
TH1	Thermistor(Room temp)(Option)
THW1	Thermistor(Flow water temp)
THW2	Thermistor(Return water temp)
THW5B	Thermistor(Tank water temp B)
THW3	Thermistor(Booster heater temp)
IN1	Room thermostat(Locally supplied)
IN2	Flow switch
IN4	Heat source OFF signal(Locally supplied)
IN5	Outdoor thermostat(Locally supplied)
FLOW TEMP. CONTROLLER(FTC3)	
TBO.1~3	Terminal block(External output)
TBI.1~3	Terminal block(External input contact signal, Thermistor)
F1~4	Fuse(T6.3A1250V)
SW1~4	Switch * See Chapter 6-10.
CNM	Connector(A-Control service tool)
X1,2,4~13	Relay
LED1	Power supply(FTC3)
LED2	Power supply(Main controller)
LED3	Communication(FTC3-Outdoor unit)

- Symbols used in wiring diagram are, [ ] : connector, [ ] : terminal block.
- Indoor unit and outdoor unit connecting wires have polarities, make sure to match terminal numbers (S1, S2, S3) for correct wirings.
- Since the outdoor unit side electric wiring may change, be sure to check the outdoor unit electric wiring diagram for servicing.
- This diagram shows the wiring of indoor unit and outdoor unit connecting wires (specification of 230V), adopting superimposed system of power and signal.  
※ 1: When work to supply power separately to indoor unit and outdoor unit was applied, refer to Figure 1.
- Do not connect to the terminals that are indicated as "-" in the "Terminal block" field of Table 2.
- Do not fit booster heater 2+ (locally supplied) without thermal cutout.

# 6-7. EHPT20X-YM9HA

**Table 1 External input**

Name	Terminal block	Connector	Item	OFF (Open)	ON (Short)
IN1	TBI.2 5-6	—	Room thermostat input	Refer to SW2-1	—
IN2	TBI.2 7-8	CN2F	Flow switch input	Refer to SW2-2	—
IN3	—	—	—	—	—
IN4	TBI.2 13-14	—	Heat source OFF input	Normal	Heat source OFF
IN5	TBI.3 7-8	—	Outdoor thermostat input	Standard operation	Heater operation
IN6	—	—	—	—	—
IN7	—	—	—	—	—
IN8	—	—	—	—	—

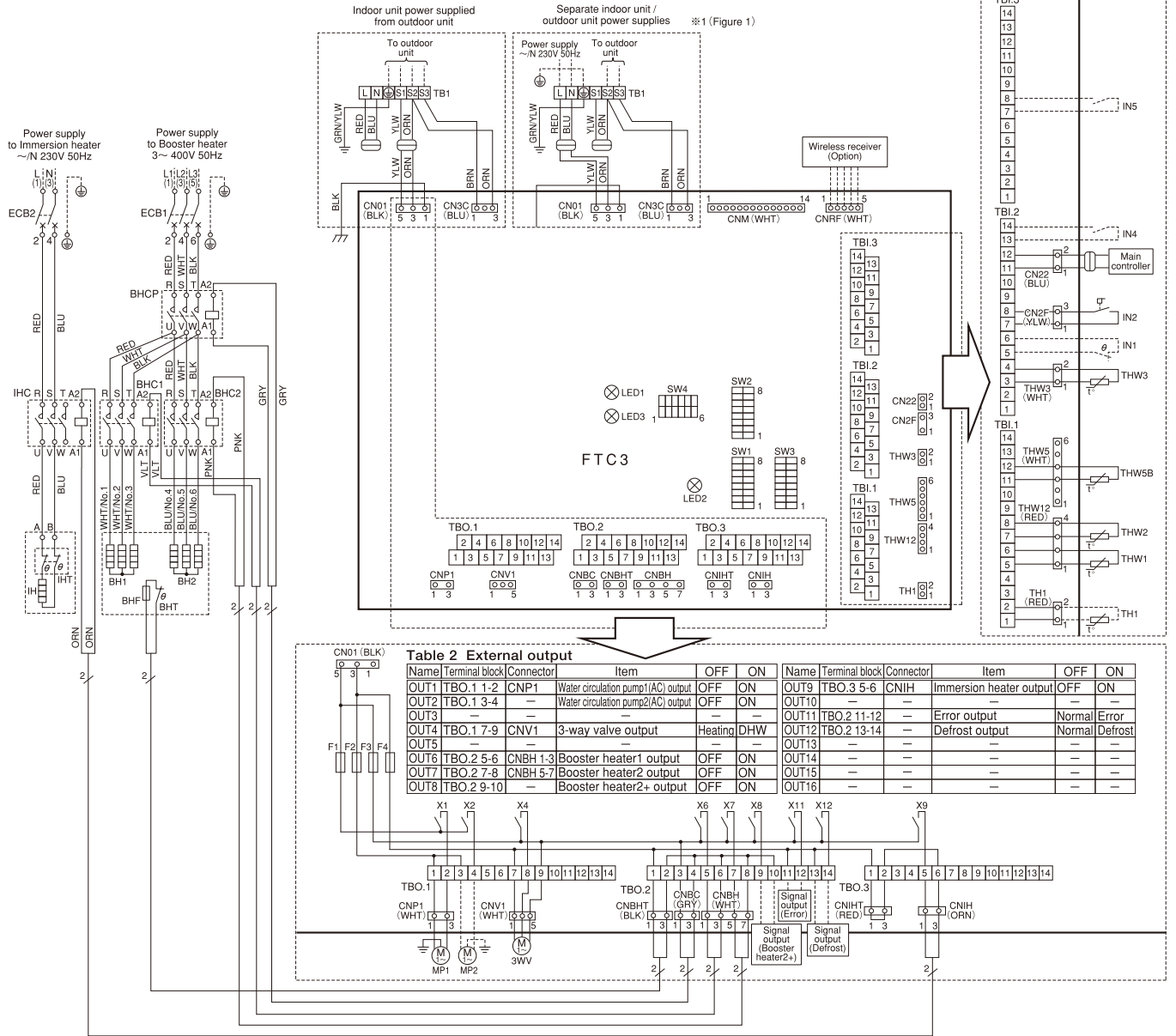

**Table 2 External output**

Name	Terminal block	Connector	Item	OFF	ON	Name	Terminal block	Connector	Item	OFF	ON
OUT1	TBO.1 1-2	CNP1	Water circulation pump1(AC) output	OFF	ON	OUT9	TBO.3 5-6	CNIH	Immersion heater output	OFF	ON
OUT2	TBO.1 3-4	—	Water circulation pump2(AC) output	OFF	ON	OUT10	—	—	—	—	—
OUT3	—	—	—	—	—	OUT11	TBO.2 11-12	—	Error output	Normal	Error
OUT4	TBO.1 7-9	CNV1	3-way valve output	Heating	DHW	OUT12	TBO.2 13-14	—	Defrost output	Normal	Defrost
OUT5	—	—	—	—	—	OUT13	—	—	—	—	—
OUT6	TBO.2 5-6	CNBH 1-3	Booster heater1 output	OFF	ON	OUT14	—	—	—	—	—
OUT7	TBO.2 7-8	CNBH 5-7	Booster heater2 output	OFF	ON	OUT15	—	—	—	—	—
OUT8	TBO.2 9-10	—	Booster heater2+ output	OFF	ON	OUT16	—	—	—	—	—

Symbol	Name	Remark
TB1	Terminal block (Power supply, Outdoor unit)	
ECB1	Earth leakage circuit breaker for booster heater	
ECB2	Earth leakage circuit breaker for immersion heater	
MP1	Water circulation pump1(AC)	OUT1(CNP1)
MP2	Water circulation pump2(AC)(Locally supplied)	OUT2
3WV	3-way valve	OUT4(CNV1)
BHT	Thermostat for booster heater	
BHF	Thermal fuse for booster heater	
BH1	Booster heater1	
BH2	Booster heater2	
BHC1	Contactor for booster heater1	
BHC2	Contactor for booster heater2	
BHCP	Contactor for booster heater protection	
IHT	Thermostat (Fixed temperature) for immersion heater	
IH	Immersion heater	
IHC	Contactor for immersion heater	

Symbol	Name
TH1	Thermistor(Room temp)(Option)
THW1	Thermistor(Flow water temp)
THW2	Thermistor(Return water temp)
THW5B	Thermistor(Tank water temp B)
THW3	Thermistor(Booster heater temp)
IN1	Room thermostat(Locally supplied)
IN2	Flow switch
IN4	Heat source OFF signal(Locally supplied)
IN5	Outdoor thermostat(Locally supplied)
FLOW TEMP. CONTROLLER(FTC3)	
TBO.1~3	Terminal block(External output)
TBI.1~3	Terminal block(External input contact signal, Thermistor)
F1~4	Fuse(T6, 3A/250V)
SW1~4	Switch * See Chapter 6-10.
CNM	Connector(A-Control service tool)
X1.2.4~13	Relay
LED1	Power supply(FTC3)
LED2	Power supply(Main controller)
LED3	Communication(FTC3-Outdoor unit)

- Symbols used in wiring diagram are, : connector, : terminal block.
- Indoor unit and outdoor unit connecting wires have polarities, make sure to match terminal numbers (S1, S2, S3) for correct wirings.
- Since the outdoor unit side electric wiring may change, be sure to check the outdoor unit electric wiring diagram for servicing.
- This diagram shows the wiring of indoor unit and outdoor unit connecting wires (specification of 230V), adopting superimposed system of power and signal.  
※1: When work to supply power separately to indoor unit and outdoor unit was applied, refer to Figure 1.
- Do not connect to the terminals that are indicated as "\*" in the "Terminal block" field of Table 2.
- Do not fit booster heater 2+ (locally supplied) without thermal cutout.



## 6-8. EHPT20X-VM6A

**Table 1 External input**

Name	Terminal block	Connector	Item	OFF (Open)	ON (Short)
IN1	TBI.2 5-6	—	Room thermostat input	Refer to SW2-1	—
IN2	TBI.2 7-8	CN2F	Flow switch input	Refer to SW2-2	—
IN3	—	—	—	—	—
IN4	TBI.2 13-14	—	Heat source OFF input	Normal	Heat source OFF
IN5	TBI.3 7-8	—	Outdoor thermostat input	Standard operation	Heater operation
IN6	—	—	—	—	—
IN7	—	—	—	—	—
IN8	—	—	—	— </tr	

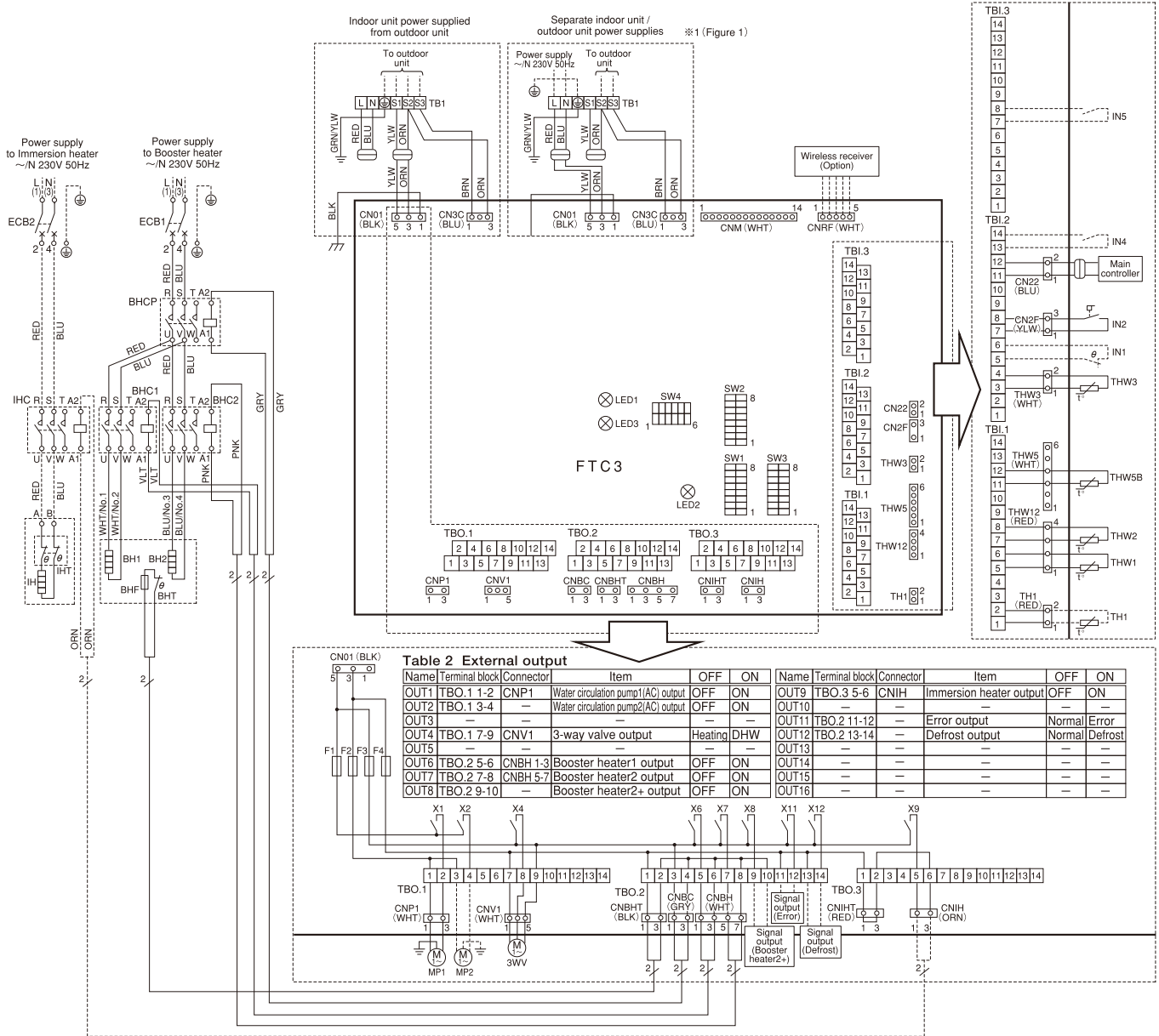

**Table 2 External output**

Name	Terminal block	Connector	Item	OFF	ON	Name	Terminal block	Connector	Item	OFF	ON
OUT1	TBO.1 1-2	CNP1	Water circulation pump1(AC) output	OFF	ON	OUT9	TBO.3 5-6	CNIH	Immersion heater output	OFF	ON
OUT2	TBO.1 3-4	—	Water circulation pump2(AC) output	OFF	ON	OUT10	—	—	—	—	—
OUT3	—	—	—	—	—	OUT11	TBO.2 11-12	—	Error output	Normal	Error
OUT4	TBO.1 7-9	CNV1	3-way valve output	Heating	DHW	OUT12	TBO.2 13-14	—	Defrost output	Normal	Defrost
OUT5	—	—	—	—	—	OUT13	—	—	—	—	—
OUT6	TBO.2 5-6	CNBH 1-3	Booster heater1 output	OFF	ON	OUT14	—	—	—	—	—
OUT7	TBO.2 7-8	CNBH 5-7	Booster heater2 output	OFF	ON	OUT15	—	—	—	—	—
OUT8	TBO.2 9-10	—	Booster heater2+ output	OFF	ON	OUT16	—	—	—	—	—

Symbol	Name	Remark
TB1	Terminal block (Power supply, Outdoor unit)	
ECB1	Earth leakage circuit breaker for booster heater	
ECB2	Earth leakage circuit breaker for immersion heater (Option)	
MP1	Water circulation pump1(AC)	OUT1(CNP1)
MP2	Water circulation pump2(AC)(Locally supplied)	OUT2
3WV	3-way valve	OUT4(CNV1)
BHT	Thermostat for booster heater	
BHF	Thermal fuse for booster heater	
BH1	Booster heater1	
BH2	Booster heater2	
BHC1	Contactor for booster heater1	
BHC2	Contactor for booster heater2	
BHCP	Contactor for booster heater protection	
IHT	Thermostat (Fixed temperature) for immersion heater (Option)	
IH	Immersion heater(Option)	
IHC	Contactor for immersion heater(Option)	

Symbol	Name
TH1	Thermistor(Room temp)(Option)
THW1	Thermistor(Flow water temp)
THW2	Thermistor(Return water temp)
THW5B	Thermistor(Tank water temp B)
THW3	Thermistor(Booster heater temp)
IN1	Room thermostat(Locally supplied)
IN2	Flow switch
IN4	Heat source OFF signal(Locally supplied)
IN5	Outdoor thermostat(Locally supplied)
FLOW TEMP. CONTROLLER(FTC3)	
TBO.1~3	Terminal block(External output)
TBI.1~3	Terminal block(External input contact signal, Thermistor)
F1~4	Fuse(T6,3AL250V)
SW1~4	Switch * See Chapter 6-10.
CNM	Connector(A-Control service tool)
X1.2.4~13	Relay
LED1	Power supply(FTC3)
LED2	Power supply(Main controller)
LED3	Communication(FTC3-Outdoor unit)

- Symbols used in wiring diagram are,  $\square$ : connector,  $\square$ : terminal block.
- Indoor unit and outdoor unit connecting wires have polarities, make sure to match terminal numbers (S1, S2, S3) for correct wirings.
- Since the outdoor unit side electric wiring may change, be sure to check the outdoor unit electric wiring diagram for servicing.
- This diagram shows the wiring of indoor unit and outdoor unit connecting wires (specification of 230V), adopting superimposed system of power and signal.  
※1: When work to supply power separately to indoor unit and outdoor unit was applied, refer to Figure 1.
- Do not connect to the terminals that are indicated as "-" in the "Terminal block" field of Table 2.
- Do not fit booster heater 2+ (locally supplied) without thermal cutout.

## 6-9. EHPT20X-YM9A

**Table 1 External input**

Name	Terminal block	Connector	Item	OFF (Open)	ON (Short)
IN1	TBI.2 5-6	—	Room thermostat input	Refer to SW2-1	—
IN2	TBI.2 7-8	CN2F	Flow switch input	Refer to SW2-2	—
IN3	—	—	—	—	—
IN4	TBI.2 13-14	—	Heat source OFF input	Normal	Heat source OFF
IN5	TBI.3 7-8	—	Outdoor thermostat input	Standard operation	Heater operation
IN6	—	—	—	—	—
IN7	—	—	—	—	—
IN8	—	—	—	—	—

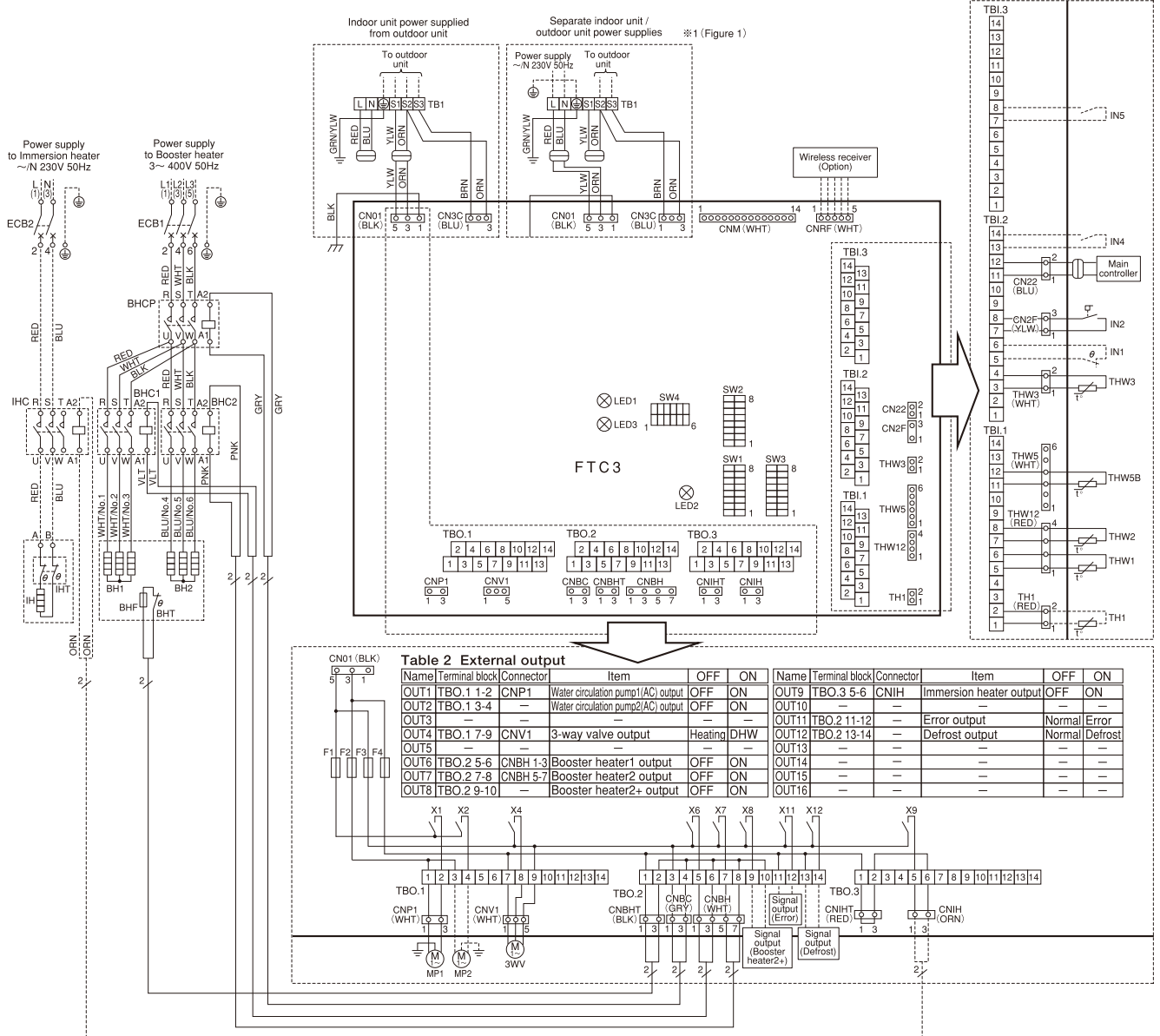

Symbol	Name	Remark
TB1	Terminal block (Power supply, Outdoor unit)	
ECB1	Earth leakage circuit breaker for booster heater	
ECB2	Earth leakage circuit breaker for immersion heater (Option)	
MP1	Water circulation pump1(AC)	OUT1(CNP1)
MP2	Water circulation pump2(AC)(Locally supplied)	OUT2
3WV	3-way valve	OUT4(CNV1)
BHT	Thermostat for booster heater	
BHF	Thermal fuse for booster heater	
BH1	Booster heater1	
BH2	Booster heater2	
BHC1	Contactor for booster heater1	
BHC2	Contactor for booster heater2	
BHCP	Contactor for booster heater protection	
IHT	Thermostat (Fixed temperature) for immersion heater (Option)	
IH	Immersion heater(Option)	
IHC	Contactor for immersion heater(Option)	

Symbol	Name
TH1	Thermistor(Room temp)(Option)
THW1	Thermistor(Flow water temp)
THW2	Thermistor(Return water temp)
THW5B	Thermistor(Tank water temp B)
THW3	Thermistor(Booster heater temp)
IN1	Room thermostat(Locally supplied)
IN2	Flow switch
IN4	Heat source OFF signal(Locally supplied)
IN5	Outdoor thermostat(Locally supplied)
<b>FLOW TEMP. CONTROLLER(FTC3)</b>	
TBO.1~3	Terminal block(External output)
TBI.1~3	Terminal block(External input contact signal, Thermistor)
F1~4	Fuse(T6.3A1250V)
SW1~4	Switch * See Chapter 6-10.
CNM	Connector(A-Control service tool)
X1.2.4~13	Relay
LED1	Power supply(FTC3)
LED2	Power supply(Main controller)
LED3	Communication(FTC3-Outdoor unit)

- Symbols used in wiring diagram are, : connector, : terminal block.
- Indoor unit and outdoor unit connecting wires have polarities, make sure to match terminal numbers (S1, S2, S3) for correct wirings.
- Since the outdoor unit side electric wiring may change, be sure to check the outdoor unit electric wiring diagram for servicing.
- This diagram shows the wiring of indoor unit and outdoor unit connecting wires (specification of 230V), adopting superimposed system of power and signal.  
※1: When work to supply power separately to indoor unit and outdoor unit was applied, refer to Figure 1.
- Do not connect to the terminals that are indicated as "-" in the "Terminal block" field of Table 2.
- Do not fit booster heater 2+ (locally supplied) without thermal cutout.

## 6-10. Dip switch setting

### <Dip Switch Functions>

Located on the FTC3 printed circuit board are 4 sets of small white switches known as Dip switches. The Dip switch number is printed on the circuit board next to the relevant switches. The word ON is printed on the circuit board and on the Dip switch block itself. To move the switch you will need to use a pin or the corner of a thin metal ruler or similar.

Dip switch settings are listed below in the table below.

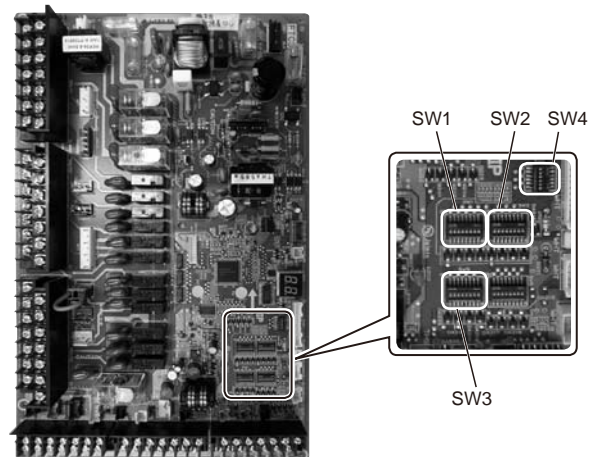

Dip switch		Function	OFF	ON	Default (Indoor unit Ref.)
SW1	SW1-1	—	—	—	OFF
	SW1-2	Heat pump maximum outlet water temperature	55 °C	60 °C	OFF:EHS****-M** (*1) ON :EHP****-M**
	SW1-3	DHW tank	WITHOUT DHW tank	WITH DHW tank	ON
	SW1-4	Immersion heater	WITHOUT immersion heater	WITH immersion heater	OFF:EH*****M** ON :EH*****M**H*
	SW1-5	Booster heater	WITHOUT booster heater	WITH booster heater	ON
	SW1-6	Booster heater function	For heating only	For heating and DHW	ON
	SW1-7	Outdoor unit type	Split type	Packaged type	OFF:EHS****-M** ON :EHP****-M**
	SW1-8	Wireless remote controller	WITHOUT wireless remote controller	WITH wireless remote controller	OFF
SW2	SW2-1	Room thermostat input (IN1) logic change	Operation stop at thermostat short	Operation stop at thermostat open	OFF
	SW2-2	Flow switch input (IN2) logic change	Failure detection at short	Failure detection at open	ON
	SW2-3	Booster heater capacity restriction	Inactive	Active	OFF ON: EHPT20X-VM2HA
	SW2-4	—	—	—	OFF
	SW2-5	Automatic switch to backup heater only operation (When outdoor unit stops by error)	Inactive	Active (*3)	OFF
	SW2-6	—	—	—	OFF
	SW2-7	—	—	—	OFF
	SW2-8	—	—	—	OFF
SW3	SW3-1	—	—	—	OFF
	SW3-2	—	—	—	OFF
	SW3-3	—	—	—	OFF
	SW3-4-8	—	—	—	OFF
SW4	SW4-1-4	—	—	—	OFF
	SW4-5	Emergency mode (Heater only operation)	Normal	Emergency mode (Heater only operation) (To be activated only when powered ON)	OFF (*2)
	SW4-6	—	—	—	OFF

- Notes:
- \*1. For packaged model system, the max outlet water temperature is always 60°C so default Dip switch SW1-2 is ON.  
For split model system, the max outlet water temperature is usually 55°C except in the case of PUHZ-HRP outdoor model where the max outlet water temperature is 60°C and DIP switch SW1-2 should be changed to ON.
  - \*2. If emergency mode is no longer required, please turn off both outdoor and indoor unit power supply before returning SW4-5 to OFF position.
  - \*3. For safety reasons, this function is not available for certain errors. (System operation must be stopped and only pump keeps running.)  
External output (OUT11) will be available.

### ■ Automatic switch to backup heater only operation

Back-up heater operation (\*1) will automatically run when the indoor unit stops abnormally.  
To enable the function, switch Dip SW 2-5 to ON.  
During the back-up operation, an error code(s) and the contact number will be displayed alternately.  
External output (OUT11) will be available.  
To clear the fault(s), reset the power breakers on the indoor and outdoor units.

<Applicable error codes (\*2)>  
E6 to E9, Ed, P8, U1 to U8, Ud, UE, UF, UL, UP

- (\*1) Prolonged running of the back-up operation may affect the life of the heater.
- (\*2) For safety reasons, this function is not available for certain faults. (System operation must be stopped and only pump keeps running.)



# 7

# FIELD WIRING

Option 1: Cylinder unit powered via outdoor unit  
**<1 phase>**

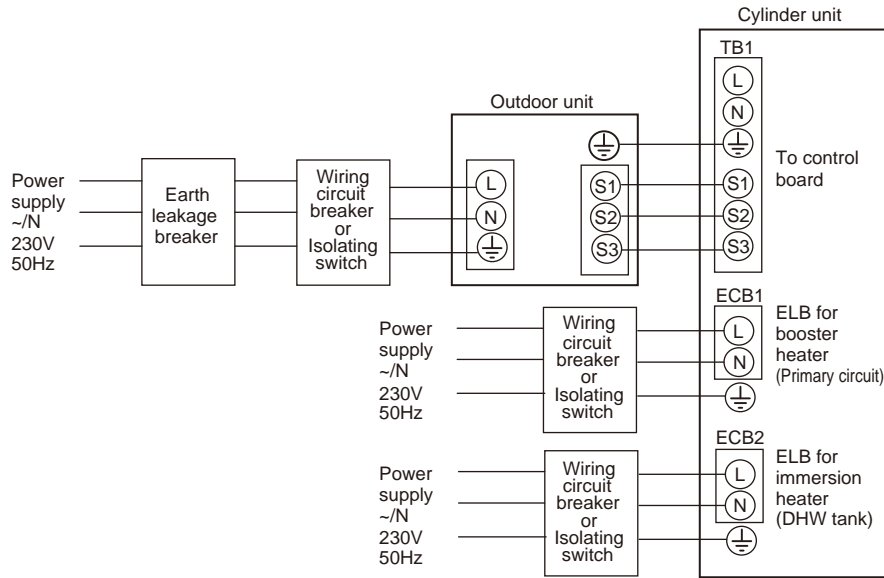

\* Installer MUST affix label A that is included with the manuals near each wiring diagram for cylinder and outdoor units.

<Figure 7-1>  
 Electrical connections 1 phase

Description	Power supply	Capacity (Indoor unit Ref.)	Breaker	Wiring
Booster heater (Primary circuit)	~N 230 V 50 Hz	2 kW (E*****-VM2**)	16 A *1	2.5 mm <sup>2</sup>
		6 kW (E*****-VM6**)	32 A *1	6.0 mm <sup>2</sup>
Immersion heater (DHW tank)	~N 230 V 50 Hz	3 kW (E*****-VM*H*)	16 A *1	2.5 mm <sup>2</sup>

Wiring Wiring No. x size (mm <sup>2</sup> )	Cylinder unit - Outdoor unit	*2	3 x 1.5 (polar)
	Cylinder unit - Outdoor unit earth	*2	1 x Min. 1.5
Circuit rating	Cylinder unit - Outdoor unit S1 - S2	*3	AC230V
	Cylinder unit - Outdoor unit S2 - S3	*3	DC24V

\*1. A breaker with at least 3.0 mm contact separation in each pole shall be provided. Use earth leakage breaker (NV). The breaker shall be provided to ensure disconnection of all active phase conductors of the supply.

\*2. Max. 45 m  
 If 2.5 mm<sup>2</sup> used, Max. 50 m  
 If 2.5 mm<sup>2</sup> used and S3 separated, Max. 80 m

\*3. The values given in the table above are not always measured against the ground value.

- Notes:**
1. Wiring size must comply with the applicable local and national codes.
  2. Indoor unit/outdoor unit connecting cords shall not be lighter than polychloroprene sheathed flexible cord. (Design 60245 IEC 57)  
 Indoor unit power supply cords shall not be lighter than polychloroprene sheathed flexible cord. (Design 60227 IEC 53)
  3. Install an earth longer than other cables.
  4. The power supply MUST have sufficient capacity for each heater and ALL electrical loads. Insufficient power supply may result in chattering of load contactor(s).

<3 phase>

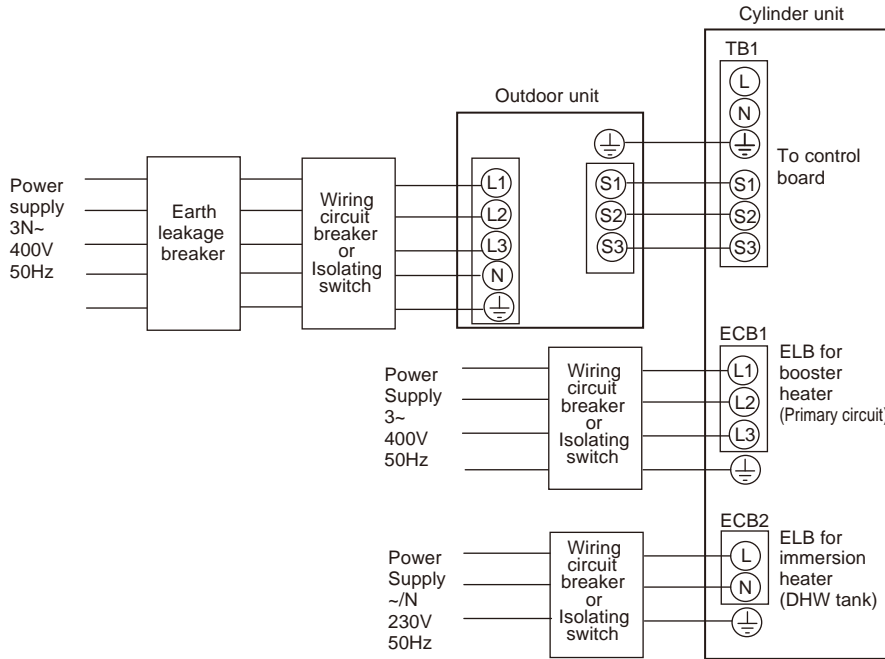

\* Installer MUST affix label A that is included with the manuals near each wiring diagram for cylinder and outdoor units.

<Figure 7-2>  
Electrical connections 3 phase

Description	Power supply	Capacity (Indoor unit Ref.)	Breaker	Wiring
Booster heater (Primary circuit)	3~ 400V 50Hz	9 kW	16 A *1	2.5 mm <sup>2</sup>
Immersion heater (DHW tank)	~N 230 V 50 Hz	3kW (E*****-VM*H*)	16 A *1	2.5 mm <sup>2</sup>

Wiring No. x size (mm <sup>2</sup> )	Cylinder unit - Outdoor unit	*2	3 x 1.5 (polar)
	Cylinder unit - Outdoor unit earth	*2	1 x Min. 1.5
Circuit rating	Cylinder unit - Outdoor unit S1 - S2	*3	AC230V
	Cylinder unit - Outdoor unit S2 - S3	*3	DC24V

- \*1. A breaker with at least 3.0 mm contact separation in each pole shall be provided. Use earth leakage breaker (NV). The breaker shall be provided to ensure disconnection of all active phase conductors of the supply.
- \*2. Max. 45 m  
If 2.5 mm<sup>2</sup> used, Max. 50 m  
If 2.5 mm<sup>2</sup> used and S3 separated, Max. 80 m
- \*3. The values given in the table above are not always measured against the ground value.

- Notes:**
1. Wiring size must comply with the applicable local and national codes.
  2. Indoor unit/outdoor unit connecting cords shall not be lighter than polychloroprene sheathed flexible cord. (Design 60245 IEC 57)  
Indoor unit power supply cords shall not be lighter than polychloroprene sheathed flexible cord. (Design 60227 IEC 53)
  3. Install an earth longer than other cables.
  4. The power supply MUST have sufficient capacity for each heater and ALL electrical loads. Insufficient power supply may result in chattering of load contactor(s).

Option2: Cylinder unit powered by independent source.

If the cylinder and outdoor units have separate power supplies, the following requirements MUST be carried out:

- Cylinder unit electrical box connector connections changed (see Figure 7-3)
- Outdoor unit DIP switch settings changed to SW8-3 ON
- Turn on the outdoor unit before the cylinder unit.

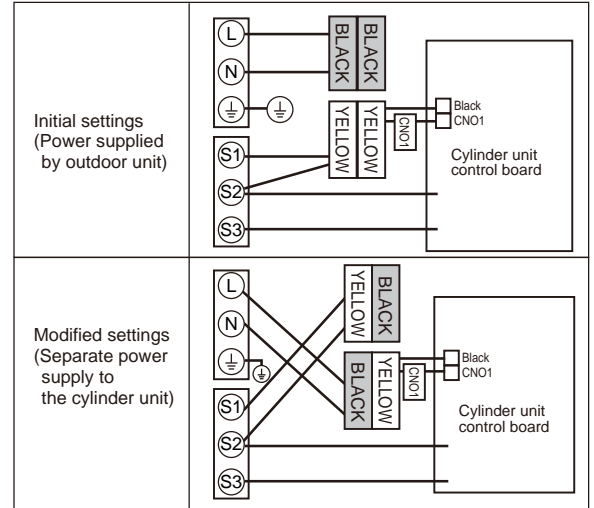

<Figure 7-3>

<1 phase>

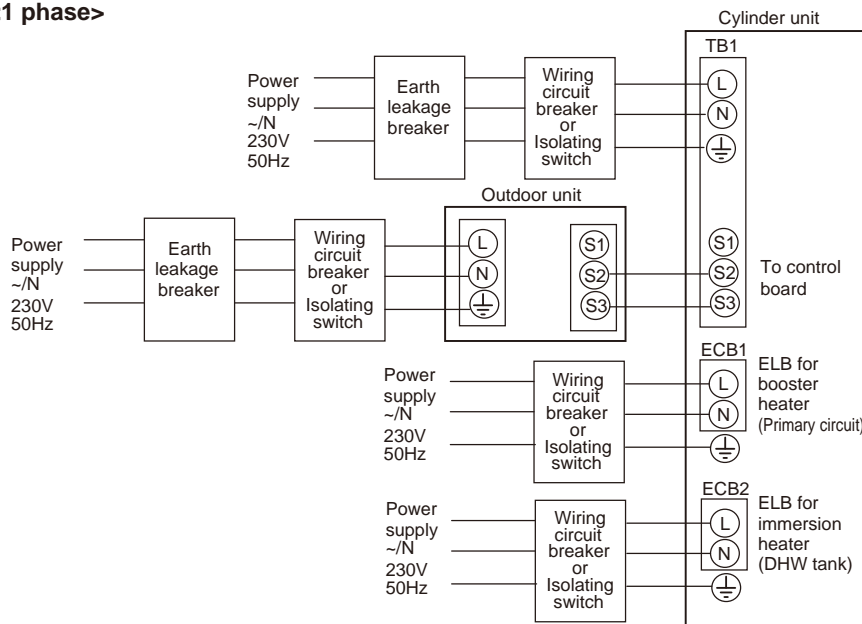

\* Installer MUST affix label A that is included with the manuals near each wiring diagram for cylinder and outdoor units.

<Figure 7-4>

Electrical connections 1 phase

Description	Power supply	Capacity (Indoor unit Ref.)	Breaker	Wiring
Booster heater (Primary circuit)	~N 230 V 50 Hz	2 kW (E*****-VM2**)	16 A *1	2.5 mm <sup>2</sup>
		6 kW (E*****-VM6**)	32 A *1	6.0 mm <sup>2</sup>
Immersion heater (DHW tank)	~N 230 V 50 Hz	3kW (E*****-VM*H*)	16 A *1	2.5 mm <sup>2</sup>

Cylinder unit power supply		~N 230 V 50 Hz
Cylinder unit input capacity		
Main switch (Breaker)		*1 16 A
Wiring No. x size (mm <sup>2</sup> )	Cylinder unit power supply	2 x Min. 1.5
	Cylinder unit power supply earth	1 x Min. 1.5
	Cylinder unit - Outdoor unit	*2 2 x Min. 0.3
	Cylinder unit - Outdoor unit earth	—
Circuit rating	Cylinder unit L - N	*3 AC230V
	Cylinder unit - Outdoor unit S1 - S2	*3 —
	Cylinder unit - Outdoor unit S2 - S3	*3 DC24V

\*1. A breaker with at least 3.0 mm contact separation in each pole shall be provided. Use earth leakage breaker (NV). The breaker shall be provided to ensure disconnection of all active phase conductors of the supply.

\*2. Max. 120 m

\*3. The values given in the table above are not always measured against the ground value.

- Notes:
1. Wiring size must comply with the applicable local and national codes.
  2. Indoor unit/outdoor unit connecting cords shall not be lighter than polychloroprene sheathed flexible cord. (Design 60245 IEC 57)  
Indoor unit power supply cords shall not be lighter than polychloroprene sheathed flexible cord. (Design 60227 IEC 53)
  3. Install an earth longer than other cables.
  4. The power supply MUST have sufficient capacity for each heater and ALL electrical loads. Insufficient power supply may result in chattering of load contactor(s).

<3 phase>

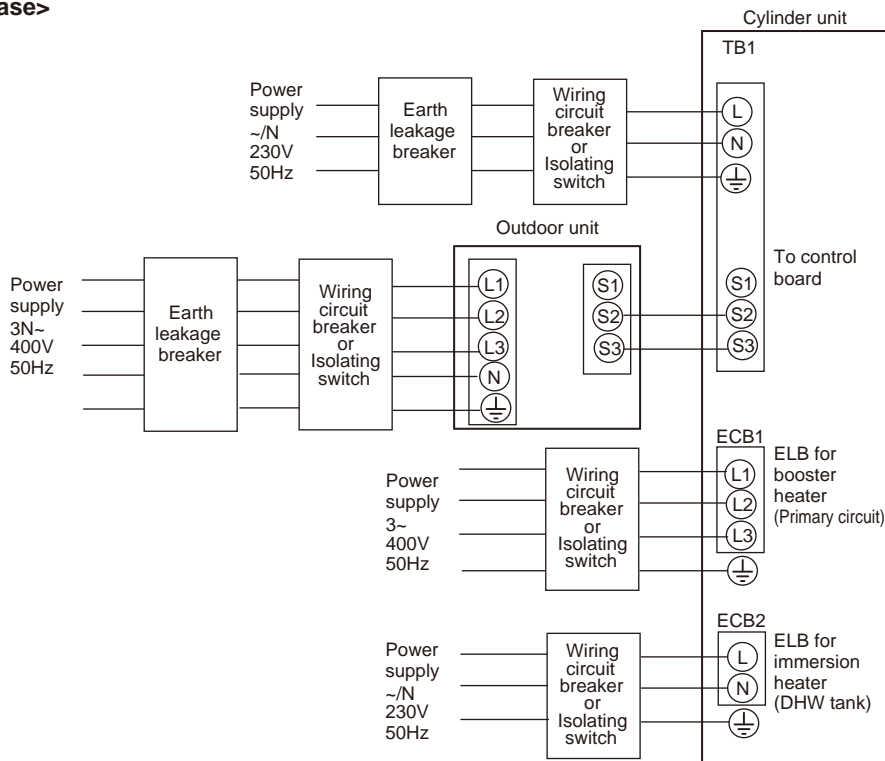

\* Installer MUST affix label A that is included with the manuals near each wiring diagram for cylinder and outdoor units.

<Figure 7-5>  
Electrical connections 3 phase

Description	Power supply	Capacity (Indoor unit Ref.)	Breaker	Wiring
Booster heater (Primary circuit)	3~ 400V 50Hz	9 kW	16 A *1	2.5 mm <sup>2</sup>
Immersion heater (DHW tank)	~N 230 V 50 Hz	3kW (E*****-VM*H*)	16 A *1	2.5 mm <sup>2</sup>

Cylinder unit power supply		~N 230 V 50 Hz
Cylinder unit input capacity Main switch (Breaker)		*1 16 A
Wiring No. x size (mm <sup>2</sup> )	Cylinder unit power supply	2 x Min. 1.5
	Cylinder unit power supply earth	1 x Min. 1.5
	Cylinder unit - Outdoor unit	*2 2 x Min. 0.3
	Cylinder unit - Outdoor unit earth	—
Circuit rating	Cylinder unit L - N	*3 AC230V
	Cylinder unit - Outdoor unit S1 - S2	*3 —
	Cylinder unit - Outdoor unit S2 - S3	*3 DC24V

\*1. A breaker with at least 3.0 mm contact separation in each pole shall be provided. Use earth leakage breaker (NV).  
The breaker shall be provided to ensure disconnection of all active phase conductors of the supply.

\*2. Max. 120 m

\*3. The values given in the table above are not always measured against the ground value.

- Notes:**
1. Wiring size must comply with the applicable local and national codes.
  2. Indoor unit/outdoor unit connecting cords shall not be lighter than polychloroprene sheathed flexible cord. (Design 60245 IEC 57)  
Indoor unit power supply cords shall not be lighter than polychloroprene sheathed flexible cord. (Design 60227 IEC 53)
  3. Install an earth longer than other cables.
  4. The power supply MUST have sufficient capacity for each heater and ALL electrical loads. Insufficient power supply may result in chattering of load contactor(s).

**EHST20C-\*M\*HA / \*M\*A**

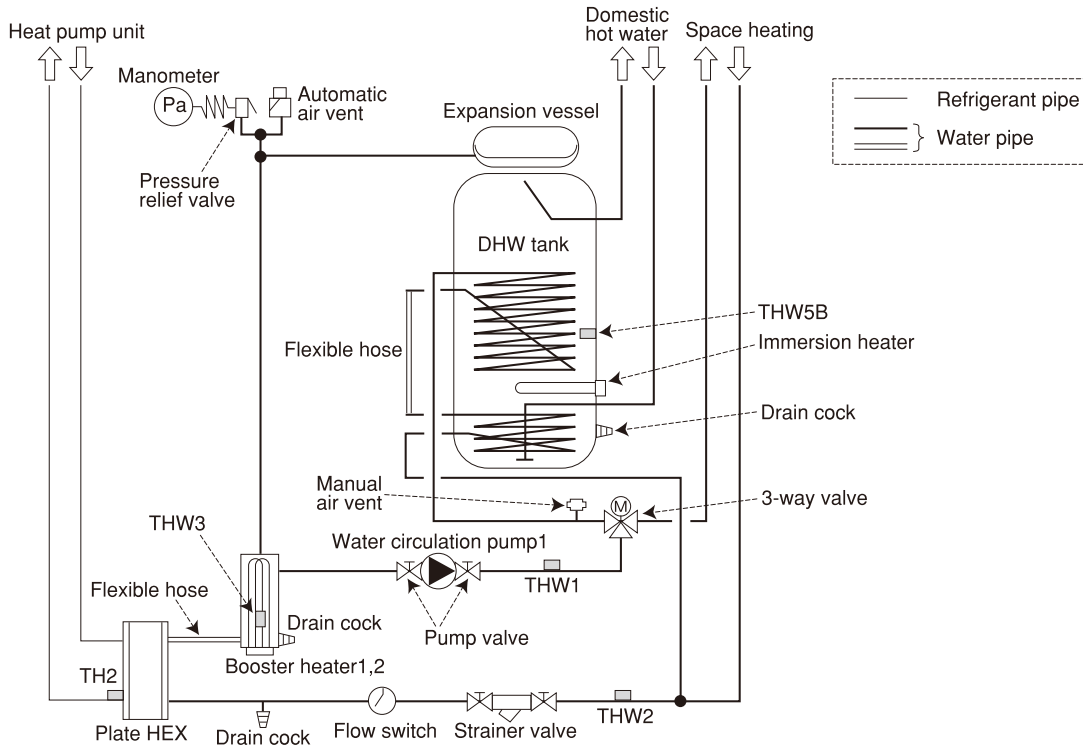

**EHST20C-VM6SA**

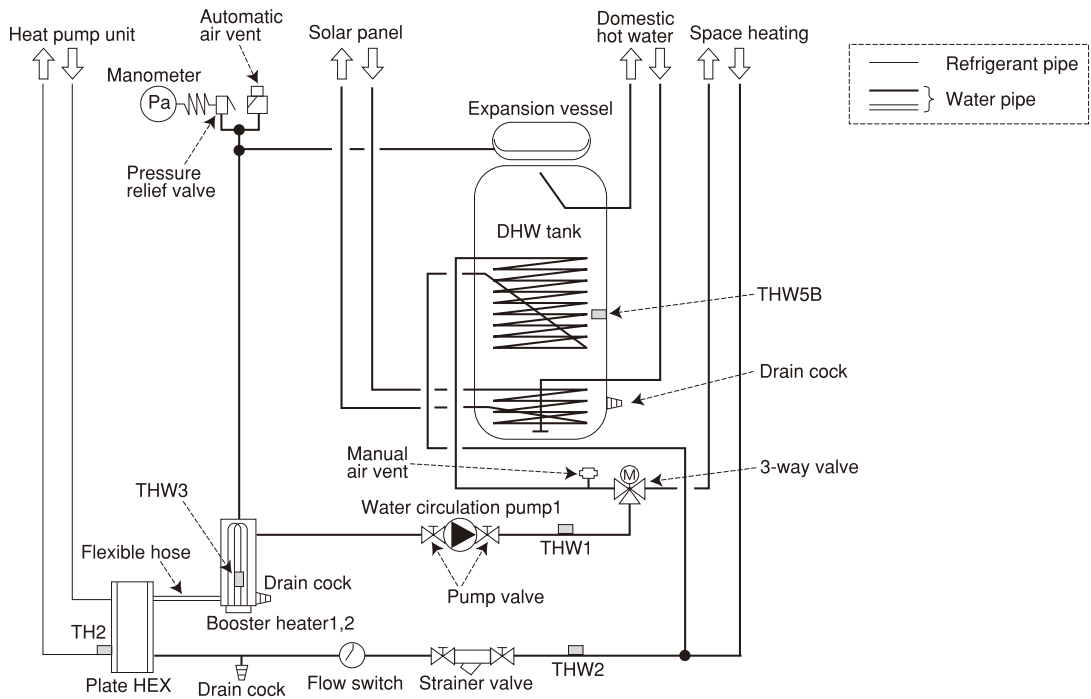

**EHPT20X-VM2HA**

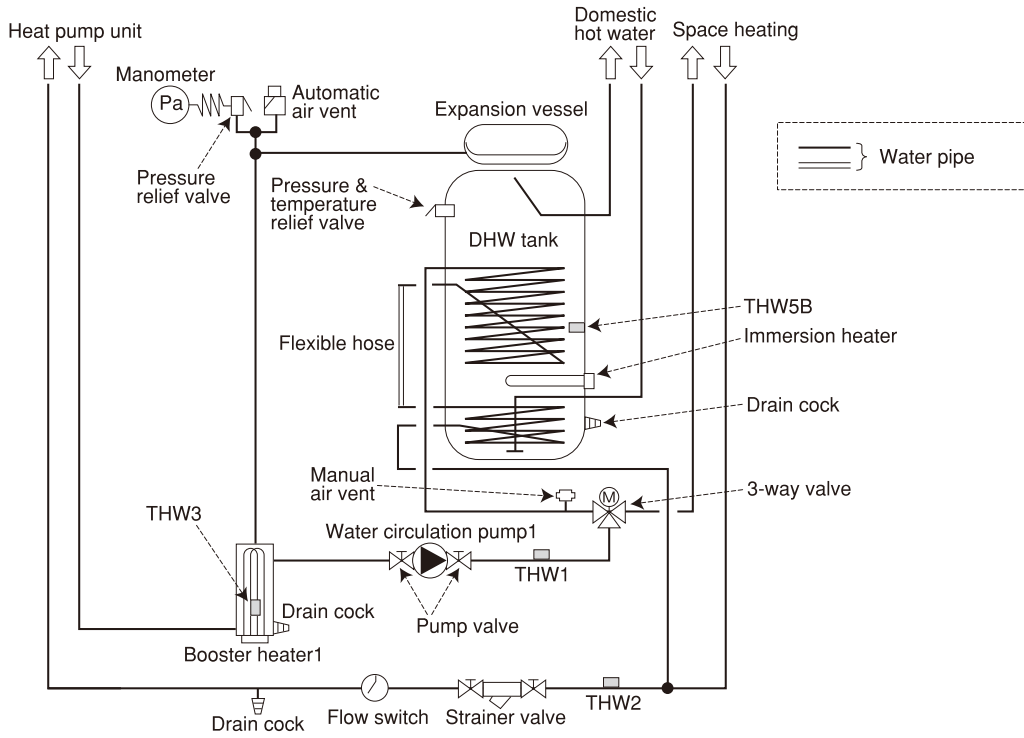

**EHPT20X-\*M\*HA / \*M\*A**

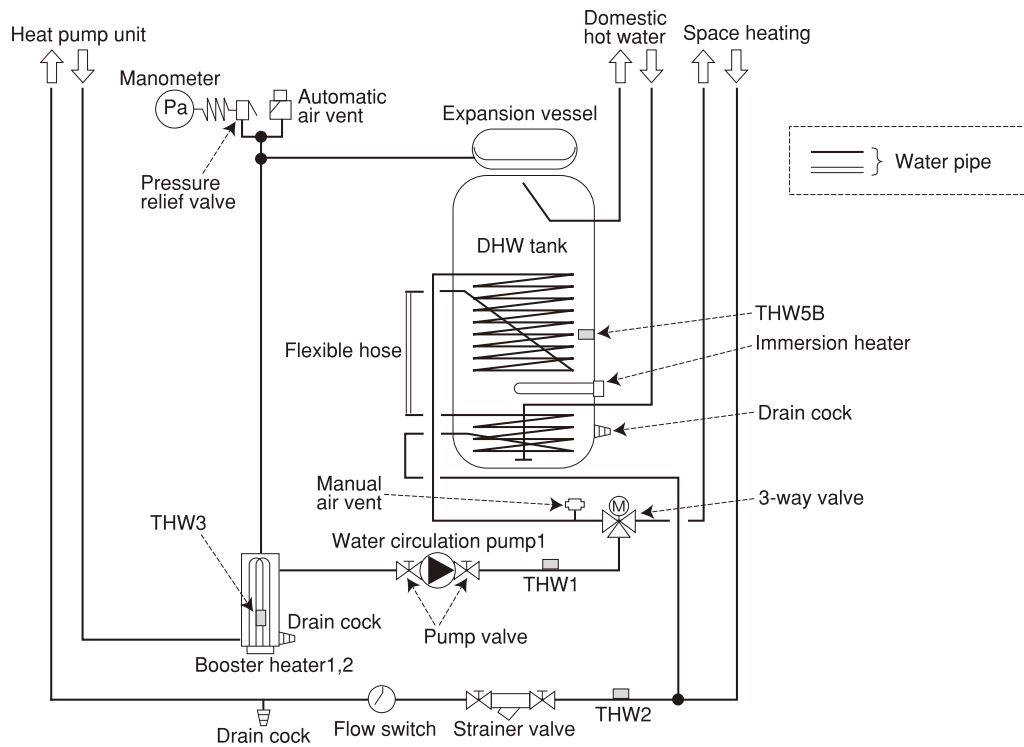

## Filling the cylinder unit

1. Check all connections including factory fitted ones are tight.
2. Insulate pipe work between cylinder and outdoor unit.
3. Thoroughly clean and flush, system of all debris. (see section 4.2 of Installation Manual for detailed instructions.)
4. Fill cylinder with potable water. Fill primary heating circuit with water and suitable anti-freeze and inhibitor as necessary. **Always use a filling loop with double check valve when filling the primary circuit to avoid back flow contamination of water supply.**

- Anti-freeze should always be used for package systems. It is the responsibility of the installer to decide if anti-freeze solution should be used in split systems depending on each site's conditions. Corrosion inhibitor should be used in both split and package systems.
- When connecting metal pipes of different materials insulate the joints to prevent a corrosive reaction taking place which will damage the pipework.

5. Check for leaks. If leaks are found, retighten the screws on the connections.
6. Pressurise system to 1 bar.
7. Release all trapped air using air vents during and following heating period.
8. Top up with water as necessary. (If pressure falls below 1 bar)

## Filling the cylinder unit (Potable/DHW circuit)

Initial fill procedure:

1. Ensure all pipe joints and fittings are tight and secure.
2. Open the most distant DHW tap/outlet.
3. Slowly/gradually open the mains water supply to begin filling unit and DHW pipework.
4. Allow most distant tap to run free and release/purge residual air from installation.
5. Close tap/outlet to retain fully charged system.

Initial flush procedure:

1. Energise system to heat-up cylinder contents to a temperature of approx. 30 – 40°C.
2. Flush/drain the water contents to remove any residue/impurities resulting from the installation works. Use the cylinder drain cock to safely discharge the warmed water to drain via a suitable hose.
3. On completion, close drain cock, re-fill system and resume system commissioning.

## Draining the cylinder unit

### **WARNING: DRAINED WATER MAY BE VERY HOT**

1. Before attempting to drain the cylinder isolate from the electrical supply to prevent the immersion and booster heaters burning out.
2. Isolate cold water feed to tank.
3. Attach a hose to the tank drain cock (No. 17 on Figure 4-1 to 4-4). The hose should be able to withstand heat as the emptied water could be very hot. The hose should drain to a place lower than the tank bottom to encourage siphoning.  
Open a hot water tap to start draining without a vacuum.
4. When the tank is drained close drain cock and hot tap.
5. Attach hose to booster heater drain cock and water circuit drain cock (No.13 and No. 16 on Figure 4-1 to 4-4). The hose should be able to withstand heat as the emptied water could be very hot. The hose should drain to a place lower than the booster heater drain cock to encourage siphoning. Open the pump valves and the strainer valves.
6. Water remains in the strainer still after the cylinder unit was drained.  
Drain the strainer by removing the strainer cover.

9-1. Main Controller

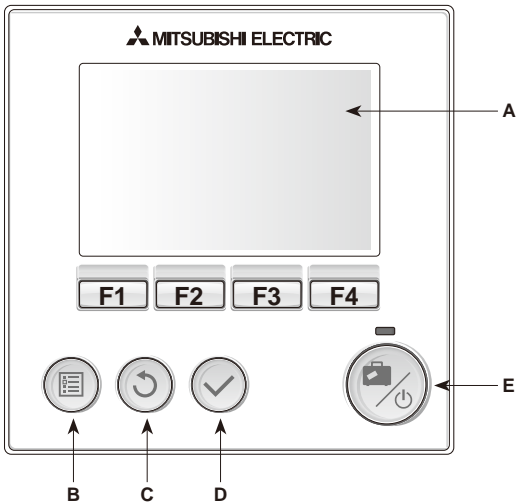

<Main controller parts>

Letter	Name	Function
A	Screen	Screen in which all information is displayed
B	Menu	Access to system settings for initial set up and modifications.
C	Back	Return to previous menu.
D	Confirm	Used to select or save. (Enter key)
E	Power/Holiday	If system is switched off pressing once will turn system on. Pressing again when system is switched on will enable Holiday Mode. Holding the button down for 3 secs will turn the system off. (*1)
F1-4	Function keys	Used to scroll through menu and adjust settings. Function is determined by the menu screen visible on screen A.

\*1

When the system is switched off or the power supply is disconnected, the cylinder protection functions (e.g. freeze stat. function) will NOT operate. Please beware that without these safety functions enabled the water circuit is exposed to risk and may, potentially, be damaged.

<Main screen icons>

	Icon	Description
1	Legionella prevention	When this icon is displayed 'Legionella prevention mode' is active.
2	Heat pump	When this icon is displayed the 'Heat pump' is in use.
3	Electric heater	When this icon is displayed the 'Electric heaters' are in use.
4	Target temperature	Target flow temperature
		Target room temperature
		Compensation curve
5	OPTION	Pressing the function button below this icon will display the quick view menu.
6	+	Increase desired temperature.
7	-	Decrease desired temperature.
8	Information	Pressing the function button below this icon displays the information screen.
9	Space heating mode	Heating mode
10	DHW mode	Normal or ECO mode
11	Holiday mode	When this icon is displayed 'Holiday mode' activated.
12	⌚	Timer
	⊘	Prohibited
	⏸	Stand-by
	⏹	Stop
	▶	Operating

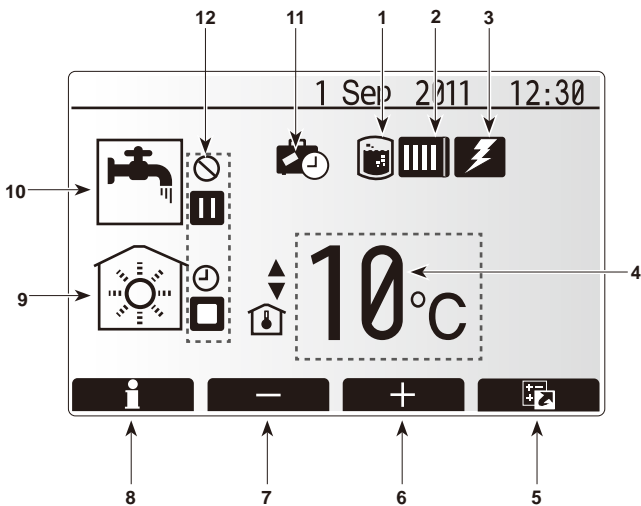



<Main Controller Menu Tree>

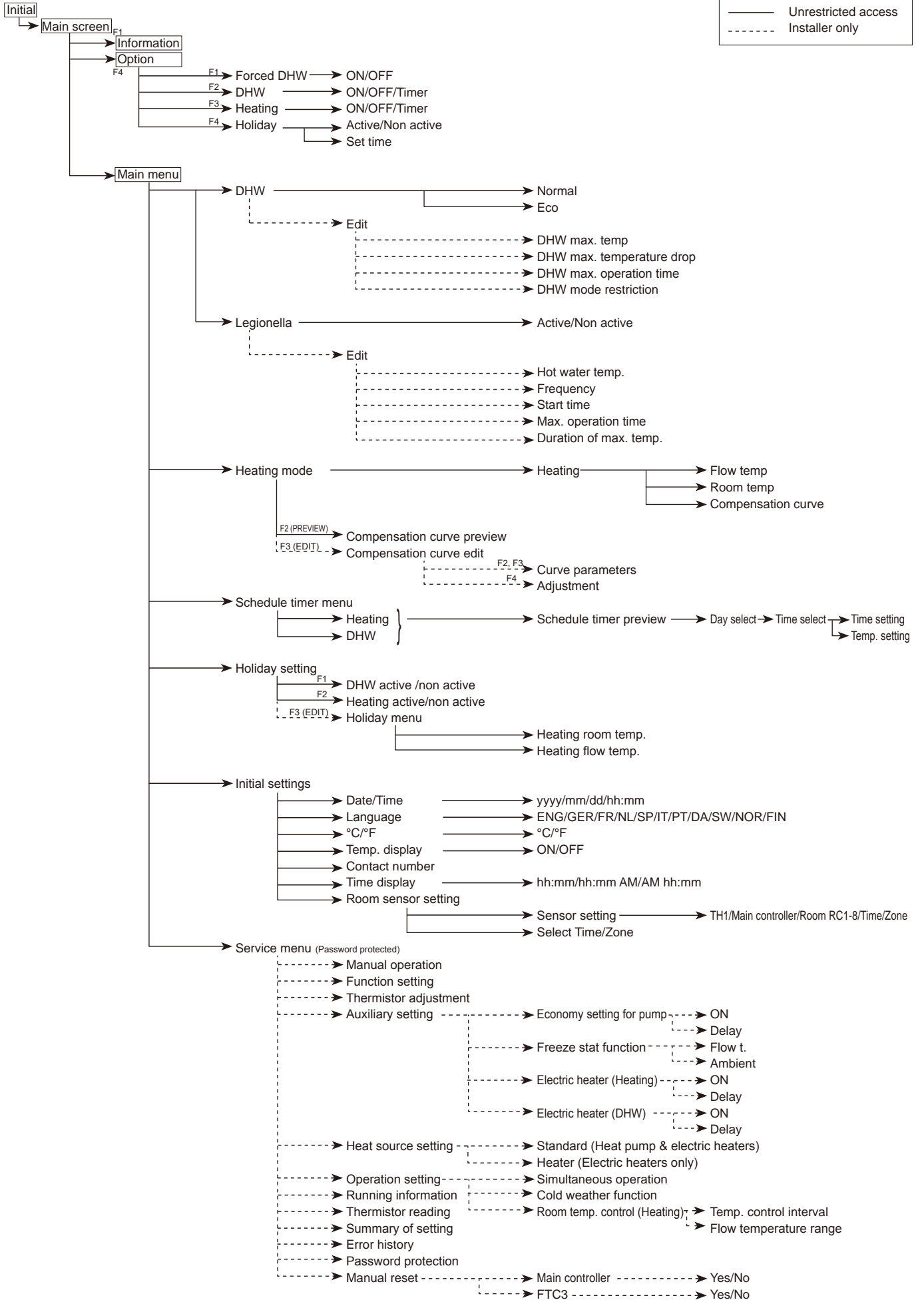

## 9-2. Service Menu

The service menu provides functions for use by installer or service engineer. It is NOT intended the home owner alters settings within this menu. It is for this reason password protection is required to prevent unauthorised access to the service settings.

1. From the main setting menu use F2 and F3 to highlight the service icon then press CONFIRM.
2. You will be prompted to enter a password. **THE FACTORY DEFAULT PASSWORD IS 0000.**
3. Press CONFIRM.  
(It takes approx. 30 secs to load the service menu.)

The service menu is navigated using the F1 and F2 buttons to scroll through the functions. The menu is split across two screens and is comprised of the following functions;

1. Manual operation
2. Function setting
3. Thermistor adjustment
4. Auxiliary setting
5. Heat source setting
6. Operation setting
7. Running information
8. Thermistor reading
9. Summary of setting
10. Error history
11. Password protection
12. Manual reset

In this Installation Manual instructions will be given only for the following functions;

1. Auxiliary setting
2. Manual operation
3. Heat source setting
4. Password protection
5. Manual reset

Information on the other functions can be found by consulting the technical or service manuals.

### <General operation>

Many functions can not be set whilst the indoor unit is running. The installer should turn **OFF** the unit before trying to set these functions. If the installer attempts to change the settings whilst the unit is running the main controller will display a reminder message prompting the installer to stop operation before continuing. By selecting Yes the unit will cease operation and changes can be made to the service settings.

If text is displayed in white on a black background CONFIRM button must be pressed to save this choice.

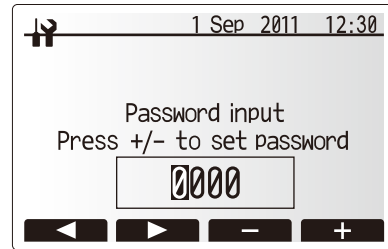

Screen 1 of service menu

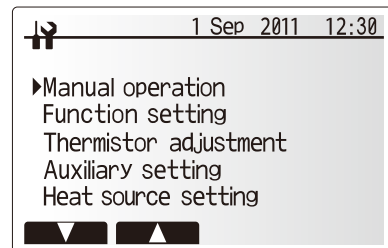

Screen 2 of service menu

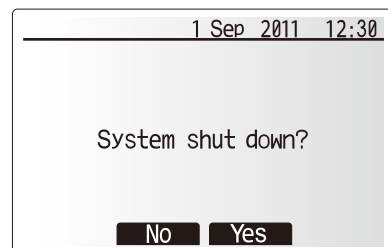

System off prompt screen



Action requires confirmation

Action is confirmed

## Auxiliary Setting

This function is used to set the parameters for any auxiliary parts used in the system.

From the service menu use F1 and F2 buttons to highlight Auxiliary setting then press CONFIRM.

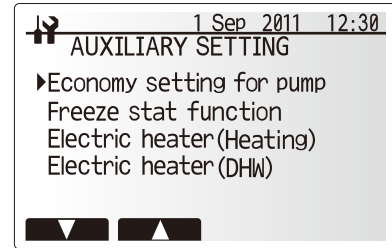

Auxiliary setting menu screen

### <Economy settings for pump>

1. From the Auxiliary setting menu highlight Economy Settings for pump.
2. Press CONFIRM.
3. The economy settings for pump screen will be displayed.
4. Use button F1 to switch the pump ON/OFF.
5. Use buttons F3 and F4 to adjust the time the pump will run. (3 - 60 mins)

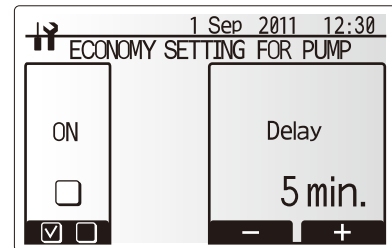

Economy settings for pump screen

### <Frost prevention>

1. From the Auxiliary setting menu highlight Freeze Stat Function.
2. Press CONFIRM.
3. The freeze stat function screen will be displayed.
4. Use buttons F3 and F4 to adjust the minimum outdoor temperature which freeze stat function will begin to operate, (3 - 20 °C) or choose \*.  
If asterisk (\*) is chosen freeze stat function is deactivated/disabled (i.e. freeze risk).

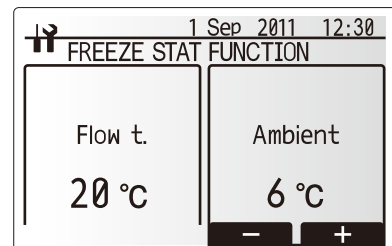

Freeze stat function screen

### <Electric heater (Heating)>

1. From the Auxiliary Setting menu highlight Electric heater (Heating).
2. Press CONFIRM.
3. The Electric heater (Heating) screen is displayed.
4. Press F1 button to switch the function ON/OFF.
5. Use F3 and F4 buttons to adjust the time period of Heat pump only operation before the booster heater will assist in space heating. (5 - 180mins)

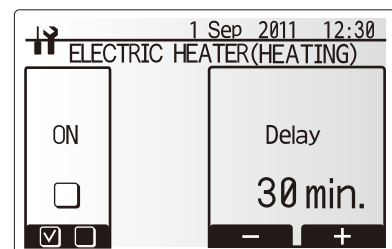

Electric heater (Heating) screen

### <Electric heater (DHW)>

1. From the Auxiliary Setting menu highlight Electric heater (DHW).
2. Press CONFIRM.
3. The Electric heater (DHW) screen is displayed.
4. Press F1 button to switch the function ON/OFF.
5. Use F3 and F4 buttons to adjust the time period of Heat pump only operation before the booster heater and the immersion heater (if present) will assist in DHW heating. (15 - 30mins)

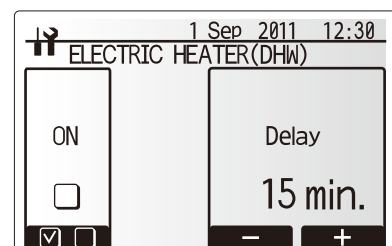

Electric heater (DHW) screen

**<Manual operation>**

During the filling of the system the pump and 3-way valve can be manually overridden using manual operation mode.

When manual operation is selected a small timer icon appears in the screen. The function selected will only remain in manual operation for a maximum of 2 hours. This is to prevent accidental permanent override of the FTC3.

1. From the service menu use F1 and F2 buttons to scroll through list until Manual Operation is highlighted.
2. Press CONFIRM.
3. Manual operation menu screen is displayed.
4. To activate manual operation press the function button under the desired part.
5. To return to service menu press MENU or BACK button.

**▶Example**

Pressing F3 button will switch manual operation mode ON for the main 3-way valve. When filling of the tank is complete the installer should access this menu again and press F3 to deactivate manual operation of the part. Alternatively after 2 hours manual operation mode will no longer be active and FTC3 will resume control of the part.

**NOTE:**

**Manual operation and heat source setting can not be selected if the system is running. A screen will be displayed asking the installer to stop the system before these modes can be activated.**

**The system automatically stops 2 hours after last operation.**

**The OUT13 output of the 2-way valve 2 constitutes an inversion of the OUT4 output of the 2-way valve 1.**

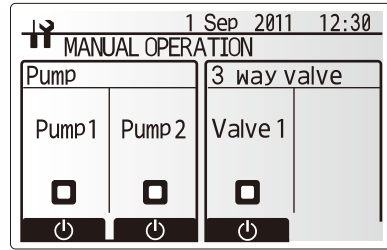

Manual operation menu screen

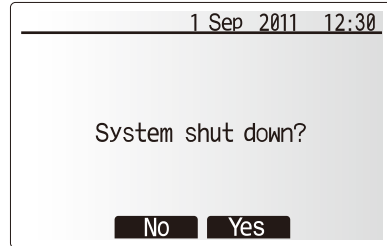

System off prompt screen

**<Function Setting>**

Function Setting allows the setting of auto recovery after power failure only.

1. From the service menu use F1 and F2 to highlight Function Setting.
  2. Press CONFIRM.
  3. Ensure the Ref address and unit number are displayed to the right.
  4. Press CONFIRM.
- NB Changes can ONLY be made to Mode 1.
6. Use F3 and F4 to highlight either 1/2/3 (see below).
  7. Press CONFIRM.

**Mode 1 Setting number meanings**

- 1 - Power failure automatic recovery NOT available
- 2 - Power failure automatic recovery AVAILABLE (Approx 4-minute delay after power is restored.)
- 3 - NO FUNCTION

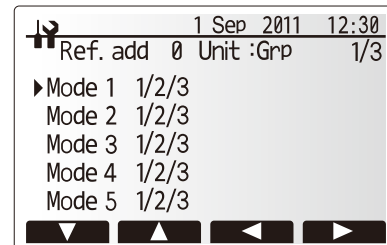
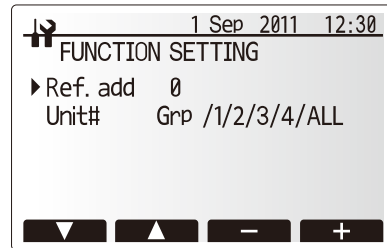

**<Thermistor Adjustment>**

This function allows adjustments to be made to the thermistor readings from -10 – 10 °C in 0.5 °C intervals.

1. From the Service menu highlight Thermistor Adjustment
2. Press CONFIRM.
3. Use F1 and F2 to select thermistor.
4. Press CONFIRM.
5. Use F2 and F3 to change the thermistor temperature.
6. Press CONFIRM.

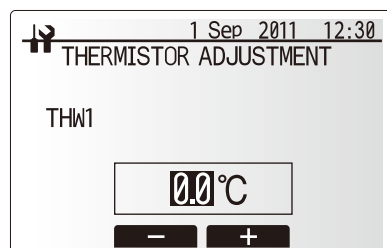
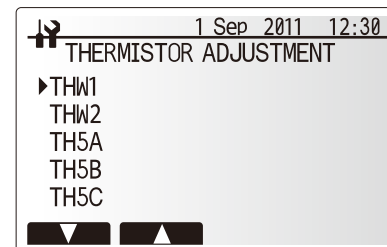

### <Heat source setting>

The default heat source setting is heat pump and all electric heaters present in the system to be operational. This is referred to as Standard operation on the menu.

1. From the service menu use F1 and F2 buttons to scroll through list until *Heat Source Setting* is highlighted.
2. Press CONFIRM.
3. Heat source setting menu screen is displayed.
4. Press F3 button until preferred heat source is displayed.
5. Press CONFIRM.
6. To return to service menu press MENU or BACK button.
7. If you wish to return to the service menu without saving the setting press return button. You will be asked if you are sure you wish to cancel the changes. Choose Yes or No as appropriate.

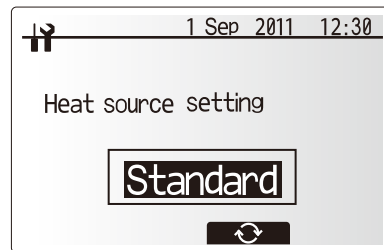

Heat source setting screen

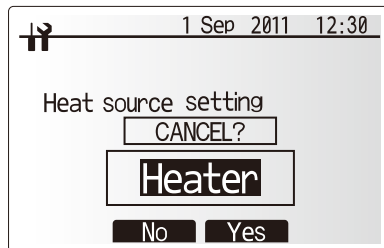

Cancel last action screen

### Operation Setting Menu

1. To access the Operation setting menu use F1 and F2 buttons to scroll through the service menu until Operation setting is highlighted.
2. Press CONFIRM.
3. Operation setting menu is displayed.

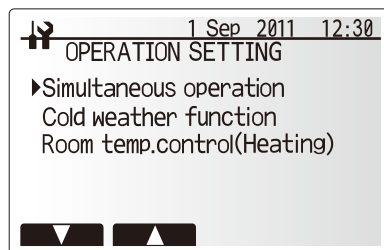

Operation setting menu screen

### <Simultaneous Operation>

For periods of very low outside temperature this mode can be used. Simultaneous operation allows both DHW and space heating to be provided simultaneously by using the heat pump to provide space heating whilst only the immersion heater (if fitted) provides heating for DHW. This operation is only available if BOTH a DHW tank AND immersion heater are present on the system.

1. From the Operation setting menu use F1 and F2 buttons to scroll through the list until Simultaneous operation is highlighted.
2. Press CONFIRM.
3. Simultaneous operation screen is displayed.
4. To switch simultaneous operation ON/OFF press F1.
5. To alter the temperature at which simultaneous operation starts use F3 and F4. Note: Range of ambient (outdoor) temperature is -15°C to 10°C (default -15°C).
6. To return to Operation setting menu press BACK.

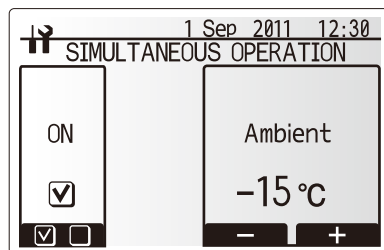

Simultaneous operation screen

### <Cold weather function>

For extremely low outdoor temperature conditions when the heat pump's capacity is severely restricted the heating or DHW is provided by only the electric booster heater (and immersion if present). This function is intended for use during extreme cold periods only. Extensive use of direct electrical heaters ONLY will result in higher electric usage and may reduce working life of heaters and related parts.

1. From the Operation setting menu use F1 and F2 buttons to scroll through the list until Cold weather function is highlighted.
2. Press CONFIRM.
3. Cold weather function screen is displayed.
4. To switch Cold weather function ON/OFF press F1.
5. To alter the temperature at which heater switching function starts use F3 and F4. Note: Range of ambient (outdoor) temperature is -15°C to -10°C (default -15°C).
6. To return to Operation setting menu press BACK.

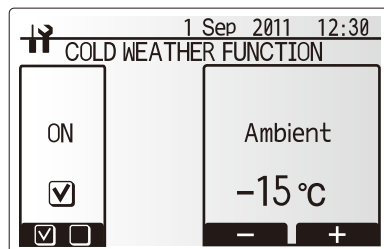

Cold weather function screen

### <Room Temp Control (Heating)>

This function allows operational setting of flow temperature range from the Eco-dan and also the time interval at which the FTC3 collects and processes data for the auto adaptation mode.

1. From the Operation setting menu use F1 and F2 buttons to scroll through the list until Room temp. control (HEATING) is highlighted.
2. Press CONFIRM.
3. Room temp. control (HEATING) screen is displayed.
4. To alter the time period at which data will be collected use F1 and F2 buttons to highlight 'Temp. control interval'.
5. Press CONFIRM.
6. Use F3 and F2 buttons to alter the time interval.
- Note: Range 10 – 60 minutes at 10 minute intervals (default 10 minutes).
7. To alter the flow temperature limits, use F1 and F2 buttons to highlight 'Flow temperature range'.
8. Press CONFIRM.
- Flow temperature range screen is displayed.
9. To alter minimum flow temp. use F1 and F2 buttons.
- Note: Range of minimum flow temp. is 25°C to 40°C (default 30°C).
10. To alter maximum flow temp. use F3 and F4 buttons.
- Note: Range of maximum flow temp. is 35°C to 60°C (default 50°C)
11. To return to Operation setting menu press BACK twice.

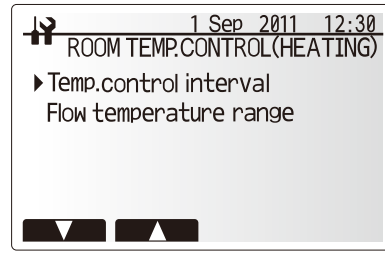

Room temp. control (HEATING) screen

### <Running Information>

This function shows current temperature and other data of main component parts of both the indoor and outdoor units.

1. From the Service menu highlight Running information.
2. Press CONFIRM.
3. Use the function buttons to enter index code for the component to be viewed.  
(See the Table 9-2-1 for component index codes.)
4. Press CONFIRM.

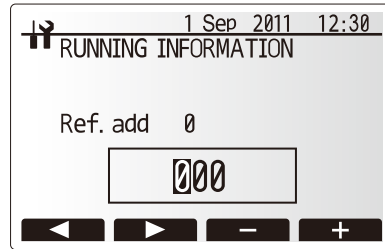

<Table 9-2-1>

Request code	Request content	Range	Unit
154	Indoor unit pump - Accumulated operating time (after reset)	0 - 9999	10 hours
162	Indoor unit - Dip SW1 setting information	Refer to detail contents described hereinafter	—
163	Indoor unit - Dip SW2 setting information	Refer to detail contents described hereinafter	—
164	Indoor unit - Dip SW3 setting information	Refer to detail contents described hereinafter	—
165	Indoor unit - Dip SW4 setting information	Refer to detail contents described hereinafter	—
175	Indoor unit - Output signal information	Refer to detail contents described hereinafter	—
176	Indoor unit - Input signal information	Refer to detail contents described hereinafter	—
190	Indoor unit - Software version 1st 4 digits	Refer to Note below	—
191	Indoor unit - Software version last 4 digits	Refer to Note below	—
340	Indoor unit pump - Accumulated operating time reset	—	—
512	Indoor unit - Booster heater temp. (THW3)	3 - 217	°C

#### Note

Refer to outdoor unit service manual for request code 0 to 149.

As only four digits can be displayed at one time the software version number is displayed in two halves.

Enter code 190 to see the first four digits and code 191 to see the last four digits.

For example software version No. 5.01 A000, when code 190 is entered 0501 is displayed, when code 191 is entered A000 is displayed.

<Thermistor reading> shows all the thermistor temperature except THW3.

**Indoor unit switch setting display (Request code: 162 to 165)**

0: OFF 1: ON

SW1, SW2, SW3, SW4								Display
1	2	3	4	5	6	7	8	
0	0	0	0	0	0	0	0	00 00
1	0	0	0	0	0	0	0	00 01
0	1	0	0	0	0	0	0	00 02
1	1	0	0	0	0	0	0	00 03
0	0	1	0	0	0	0	0	00 04
1	0	1	0	0	0	0	0	00 05
0	1	1	0	0	0	0	0	00 06
1	1	1	0	0	0	0	0	00 07
0	0	0	1	0	0	0	0	00 08
1	0	0	1	0	0	0	0	00 09
0	1	0	1	0	0	0	0	00 0A
1	1	0	1	0	0	0	0	00 0B
0	0	1	1	0	0	0	0	00 0C
1	0	1	1	0	0	0	0	00 0D
0	1	1	1	0	0	0	0	00 0E
1	1	1	1	0	0	0	0	00 0F
0	0	0	0	1	0	0	0	00 10
1	0	0	0	1	0	0	0	00 11
0	1	0	0	1	0	0	0	00 12
1	1	0	0	1	0	0	0	00 13
0	0	1	0	1	0	0	0	00 14
1	0	1	0	1	0	0	0	00 15
0	1	1	0	1	0	0	0	00 16
1	1	1	0	1	0	0	0	00 17
0	0	0	1	1	0	0	0	00 18
1	0	0	1	1	0	0	0	00 19
0	1	0	1	1	0	0	0	00 1A
1	1	0	1	1	0	0	0	00 1B
0	0	1	1	1	0	0	0	00 1C
1	0	1	1	1	0	0	0	00 1D
0	1	1	1	1	0	0	0	00 1E
1	1	1	1	1	0	0	0	00 1F
0	0	0	0	0	1	0	0	00 20
1	0	0	0	0	1	0	0	00 21
0	1	0	0	0	1	0	0	00 22
1	1	0	0	0	1	0	0	00 23
0	0	1	0	0	1	0	0	00 24
1	0	1	0	0	1	0	0	00 25
0	1	1	0	0	1	0	0	00 26
1	1	1	0	0	1	0	0	00 27
0	0	0	1	0	1	0	0	00 28
1	0	0	1	0	1	0	0	00 29
0	1	0	1	0	1	0	0	00 2A
1	1	0	1	0	1	0	0	00 2B
0	0	1	1	0	1	0	0	00 2C
1	0	1	1	0	1	0	0	00 2D
0	1	1	1	0	1	0	0	00 2E
1	1	1	1	0	1	0	0	00 2F
0	0	0	0	1	1	0	0	00 30
1	0	0	0	1	1	0	0	00 31
0	1	0	0	1	1	0	0	00 32
1	1	0	0	1	1	0	0	00 33
0	0	1	0	1	1	0	0	00 34
1	0	1	0	1	1	0	0	00 35
0	1	1	0	1	1	0	0	00 36
1	1	1	0	1	1	0	0	00 37
0	0	0	1	1	1	0	0	00 38
1	0	0	1	1	1	0	0	00 39
0	1	0	1	1	1	0	0	00 3A
1	1	0	1	1	1	0	0	00 3B
0	0	1	1	1	1	0	0	00 3C
1	0	1	1	1	1	0	0	00 3D
0	1	1	1	1	1	0	0	00 3E
1	1	1	1	1	1	0	0	00 3F

0: OFF 1: ON

SW1, SW2, SW3, SW4								Display
1	2	3	4	5	6	7	8	
0	0	0	0	0	0	1	0	00 40
1	0	0	0	0	0	1	0	00 41
0	1	0	0	0	0	1	0	00 42
1	1	0	0	0	0	1	0	00 43
0	0	1	0	0	0	1	0	00 44
1	0	1	0	0	0	1	0	00 45
0	1	1	0	0	0	1	0	00 46
1	1	1	0	0	0	1	0	00 47
0	0	0	1	0	0	1	0	00 48
1	0	0	1	0	0	1	0	00 49
0	1	0	1	0	0	1	0	00 4A
1	1	0	1	0	0	1	0	00 4B
0	0	1	1	0	0	1	0	00 4C
1	0	1	1	0	0	1	0	00 4D
0	1	1	1	0	0	1	0	00 4E
1	1	1	1	0	0	1	0	00 4F
0	0	0	0	1	0	1	0	00 50
1	0	0	0	1	0	1	0	00 51
0	1	0	0	1	0	1	0	00 52
1	1	0	0	1	0	1	0	00 53
0	0	1	0	1	0	1	0	00 54
1	0	1	0	1	0	1	0	00 55
0	1	1	0	1	0	1	0	00 56
1	1	1	0	1	0	1	0	00 57
0	0	0	1	1	0	1	0	00 58
1	0	0	1	1	0	1	0	00 59
0	1	0	1	1	0	1	0	00 5A
1	1	0	1	1	0	1	0	00 5B
0	0	1	1	1	0	1	0	00 5C
1	0	1	1	1	0	1	0	00 5D
0	1	1	1	1	0	1	0	00 5E
1	1	1	1	1	0	1	0	00 5F
0	0	0	0	0	1	1	0	00 60
1	0	0	0	0	1	1	0	00 61
0	1	0	0	0	1	1	0	00 62
1	1	0	0	0	1	1	0	00 63
0	0	1	0	0	1	1	0	00 64
1	0	1	0	0	1	1	0	00 65
0	1	1	0	0	1	1	0	00 66
1	1	1	0	0	1	1	0	00 67
0	0	0	1	0	1	1	0	00 68
1	0	0	1	0	1	1	0	00 69
0	1	0	1	0	1	1	0	00 6A
1	1	0	1	0	1	1	0	00 6B
0	0	1	1	0	1	1	0	00 6C
1	0	1	1	0	1	1	0	00 6D
0	1	1	1	0	1	1	0	00 6E
1	1	1	1	0	1	1	0	00 6F
0	0	0	0	1	1	1	0	00 70
1	0	0	0	1	1	1	0	00 71
0	1	0	0	1	1	1	0	00 72
1	1	0	0	1	1	1	0	00 73
0	0	1	0	1	1	1	0	00 74
1	0	1	0	1	1	1	0	00 75
0	1	1	0	1	1	1	0	00 76
1	1	1	0	1	1	1	0	00 77
0	0	0	1	1	1	1	0	00 78
1	0	0	1	1	1	1	0	00 79
0	1	0	1	1	1	1	0	00 7A
1	1	0	1	1	1	1	0	00 7B
0	0	1	1	1	1	1	0	00 7C
1	0	1	1	1	1	1	0	00 7D
0	1	1	1	1	1	1	0	00 7E
1	1	1	1	1	1	1	0	00 7F

**Indoor unit switch setting display (Request code: 162 to 165)**

0: OFF 1: ON

SW1, SW2, SW3, SW4								Display
1	2	3	4	5	6	7	8	
0	0	0	0	0	0	0	1	00 80
1	0	0	0	0	0	0	1	00 81
0	1	0	0	0	0	0	1	00 82
1	1	0	0	0	0	0	1	00 83
0	0	1	0	0	0	0	1	00 84
1	0	1	0	0	0	0	1	00 85
0	1	1	0	0	0	0	1	00 86
1	1	1	0	0	0	0	1	00 87
0	0	0	1	0	0	0	1	00 88
1	0	0	1	0	0	0	1	00 89
0	1	0	1	0	0	0	1	00 8A
1	1	0	1	0	0	0	1	00 8B
0	0	1	1	0	0	0	1	00 8C
1	0	1	1	0	0	0	1	00 8D
0	1	1	1	0	0	0	1	00 8E
1	1	1	1	0	0	0	1	00 8F
0	0	0	0	1	0	0	1	00 90
1	0	0	0	1	0	0	1	00 91
0	1	0	0	1	0	0	1	00 92
1	1	0	0	1	0	0	1	00 93
0	0	1	0	1	0	0	1	00 94
1	0	1	0	1	0	0	1	00 95
0	1	1	0	1	0	0	1	00 96
1	1	1	0	1	0	0	1	00 97
0	0	0	1	1	0	0	1	00 98
1	0	0	1	1	0	0	1	00 99
0	1	0	1	1	0	0	1	00 9A
1	1	0	1	1	0	0	1	00 9B
0	0	1	1	1	0	0	1	00 9C
1	0	1	1	1	0	0	1	00 9D
0	1	1	1	1	0	0	1	00 9E
1	1	1	1	1	0	0	1	00 9F
0	0	0	0	0	1	0	1	00 A0
1	0	0	0	0	1	0	1	00 A1
0	1	0	0	0	1	0	1	00 A2
1	1	0	0	0	1	0	1	00 A3
0	0	1	0	0	1	0	1	00 A4
1	0	1	0	0	1	0	1	00 A5
0	1	1	0	0	1	0	1	00 A6
1	1	1	0	0	1	0	1	00 A7
0	0	0	1	0	1	0	1	00 A8
1	0	0	1	0	1	0	1	00 A9
0	1	0	1	0	1	0	1	00 AA
1	1	0	1	0	1	0	1	00 AB
0	0	1	1	0	1	0	1	00 AC
1	0	1	1	0	1	0	1	00 AD
0	1	1	1	0	1	0	1	00 AE
1	1	1	1	0	1	0	1	00 AF
0	0	0	0	1	1	0	1	00 B0
1	0	0	0	1	1	0	1	00 B1
0	1	0	0	1	1	0	1	00 B2
1	1	0	0	1	1	0	1	00 B3
0	0	1	0	1	1	0	1	00 B4
1	0	1	0	1	1	0	1	00 B5
0	1	1	0	1	1	0	1	00 B6
1	1	1	0	1	1	0	1	00 B7
0	0	0	1	1	1	0	1	00 B8
1	0	0	1	1	1	0	1	00 B9
0	1	0	1	1	1	0	1	00 BA
1	1	0	1	1	1	0	1	00 BB
0	0	1	1	1	1	0	1	00 BC
1	0	1	1	1	1	0	1	00 BD
0	1	1	1	1	1	0	1	00 BE
1	1	1	1	1	1	0	1	00 BF

0: OFF 1: ON

SW1, SW2, SW3, SW4								Display
1	2	3	4	5	6	7	8	
0	0	0	0	0	0	1	1	00 C0
1	0	0	0	0	0	1	1	00 C1
0	1	0	0	0	0	1	1	00 C2
1	1	0	0	0	0	1	1	00 C3
0	0	1	0	0	0	1	1	00 C4
1	0	1	0	0	0	1	1	00 C5
0	1	1	0	0	0	1	1	00 C6
1	1	1	0	0	0	1	1	00 C7
0	0	0	1	0	0	1	1	00 C8
1	0	0	1	0	0	1	1	00 C9
0	1	0	1	0	0	1	1	00 CA
1	1	0	1	0	0	1	1	00 CB
0	0	1	1	0	0	1	1	00 CC
1	0	1	1	0	0	1	1	00 CD
0	1	1	1	0	0	1	1	00 CE
1	1	1	1	0	0	1	1	00 CF
0	0	0	0	1	0	1	1	00 D0
1	0	0	0	1	0	1	1	00 D1
0	1	0	0	1	0	1	1	00 D2
1	1	0	0	1	0	1	1	00 D3
0	0	1	0	1	0	1	1	00 D4
1	0	1	0	1	0	1	1	00 D5
0	1	1	0	1	0	1	1	00 D6
1	1	1	0	1	0	1	1	00 D7
0	0	0	1	1	0	1	1	00 D8
1	0	0	1	1	0	1	1	00 D9
0	1	0	1	1	0	1	1	00 DA
1	1	0	1	1	0	1	1	00 DB
0	0	1	1	1	0	1	1	00 DC
1	0	1	1	1	0	1	1	00 DD
0	1	1	1	1	0	1	1	00 DE
1	1	1	1	1	0	1	1	00 DF
0	0	0	0	0	1	1	1	00 E0
1	0	0	0	0	1	1	1	00 E1
0	1	0	0	0	1	1	1	00 E2
1	1	0	0	0	1	1	1	00 E3
0	0	1	0	0	1	1	1	00 E4
1	0	1	0	0	1	1	1	00 E5
0	1	1	0	0	1	1	1	00 E6
1	1	1	0	0	1	1	1	00 E7
0	0	0	1	0	1	1	1	00 E8
1	0	0	1	0	1	1	1	00 E9
0	1	0	1	0	1	1	1	00 EA
1	1	0	1	0	1	1	1	00 EB
0	0	1	1	0	1	1	1	00 EC
1	0	1	1	0	1	1	1	00 ED
0	1	1	1	0	1	1	1	00 EE
1	1	1	1	0	1	1	1	00 EF
0	0	0	0	1	1	1	1	00 F0
1	0	0	0	1	1	1	1	00 F1
0	1	0	0	1	1	1	1	00 F2
1	1	0	0	1	1	1	1	00 F3
0	0	1	0	1	1	1	1	00 F4
1	0	1	0	1	1	1	1	00 F5
0	1	1	0	1	1	1	1	00 F6
1	1	1	0	1	1	1	1	00 F7
0	0	0	1	1	1	1	1	00 F8
1	0	0	1	1	1	1	1	00 F9
0	1	0	1	1	1	1	1	00 FA
1	1	0	1	1	1	1	1	00 FB
0	0	1	1	1	1	1	1	00 FC
1	0	1	1	1	1	1	1	00 FD
0	1	1	1	1	1	1	1	00 FE
1	1	1	1	1	1	1	1	00 FF



**Output signal display (Request code: 175)**

Please refer to Table 2 on relevant wiring diagram whilst using the following.

0: OFF 1: ON

OUT								Display
1	2	3	4	5	6	7	8	
0	0	0	0	0	0	0	0	xx 00
1	0	0	0	0	0	0	0	xx 01
0	1	0	0	0	0	0	0	xx 02
1	1	0	0	0	0	0	0	xx 03
0	0	1	0	0	0	0	0	xx 04
1	0	1	0	0	0	0	0	xx 05
0	1	1	0	0	0	0	0	xx 06
1	1	1	0	0	0	0	0	xx 07
0	0	0	1	0	0	0	0	xx 08
1	0	0	1	0	0	0	0	xx 09
0	1	0	1	0	0	0	0	xx 0A
1	1	0	1	0	0	0	0	xx 0B
0	0	1	1	0	0	0	0	xx 0C
1	0	1	1	0	0	0	0	xx 0D
0	1	1	1	0	0	0	0	xx 0E
1	1	1	1	0	0	0	0	xx 0F
0	0	0	0	1	0	0	0	xx 10
1	0	0	0	1	0	0	0	xx 11
0	1	0	0	1	0	0	0	xx 12
1	1	0	0	1	0	0	0	xx 13
0	0	1	0	1	0	0	0	xx 14
1	0	1	0	1	0	0	0	xx 15
0	1	1	0	1	0	0	0	xx 16
1	1	1	0	1	0	0	0	xx 17
0	0	0	1	1	0	0	0	xx 18
1	0	0	1	1	0	0	0	xx 19
0	1	0	1	1	0	0	0	xx 1A
1	1	0	1	1	0	0	0	xx 1B
0	0	1	1	1	0	0	0	xx 1C
1	0	1	1	1	0	0	0	xx 1D
0	1	1	1	1	0	0	0	xx 1E
1	1	1	1	1	0	0	0	xx 1F
0	0	0	0	0	1	0	0	xx 20
1	0	0	0	0	1	0	0	xx 21
0	1	0	0	0	1	0	0	xx 22
1	1	0	0	0	1	0	0	xx 23
0	0	1	0	0	1	0	0	xx 24
1	0	1	0	0	1	0	0	xx 25
0	1	1	0	0	1	0	0	xx 26
1	1	1	0	0	1	0	0	xx 27
0	0	0	1	0	1	0	0	xx 28
1	0	0	1	0	1	0	0	xx 29
0	1	0	1	0	1	0	0	xx 2A
1	1	0	1	0	1	0	0	xx 2B
0	0	1	1	0	1	0	0	xx 2C
1	0	1	1	0	1	0	0	xx 2D
0	1	1	1	0	1	0	0	xx 2E
1	1	1	1	0	1	0	0	xx 2F
0	0	0	0	1	1	0	0	xx 30
1	0	0	0	1	1	0	0	xx 31
0	1	0	0	1	1	0	0	xx 32
1	1	0	0	1	1	0	0	xx 33
0	0	1	0	1	1	0	0	xx 34
1	0	1	0	1	1	0	0	xx 35
0	1	1	0	1	1	0	0	xx 36
1	1	1	0	1	1	0	0	xx 37
0	0	0	1	1	1	0	0	xx 38
1	0	0	1	1	1	0	0	xx 39
0	1	0	1	1	1	0	0	xx 3A
1	1	0	1	1	1	0	0	xx 3B
0	0	1	1	1	1	0	0	xx 3C
1	0	1	1	1	1	0	0	xx 3D
0	1	1	1	1	1	0	0	xx 3E
1	1	1	1	1	1	0	0	xx 3F

0: OFF 1: ON

OUT								Display
1	2	3	4	5	6	7	8	
0	0	0	0	0	0	1	0	xx 40
1	0	0	0	0	0	1	0	xx 41
0	1	0	0	0	0	1	0	xx 42
1	1	0	0	0	0	1	0	xx 43
0	0	1	0	0	0	1	0	xx 44
1	0	1	0	0	0	1	0	xx 45
0	1	1	0	0	0	1	0	xx 46
1	1	1	0	0	0	1	0	xx 47
0	0	0	1	0	0	1	0	xx 48
1	0	0	1	0	0	1	0	xx 49
0	1	0	1	0	0	1	0	xx 4A
1	1	0	1	0	0	1	0	xx 4B
0	0	1	1	0	0	1	0	xx 4C
1	0	1	1	0	0	1	0	xx 4D
0	1	1	1	0	0	1	0	xx 4E
1	1	1	1	0	0	1	0	xx 4F
0	0	0	0	1	0	1	0	xx 50
1	0	0	0	1	0	1	0	xx 51
0	1	0	0	1	0	1	0	xx 52
1	1	0	0	1	0	1	0	xx 53
0	0	1	0	1	0	1	0	xx 54
1	0	1	0	1	0	1	0	xx 55
0	1	1	0	1	0	1	0	xx 56
1	1	1	0	1	0	1	0	xx 57
0	0	0	1	1	0	1	0	xx 58
1	0	0	1	1	0	1	0	xx 59
0	1	0	1	1	0	1	0	xx 5A
1	1	0	1	1	0	1	0	xx 5B
0	0	1	1	1	0	1	0	xx 5C
1	0	1	1	1	0	1	0	xx 5D
0	1	1	1	1	0	1	0	xx 5E
1	1	1	1	1	0	1	0	xx 5F
0	0	0	0	0	1	1	0	xx 60
1	0	0	0	0	1	1	0	xx 61
0	1	0	0	0	1	1	0	xx 62
1	1	0	0	0	1	1	0	xx 63
0	0	1	0	0	1	1	0	xx 64
1	0	1	0	0	1	1	0	xx 65
0	1	1	0	0	1	1	0	xx 66
1	1	1	0	0	1	1	0	xx 67
0	0	0	1	0	1	1	0	xx 68
1	0	0	1	0	1	1	0	xx 69
0	1	0	1	0	1	1	0	xx 6A
1	1	0	1	0	1	1	0	xx 6B
0	0	1	1	0	1	1	0	xx 6C
1	0	1	1	0	1	1	0	xx 6D
0	1	1	1	0	1	1	0	xx 6E
1	1	1	1	0	1	1	0	xx 6F
0	0	0	0	1	1	1	0	xx 70
1	0	0	0	1	1	1	0	xx 71
0	1	0	0	1	1	1	0	xx 72
1	1	0	0	1	1	1	0	xx 73
0	0	1	0	1	1	1	0	xx 74
1	0	1	0	1	1	1	0	xx 75
0	1	1	0	1	1	1	0	xx 76
1	1	1	0	1	1	1	0	xx 77
0	0	0	1	1	1	1	0	xx 78
1	0	0	1	1	1	1	0	xx 79
0	1	0	1	1	1	1	0	xx 7A
1	1	0	1	1	1	1	0	xx 7B
0	0	1	1	1	1	1	0	xx 7C
1	0	1	1	1	1	1	0	xx 7D
0	1	1	1	1	1	1	0	xx 7E
1	1	1	1	1	1	1	0	xx 7F

**Indoor unit switch setting display (Request code: 175)**

Please refer to Table 2 on relevant wiring diagram whilst using the following.

0: OFF 1: ON

OUT								Display
1	2	3	4	5	6	7	8	
0	0	0	0	0	0	0	1	xx 80
1	0	0	0	0	0	0	1	xx 81
0	1	0	0	0	0	0	1	xx 82
1	1	0	0	0	0	0	1	xx 83
0	0	1	0	0	0	0	1	xx 84
1	0	1	0	0	0	0	1	xx 85
0	1	1	0	0	0	0	1	xx 86
1	1	1	0	0	0	0	1	xx 87
0	0	0	1	0	0	0	1	xx 88
1	0	0	1	0	0	0	1	xx 89
0	1	0	1	0	0	0	1	xx 8A
1	1	0	1	0	0	0	1	xx 8B
0	0	1	1	0	0	0	1	xx 8C
1	0	1	1	0	0	0	1	xx 8D
0	1	1	1	0	0	0	1	xx 8E
1	1	1	1	0	0	0	1	xx 8F
0	0	0	0	1	0	0	1	xx 90
1	0	0	0	1	0	0	1	xx 91
0	1	0	0	1	0	0	1	xx 92
1	1	0	0	1	0	0	1	xx 93
0	0	1	0	1	0	0	1	xx 94
1	0	1	0	1	0	0	1	xx 95
0	1	1	0	1	0	0	1	xx 96
1	1	1	0	1	0	0	1	xx 97
0	0	0	1	1	0	0	1	xx 98
1	0	0	1	1	0	0	1	xx 99
0	1	0	1	1	0	0	1	xx 9A
1	1	0	1	1	0	0	1	xx 9B
0	0	1	1	1	0	0	1	xx 9C
1	0	1	1	1	0	0	1	xx 9D
0	1	1	1	1	0	0	1	xx 9E
1	1	1	1	1	0	0	1	xx 9F
0	0	0	0	0	1	0	1	xx A0
1	0	0	0	0	1	0	1	xx A1
0	1	0	0	0	1	0	1	xx A2
1	1	0	0	0	1	0	1	xx A3
0	0	1	0	0	1	0	1	xx A4
1	0	1	0	0	1	0	1	xx A5
0	1	1	0	0	1	0	1	xx A6
1	1	1	0	0	1	0	1	xx A7
0	0	0	1	0	1	0	1	xx A8
1	0	0	1	0	1	0	1	xx A9
0	1	0	1	0	1	0	1	xx AA
1	1	0	1	0	1	0	1	xx AB
0	0	1	1	0	1	0	1	xx AC
1	0	1	1	0	1	0	1	xx AD
0	1	1	1	0	1	0	1	xx AE
1	1	1	1	0	1	0	1	xx AF
0	0	0	0	1	1	0	1	xx B0
1	0	0	0	1	1	0	1	xx B1
0	1	0	0	1	1	0	1	xx B2
1	1	0	0	1	1	0	1	xx B3
0	0	1	0	1	1	0	1	xx B4
1	0	1	0	1	1	0	1	xx B5
0	1	1	0	1	1	0	1	xx B6
1	1	1	0	1	1	0	1	xx B7
0	0	0	1	1	1	0	1	xx B8
1	0	0	1	1	1	0	1	xx B9
0	1	0	1	1	1	0	1	xx BA
1	1	0	1	1	1	0	1	xx BB
0	0	1	1	1	1	0	1	xx BC
1	0	1	1	1	1	0	1	xx BD
0	1	1	1	1	1	0	1	xx BE
1	1	1	1	1	1	0	1	xx BF

0: OFF 1: ON

OUT								Display
1	2	3	4	5	6	7	8	
0	0	0	0	0	0	1	1	xx C0
1	0	0	0	0	0	1	1	xx C1
0	1	0	0	0	0	1	1	xx C2
1	1	0	0	0	0	1	1	xx C3
0	0	1	0	0	0	1	1	xx C4
1	0	1	0	0	0	1	1	xx C5
0	1	1	0	0	0	1	1	xx C6
1	1	1	0	0	0	1	1	xx C7
0	0	0	1	0	0	1	1	xx C8
1	0	0	1	0	0	1	1	xx C9
0	1	0	1	0	0	1	1	xx CA
1	1	0	1	0	0	1	1	xx CB
0	0	1	1	0	0	1	1	xx CC
1	0	1	1	0	0	1	1	xx CD
0	1	1	1	0	0	1	1	xx CE
1	1	1	1	0	0	1	1	xx CF
0	0	0	0	1	0	1	1	xx D0
1	0	0	0	1	0	1	1	xx D1
0	1	0	0	1	0	1	1	xx D2
1	1	0	0	1	0	1	1	xx D3
0	0	1	0	1	0	1	1	xx D4
1	0	1	0	1	0	1	1	xx D5
0	1	1	0	1	0	1	1	xx D6
1	1	1	0	1	0	1	1	xx D7
0	0	0	1	1	0	1	1	xx D8
1	0	0	1	1	0	1	1	xx D9
0	1	0	1	1	0	1	1	xx DA
1	1	0	1	1	0	1	1	xx DB
0	0	1	1	1	0	1	1	xx DC
1	0	1	1	1	0	1	1	xx DD
0	1	1	1	1	0	1	1	xx DE
1	1	1	1	1	0	1	1	xx DF
0	0	0	0	0	1	1	1	xx E0
1	0	0	0	0	1	1	1	xx E1
0	1	0	0	0	1	1	1	xx E2
1	1	0	0	0	1	1	1	xx E3
0	0	1	0	0	1	1	1	xx E4
1	0	1	0	0	1	1	1	xx E5
0	1	1	0	0	1	1	1	xx E6
1	1	1	0	0	1	1	1	xx E7
0	0	0	1	0	1	1	1	xx E8
1	0	0	1	0	1	1	1	xx E9
0	1	0	1	0	1	1	1	xx EA
1	1	0	1	0	1	1	1	xx EB
0	0	1	1	0	1	1	1	xx EC
1	0	1	1	0	1	1	1	xx ED
0	1	1	1	0	1	1	1	xx EE
1	1	1	1	0	1	1	1	xx EF
0	0	0	0	1	1	1	1	xx F0
1	0	0	0	1	1	1	1	xx F1
0	1	0	0	1	1	1	1	xx F2
1	1	0	0	1	1	1	1	xx F3
0	0	1	0	1	1	1	1	xx F4
1	0	1	0	1	1	1	1	xx F5
0	1	1	0	1	1	1	1	xx F6
1	1	1	0	1	1	1	1	xx F7
0	0	0	1	1	1	1	1	xx F8
1	0	0	1	1	1	1	1	xx F9
0	1	0	1	1	1	1	1	xx FA
1	1	0	1	1	1	1	1	xx FB
0	0	1	1	1	1	1	1	xx FC
1	0	1	1	1	1	1	1	xx FD
0	1	1	1	1	1	1	1	xx FE
1	1	1	1	1	1	1	1	xx FF

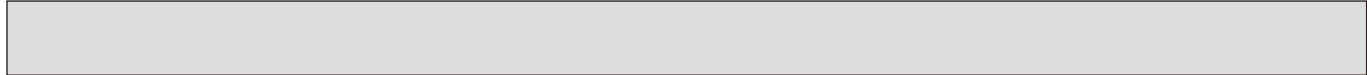

**Output signal display (Request code: 175)**

Please refer to Table 2 on relevant wiring diagram whilst using the following.

0: OFF 1: ON

OUT								Display
9	10	11	12	13	14	15	16	
0	0	0	0	0	0	0	0	00 xx
1	0	0	0	0	0	0	0	01 xx
0	1	0	0	0	0	0	0	02 xx
1	1	0	0	0	0	0	0	03 xx
0	0	1	0	0	0	0	0	04 xx
1	0	1	0	0	0	0	0	05 xx
0	1	1	0	0	0	0	0	06 xx
1	1	1	0	0	0	0	0	07 xx
0	0	0	1	0	0	0	0	08 xx
1	0	0	1	0	0	0	0	09 xx
0	1	0	1	0	0	0	0	0A xx
1	1	0	1	0	0	0	0	0B xx
0	0	1	1	0	0	0	0	0C xx
1	0	1	1	0	0	0	0	0D xx
0	1	1	1	0	0	0	0	0E xx
1	1	1	1	0	0	0	0	0F xx
0	0	0	0	1	0	0	0	10 xx
1	0	0	0	1	0	0	0	11 xx
0	1	0	0	1	0	0	0	12 xx
1	1	0	0	1	0	0	0	13 xx
0	0	1	0	1	0	0	0	14 xx
1	0	1	0	1	0	0	0	15 xx
0	1	1	0	1	0	0	0	16 xx
1	1	1	0	1	0	0	0	17 xx
0	0	0	1	1	0	0	0	18 xx
1	0	0	1	1	0	0	0	19 xx
0	1	0	1	1	0	0	0	1A xx
1	1	0	1	1	0	0	0	1B xx
0	0	1	1	1	0	0	0	1C xx
1	0	1	1	1	0	0	0	1D xx
0	1	1	1	1	0	0	0	1E xx
1	1	1	1	1	0	0	0	1F xx

**Input signal display (Request code: 176)**

Please refer to Table 1 on relevant wiring diagram whilst using the following.

0: OFF (open) 1: ON (short)

IN								Display
1	2	3	4	5	6	7	8	
0	0	0	0	0	0	0	0	00 00
1	0	0	0	0	0	0	0	00 01
0	1	0	0	0	0	0	0	00 02
1	1	0	0	0	0	0	0	00 03
0	0	1	0	0	0	0	0	00 04
1	0	1	0	0	0	0	0	00 05
0	1	1	0	0	0	0	0	00 06
1	1	1	0	0	0	0	0	00 07
0	0	0	1	0	0	0	0	00 08
1	0	0	1	0	0	0	0	00 09
0	1	0	1	0	0	0	0	00 0A
1	1	0	1	0	0	0	0	00 0B
0	0	1	1	0	0	0	0	00 0C
1	0	1	1	0	0	0	0	00 0D
0	1	1	1	0	0	0	0	00 0E
1	1	1	1	0	0	0	0	00 0F
0	0	0	0	1	0	0	0	00 10
1	0	0	0	1	0	0	0	00 11
0	1	0	0	1	0	0	0	00 12
1	1	0	0	1	0	0	0	00 13
0	0	1	0	1	0	0	0	00 14
1	0	1	0	1	0	0	0	00 15
0	1	1	0	1	0	0	0	00 16
1	1	1	0	1	0	0	0	00 17
0	0	0	1	1	0	0	0	00 18
1	0	0	1	1	0	0	0	00 19
0	1	0	1	1	0	0	0	00 1A
1	1	0	1	1	0	0	0	00 1B
0	0	1	1	1	0	0	0	00 1C
1	0	1	1	1	0	0	0	00 1D
0	1	1	1	1	0	0	0	00 1E
1	1	1	1	1	0	0	0	00 1F

**<Thermistor Reading>**

This function shows the current readings of thermistors located on the water and refrigerant circuit

Thermistor	Description
TH1	Room temperature
TH2	Refrigerant return temperature
THW1	Water flow temperature
THW2	Water return temperature
TH5A	—
TH5B	Tank temperature
TH5C	—
TH7	Ambient (outdoor) temperature

1 Sep 2010 12:30

**TH THERMISTOR READING**

TH1 0°C	TH5A 0°C
TH2 0°C	TH5B 0°C
THW1 0°C	TH5C 0°C
THW2 0°C	TH7 0°C

**UPDATE**

**<Summary of Settings>**

This function shows the current installer/user entered settings.

Abbreviation	Explanation	Abbreviation	Explanation
<b>HWtemp</b>	DHW max temp	<b>mode</b>	Operation mode
<b>HWdrop</b>	DHW temperature drop		- HER (Heating room temp)
<b>HWtime</b>	DHW max operation time		- HE (Heating flow temp)
<b>NO HW</b>	DHW mode restriction		- HCC (Heating compensation curve)
<b>HWset</b>	DHW operation mode (Normal/Eco)		- COR (—)
			- CO (—)
<b>Ltemp</b>	Legionella hot water temp	<b>Hroom</b>	Heating target room temp
<b>Lfreq</b>	Legionella operation Frequency	<b>Hflow</b>	Heating target flow temp
<b>Lstart</b>	Legionella mode start time	<b>Croom</b>	—
<b>Ltime</b>	Legionella max. operation time	<b>Cflow</b>	—
<b>Lkeep</b>	Duration of max (Legionella) hot water temp	<b>FSflow</b>	Freeze stat function flow temp
		<b>FSout</b>	Freeze stat function ambient temp

1 Sep 2010 12:30

**TH SUMMARY OF SETTING (1/2)**

HWtemp 30°C	Ltemp 60°C
HWdrop 30°C	Lfreq 15day
HWtime 10min	Lstart 3:00
NO HW 10min	Ltime 1h
HWset Normal	Lkeep 30min

**2/2**

1 Sep 2010 12:30

**TH SUMMARY OF SETTING (2/2)**

mode HER	FSflow 20°C
Hroom 0°C	FSout 10°C
Hflow 0°C	
Croom	
Cflow 0°C	

**1/2**

**<Error History>**

Error history allows the service engineer to view previous Error codes, the unit address and the date on which they occurred. Up to 16 Error codes can be stored in the history the most recent Error event is displayed at the top of the list.

1. From the service menu select Error history
  2. Press CONFIRM.
- Please see chapter 10-4. for error code diagnosis and actions.

To delete an Error history item;

1. From Error history screen press F4 button (Rubbish bin icon)
2. Then press F3 button (Yes).

1 Sep 2010 12:30

**TH ERROR HISTORY** 1/4

Error Unt# Date

---

1 Sep 2010 12:30

**TH ERROR HISTORY** 1/4

Error Unt# Date

---

E0	0-1	27/ 2/10	10:23AM
Delete OK?			
P8	0-1	1/ 2/10	4: 5PM
L7	0-1	31/ 1/10	12:54PM

**No Yes**

### <Password protection>

Password protection is available to prevent unauthorised access to the service menu by untrained persons.

1. From the service menu use F1 and F2 buttons to scroll through list until *Password protection* is highlighted.
2. Press CONFIRM.
3. When password input screen is displayed use buttons F1 and F2 to move left and right between the four digits, F3 to lower the selected digit by 1, and F4 to increase the selected digit by 1.
4. When you have input your password press CONFIRM.
5. The password verify screen is displayed.
6. To verify your new password press button F3.
7. Your password is now set and the completion screen is displayed.
8. To return to service menu press MENU or BACK button.



Password input screen

### <Resetting the password>

If you forget the password you entered, or have to service a unit somebody else installed, you can reset the password to the factory default of **0000**.

1. From the main settings menu scroll down the functions until Service Menu is highlighted.
2. Press CONFIRM.
3. You will be prompted to enter a password.
4. Hold down buttons F3 and F4 together for 3 secs.
5. You will be asked if you wish to continue and reset the password to default setting.
6. To reset press button F3.
7. The password is now reset to **0000**.



Password verify screen



Completion screen

### <Manual reset>

Should you wish to restore the factory settings at any time you should use the manual reset function. Please note this will reset ALL functions to the factory default settings.

1. From the service menu use F1 and F2 buttons to scroll through list until Manual Reset is highlighted.
2. Press CONFIRM.
3. The manual reset screen is displayed.
4. Choose either Manual Reset for FTC3 or main controller.
5. Press F3 button to confirm manual reset of chosen device.

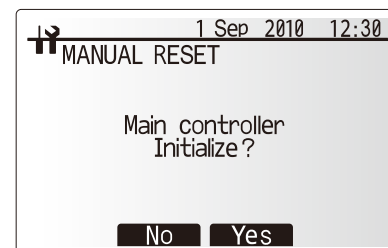
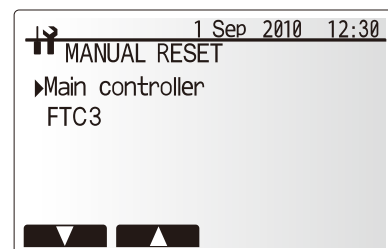

### <Emergency operation>

In Emergency operation mode the outdoor heat pump unit will not operate. Heating for DHW and space heating is provided by the booster heater and the tank immersion heater (if installed). Space heating flow temp is restricted 40°C if an immersion heater is not present on the DHW tank then the booster heater will also indirectly heat the DHW.

When in Emergency operation the main control has NO control functions. It's only function is to display the Main screen and Information screen by pressing F1, all other buttons are disabled.

#### • Activating Emergency operation mode

To activate Emergency operation see the following:

1. Switch OFF the breaker for the outdoor unit (or both breakers if cylinder powered independently).
2. Change DIP switch SW4-5 to ON.
3. Switch ON the breaker(s).
4. Emergency Operation is now activated.

#### • Deactivating Emergency operation mode

To deactivate Emergency operation see the following:

1. Switch OFF the breaker for the outdoor unit (or both breakers if cylinder powered independently).
2. Change DIP switch SW4-5 to OFF.
3. Switch ON the breaker(s).
4. Emergency operation is now deactivated.

#### ⚠ WARNING

Do not attempt to change the DIP switches whilst the breaker(s) are ON as this could result in ELECTROCUTION.

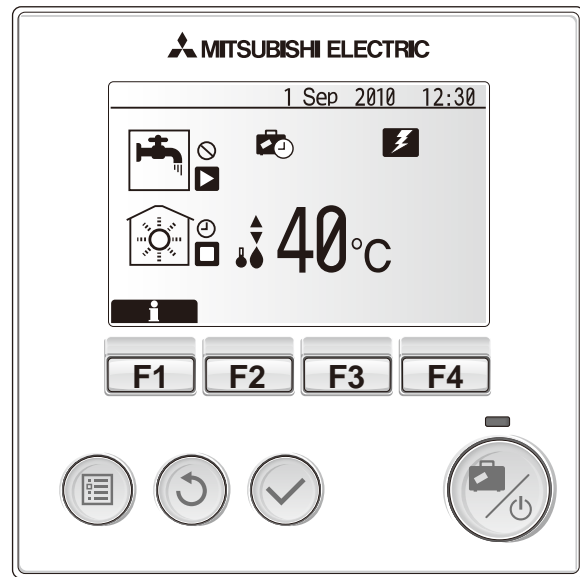

### 10-1. Troubleshooting

#### <Summary of self diagnosis based on Error Codes and Service Procedures>

Present and past Error codes are logged and displayed on the main controller or control board of the outdoor unit.

Please refer to the table below and subsequent explanations to diagnose and remedy typical problems that may occur in the field.

Unit Condition	Error Code	Action
Reoccurring problem	Displayed	Use table 10-4. "Self diagnosis and action" to identify fault and correct.
	Not Displayed	Use table 10-5. "Troubleshooting by inferior phenomena" to identify fault and correct.
Non reoccurring problem	Logged	1. Check temporary causes of defects such as the operation of safety devices on the refrigerant/water circuit including compressor, poor wiring, electrical noise etc. Re-check the symptom and the installation environment, refrigerant amount (Split systems only), weather conditions at time of fault etc. 2. Reset Error code logs, Service the unit and restart system.
	Not Logged	1. Recheck the abnormal symptom 2. Identify cause of problem and take corrective action according to Table 10-5. "Troubleshooting by inferior phenomena" 3. If no obvious problem can be found continue to operate the unit.

#### NOTE

Electrical components should only be replaced as a final option. Please follow instructions in Tables 10-4. and 10-5. Error Codes and Inferior Phenomena fully before resorting to replacing parts.

### 10-2. Test Run

Before a test run

- After installation of outdoor unit, pipework and electrical wiring, recheck that there is no water leakage, loosened connections or miswiring.
- Measure impedance between the ground and the power supply terminal block (L,N) on the outdoor and indoor units with suitable (500V) ohmmeter. Resistance should be  $\geq 1.0M\Omega$ .
- Read the Installation and Operation Manuals fully especially the safety requirements before carrying out any test runs.

### 10-3. Malfunction diagnosis method by main controller

If during start up or operation a malfunction occurs the error code screen may be displayed on the main controller.

The error code screen shows the following; code, unit, ref. address, and telephone number of installer (only if previously entered by the installer)

Please note in the case of some malfunctions an error code is not generated please refer to table 10-5. for more details.

To reset

1. To reset the main controller press F4 button (Reset).
2. Then press F3 (Yes) to confirm.

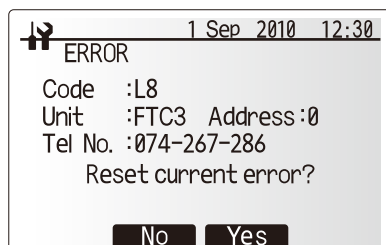
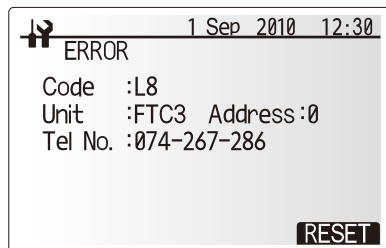

## 10-4. Self diagnosis and action

Check if Dip SW is set correctly. (Refer to Chapter 6-10.)

Error code	Title and display conditions	Possible Cause	Diagnosis and action
L1	<b>Booster heater overheat detection</b> <DHW/Heating/LP/FS/OS> Error code displayed when THW3 detects temp. of $\geq 85^{\circ}\text{C}$ for 10 consecutive seconds.  DHW : Domestic hot water mode Heating : Heating mode LP : Legionella prevention mode FS : Freeze stat OS : Operation stop TH1 : Room temp. thermistor TH2 : Liquid refrigerant temp. thermistor THW1 : Flow water temp. thermistor THW2 : Return water temp. thermistor THW3 : Booster heater temp. thermistor THW5B : Tank water temp. thermistor	① Insufficient system head	① Refer to table in section 10-6. to determine if system pump meets requirements. If more head required either add an pump of the same size or replace existing pump with capacity model. See 11. DISASSEMBLY PROCEDURE for how to replace pump.
		② Reduced flow in primary water circuit Due to 1 or more of the following; Faulty pump, insufficient air purge, blocked-strainer, leak in water circuit.	② Check circulation pump (See 10-6. for how to check). Open purge valve to remove trapped air. Check the strainer for blockages. Check the primary water circuit for leaks. Check that the flow amount is within the recommended range.
		③ Valve operation fault	③ Check valves on primary water circuit are installed level.
		④ 2-way valve (Locally supplied) actuator fault	④ Electrically test to determine fault.
		⑤ 3-way valve actuator fault	⑤ 1) Electrically test to determine fault. 2) Operate 3-way valve manually using the main remote controller. (Refer to <Manual operation> in 9.2). 3) Replace 3-way valve coil. 4) Replace 3-way valve. (Refer to Procedure 6 in "11. DISASSEMBLY PROCEDURE."
		⑥ Booster heater relay (BHC1, BHC2, BHCP) operating fault	⑥ Electrically test the relays (BHC1, BHC2, BHCP) to determine fault. See 10-6. for how to check
		⑦ Power supply voltage increase	⑦ Check the supply voltage.
		⑧ THW1 has become detached from its holder.	⑧ Visually inspect location and reattach as necessary.
		⑨ THW3 fault	⑨ Check resistance of thermistor against table in section 10-6. Compare FTC3 detected temperature to hand held detector.
		⑩ FTC3 board failure	⑩ Replace board.
L2	<b>Booster heater thermistor (THW3) failure</b> <DHW/Heating/LP/FS> Error code displayed when THW3 is at open ( $\leq 1.31^{\circ}\text{C}$ ) or short ( $\geq 219.42^{\circ}\text{C}$ ).  <u>Exceptions</u> Error code will not be displayed if; During defrost and 10 mins after defrost operation, For 10 mins after pump1 is switched on, When THW1 < 10deg.	① Connector/terminal wire has become detached or loose wiring.	① Visually check the terminals and connections and reattach as appropriate.
		② THW3 fault	② Check resistance of thermistor against table in section 10-6. Compare FTC3 detected temperature to hand held detector.
		③ FTC3 board failure	③ Replace board.





Error code	Title and display conditions	Possible Cause	Diagnosis and action																										
L3	<b>Circulation water temperature overheat protection</b> <DHW/Heating/LP/FS/OS> Error code displayed when THW1 detects a temp. $\geq 80^{\circ}\text{C}$ for 10 consecutive seconds or THW2 detects a temp $\geq 80^{\circ}\text{C}$ for 10 consecutive seconds.	① Insufficient system head	① Refer to table in section 10-6. to determine if system pump meets requirements. If more head required either add a pump of the same size or replace existing pump with capacity model. See 11. DISASSEMBLY PROCEDURE for how to replace pump.																										
		② Reduced flow in primary water circuit Due to 1 or more of the following; Faulty pump, insufficient air purge, blocked-strainer, leak in water circuit.	② Check circulation pump (See 10-6. for how to check). Open purge valve to remove trapped air. Check the strainer for blockages. Check the primary water circuit for leaks. Check that the flow amount is within the recommended range.																										
		③ Valve operation fault	③ Check valves on primary water circuit are installed level.																										
		④ 2-way valve (field supply) actuator fault	④ Electrically test to determine fault.																										
		⑤ 3-way valve actuator fault	⑤ 1) Electrically test to determine fault. 2) Operate 3-way valve manually using the main remote controller. (Refer to <Manual operation> in 9.2). 3) Replace 3-way valve coil. 4) Replace 3-way valve. (Refer to Procedure 6 in "11. DISASSEMBLY PROCEDURE."																										
		⑥ Booster heater relay (BHC1, BHC2, BHCP) operating fault	⑥ Electrically test the relays (BHC1, BHC2, BHCP) to determine fault. See 10-6. for how to check.																										
		⑦ Power supply voltage increase	⑦ Check the supply voltage.																										
		⑧ THW1 or THW3 or THW5B has become detached from its holder.	⑧ Visually inspect location and reattach as necessary.																										
		⑨ THW1 or THW2 fault	⑨ Check resistance of thermistor against table in section 10-6. Compare FTC3 detected temperature to hand held detector.																										
		⑩ FTC3 board failure	⑩ Replace board.																										
L4	<b>Tank water temperature overheat protection</b> <DHW/Heating/LP/FS/OS> Error code display when THW5B detects a temp. $\geq 75^{\circ}\text{C}$ for 10 consecutive seconds.	① 3-way valve actuator fault	① 1) Electrically test to determine fault. 2) Operate 3-way valve manually using the main remote controller. (Refer to <Manual operation> in 9.2). 3) Replace 3-way valve coil. 4) Replace 3-way valve. (Refer to Procedure 6 in "11. DISASSEMBLY PROCEDURE."																										
		② Immersion heater relay (IHC) operating fault	② Check immersion heater relay (IHC)																										
		③ THW5B fault	③ Check resistance of thermistor against table in section 10-6. Compare FTC3 detected temperature to hand held detector.																										
		④ FTC3 board failure	④ Replace board.																										
L5	<b>Indoor unit temperature thermistor (TH1, TH2, THW1, THW2, THW5B) failure</b> <DHW/Heating/LP/FS/OS> Error code displayed when thermistor is at open or short (see table).  <u>Exceptions</u> Error code will not be displayed for TH2; During defrost and for 10 mins after defrost operation.	① Connector/terminal wire has become detached or loose wiring.	① Visually check the terminals and connections and reattach as appropriate.																										
		② Thermistor fault	② Check resistance of thermistor against table in section 10-6. Compare FTC3 detected temperature to hand held detector.																										
		③ FTC3 board failure	③ Replace board.																										
		④ The thermistor on the wireless remote controller or the main remote controller may be defective. (when Room temp. is chosen for the Heating operation and when Main Controller or Room RC 1-8 is chosen for the Room Sensor setting in the Initial setting)	④ Replace wireless remote controller or main remote controller																										
		⑤ Incorrect setting of the Dip switch(es)	⑤ Check the Dip switch setting(s).																										
<table border="1"> <thead> <tr> <th colspan="2">Thermistor</th> <th rowspan="2">Open detection</th> <th rowspan="2">Short detection</th> </tr> <tr> <th>Symbol</th> <th>Name</th> </tr> </thead> <tbody> <tr> <td>TH1</td> <td>Room temperature thermistor</td> <td><math>-39^{\circ}\text{C}</math> or below</td> <td><math>88.5^{\circ}\text{C}</math> or above</td> </tr> <tr> <td>TH2</td> <td>Liquid temperature thermistor</td> <td><math>-39^{\circ}\text{C}</math> or below</td> <td><math>88.5^{\circ}\text{C}</math> or above</td> </tr> <tr> <td>THW1</td> <td>Flow water temperature thermistor</td> <td><math>-39^{\circ}\text{C}</math> or below</td> <td><math>88.5^{\circ}\text{C}</math> or above</td> </tr> <tr> <td>THW2</td> <td>Return water temperature thermistor</td> <td><math>-39^{\circ}\text{C}</math> or below</td> <td><math>88.5^{\circ}\text{C}</math> or above</td> </tr> <tr> <td>THW5B</td> <td>Tank water temperature thermistor</td> <td><math>-39^{\circ}\text{C}</math> or below</td> <td><math>88.5^{\circ}\text{C}</math> or above</td> </tr> </tbody> </table>				Thermistor		Open detection	Short detection	Symbol	Name	TH1	Room temperature thermistor	$-39^{\circ}\text{C}$ or below	$88.5^{\circ}\text{C}$ or above	TH2	Liquid temperature thermistor	$-39^{\circ}\text{C}$ or below	$88.5^{\circ}\text{C}$ or above	THW1	Flow water temperature thermistor	$-39^{\circ}\text{C}$ or below	$88.5^{\circ}\text{C}$ or above	THW2	Return water temperature thermistor	$-39^{\circ}\text{C}$ or below	$88.5^{\circ}\text{C}$ or above	THW5B	Tank water temperature thermistor	$-39^{\circ}\text{C}$ or below	$88.5^{\circ}\text{C}$ or above
Thermistor		Open detection	Short detection																										
Symbol	Name																												
TH1	Room temperature thermistor	$-39^{\circ}\text{C}$ or below	$88.5^{\circ}\text{C}$ or above																										
TH2	Liquid temperature thermistor	$-39^{\circ}\text{C}$ or below	$88.5^{\circ}\text{C}$ or above																										
THW1	Flow water temperature thermistor	$-39^{\circ}\text{C}$ or below	$88.5^{\circ}\text{C}$ or above																										
THW2	Return water temperature thermistor	$-39^{\circ}\text{C}$ or below	$88.5^{\circ}\text{C}$ or above																										
THW5B	Tank water temperature thermistor	$-39^{\circ}\text{C}$ or below	$88.5^{\circ}\text{C}$ or above																										

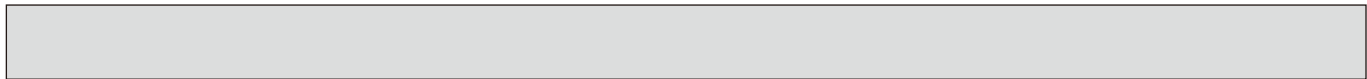

Error code	Title and display conditions	Possible Cause	Diagnosis and action
L6	<b>Circulation water freeze protection &lt;DHW/Heating/LP/FS/OS&gt;</b> Error code displayed when THW1 detects a temp. ≤ 1°C for 10 consecutive seconds or THW2 detects a temp. ≤ 3°C for 10 consecutive seconds.  <u>Exception</u> Error code will not be displayed if; FS function is disabled, For 10 mins after water circulation pump1 is switched on.	① Insufficient system head	① Refer to table in section 10-6. to determine if system pump meets requirements. If more head required either add an pump of the same size or replace existing pump with capacity model. See 11. DISASSEMBLY PROCEDURE for how to replace pump.
		② Reduced flow in primary water circuit. Due to 1 or more of the following; Faulty pump, insufficient air purge, blocked-strainer, leak in water circuit.	② Check circulation pump (See 10-6. for how to check). Open purge valve to remove trapped air. Check the strainer for blockages. Check the primary water circuit for leaks. Check that the flow amount is within the recommended range.
		③ Valve operation fault	③ Check valves on primary water circuit are installed level.
		④ 2-way valve (field supply) actuator fault	④ Electrically test to determine fault.
		⑤ 3-way valve actuator fault	⑤ 1) Electrically test to determine fault. 2) Operate 3-way valve manually using the main remote controller. (Refer to <Manual operation> in 9.2). 3) Replace 3-way valve coil. 4) Replace 3-way valve. (Refer to Procedure 6 in "11. DISASSEMBLY PROCEDURE."
		⑥ THW1 has become detached from its holder.	⑥ Visually inspect location and reattach as necessary.
		⑦ THW1 or THW2 fault	⑦ Check resistance of thermistor against table in section 10-6. Compare FTC3 detected temperature to hand held detector.
		⑧ FTC3 board failure	⑧ Replace board.
L7	<b>3-way valve failure (Valve direction defaults to DHW circuit) &lt;Heating/FS&gt;</b> If a) and b) occur, L7 is displayed; a) No change on THW1 (under 1 °C for 20 minutes from unit starts operation) b) THW5B goes up in Heating (or FS) mode. (over 1 °C for 20 minutes)  <u>Exception</u> If simultaneous Heating and DHW operation is selected error code will not be displayed.	① 3-way valve actuator fault	① 1) Electrically test to determine fault. 2) Operate 3-way valve manually using the main remote controller. (Refer to <Manual operation> in 9.2). 3) Replace 3-way valve coil. 4) Replace 3-way valve. (Refer to Procedure 6 in "11. DISASSEMBLY PROCEDURE."
		② THW1 or THW5B fault	② Check resistance of thermistor against table in section 10-6. Compare FTC3 detected temperature to hand held detector.
		③ FTC3 board failure The thermistor on the wireless remote controller or the main remote controller may be defective.	③ Replace board.
		④ Incorrect setting of the Dip switch(es)	④ Check the Dip switch setting(s)
		⑤ THW1 or THW5B has been detached from its holder.	⑤ Visually inspect location and reattach as necessary.
L8	<b>Heating operation error &lt;Heating/FS&gt;</b> If a), b) and c) occur, L8 is displayed; a) No change on THW1 and THW5B (under 1 °C for 20 minutes from unit starts operation) b) No change on THW1 (under 1 °C for 10 minutes from booster heater starts operation) c) THW1 - THW2 < -5 °C (for 10 minutes continuously)	① THW1 has become detached from its holder.	① Visually inspect location and reattach as necessary.
		② Booster heater fault	② Electrically test to determine fault. See 10-6. for how to check.
		③ THW1 or THW2 or THW5B fault	③ Check resistance of thermistor against table in section 10-6.  Compare FTC3 detected temperature to hand held detector.
		④ FTC3 board failure	④ Replace board.

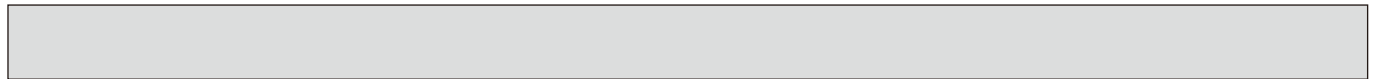

Error code	Title and display conditions	Possible Cause	Diagnosis and action
L9	<p><b>Low primary circuit flow rate detected by flow switch</b> &lt;DHW/Heating/LP/FS&gt; Error code displayed when flow switch detects low flow rate for 10 seconds.</p> <p><u>Exception</u> For 3 mins after water circulation pump1 is switched on.</p>	<p>① Insufficient system head</p> <p>② Reduced flow in primary water circuit Due to 1 or more of the following; Faulty pump, insufficient air purge, blocked strainer, leak in water circuit.</p> <p>③ Valve operation fault</p> <p>④ 2-way valve (field supply) actuator fault</p> <p>⑤ Connector/terminal wire has become detached or loose wiring.</p> <p>⑥ Flow switch fault</p> <p>⑦ FTC3 board failure Incorrect setting of SW2-2.</p> <p>⑧ Incorrect setting of the SW2-2</p>	<p>① Refer to table in section 10-6. to determine if system pump meets requirements. If more head required either add a pump of the same size or replace existing pump with capacity model. See 11. DISASSEMBLY PROCEDURE for how to replace pump.</p> <p>② Check circulation pump (See 10-6. for how to check). Open purge valve to remove trapped air. Check the strainer for blockages. Check the primary water circuit for leaks. Check that the flow amount is within the recommended range.</p> <p>③ Check valves on primary water circuit are installed level.</p> <p>④ Electrically test to determine fault.</p> <p>⑤ Visually check the CN2F connector and IN2 terminal and reattach if necessary.</p> <p>⑥ Electrically test to determine fault. See 10-6. for how to check.</p> <p>⑦ Replace board.</p> <p>⑧ Check the SW2-2 setting.</p>
E0/E4	<p><b>Main controller communication failure (Reception error)</b> Error code E0 is displayed if main controller does not receive any signal from the indoor unit for ref. address "0" for 3 mins. Error code E4 is displayed if indoor unit does not receive any data from the main controller for 3 mins or indoor unit does not receive any signal from the main controller for 2 mins.</p>	<p>① Contact failure with transmission cable</p> <p>② Wiring procedure not observed. (Cable length/cable diameter/number of indoor units/number of main controllers)</p> <p>③ Fault on the indoor unit FTC3 board section controlling Ref. address "0"</p> <p>④ Fault with the main controller circuit board</p> <p>⑤ Electrical noise causes interference with transmission/reception of data for main controller.</p>	<p>① Check connection cable for damage or loose connections at the FTC3 and main controller terminals.</p> <p>② Check main controller and FTC3 common wiring max cable length 500 m. Only use 2 core cable. Only connect 1 main controller to 1 FTC3 indoor unit board.</p> <p>③ to ⑤ If the problem is not solved by the above measures then: Turn the power to the indoor unit OFF and then ON. Power to both the indoor unit and outdoor units should be switched OFF then ON. (This may require switching 1 or 2 breakers depending if the unit is powered independently from the outdoor unit). If the E4 code is still displayed the FTC3 and/or the main controller circuit board should be replaced.</p>
E3/E5	<p><b>Main controller communication failure (Transmission error)</b> Error code E3 is displayed if the main controller an not find an empty transmission path and thus fails to transmit for 6 secs or the data received bythe main controller is different to what was sent (by the main controller) 30 consecutive times.</p> <p>Error code E5 is displayed if the FTC3 can not find an empty transmission path for 3 mins and thus cannot transmit or the data sent by the FTC3 is different to what was expected 30 consecutive times.</p>	<p>① 2 or more main controllers have been connected to the FTC3.</p> <p>② Fault with main controller transmission/receiving circuit board</p> <p>③ Fault with the main controller circuit board</p> <p>④ Electrical noise causes interference with transmission/reception of data for main controller.</p>	<p>① Only connect 1 main controller to 1 FTC3 indoor unit board.</p> <p>② to ④ Turn the power to the indoor unit OFF and then ON. Power to both the indoor unit and outdoor units should be switched OFF then ON. (This may require switching 1 or 2 breakers depending if the unit is powered independently from the outdoor unit). If the E3/E5 code is still displayed the FTC3 and/or the main controller circuit board should be replaced.</p>
E6	<p><b>Indoor/outdoor communication failure (Reception error)</b> Error code E6 is displayed if after the power is switched ON to the indoor unit, the FTC3 board does not receive any signal or the signal receivedis not complete for 6 mins, or after a period of operation the FTC3 board does not receive any signal or the signal received is not complete for 3 mins.</p>	<p>① Contact failure/short circuit/miswiring</p> <p>② Fault with outdoor unit transmission/receiving circuit board</p> <p>③ Fault with FTC3 transmission/receiving circuit board</p> <p>④ Electrical noise causes interference with FTC3-Outdoor unit transmission cable.</p>	<p>※ Check the LED display on the outdoor unit circuit board. (Connect the A-control service tool, PAC-SK52ST to test.) Refer to the outdoor unit service manual for explanation of EA-EC codes.</p> <p>① Check the connections on the indoor and outdoor units have not become loose and that the connecting cable is not damaged.</p> <p>② to ④ Turn the power to the indoor unit OFF and then ON. Power to both the indoor unit and outdoor units should be switched OFF then ON. (This may require switching 1 or 2 breakers depending if the unit is powered independently from the outdoor unit). If the E6 code is still displayed the FTC3 and/or the outdoor unit circuit board should be replaced.</p>



Error code	Title and display conditions	Possible Cause	Diagnosis and action
E7	<b>Indoor/outdoor communication failure (Transmission error)</b> Error code E7 is displayed if despite the FTC3 board sending signal "0", signal "1" is received 30 consecutive times.	① Fault with FTC3 transmission/receiving circuit board ② Electrical noise causes interference with power supply. ③ Electrical noise causes interference with FTC3-outdoor unit transmission cable.	① to ③ Turn the power to the indoor unit OFF and then ON. Power to both the indoor unit and outdoor units should be switched OFF then ON. (This may require switching 1 or 2 breakers depending if the unit is powered independently from the outdoor unit). If the E7 code is still displayed the FTC3 circuit board should be replaced.
E1/E2	<b>Main controller control board failure</b> Error code E1 displayed if main controller can not access it's non volatile (non power dependent) memory. Error code E2 is displayed when there is a fault with the main controller's internal clock.	① Fault with the main controller circuit board	① Replace main controller circuit board.
J0	<b>Indoor unit/wireless receiver communication failure</b> Error code J0 is displayed when the FTC3 can not receive data from the wireless receiver for 1 min.	① Connection fault with wireless receiver-FTC3 connection ② Fault with FTC3 receiving circuit board ③ Fault with wireless receiver's transmission circuit board ④ Electrical noise causes interference with wireless receiver communication cable.	① Check the connections to the wireless receiver and FTC3 have not become loose and that the connecting cable is not damaged. ② to ④ Turn the power to the indoor unit OFF and then ON. Power to both the indoor unit and outdoor units should be switched OFF then ON. (This may require switching 1 or 2 breakers depending if the unit is powered independently from the outdoor unit). If the J0 code is still displayed the FTC3 and/or the wireless receiver circuit board should be replaced.
J1 to J8	<b>Wireless remote controller/wireless receiver communication failure (Reception error)</b> Error code displayed if wireless receiver receives no/incomplete data from the wireless remote controller for 15 consecutive minutes.  The digit after the J refers to the address of the wireless remote controller that has the error. E.g. Error code "J3" refers to a communication fault between the wireless receiver and wireless remote control with address 3.	① Battery on wireless remote control may be flat  ② The wireless remote controller is out of range of the wireless receiver.  ③ Fault with wireless remote controller transmission circuit board  ④ Fault with wireless receiver's reception circuit board	① Check and replace the battery if necessary the wireless remote controller battery.  ② to ④ Reposition the wireless remote control closer to the receiver and perform a communication test. For procedure refer to wireless remote controller installation manual. If "OK" is displayed then the cause of the J1 to J8 error was the controller was out of range of the receiver. The wireless remote controller should be installed within range of the receiver. If "Err" is displayed replace wireless remote controller with a new controller and perform the pairing procedure. If after this procedure the "Err" code is still displayed the fault is with the receiver unit (attached to the indoor unit). The receiver unit should be replaced with a new part and the original remote control can be reconnected. If "OK" is displayed then the fault is with the remote control and this should be replaced.

Note: To cancel error codes please switch system off (press button F4 (RESET) on main controller).

## 10-5. Troubleshooting by inferior phenomena

No.	Fault symptom	Possible cause	Explanation - Solution
1	Main controller display does not work.	<ol style="list-style-type: none"> <li>There is no power supply to main controller.</li> <li>Power is supplied to main controller, however, the display on the main controller is not visible.</li> </ol>	<ol style="list-style-type: none"> <li>Check LED2 on FTC3.               <ol style="list-style-type: none"> <li>When LED2 is lit. Check the main controller wiring for damage or contact failure.</li> <li>When LED2 is blinking. Refer to No.5 below.</li> <li>When LED2 is not lit. Refer to No.4 below.</li> </ol> </li> <li>Check the following.               <ul style="list-style-type: none"> <li>Failure of main controller if "Please Wait" is not displayed.</li> <li>Refer to No.2 below if "Please Wait" is displayed.</li> </ul> </li> </ol>
2	"Please Wait" remains displayed on the main controller.	<ol style="list-style-type: none"> <li>"Please Wait" is displayed for up to 6 mins.</li> <li>Communication failure between the main controller and FTC3.</li> <li>Communication failure between FTC3 and outdoor unit.</li> </ol>	<ol style="list-style-type: none"> <li>Normal operation.</li> <li>3. Main controller start up checks/procedure.               <ol style="list-style-type: none"> <li>If main controller - FTC3 can not communicate the number displayed under "Please Wait" is 0%, or 50-99%.                   <ul style="list-style-type: none"> <li>Check wiring connections on main controller</li> <li>Replace main controller or FTC3 boards.</li> </ul> </li> <li>If 1-49% is displayed there is a communication error between the outdoor unit's and FTC3's boards.                   <ul style="list-style-type: none"> <li>Check the wiring connections on the outdoor unit and FTC3 boards. (Ensure S1, S2 are not cross wired and S3 is securely connected and not damaged.)</li> <li>Replace the outdoor unit's and/or the FTC3's boards.</li> </ul> </li> </ol> </li> </ol>
3	When pressing the "ON" button, the main screen is shown briefly then disappears.	If whilst changing the settings in the service menu, the system is shut down. When you return to the main screen you may have to wait a short while before the "ON" button will work.	Normal operation. The unit is processing the recent service menu changes and will be operational shortly.
4	LED2 on FTC3 is off.	<p>When LED1 on FTC3 is also off. &lt;FTC3 powered via outdoor unit.&gt;</p> <ol style="list-style-type: none"> <li>Power supply of rated voltage is not supplied to outdoor unit.</li> <li>Defective outdoor controller circuit board.</li> <li>Power supply of AC 220~240V is not supplied to FTC3.</li> <li>Defective FTC3.</li> <li>There are problems in the method of connecting the connectors.</li> </ol>	<ol style="list-style-type: none"> <li>Check the voltage of outdoor power supply terminal block (L,N) or (L3,N).               <ul style="list-style-type: none"> <li>When AC220~240V is not detected, check the power wiring to outdoor unit and the breaker.</li> <li>When AC 220~240V is detected, check 2 (below).</li> </ul> </li> <li>Check the voltage between outdoor terminal block S1 and S2.               <ul style="list-style-type: none"> <li>When AC 220~240V is not detected, check the fuse on outdoor controller circuit board, check the wiring connection.</li> <li>When AC 220~240V is detected, check 3 (below).</li> </ul> </li> <li>Check the voltage between indoor terminal block S1 and S2.               <ul style="list-style-type: none"> <li>When AC 220~240V is not detected, check FTC3/outdoor unit connecting wire for miswiring.</li> <li>When AC 220~240V is detected, check 4 (below).</li> </ul> </li> <li>Check the fuse on FTC3.               <ul style="list-style-type: none"> <li>Check the wiring connection.</li> </ul>               If no problems are found, FTC3 board is defective.             </li> <li>Check that there is no problem in the method of connecting the connectors.               <ul style="list-style-type: none"> <li>When there are problems in the method of connecting the connectors, connect the connector correctly referring to below.</li> </ul> </li> </ol>
		<p>&lt;FTC3 powered from independent source&gt;</p> <ol style="list-style-type: none"> <li>Power supply of AC 220~240V is not supplied to FTC3.</li> <li>There are problems in the method of connecting the connectors.</li> </ol>	<ol style="list-style-type: none"> <li>Check the voltage of indoor power supply terminal block (L,N).               <ul style="list-style-type: none"> <li>When AC220~240V is not detected, check the power supply wiring.</li> <li>When AC220~240V is detected, check 2 (below).</li> </ul> </li> <li>Check that there is no problem in the method of connecting the connectors.               <ul style="list-style-type: none"> <li>When there are problems in the method of connecting the connectors, connect the connector correctly referring to below.</li> </ul> </li> </ol>
		<p>When LED1 on FTC3 is lit. Miss-setting of refrigerant address for outdoor unit. (None of the refrigerant address is set to "0".)</p>	<p>Recheck the refrigerant address setting on the outdoor unit. Set the refrigerant address to "0". (Set refrigerant address using SW1(3-6) on outdoor controller circuit board.)</p>

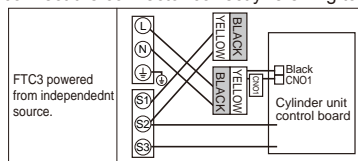
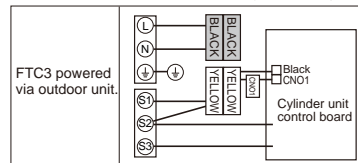

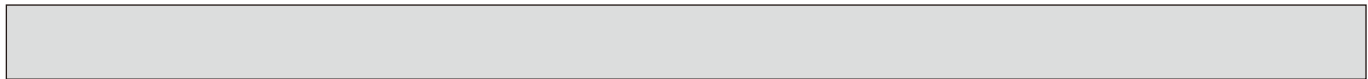

No.	Fault symptom	Possible cause	Explanation - Solution
5	LED2 on FTC3 is blinking.	<p>When LED1 on FTC3 is also blinking. Connection failure of FTC3/outdoor unit connecting wire</p> <p>When LED1 on FTC3 is lit.</p> <ol style="list-style-type: none"> <li>Miswiring of main controller wires Multiple indoor units have been wired to 1 outdoor unit.</li> <li>Miss-setting of refrigerant address for outdoor unit (Outdoor unit refrigerant address should be set to "0")</li> <li>Short-circuit of main controller wires</li> <li>Defective main controller</li> </ol>	<p>Check FTC3/outdoor unit connecting wire for connection failure.</p> <ol style="list-style-type: none"> <li>Check the connection of main controller wires. Only 1 indoor unit should be wired to 1 outdoor unit. Supplementary indoor units should each be wired to a separate outdoor unit.</li> <li>Recheck the refrigerant address setting on the outdoor unit. Set the refrigerant address to "0". (Set refrigerant address using SW1(3~6) on outdoor controller circuit board.)</li> <li, 4.="" <ul="" and="" check="" controller="" ftc3.="" led2="" main="" on="" remove="" wires=""> <li>If LED2 is blinking check the main controller wires are not short circuiting.</li> <li>If LED2 is lit, connect main controller wires again and: <ul style="list-style-type: none"> <li>- if LED2 is blinking, main controller is defective;</li> <li>- if LED2 is lit, connection failure of main controller terminal block etc. has returned to normal.</li> </ul> </li> </li,></ol>
6	No water at hot tap.	<ol style="list-style-type: none"> <li>Cold main off</li> <li>Strainer (field supply) blocked.</li> </ol>	<ol style="list-style-type: none"> <li>Check and open stop cock.</li> <li>Isolate water supply and clean strainer.</li> </ol>
7	Cold water at tap.	<ol style="list-style-type: none"> <li>All hot water used.</li> <li>Prohibit, schedule timer or holiday mode selected.</li> <li>Heat pump not working.</li> <li>Booster heater cut out has triggered.</li> <li>Booster heater breaker (ECB1) has tripped.</li> <li>The booster heater thermal cut-out has operated and can not be reset using the manual reset button.</li> <li>Immersion heater cut out has triggered.</li> <li>Immersion heater breaker (ECB2) has tripped.</li> <li>3-way valve fault</li> </ol>	<ol style="list-style-type: none"> <li>Ensure DHW mode is operating and wait for tank to re-heat.</li> <li>Check settings and change as appropriate.</li> <li>Check heat pump – consult outdoor unit service manual.</li> <li>Check booster heater thermostat and press reset button if safe. Reset button is covered with white rubber cap see component parts diagram section 10-6. for position.</li> <li>Check the cause of the trip and reset if safe.</li> <li>Check the resistance of the thermal cut out, if open then the connection is broken and the booster heater will have to be replaced. Please contact your Mitsubishi Electric dealer.</li> <li>Check immersion heater thermostat and press reset button, located on immersion heater boss, if safe. If the heater has been operated with no water inside it may have failed, so please replace it with a new one.</li> <li>Check the cause of the trip and reset if safe.</li> <li>Check plumbing/wiring to 3-way valve. <ol style="list-style-type: none"> <li>Operate 3-way valve manually using the main remote controller. (Refer to &lt;Manual operation&gt; in 9.2).</li> <li>Replace 3-way valve coil.</li> <li>Replace 3-way valve. (Refer to Procedure 6 in "11. DISASSEMBLY PROCEDURE."</li> </ol> </li> </ol>
8	It takes long for water to heat.	<ol style="list-style-type: none"> <li>Heat pump not working.</li> <li>Booster heater cut out has triggered.</li> <li>Booster heater breaker (ECB1) has tripped.</li> <li>The booster heater thermal cut-out has operated and can not be reset using the manual reset button.</li> <li>Immersion heater cut out has triggered.</li> <li>Immersion heater breaker (ECB2) has tripped.</li> </ol>	<ol style="list-style-type: none"> <li>Check heat pump – consult outdoor unit service manual.</li> <li>Check booster heater thermostat and press reset button if safe. Reset button is covered with white rubber cap see component parts diagram section 10-6. for position.</li> <li>Check the cause of the trip and reset if safe.</li> <li>Check the resistance of the thermal cut out, if open then the connection is broken and the booster heater will have to be replaced. Please contact your Mitsubishi Electric dealer.</li> <li>Check immersion heater thermostat and press reset button, located on immersion heater boss, if safe. If the heater has been operated with no water inside it may have failed, so please replace it with a new one.</li> <li>Check the cause of the trip and reset if safe.</li> </ol>
9	Water in tank is not used, but the water temperature of the tank decreases.	<p>The water temperature decreases to a certain degree as the tank heat radiates when DHW or Heating operation is not running. If the temperature decreases excessively and reheating occurs frequently, check for the following.</p> <ol style="list-style-type: none"> <li>Water leakage through the pipes that connect to the tank</li> <li>Peeling off of insulation</li> <li>3-way valve fault</li> </ol>	<ol style="list-style-type: none"> <li>Take the following measures. <ul style="list-style-type: none"> <li>Retighten the nuts holding the pipes onto the tank.</li> <li>Replace seal materials.</li> <li>Replace the pipes.</li> </ul> </li> <li>Reattach insulation.</li> <li>Check plumbing/wiring to 3-way valve. <ol style="list-style-type: none"> <li>Operate 3-way valve manually using the main remote controller. (Refer to &lt;Manual operation&gt; in 9.2).</li> <li>Replace 3-way valve coil.</li> <li>Replace 3-way valve. (Refer to Procedure 6 in "11. DISASSEMBLY PROCEDURE."</li> </ol> </li> </ol>
10	Hot or warm water from cold tap.	If tap runs cold after a minute or so the pipe is picking up heat from heating pipe work.	Insulate/re-route pipe work.





No.	Fault symptom	Possible cause	Explanation - Solution
12	Heating system does not get up to set temperature.	<ol style="list-style-type: none"> <li>1. Prohibit, schedule timer or holiday mode selected.</li> <li>2. Check settings and change as appropriate.</li> <li>3. The room in which the temperature sensor is located is at a different temperature to the rest of the house.</li> <li>4. Heat pump not working.</li> <li>5. Booster heater cut out has triggered.</li>   <li>6. Booster heater breaker (ECB1) has tripped.</li> <li>7. The booster heater thermal cut-out has operated and can not be reset using the manual reset button.</li>   <li>8. Incorrectly sized heat emitter.</li>   <li>9. 3-way valve fault</li>   <li>10. Battery problem *wireless control only</li> </ol>	<ol style="list-style-type: none"> <li>1. Check settings and change as appropriate.</li> <li>2. Check the battery power and replace if flat.</li> <li>3. Reposition the temperature sensor to a more suitable room.</li>   <li>4. Check heat pump – consult outdoor unit service manual.</li> <li>5. Check booster heater thermostat and press reset button if safe. Reset button is covered with white rubber cap see component parts diagram section 10-6. for position.</li> <li>6. Check the cause of the trip and reset if safe.</li> <li>7. Check the resistance of the thermal cut out, if 0 then the connection is broken and the booster heater will have to be replaced. Please contact your Mitsubishi Electric dealer.</li> <li>8. Check the heat emitter surface area is adequate Increase size if necessary.</li> <li>9. Check plumbing/wiring to 3-way valve. (i) Operate 3-way valve manually using the main remote controller. (Refer to &lt;Manual operation&gt; in 9.2). (ii) Replace 3-way valve coil. (iii) Replace 3-way valve. (Refer to Procedure 6 in “11. DISASSEMBLY PROCEDURE.”)</li> <li>10. Check the battery power and replace it flat.</li> </ol>
13	After DHW operation room temperature rises a little.	At the end of the DHW mode operation the 3-way valve diverts hot water away from the cylinder into space heating circuit. This is done to prevent the cylinder unit components from overheating. The amount of hot water directed into the space heating circuit is dependent on the type of system and the pipe run between the plate heat exchanger and the cylinder unit.	Normal operation no action necessary.
14	The room temperature rises during DHW operation.	3-way valve fault	<p>Check the 3-way valve.</p> <ol style="list-style-type: none"> <li>(i) Operate 3-way valve manually using the main remote controller. (Refer to &lt;Manual operation&gt; in 9.2.)</li> <li>(ii) Replace 3-way valve coil.</li> <li>(iii) Replace 3-way valve. (Refer to Procedure 6 in “11. DISASSEMBLY PROCEDURE.”)</li> </ol>
15	Water discharges from pressure relief valve. (Primary circuit)	<ol style="list-style-type: none"> <li>1. If continual – pressure relief valve seat may be damaged.</li> <li>2. If intermittent – expansion vessel charge may have reduced/bladder perished.</li> </ol>	<ol style="list-style-type: none"> <li>1. Remove cartridge – check seat and renew if necessary.</li> <li>2. Check pressure in expansion vessel. Recharge to 1 bar if necessary. If bladder perished replace vessel.</li> </ol>
16	Water discharges from pressure relief valve. (Sanitary circuit)	<ol style="list-style-type: none"> <li>1. If continual – field supplied pressure reducing valve not working.</li> <li>2. If continual – pressure relief valve seat may be damaged.</li> <li>3. If intermittent – expansion vessel charge may have reduced/bladder perished.</li> <li>4. Unit is being back pressurised.</li> </ol>	<ol style="list-style-type: none"> <li>1. Check function of pressure reducing valve and replace if necessary.</li> <li>2. Remove cartridge – check seat and renew if necessary.</li> <li>3. Check pressure in expansion vessel. Recharge to correct precharge pressure if necessary. If bladder perished replace vessel.</li> <li>4. With cylinder cold, check pressure in cylinder. If this is the same as the incoming mains pressure then you are getting back feed. Install a balanced cold supply.</li> </ol>
17	Water discharges from temperature and pressure relief valve (EHPT20X-VM2HA only) (Sanitary circuit)	<ol style="list-style-type: none"> <li>1. If continual – field supplied pressure reducing valve not working.</li> <li>2. If continual – pressure relief valve seat may be damaged.</li> <li>3. If intermittent – expansion vessel charge may have reduced/bladder perished.</li> <li>4. Unit is being back pressurised.</li>   <li>5. Unit has overheated – thermal controls have failed.</li> </ol>	<ol style="list-style-type: none"> <li>1. Check function of pressure reducing valve and replace if necessary.</li> <li>2. Remove cartridge – check seat and renew if necessary.</li> <li>3. Check pressure in expansion vessel. Recharge to correct precharge pressure if necessary. If bladder perished replace vessel.</li> <li>4. With cylinder cold, check pressure in cylinder. If this is the same as the incoming mains pressure then you are getting back feed. Install a balanced cold supply.</li> <li>5. Switch off power to the heat pump and immersion heaters. Leave water supply on. Wait until discharge stops. Isolate water supply and replace if faulty.</li> </ol>
18	Noisy pump	Air in pump.	Use manual and automatic air vents to remove air from system. Top up water if necessary to achieve 1bar on primary circuit.
19	Noise during hot water draw off typically worse in the morning.	Loose airing cupboard pipework. Heaters switching on/off.	Install extra pipe fastening clips.
20	Mechanical noise heard coming from the cylinder unit.	<ol style="list-style-type: none"> <li>1. Heaters switching on/off.</li> <li>2. 3-way valve changing position between DHW and heating mode.</li> </ol>	Normal operation no action necessary.
21	Pump runs for a short time for no reason.	Pump jam prevention mechanism to inhibit the build up of scale.	Normal operation no action necessary.
22	Milky/Cloudy water (Sanitary circuit)	Oxygenated water	Water from any pressurised system will release oxygen bubbles when flowing. The bubbles will settle out.



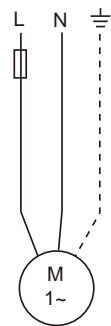
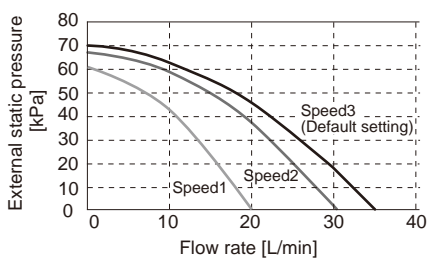
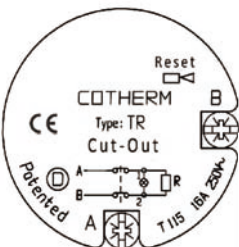

No.	Fault symptom	Possible cause	Explanation - Solution
23	Heating mode has been on standby for a long time (does not start operation smoothly.)	Duration is set to excessively short time at "Economy setting for pump". (Go to "Service menu" → "Auxiliary setting" → "Economy setting for pump").	Set "Economy setting for pump" longer.
24	Heating emitter is hot in the DHW mode. (The room temperature rises.)	The 3-way valve may have foreign objects in it, or hot water may flow to the heating side due to malfunctions.	Manually override the 3-way valve several times to check whether the problem will be solved. (Refer to the service manual.) If the problem persists replace the 3-way valve coil with a new one. If still no change replace the entire 3-way valve with a new one.
25	The cylinder unit that was running in the heating mode before power failure is running in the DHW mode after power recovery.	The cylinder unit is designed to run in an operation mode with a higher priority (i.e. DHW mode in this case) at power recovery.	<ul style="list-style-type: none"> <li>• Normal operation.</li> <li>• After the DHW max. operation time has elapsed or the DHW max. temperature has been reached, the DHW mode switches to the other mode (ex. Heating mode).</li> </ul>

### 10-6. Checking Component Parts' Function

Part Name	Check Points																																	
<p><u>Water circulation pump</u></p> 	<p>Measure the resistance between the terminals with a tester. (Winding temperature 20 °C)</p> <table border="1"> <thead> <tr> <th>Terminal</th> <th>Normal</th> <th>Abnormal</th> </tr> </thead> <tbody> <tr> <td>L - N</td> <td>121Ω</td> <td>Open or Short</td> </tr> </tbody> </table> <p><b>&lt;Water circulation pump characteristics&gt;</b></p>  <p><b>&lt;Recommended water flow rate range&gt;</b></p> <table border="1"> <thead> <tr> <th colspan="2">Outdoor heat pump unit</th> <th>Water flow rate range [L/min]</th> </tr> </thead> <tbody> <tr> <td rowspan="4">Packaged</td> <td>PUHZ-W50</td> <td>7.1 - 14.3</td> </tr> <tr> <td>PUHZ-W85</td> <td>10.0 - 25.8</td> </tr> <tr> <td>PUHZ-HW112</td> <td>14.4 - 27.7</td> </tr> <tr> <td>PUHZ-HW140</td> <td>17.9 - 27.7</td> </tr> <tr> <td rowspan="7">Split</td> <td>PUHZ-RP35</td> <td>7.1 - 11.8</td> </tr> <tr> <td>PUHZ-RP50</td> <td>7.1 - 17.2</td> </tr> <tr> <td>PUHZ-RP60</td> <td>8.6 - 20.1</td> </tr> <tr> <td>PUHZ-(H)RP71</td> <td>10.2 - 22.9</td> </tr> <tr> <td>PUHZ-(H)RP100</td> <td>14.4 - 27.7</td> </tr> <tr> <td>PUHZ-(H)RP125</td> <td>17.9 - 27.7</td> </tr> <tr> <td>PUHZ-RP140</td> <td>20.1 - 27.7</td> </tr> </tbody> </table> <p>* If the water flow rate is less than 7.1 L/min, the flow switch will be activated. If the water flow rate exceeds 27.7 L/min, the flow speed will be greater than 1.5 m/s, which could corrode the pipes.</p>	Terminal	Normal	Abnormal	L - N	121Ω	Open or Short	Outdoor heat pump unit		Water flow rate range [L/min]	Packaged	PUHZ-W50	7.1 - 14.3	PUHZ-W85	10.0 - 25.8	PUHZ-HW112	14.4 - 27.7	PUHZ-HW140	17.9 - 27.7	Split	PUHZ-RP35	7.1 - 11.8	PUHZ-RP50	7.1 - 17.2	PUHZ-RP60	8.6 - 20.1	PUHZ-(H)RP71	10.2 - 22.9	PUHZ-(H)RP100	14.4 - 27.7	PUHZ-(H)RP125	17.9 - 27.7	PUHZ-RP140	20.1 - 27.7
Terminal	Normal	Abnormal																																
L - N	121Ω	Open or Short																																
Outdoor heat pump unit		Water flow rate range [L/min]																																
Packaged	PUHZ-W50	7.1 - 14.3																																
	PUHZ-W85	10.0 - 25.8																																
	PUHZ-HW112	14.4 - 27.7																																
	PUHZ-HW140	17.9 - 27.7																																
Split	PUHZ-RP35	7.1 - 11.8																																
	PUHZ-RP50	7.1 - 17.2																																
	PUHZ-RP60	8.6 - 20.1																																
	PUHZ-(H)RP71	10.2 - 22.9																																
	PUHZ-(H)RP100	14.4 - 27.7																																
	PUHZ-(H)RP125	17.9 - 27.7																																
	PUHZ-RP140	20.1 - 27.7																																
<p><u>Immersion heater</u></p> 	<p>Measure the resistance between the terminals with a tester. (Winding temperature 20°C)</p> <table border="1"> <thead> <tr> <th>Terminal</th> <th>Normal</th> <th>Abnormal</th> </tr> </thead> <tbody> <tr> <td>A-B</td> <td>19.2 Ω</td> <td>Open or Short</td> </tr> </tbody> </table> <p>To reset the immersion heater use a pin or similar to press the reset button located on the top of the immersion boss. See diagram on the left.</p>	Terminal	Normal	Abnormal	A-B	19.2 Ω	Open or Short																											
Terminal	Normal	Abnormal																																
A-B	19.2 Ω	Open or Short																																

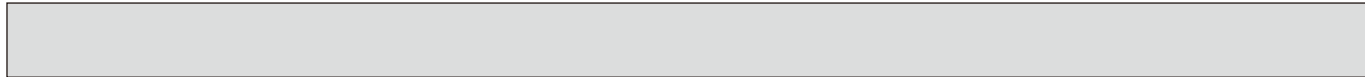

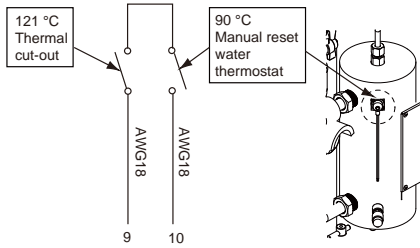

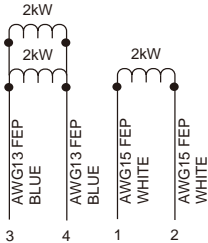
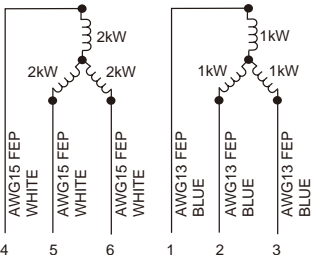
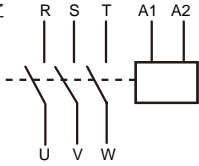
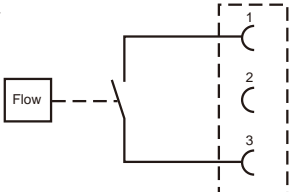
Part Name	Check Points													
<p><b>Booster heater</b> Thermostat (90 °C) and thermal cut out (121 °C)</p> 	<p>Measure the resistance between the terminals with a tester.</p> <table border="1" data-bbox="707 327 1323 383"> <thead> <tr> <th>Terminal</th> <th>Normal</th> <th>Abnormal</th> </tr> </thead> <tbody> <tr> <td>9-10</td> <td>110(±35)mΩ</td> <td>Open or Short</td> </tr> </tbody> </table>	Terminal	Normal	Abnormal	9-10	110(±35)mΩ	Open or Short							
Terminal	Normal	Abnormal												
9-10	110(±35)mΩ	Open or Short												
<p>2kW heater (230V, 1 phase)</p> 	<table border="1" data-bbox="707 613 1323 669"> <thead> <tr> <th>Terminal</th> <th>Normal</th> <th>Abnormal</th> </tr> </thead> <tbody> <tr> <td>1-2</td> <td>26.5(+3/-1.3)Ω</td> <td>Open or Short</td> </tr> </tbody> </table>	Terminal	Normal	Abnormal	1-2	26.5(+3/-1.3)Ω	Open or Short							
Terminal	Normal	Abnormal												
1-2	26.5(+3/-1.3)Ω	Open or Short												
<p>2 + 4kW heater (230V, 1 phase)</p> 	<table border="1" data-bbox="707 855 1323 936"> <thead> <tr> <th>Terminal</th> <th>Normal</th> <th>Abnormal</th> </tr> </thead> <tbody> <tr> <td>1-2</td> <td>26.5(+3/-1.3)Ω</td> <td>Open or Short</td> </tr> <tr> <td>3-4</td> <td>13.3(+1.5/-0.6)Ω</td> <td>Open or Short</td> </tr> </tbody> </table>	Terminal	Normal	Abnormal	1-2	26.5(+3/-1.3)Ω	Open or Short	3-4	13.3(+1.5/-0.6)Ω	Open or Short				
Terminal	Normal	Abnormal												
1-2	26.5(+3/-1.3)Ω	Open or Short												
3-4	13.3(+1.5/-0.6)Ω	Open or Short												
<p>3 + 6kW heater (400V, 3 phase)</p> 	<table border="1" data-bbox="707 1149 1323 1229"> <thead> <tr> <th>Terminal</th> <th>Normal</th> <th>Abnormal</th> </tr> </thead> <tbody> <tr> <td>1-2=2-3=1-3</td> <td>105.8(+11.8/-5)Ω</td> <td>Open or Short</td> </tr> <tr> <td>4-5=5-6=4-6</td> <td>52.9(+5.8/-2.5)Ω</td> <td>Open or Short</td> </tr> </tbody> </table>	Terminal	Normal	Abnormal	1-2=2-3=1-3	105.8(+11.8/-5)Ω	Open or Short	4-5=5-6=4-6	52.9(+5.8/-2.5)Ω	Open or Short				
Terminal	Normal	Abnormal												
1-2=2-3=1-3	105.8(+11.8/-5)Ω	Open or Short												
4-5=5-6=4-6	52.9(+5.8/-2.5)Ω	Open or Short												
<p><b>Earth leakage breaker for heater</b></p>	<p>If a short circuit occurs on the booster heater, immersion heater, or each power line, a short-circuit breaker will trip and power source will be blocked. Eliminate the causes of short circuit and then turn on the breaker again.</p>													
<p><b>Relay for heater</b></p> 	<p>When the applied voltage is not 230V AC across the terminals A1-A2, check the terminals R-U, S-V, and T-W are open. When the applied voltage is 230V AC across the terminals A1-A2, check the terminals R-U, S-V, and T-W are short.</p>													
<p><b>Flow switch</b></p> 	<p>Measure the resistance between the terminals with a tester.</p> <table border="1" data-bbox="707 1738 1482 1832"> <thead> <tr> <th>State of moving part</th> <th>Normal</th> <th>Abnormal</th> </tr> </thead> <tbody> <tr> <td>Paddle vertical (Flow &lt; 5.5 l/min)</td> <td>Open</td> <td>Other than open</td> </tr> <tr> <td>Paddle inclined (Flow &gt; 5.5 l/min)</td> <td>Short</td> <td>Other than short</td> </tr> </tbody> </table>	State of moving part	Normal	Abnormal	Paddle vertical (Flow < 5.5 l/min)	Open	Other than open	Paddle inclined (Flow > 5.5 l/min)	Short	Other than short				
State of moving part	Normal	Abnormal												
Paddle vertical (Flow < 5.5 l/min)	Open	Other than open												
Paddle inclined (Flow > 5.5 l/min)	Short	Other than short												
<p><b>Thermistors</b></p>	<p>Disconnect the connector then measure the resistance with a tester. (At ambient temperatures of 10 - 30°C.)</p> <table border="1" data-bbox="707 1955 1291 2141"> <thead> <tr> <th>Thermistor</th> <th>Normal</th> <th>Abnormal</th> </tr> </thead> <tbody> <tr> <td>TH1</td> <td rowspan="5">4.3 - 9.5 kΩ</td> <td rowspan="5">Open or short</td> </tr> <tr> <td>TH2</td> </tr> <tr> <td>THW1</td> </tr> <tr> <td>THW2</td> </tr> <tr> <td>THW5B</td> </tr> <tr> <td>THW3</td> <td>160 - 410 kΩ</td> <td></td> </tr> </tbody> </table>	Thermistor	Normal	Abnormal	TH1	4.3 - 9.5 kΩ	Open or short	TH2	THW1	THW2	THW5B	THW3	160 - 410 kΩ	
Thermistor	Normal	Abnormal												
TH1	4.3 - 9.5 kΩ	Open or short												
TH2														
THW1														
THW2														
THW5B														
THW3	160 - 410 kΩ													

<Thermistor Characteristics Charts>

- Room temperature thermistor (TH1)
- Liquid refrigerant temperature thermistor (TH2)
- Flow water temperature thermistor (THW1)
- Return water temperature thermistor (THW2)
- DHW tank temperature thermistor (THW5B)

Thermistor R0 = 15kΩ ± 3%  
 B constant = 3480 ± 2%

$$R_t = 15 \exp \left\{ 3480 \left( \frac{1}{273+t} - \frac{1}{273} \right) \right\}$$

0°C	15kΩ
10°C	9.6kΩ
20°C	6.3kΩ
25°C	5.2kΩ
30°C	4.3kΩ
40°C	3.0kΩ

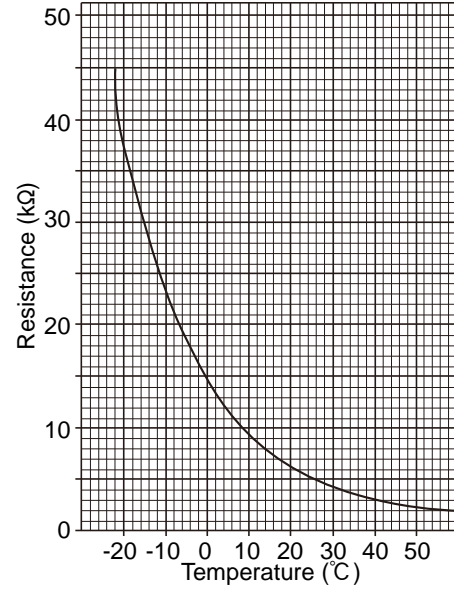

- Booster heater temperature thermistor (THW3)

Thermistor R120 = 7.465kΩ ± 2%  
 B constant = 4057 ± 2%

$$R_t = 7.465 \exp \left\{ 4057 \left( \frac{1}{273+t} - \frac{1}{393} \right) \right\}$$

20°C	250kΩ	70°C	34kΩ
30°C	160kΩ	80°C	24kΩ
40°C	104kΩ	90°C	17.5kΩ
50°C	70kΩ	100°C	13.0kΩ
60°C	48kΩ	110°C	9.8kΩ

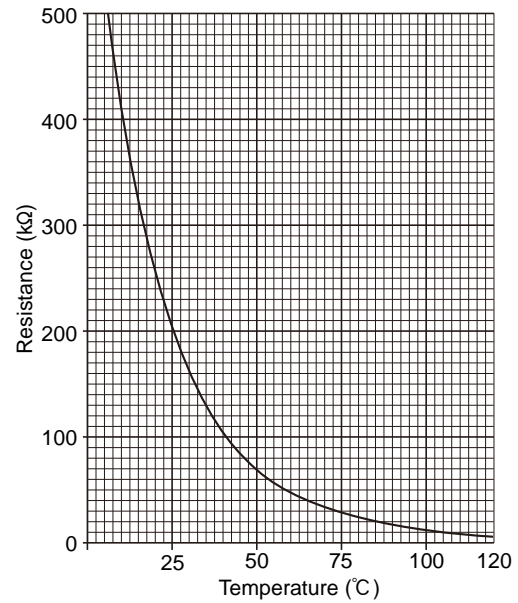

## 10-7. Test point diagram

### FTC3 (Controller board)

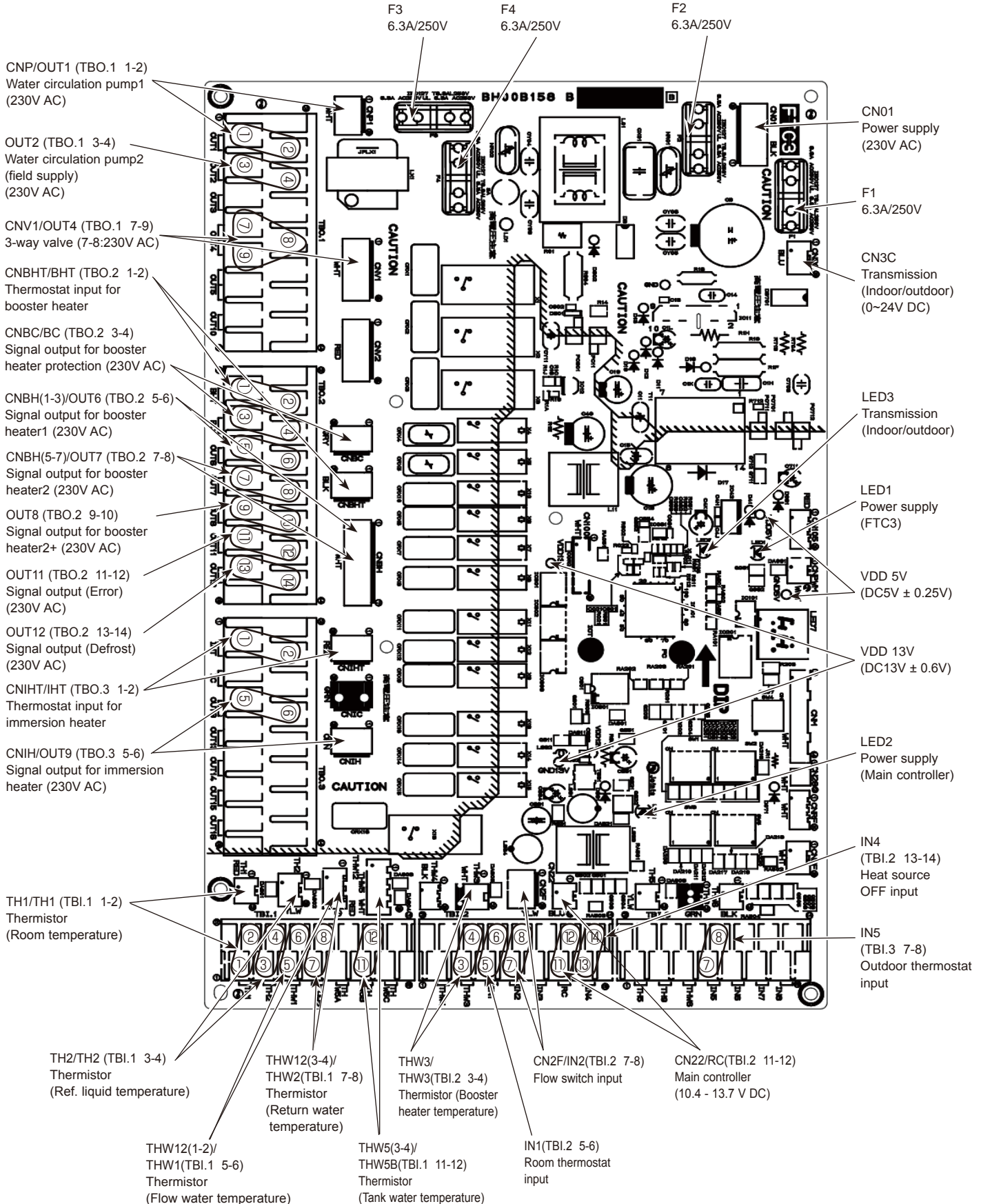

**<Preparation for the repair service>**

- Prepare the proper tools.
- Prepare the proper protectors.
- Provide adequate ventilation.
- After stopping the operation of the cylinder and outdoor unit, turn off the power-supply breaker and remove the power plug.
- Discharge the condenser before the work involving the electric parts.
- Allow parts to cool.
- Do not expose the electric parts to water.
- When replacing or servicing water circuit parts, drain system first.

**EHST20C-VM6HA, EHST20C-YM9HA, EHST20C-VM6A, EHST20C-YM9A, EHST20C-VM6SA,  
EHPT20X-VM2HA, EHPT20X-VM6HA, EHPT20X-YM9HA, EHPT20X-VM6A, EHPT20X-YM9A**

Check individual illustrations and positions of the parts by referring to the parts catalog included in this manual.  
Some lead wires and pipes are bundled with bands. Cut the bands to undo the fastened pipes and lead wires if necessary.  
When bundling the lead wires and pipes again, use new commercially available bands.  
When removing the parts associated with water pipe work, drain the cylinder unit as necessary.  
When draining the cylinder unit, keep water from splashing on the internal parts (mainly electric parts and insulations).

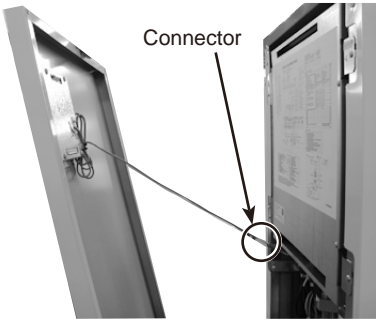
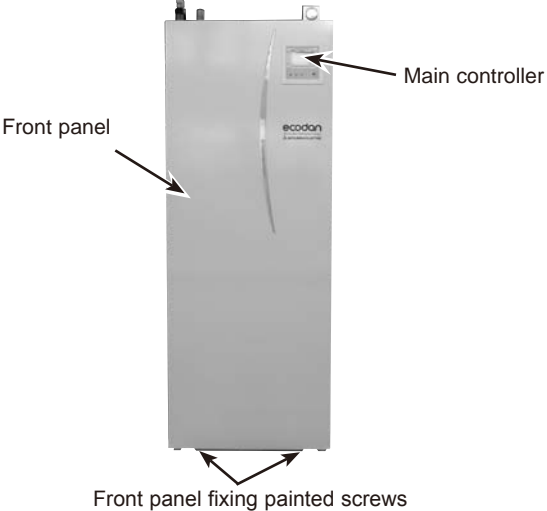
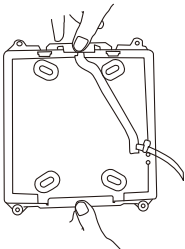
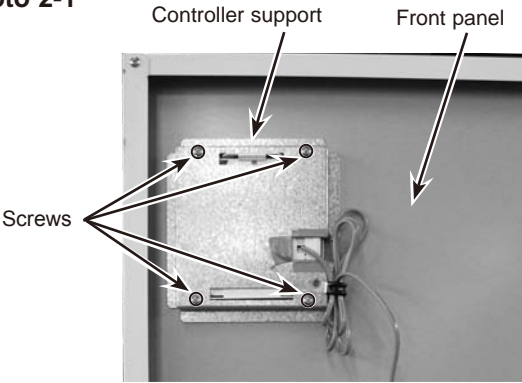
DISASSEMBLY PROCEDURE	PHOTOS & ILLUSTRATION
<p><b>1. How to remove the front panel</b></p> <p>(1) Remove the 2 painted screws at the bottom of the cylinder unit. (Photo 1-1)</p> <p>(2) Slightly lift and pull out the front panel from the cylinder unit. (Photo 1-1)</p> <p>(3) Disconnect the relay connector connecting from the main controller. (Photo 1-2)</p> <p><b>Photo 1-2</b></p> 	<p><b>Photo 1-1</b></p> 
<p><b>2. How to remove the main controller</b></p> <p>(1) Remove the front panel. (Refer to Procedure 1).</p> <p>(2) Turn the front panel over and remove the 4 screws retaining the controller support. (Photo 2-1)</p> <p>(3) Remove the main controller from the case while moving up the claw at the top of the case. (Figure 2-1)</p> <p><b>Figure 2-1</b></p> 	<p><b>Photo 2-1</b></p> 

## DISASSEMBLY PROCEDURE

### 3. How to remove the electrical parts (Steps (1) through (3) are applied to all the following parts.)

#### <Control box cover> (Photo 3-1)

- (1) Remove the front panel. (Refer to Procedure 1).
- (2) Remove the 4 screws holding the control box cover.
- (3) Slightly lift and pull out the control box cover.

#### <Earth leakage breaker> (Photo 3-2)

- (4) Disconnect all the lead wires from the earth leakage breaker.
- (5) Remove the 2 screws on the earth leakage breaker.

**Note:**

To avoid dropping of the breaker, hold the breaker by hand when removing the last screws.

#### <Contactor> (Photo 3-2)

- (4) Disconnect all the lead wires from the contactors.
- (5) Remove the 2 screws on each contactor.

**Note:**

To avoid dropping of the contactors, hold the contactors by hand when removing the last screws.

#### <Terminal block> (Photo 3-2)

- (4) Disconnect all the lead wires from the terminal block. (To disconnect the S1, S2 and S3 lead wires, disengage the locks by pressing on the claws.)
- (5) Remove the screw on the terminal block.

**Note:** To avoid dropping of the terminal block, hold the terminal block by hand when removing the screw .

#### <Controller board> (Photo 3-3)

- (4) Disconnect all the lead wires from the controller board.
- (5) Remove the controller board from the 7 board supports.

## PHOTOS

Photo 3-1

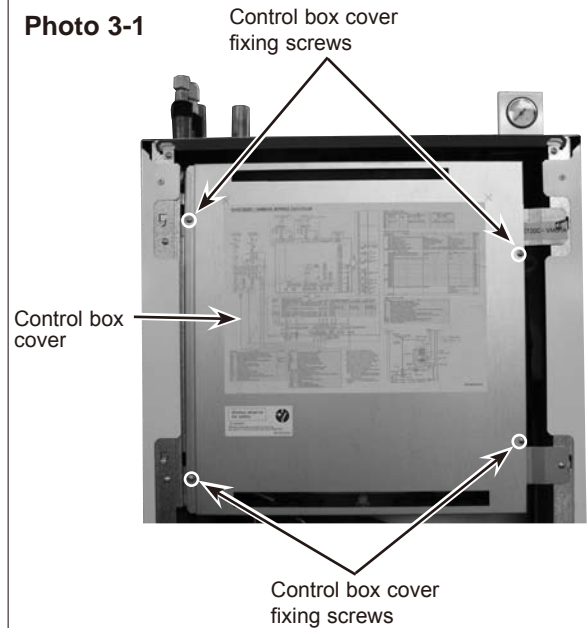
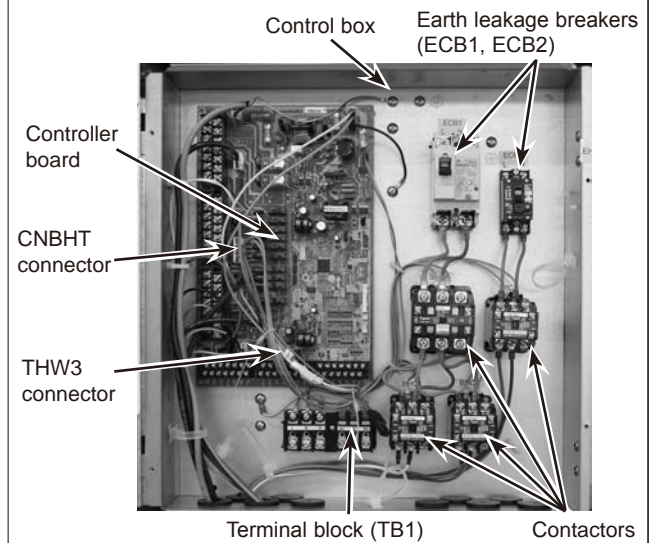
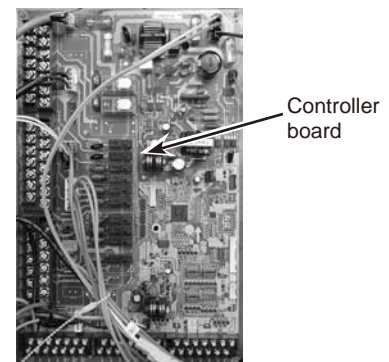

Photo 3-2



※ The photos shown are of the EHST20C-VM6HA model.

Photo 3-3





## DISASSEMBLY PROCEDURE

### 4. How to remove the control box

- (1) Remove the front panel. (Refer to Procedure 1.)
- (2) Remove the control box cover. (Refer to Procedure 3.)
- (3) Disconnect only the lead wires in the control box that connect to the components in the cylinder unit. Photo 4-2 shows the control box after the related lead wires are disconnected.
- (4) Remove the 2 screws on the brackets (R) and disengage the tabs on the 2 control box brackets from the right hand frame. (Photo 4-1)
- (5) Disengage the 2 tabs on the control box bracket (L) from the left hand-side frame. (Photo 4-1)
- (6) Slightly lift and pull out the control box from the cylinder unit while tilting the control box backward.

#### <When swinging the control box to the front>

- (3) Remove the 2 screws on the brackets (R) . (Photo 4-1)
- (4) Remove the 2 cable straps (under the control box). (Photo 4-1)
- (5) Disengage the 2 control box brackets (R) from the right-hand side frame and pull the control box by lifting the right-hand side to swing the control box. (Photo 4-3)

#### Note:

Disconnect the field wiring as necessary.

## PHOTOS

Photo 4-1

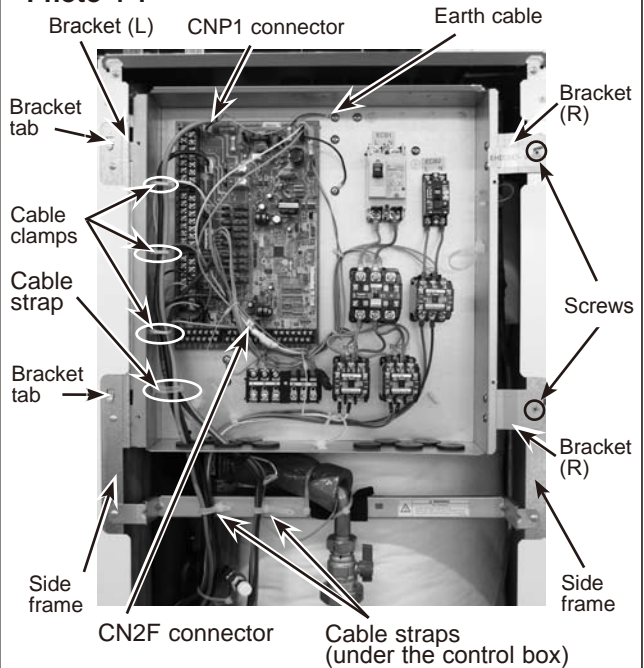

\* The photos shown are of the EHST20C-VM6HA model.

Photo 4-2

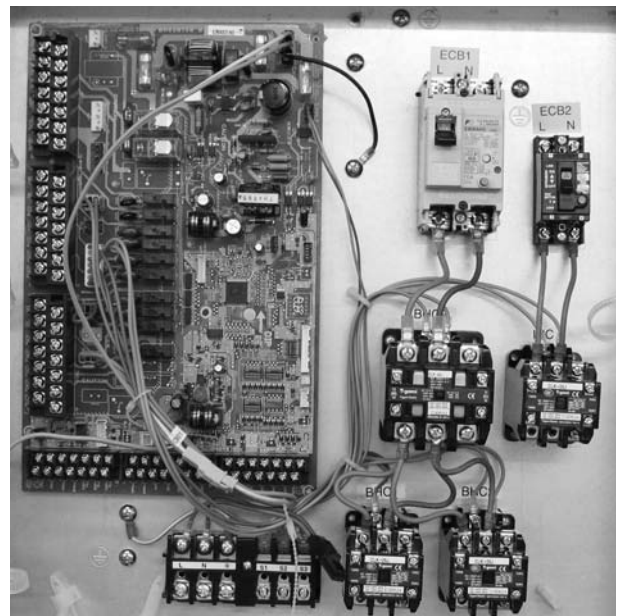
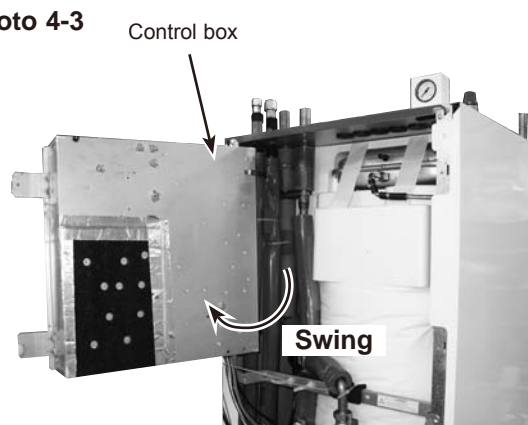

Photo 4-3



## DISASSEMBLY PROCEDURE

### 5. How to remove water pump/ pump valve

#### <Water pump>

- (1) Remove the front panel. (Refer to Procedure 1.)
- (2) Remove the control box cover. (Refer to Procedure 3.)
- (3) Disconnect the CNP1 connector on the controller board and release the lead wire from the 3 cable clamps and the 2 cable straps in the control box, and the 3 bands and the 2 cable straps below the control box, and disconnect the earth cable in the control box. (Photos 4-1 10-1, 10-2)
- (4) Close (OFF) the 2 pump valves and remove the water pump by removing the two 1-1/2" nuts using two spanners: one to hold the pump and the other to turn the individual nuts. (Photo 5-1)
  - ※ When either of the pump valve handles is stiff, remove the individual handles and turn the individual stems 90 degree mainly by using a spanner. (Photo 5-2)
  - ※ When reinstalling the 1-1/2" nuts, use new 1-1/2" gaskets. (Photo 5-4)
  - ※ Set the water pump in the orientation of the arrow printed on the water pump and in the way that the terminal box faces to the front.

#### <Pump valve>

- (5) Remove the pump valves by removing the 1" nuts using two spanners: one to hold each valve and the other to turn each 1" nut.
  - ※ When reinstalling the 1" nuts, use new 1" gaskets. (Photo 5-3)
  - ※ When either of the pump valve handles is stiff, remove the individual handles and turn the individual stems 90 degree mainly by using a spanner. (Photo 5-2)
  - ※ When reinstalling the pump valves, face the individual handles to the right-hand side of the valve as specified.

Note: Skip Steps (2) and (3) above when replacing the pump valves only.  
When replacing both the water pump and the pump valves, skip Step (4) above.

## PHOTOS

Photo 5-1

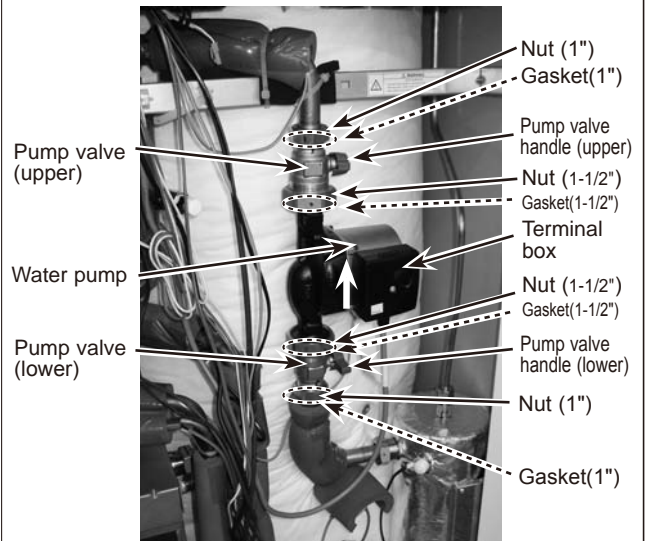

Photo 5-2

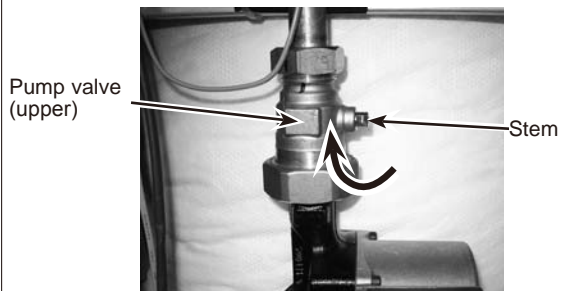

Photo 5-3

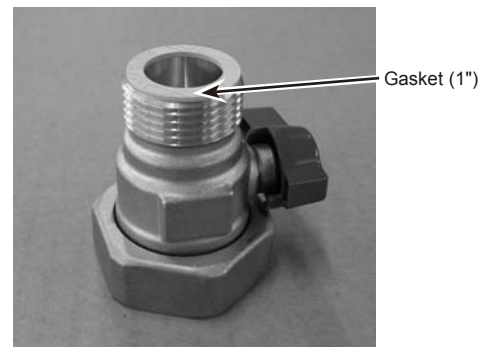
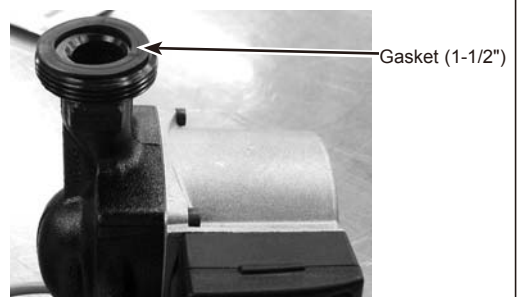

Photo 5-4



## DISASSEMBLY PROCEDURE

### 6. How to remove the 3-WAY VALVE / 3-WAY VALVE MOTOR

- (1) Remove the front panel. (Refer to Procedure 1.)
- (2) Remove the control box. (Refer to Procedure 4.)
- (3) Remove the 3-way valve motor from the 3-way valve while pressing the button on the back of the motor (viewed from the front of the cylinder unit). (Photo 6-2)  
\* Press the button also when reinstalling the 3-way valve motor.

- (4) Remove the 3-way valve by removing the three 1" nuts in the order of the bottom, middle and top using two spanners: one to hold the 3-way valve and the other to turn each nut. (Photo 6-2)  
\* When reinstalling the 1" nuts, use new 1" gaskets.  
A and B shown represent the bottom and the top directions of the 3-way valve, respectively.

#### Note:

Before replacing the motor, be sure to power off the cylinder unit.  
Failure to do so may cause electric shock or cause the 3-way valve to malfunction.

## PHOTOS

Photo 6-1

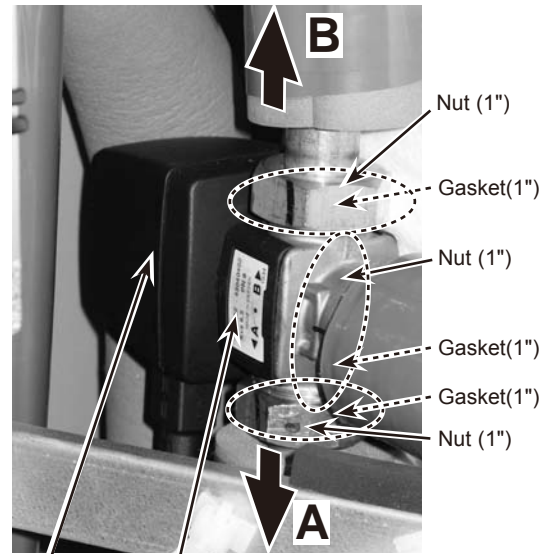

3-way valve motor    3-way valve

Photo 6-2

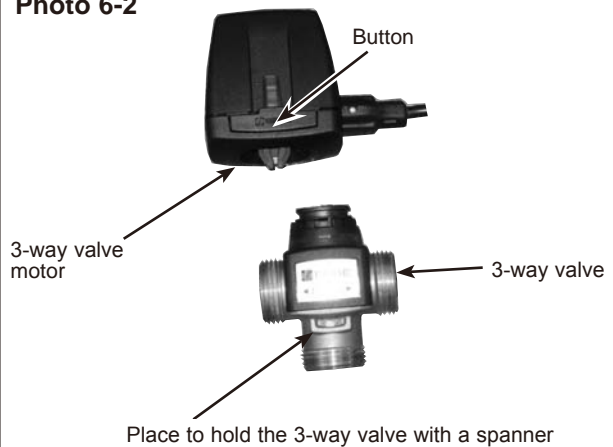



## DISASSEMBLY PROCEDURE

### 7. How to remove the flow switch

- (1) Remove the front panel. (Refer to Procedure 1.)
- (2) Remove the control box cover. (Refer to Procedure 3.)
- (3) Disconnect the CN2F connector on the controller board. (Photo 4-1)
- (4) Release the lead wire from the 5 bands and 2 cable straps. (Photos 10-1, 10-2)
- (5) Close (OFF) the strainer valve handle (under). (Photo 10-2)
  - \* When the valve handle is stiff, remove the handle and turn the vertical stem 90 degree mainly by using a spanner. (Photo 5-2)
- (6) Remove the flow switch by loosening the nut. (Photo 7-1)
  - \* When reinstalling the flow switch, use a new O-ring. (Photo 7-2)

Note: To ensure the correct functioning of the flow switch, check the following when installing it:

- The flow switch paddle is set perpendicularly to the water flow. (Photos 7-2)
- The lead wire of the flow switch points toward the left-hand. (Photo 7-1)
- The lead wire runs parallel to the water pipe. (Figure 7-1)

**Figure 7-1**

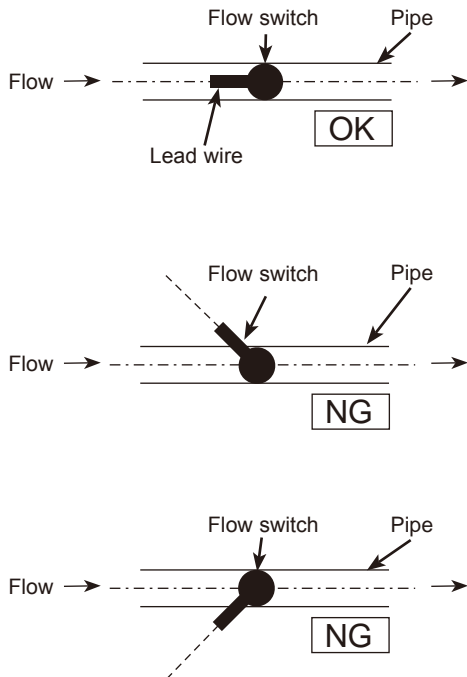

## PHOTOS

**Photo 7-1**

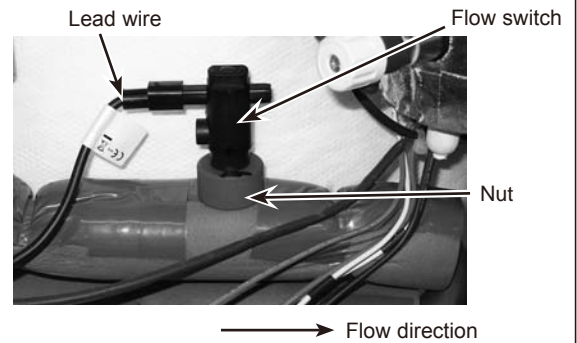

**Photo 7-2**

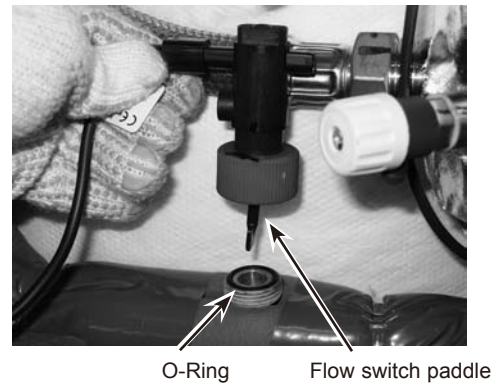

## DISASSEMBLY PROCEDURE

### 8. How to remove the booster heater

- (1) Remove the front panel. (Refer to Procedure 1.)
- (2) Remove the control box cover. (Refer to Procedure 3.)
- (3) Disconnect the CNBHT connector and the THW3 connector on the controller board, and the 4 booster heater lead wires wired to the BHC1 and BHC2 contactors and release the lead wires from the 7 bands and the 2 cable straps. (Photos 8-1, 10-1, 10-2)  
 ※ THW3 will be used later.
- (4) Close (OFF) the pump valve (lower) to stop flow. (Photo 8-2)
- (5) Remove the two 1" nuts. (Photo 8-3)  
 ※ When reinstalling the 1" nuts, use new 1" gaskets.
- (6) Remove the flare nut using two spanners: one to hold the flare joint and the other to turn the flare nut. (Photo 8-3)
- (7) Remove the two screws on the heater stay. Lift the booster heater slightly and remove the booster heater from the heater stay. (Photo 8-4)
- (8) Remove the flare joint from the booster heater. (Photo 8-3)  
 ※ When reinstalling the flare joint, use a new 3/8" gasket.
- (9) Remove the drain cock from the booster heater. (Photo 8-3)  
 ※ Replace the removed drain cock (primary circuit). The reused drain cock could cause water leakage.
- (10) Remove the THW3 thermistor from the booster heater. (Refer to Procedure 20. )

Photo 8-4



## PHOTOS

Photo 8-1

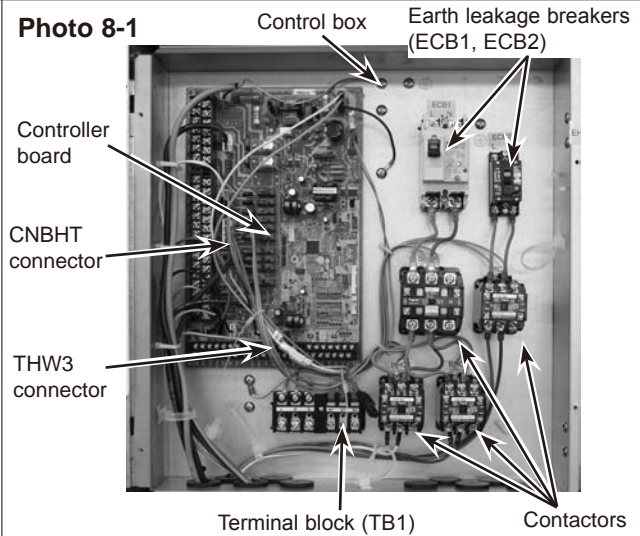

※ The photos shown are of the EHST20C-VM6HA model.

Photo 8-2

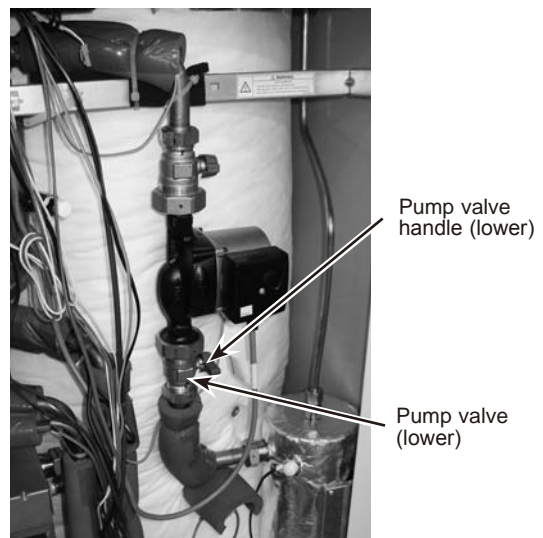
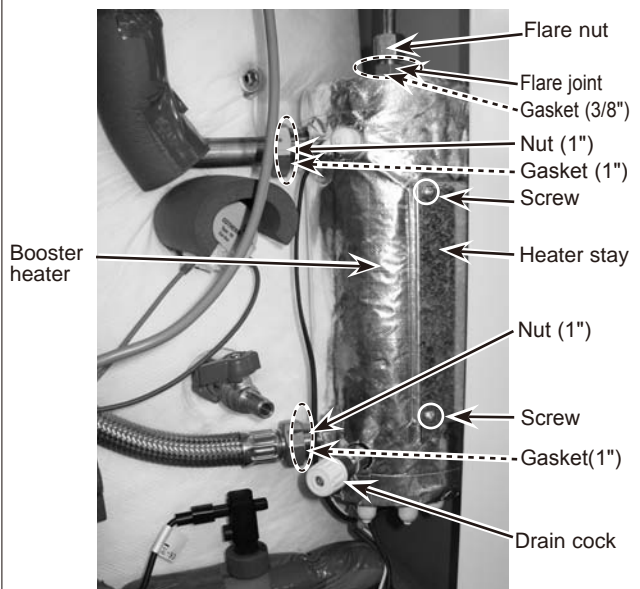

Photo 8-3



## DISASSEMBLY PROCEDURE

### 9. How to remove the thermostat/immersion heater

#### <Thermostat>

- (1) Remove the front panel. (Refer to Procedure 1.)
- (2) Peel off the water-proof tapes on the plastic head of the thermostat in order to reveal the thermostat terminals, and disconnect the lead wires from the terminals. (Photo 9-1)
  - \* Use new commercially available water-proof tapes to cover the terminals again.
- (3) Pull out the thermostat.

#### <Immersion heater>

- (4) Remove the tab cover and remove the back nut (1-3/4") using the tool included with the immersion heater. (Photo 9-2)
- (5) Pull out the immersion heater.
  - \* When reinstalling the immersion heater, use a new 1-3/4" gasket.

Note: When replacing the immersion heater only, skip Step (2) and cut the band shown. (Photo 9-3)  
After reinstalling the back nut with the tab cover onto the tank, insert the immersion heater straight into the tank through the back nut in order to provide adequate sealing. Failure to do so may cause water leakage. Always check for water leakage after installation.

## PHOTOS

Photo 9-1

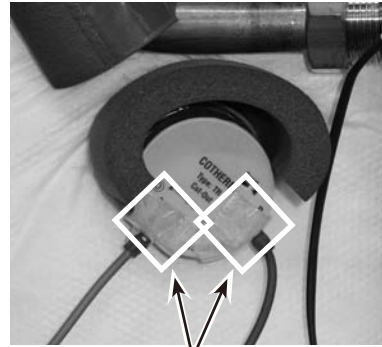

Water-proof tapes

Photo 9-2

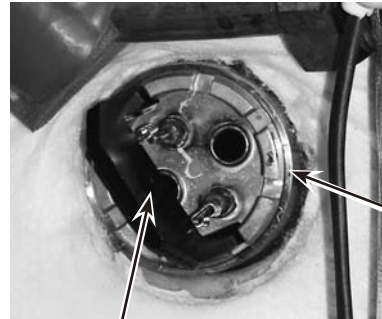

Tool (\*2)

Back nut  
(1-3/4")

(\*2) When the model is the cylinder unit including immersion heater, the tool is included with the unit. The tool is also included with the immersion heater of optional parts.

Photo 9-3



Band

Lead wires

Thermostat/  
Immersion heater

Back nut

## DISASSEMBLY PROCEDURE

### 10. How to remove the plate heat exchanger

- (1) Remove the front panel. (Refer to Procedure 1.)
- (2) Pump down the refrigerant circuit and close the stop valve at the outdoor unit side. (Refer to 12. SUPPLEMENTARY INFORMATION.)
- (3) Remove the control box. (Refer to Procedure 4.)
- (4) Cut the bands and remove the pump frame. (Photo 10-1)
- (5) Cut the bands bundling the pipes. (Photos 10-2, 10-3)
- (6) Remove the 2 flare nuts on the refrigerant piping on top of the cylinder unit. (Photo 10-3)
- (7) Close (OFF) the strainer valve handle (under).
  - \* When the valve handle is stiff, remove the handle and turn the vertical stem 90 degree mainly by using a spanner. (Photo 5-2)
- (8) Remove the 1" nut at the booster heater side of the flexible hose. (Photo 10-2)
  - \* When reinstalling the 1" nut, use a new 1" gasket.
- (9) Remove the 1" nut under the strainer valve. (Photo 10-2)
  - \* When reinstalling the 1" nut, use a new 1" gasket.
- (10) Remove the 4 screws fixing the plate heat exchanger. (Photo 10-2)

## PHOTOS

Photo 10-1

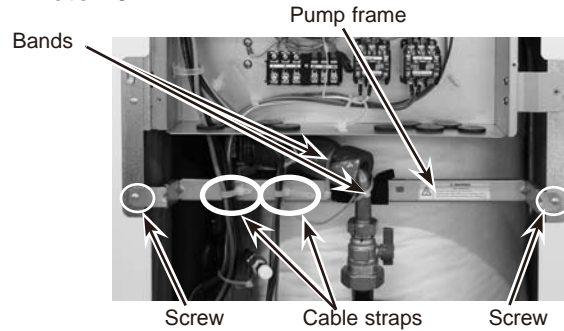

Photo 10-2

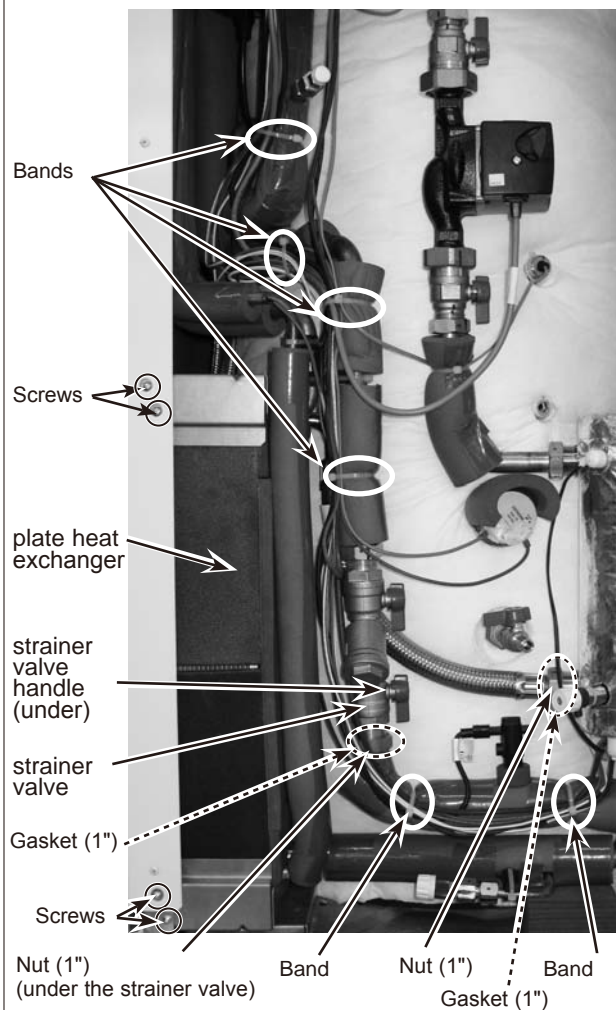
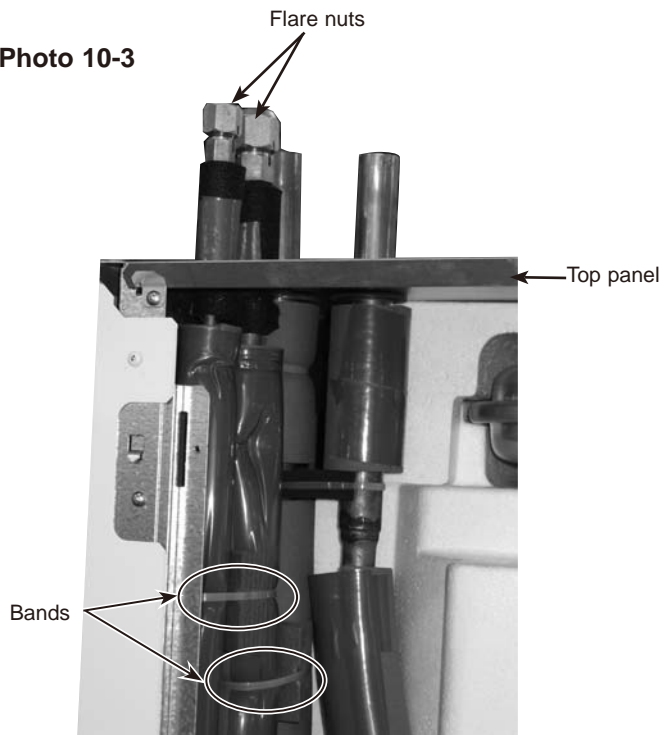

Photo 10-3





## DISASSEMBLY PROCEDURE

### 10. How to remove the plate heat exchanger

- (10) Displace the plate heat exchanger together with the refrigerant pipes, the water pipe and the flexible hose to the front of the cylinder unit while feeding the top ends of the 2 refrigerant pipes through the openings in the top panel and remove the heat exchanger unit from the cylinder unit. (Photos 10-3, 10-4, 10-5)
- (11) Loosen the 1" nut on the water pipe and remove the water pipe from the plate heat exchanger.
- ※ When reinstalling the nut, use a new 1" gasket.
  - ※ When reinstalling the plate heat exchanger, reuse the water pipe.

Photo 10-5

Nut on the flexible hose

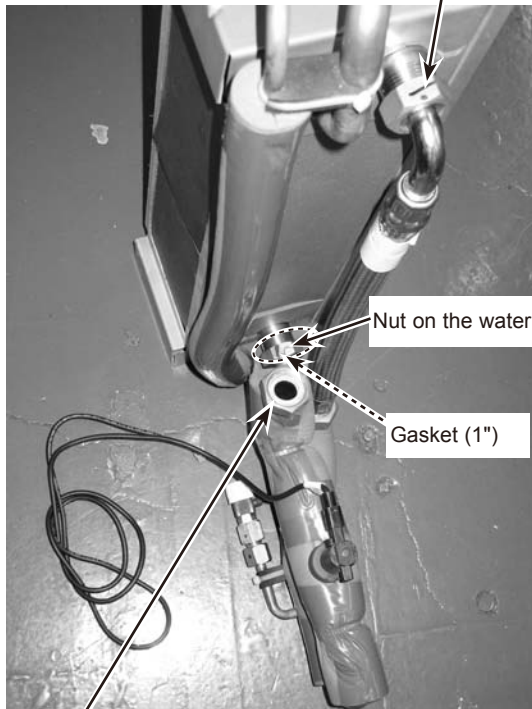

Nut on the water pipe (1")

Gasket (1")

Nut under the strainer valve

## PHOTOS

Photo 10-4

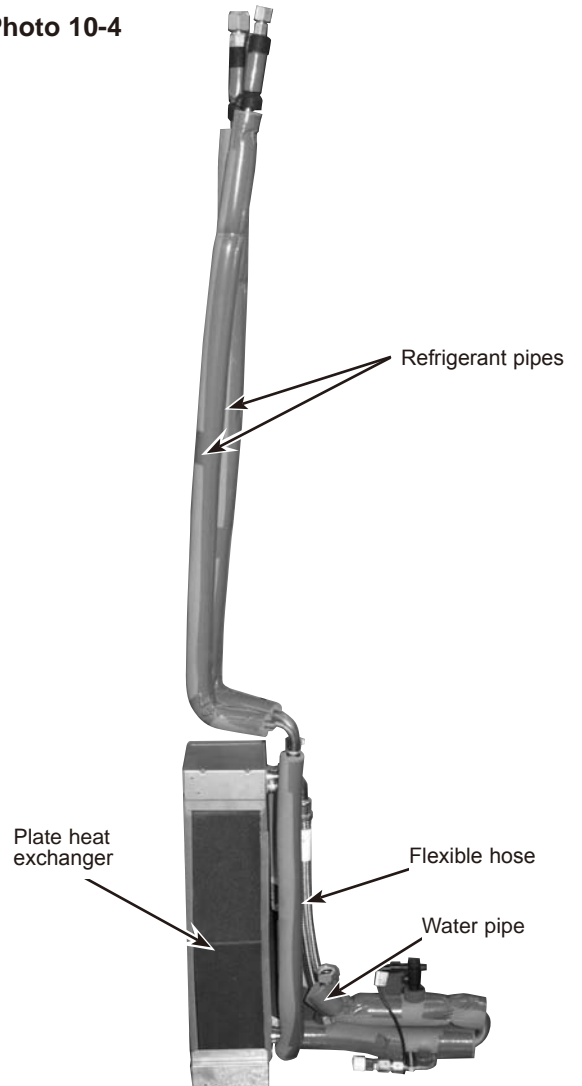

Refrigerant pipes

Plate heat exchanger

Flexible hose

Water pipe

### 11. How to remove the strainer

- (1) Remove the front panel. (Refer to Procedure 1.)
- (2) Close (OFF) the 2 strainer valves.
- ※ When either of the strainer valve handles is stiff, remove the individual handles and turn the individual stems 90 degree mainly by using an adjustable spanner. (Photo 5-2)
- (3) Remove the two 1" nuts using two spanners: one to hold the strainer and the other to turn the individual 1" nuts.
- ※ When reinstalling the 1" nuts, use new 1" gaskets.

<Removal of the strainer cover (debris recovery)>

- (3) Remove the cover using two spanners: one to hold the strainer and the other to turn the cover.
- ※ Be sure to reattach the mesh after washing it.
  - ※ When placing the strainer back into place, use a new O-ring. (Photo 11-2)

Photo 11-2

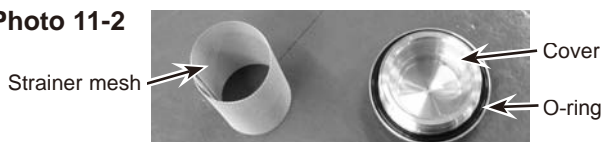

Strainer mesh

Cover

O-ring

Photo 11-1

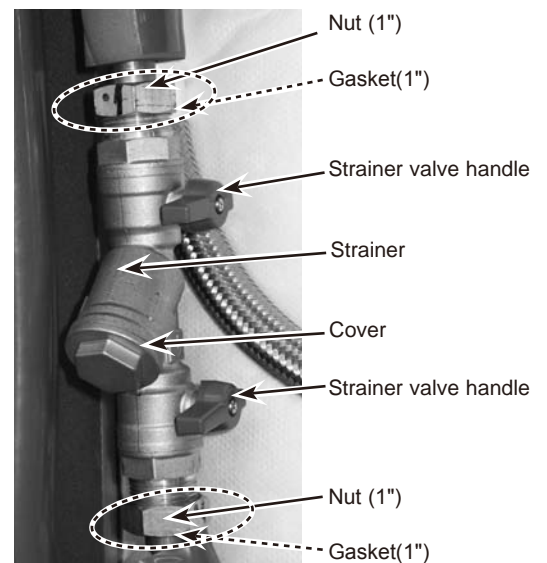

Nut (1")

Gasket(1")

Strainer valve handle

Strainer

Cover

Strainer valve handle

Nut (1")

Gasket(1")

## DISASSEMBLY PROCEDURE

### 12. How to remove the pressure relief valve / manometer / air vent (automatic)

- (1) Remove the front panel. (Refer to Procedure 1.)
- (2) Swing the control box to the front. (Refer to Procedure 4.)

#### <Manometer>

- (3) Remove the 2 screws on the manometer stay on top of the cylinder unit. (Photo 12-1)
- (4) Remove the 1/4" nut from the pressure relief valve and remove the capillary tube from the pressure relief valve.  
\*When reinstalling the 1/4" nut, use a new 1/4" gasket. (Photo 12-2)
- (5) Remove the manometer assembly from the cylinder unit.
- (6) Remove the manometer from the manometer stay while pressing on the claws. (Photo 12-3)  
\* Beware not to put strain on the root of the capillary tube as the capillary tube is easy to break at the root. (Photo 12-3)

#### <Pressure relief valve>

- (3) Remove the field piping from the pressure relief valve.
- (4) Remove the 1/4" nut and remove the capillary tube from the pressure relief valve. (Photo 12-2)  
\*When reinstalling the 1/4" nut, use a new 1/4" gasket. (Photo 12-2)
- (5) Remove the pressure relief valve with a flare joint using two spanners: the one to hold the flare joint and the other to turn the flare nut under the top panel. (Photo 12-4)
- (6) Remove the pressure relief valve using two spanners: one to hold the adaptor and the other to turn the pressure relief valve. (Photo 12-5)
- (7) Eliminate locktite on the thread surfaces using remover. (Photo 12-5)  
\*Before reinstallation, apply locktite over the thread surface on the pressure relief valve.  
\*For more details about the locktite and the remover, refer to Page 71.

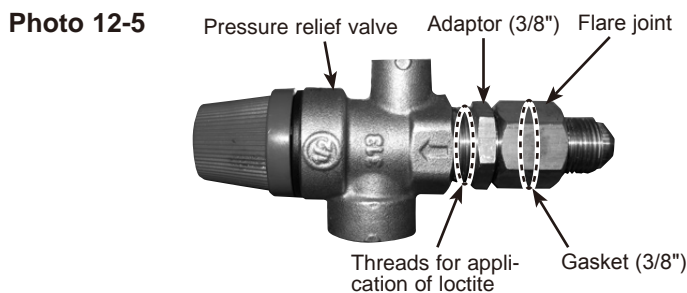

#### <Air vent (automatic)>

- (3) Remove the air vent (automatic) using two spanners: one to hold the flare joint and the other to turn the flare nut under the top panel. (Photos 12-2 and 12-4)
- (4) Remove the air vent with the flare joint. (Photo 12-4 and 12-6)
- (5) Remove the flare joint from the air vent. (Photo 12-6)

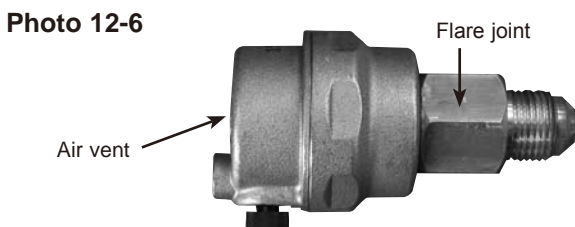

## PHOTOS

**Photo 12-1**

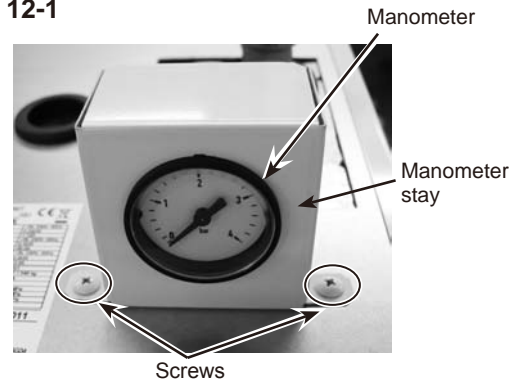

**Photo 12-2**

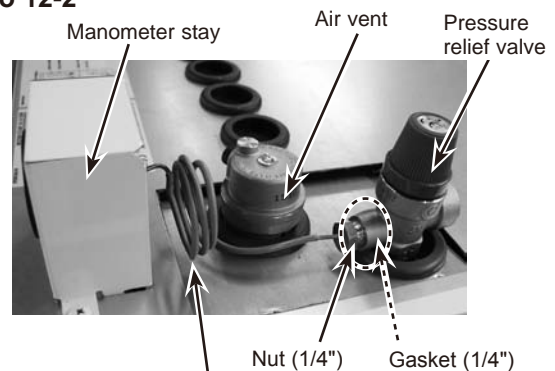

**Photo 12-3**

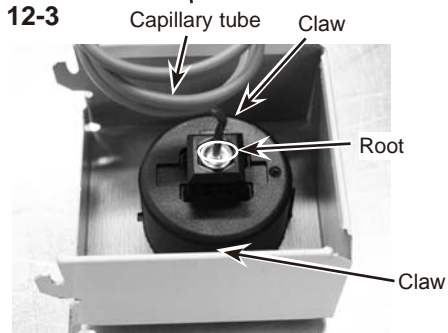

**Photo 12-4 (Under the top panel)**

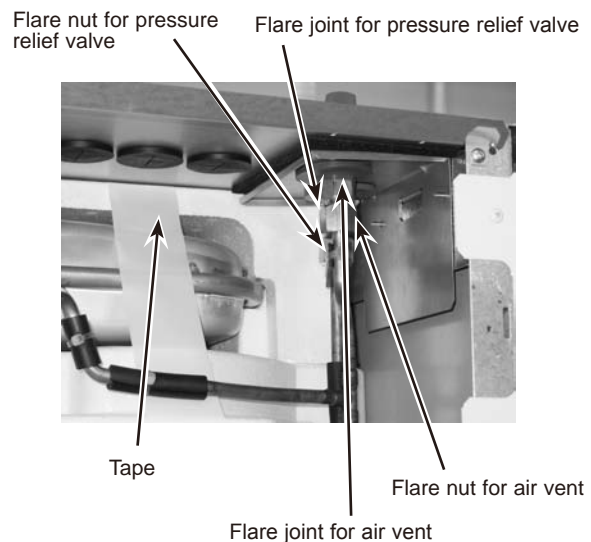

## DISASSEMBLY PROCEDURE

### 13. How to remove the expansion vessel

- (1) Remove the front panel. (Refer to Procedure 1.)
  - (2) Swing the control box to the front. (Refer to Procedure 4.)
  - (3) Remove the flare nut using two spanners: one to hold the flare joint and the other to turn the flare nut.
  - (4) Displace the pipe slightly downward and pull out the expansion vessel.
  - (5) Remove the flare joint from the expansion vessel.
    - \* When reinstalling the flare joint, use a new 3/8" gasket.
- Note: To avoid dropping of the expansion vessel, hold it by hand when removing it.

## PHOTOS

Photo 13-1

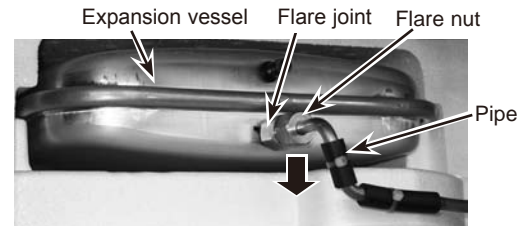
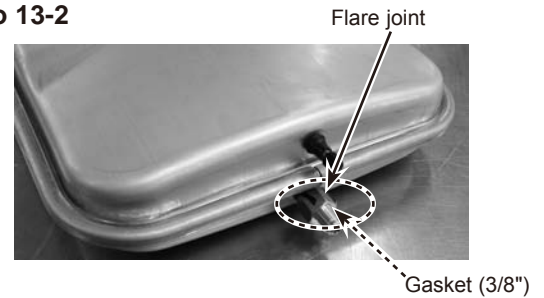

Photo 13-2



### 14. How to remove the temperature and pressure (T&P) relief valve (EHPT20X-VM2HA only)

- (1) Remove the front panel. (Refer to Procedure 1.)
  - (2) Swing the control box to the front. (Refer to Procedure 4.)
  - (3) Remove the field piping from the temperature and pressure relief valve.
  - (4) Turn the back nut (1-3/4") using a specified tool and remove the temperature and pressure relief valve. (Photo 14-2)
  - (5) Eliminate locktite on the thread surfaces using remover. (Photo 14-3)
- \* Before reinstallation, apply locktite over the thread surface on the temperature and pressure relief valve and install the temperature and pressure relief valve with the T&P joint and the back nut.
  - \* When reinstalling the T&P relief valve, point the nut to the bottom as specified. (Photo 14-1)
  - \* For more details about the locktite and the remover, refer to Page 71.
  - \* When reinstalling the T&P, use a new 1-3/4" gasket.

Photo 14-1

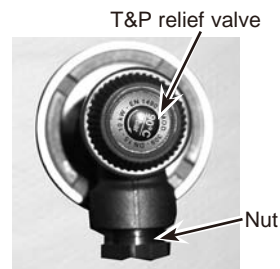
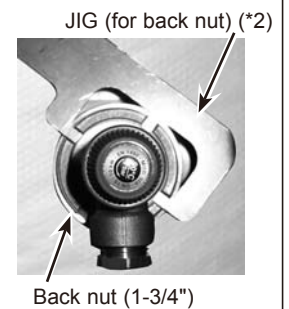
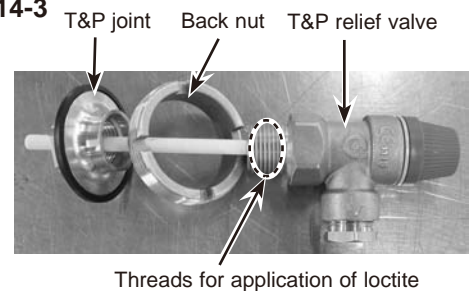

Photo 14-2



(\*2) The JIG is set as a service part.

Photo 14-3



### 15. How to remove the air vent (manual)

- (1) Remove the front panel. (Refer to Procedure 1.)
- (2) Remove the air vent (manual) with a flare joint using two spanners: one to hold the flare joint and the other to turn the flare nut.
- (3) Remove the flare joint from the air vent.

Photo 15-1

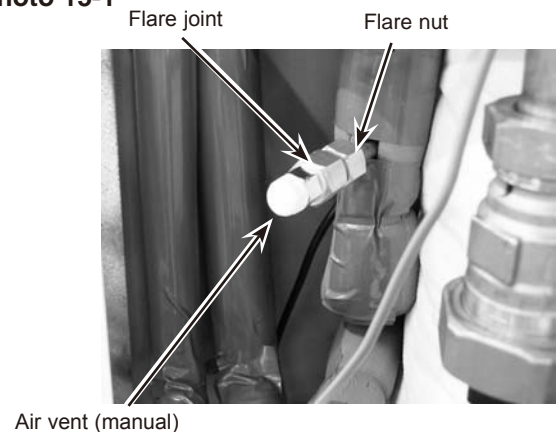

## DISASSEMBLY PROCEDURE

### 16. How to remove the drain cock (primary circuit)

(1) Remove the front panel. (Refer to Procedure 1.)

#### Booster heater side

(2) Remove the drain cock from the booster heater by turning the drain cock.

#### Pipe side

(2) Remove the drain cock from the pipe using two spanners: one to hold the flare joint and the other to turn the flare joint nut.

(3) Remove the flare joint from the drain cock.

## PHOTOS

Photo 16-1

Drain cock  
(booster heater side)

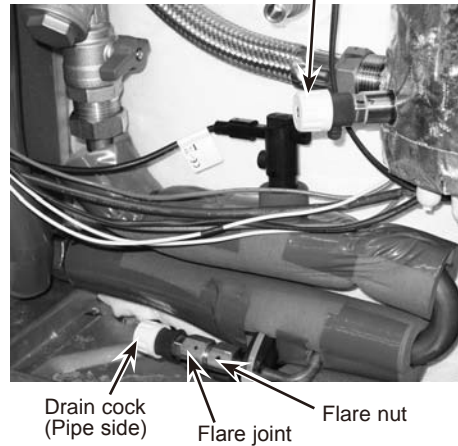

### 17. How to remove the drain cock (sanitary circuit)

(1) Remove the front panel. (Refer to Procedure 1.)

(2) Remove the drain cock by removing the nut.

\* When reinstalling the nut, use a new 3/4" gasket.

Photo 17-1

Drain cock (sanitary circuit)

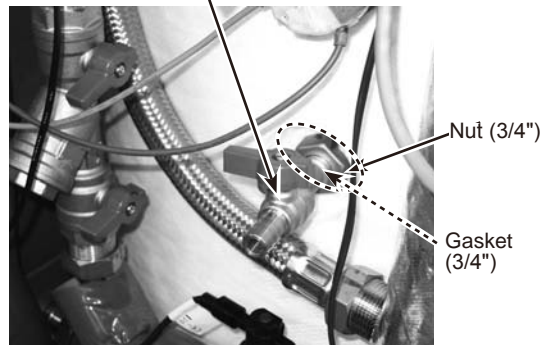

### 18. How to remove the flexible hose

#### Between the plate heat exchanger and the booster heater

(1) Remove the plate heat exchanger from the cylinder unit. (Refer to Procedure 10.)

(2) Remove the flexible hose from the plate heat exchanger by removing the 1" nut. (Photo 18-2)

\* When reinstalling the 1" nuts, use new 1" gaskets.

#### DHW tank side

(1) Remove the left-hand side panel. (Refer to Procedure 21.)

(2) Disconnect the flexible hose by turning the nuts on the hose ends.

\* When reinstalling the nuts, use new 3/4" gaskets.

Photo 18-1

Flexible hose

Booster heater

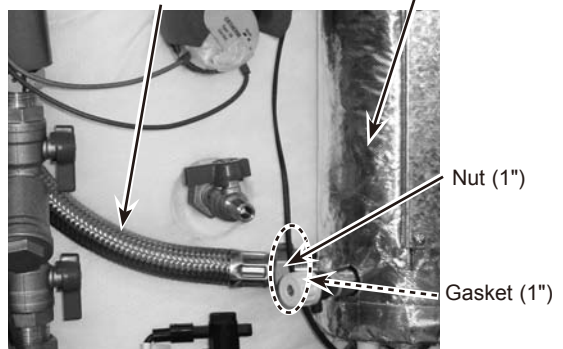

Photo 18-2

Plate heat exchanger

Nut (1")

Gasket (1")

Flexible hose

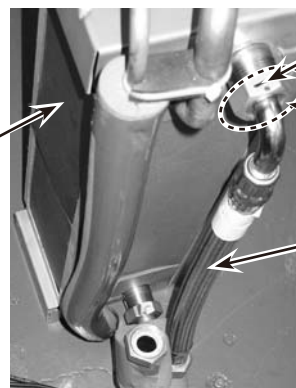
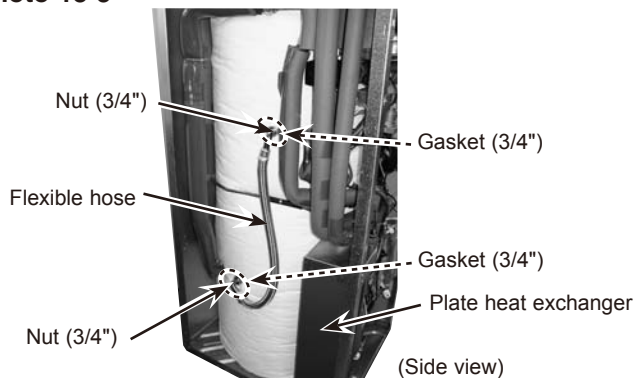

Photo 18-3





## DISASSEMBLY PROCEDURE

### 19. Remove the liquid refrigerant temp. thermistor (TH2) / flow water temp. & return water temp. thermistor (THW1, THW2) / tank water temp. thermistor (THW5B)

- (1) Remove the front panel. (Refer to Procedure 1.)
- (2) Remove the control box cover. (Refer to Procedure 3.)
- (3) Disconnect the following thermistor connectors on the controller board and release the lead wires from cable clamps and bands.
  - TH2 (TH2) (1 cable clamp, 2 cable straps and 3 bands)
  - THW1 (THW12) (1 cable clamp, 2 cable straps and 1 band)
  - THW2 (THW12) (1 cable clamp, 2 cable straps and 2 bands)
  - THW5B (THW5) (2 cable clamps, 2 cable straps and 4 bands)
- (4) Remove the thermistors from the thermistor holders.

**Photo 19-2**

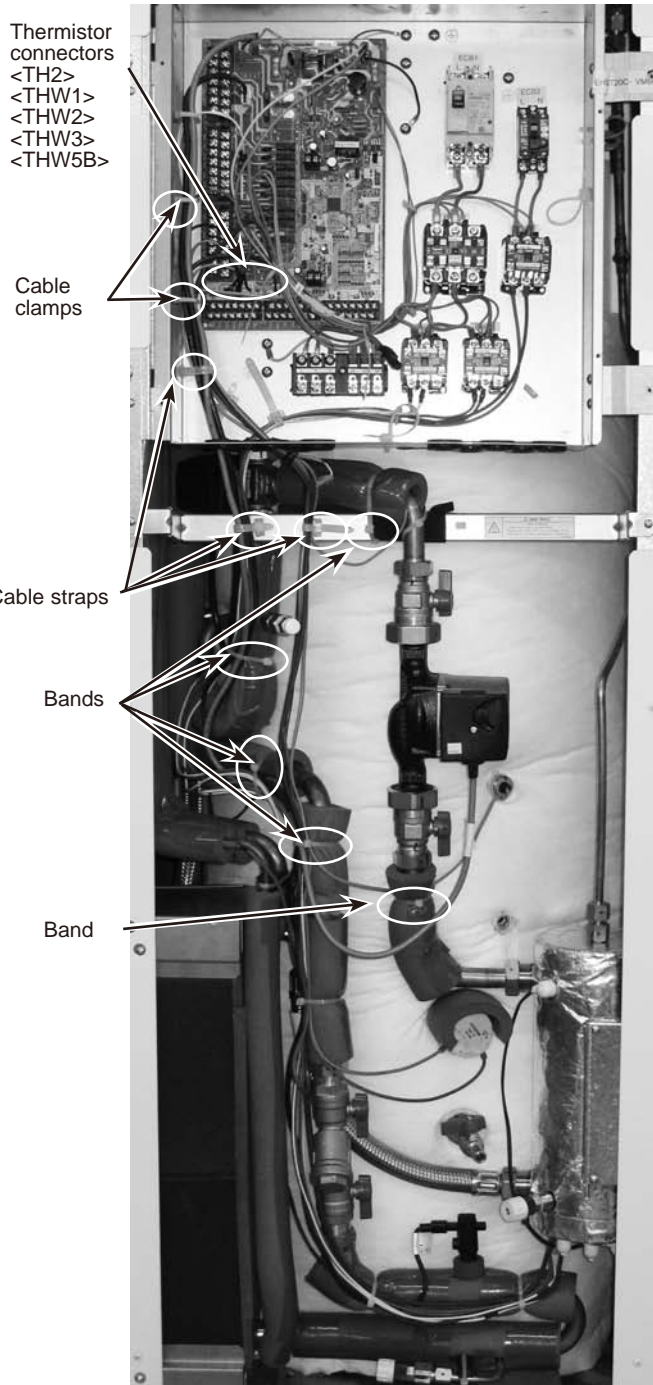

## PHOTOS

**Photo 19-1**

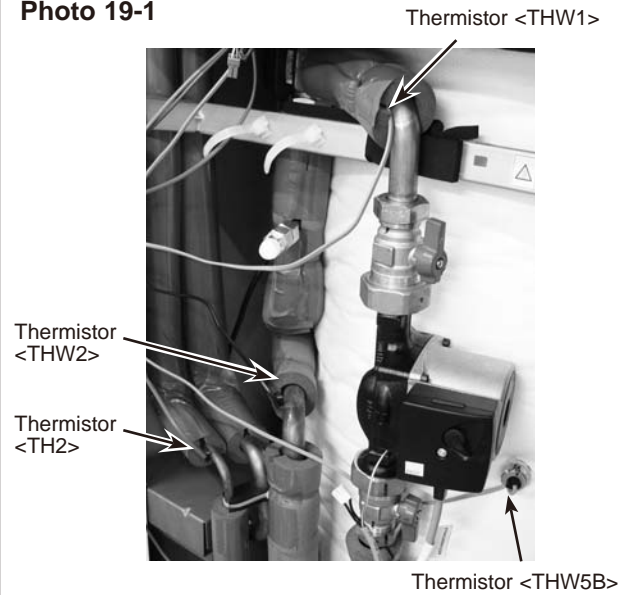

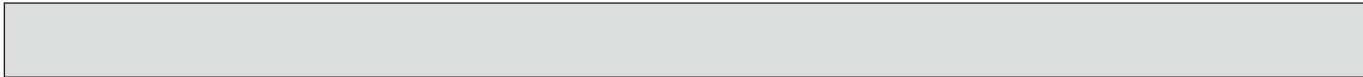

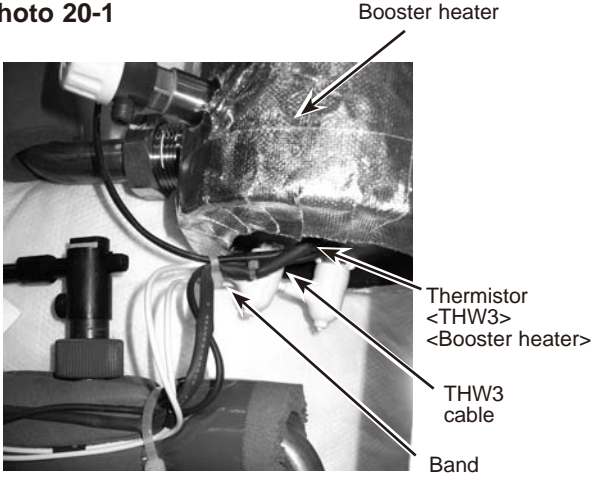
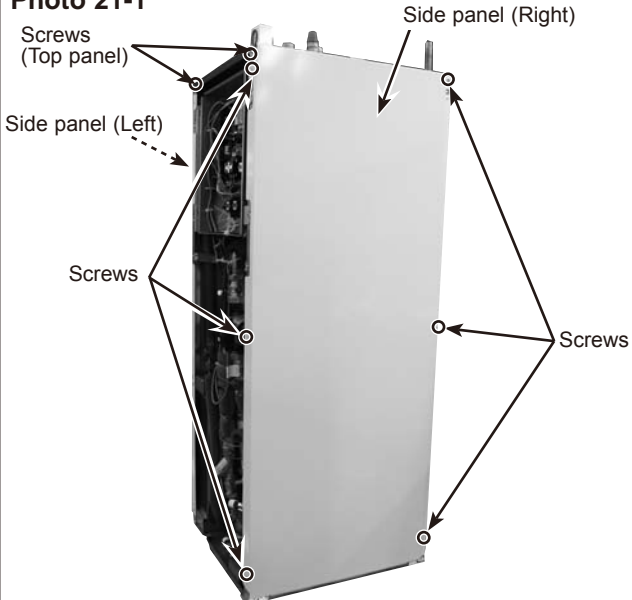
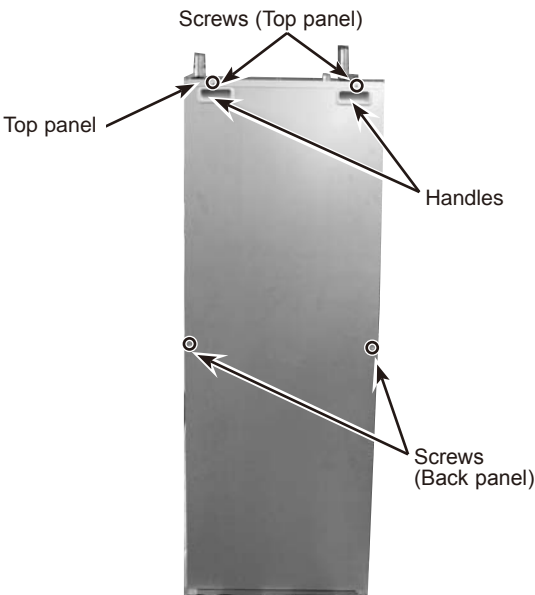
DISASSEMBLY PROCEDURE	PHOTOS
<p><b>20. How to remove the booster heater temp. thermistor (THW3)</b></p> <ol style="list-style-type: none"><li>(1) Remove the front panel. (Refer to Procedure 1.)</li><li>(2) Remove the control box cover. (Refer to Procedure 3.)</li><li>(3) Remove the THW3 connector on the controller board. (Photo 19-2)</li><li>(4) Cut the band bundling the THW3 cable.</li><li>(5) Run the thermistor cable out the bottom of the booster heater and remove the THW3 thermistor.</li></ol> <p>Note:</p>	<p><b>Photo 20-1</b></p>  <p>Booster heater</p> <p>Thermistor &lt;THW3&gt; &lt;Booster heater&gt;</p> <p>THW3 cable</p> <p>Band</p>
<p><b>21. How to remove the side panels</b></p> <ol style="list-style-type: none"><li>(1) Remove the front panel. (Refer to Procedure 1.)</li><li>(2) Remove the side panel by removing 12 screw fixing the side panels (6 screws each on the right and left panels).</li></ol> <p>Note:</p> <p>Photo 21-1 shows the right side panel only. The left side panel will be removed by the same procedure.</p>	<p><b>Photo 21-1</b></p>  <p>Side panel (Right)</p> <p>Side panel (Left)</p> <p>Screws (Top panel)</p> <p>Screws</p>
<p><b>22. How to remove the back panel</b></p> <ol style="list-style-type: none"><li>(1) Remove the front panel. (Refer to Procedure 1.)</li><li>(2) Remove the side panels. (Refer to Procedure 21.)</li><li>(3) Remove the 4 screws (2 each at the front and back) on the top panel .</li><li>(4) Remove the 2 screws on the back panel, and pull out the back panel while lifting the top panel.</li></ol> <p>Note:</p> <p>The handles are removed by pushing them up.</p>	<p><b>Photo 22-1</b></p>  <p>Screws (Top panel)</p> <p>Top panel</p> <p>Handles</p> <p>Screws (Back panel)</p>

## Notes on replacing the parts

Replacement of the parts listed below requires the following procedure.

After the parts are removed, eliminate loctite on threads by applying loctite remover, apply new loctite, and then install and tighten the parts to the specified tightening torques below. For details about recommended loctite and loctite remover, refer to Table 11-1, and for details about the replacement parts and their tightening torques, refer to Table 11-2.

**Table 11-1**

Recommended	Manufacturer	No.	Note
Loctite	Henkel	Loctite 577	Apply loctite all over from the end of external thread to the second ridge. After installing the parts, fix the parts for at least 30 minutes
Loctite remover	Henkel	Loctite 7200 Gasket Remover	Spray loctite remover over sealant on the threads, let the sealant sit until soft, and then eliminate it with a wire brush.

Note: When using the products above, refer to the appropriate manuals that come with the individual products.

**Table 11-2**

PARTS CATALOG				Recommended tightening torque [Nm] *2
Page	No.	Part No.	Part name *1	
3, 5, 7, 9	1	S70 C18 404	PRESSURE RELIEF VALVE 3bar	15 ± 1
11	15	S70 C19 404	TEMPERATURE AND PRESSURE RELIEF VALVE	15 ± 1
11	8	S70 C11 525	STAT POCKET ASSEMBLY	12 ± 1

\*1. For more details about the listed parts refer to the parts catalogue included in this manual.

\*2. Undertightening and overtightening the parts affect water seal life. Tighten the parts to the appropriate tightening torques.

When installing the parts that are not listed above, observe the tightening torques in accordance with Table 11-3.

Always use a new O-ring or gasket.

**Table 11-3**

	Size [inch]	Recommended tightening torque [Nm]
Gasket	1/4"	8 ± 1
	3/8"	15 ± 1
	3/4"	36 ± 2
	1"	42 ± 2
	1 1/2"	42 ± 2
	1 3/4"	10 ± 1
O-ring	Strainer cover	45 ± 4.5
	Flow switch	8 ± 1
	Air vent (Automatic)	15 ± 1
Attached packing	Drain cock (primary circuit)	15 ± 1
	Air vent (manual)	15 ± 1
Flare joint (for water circuit parts)		35 ± 2

After the procedure is complete, ensure that no water leaks.

**Refrigerant recovery (pump down) for split systems only**

For split system the following procedures should be followed to recover system refrigerant:

**Note) Pump down operation can not be activated by switching the pump down switch (SWP) or test run switch on the outdoor unit PCB.**

Ensure both the outdoor unit and the indoor unit are in emergency mode before carrying out the following.

For pump down operation in split systems both the indoor and the outdoor unit must be in emergency mode.

Please see the following instructions on how to activate emergency mode.

Before carrying out the pump down, ensure the water pump is functioning correctly and L9 error code is not displayed on the main controller.

If there is insufficient water circulation, the circuit may freeze causing damage to the plate HEX.

If there is a fault with the pump or L9 error code is displayed on the main controller, do not attempt pump down operation.

In this case a refrigerant recovery machine must be used.

1. Isolate outdoor unit from power supply by switching OFF relevant circuit breaker.  
If the indoor unit is powered independently to the outdoor unit, ensure that both units are isolated from the power supply.
2. Fully close the stop valve on the refrigerant (liquid) pipe and attach the pressure gauge to the port on the low pressure side of the compressor refrigerant pipe work.  
Change the position of the connector CN31 to ON and change DipSW4-2 to OFF on the outdoor unit PCB.  
Change the DipSW4-5 on the indoor unit to ON.
3. Switch ON power to the outdoor unit.  
If the indoor unit is powered independently, switch on power to the indoor unit first, then switch on power to the outdoor unit.  
Outdoor and indoor unit will start operating in emergency mode.  
**Note) If the outdoor unit is operated whilst the indoor unit is switched off, this could cause serious damage to the plate HEX.**  
**Always ensure the indoor unit power supply is ON and water pump is operating before switching ON power to the outdoor unit.**  
**After reconnecting power supply, ensure the water pump is operating correctly.**  
**If the water pump is not operating normally, then this could cause the water circuit to freeze damaging the plate HEX.**
4. When the pressure gauge reads close to 0MPa (G), close the valve on the refrigerant (gas) pipe and then switch power to outdoor unit OFF.  
If the indoor unit is powered independently ensure power supply for unit is OFF.  
**Note) It is important that after closing the valve on the refrigerant (gas) pipe the power supply is quickly switched OFF.**  
**If the system is running at a pressure of 0MPa (G) or lower, it may cause damage to the compressor.**
5. After completing the pump down operation, return the position of the connector CN31 on the outdoor unit PCB to OFF.  
Change the Dip SW4-5 on the indoor unit to OFF.

### Engineers form

The main controller settings changed from the default settings are reset by replacing the controller board. To facilitate reselecting settings on the main controller, it is recommended to write down the changes in the sheet below before replacement.

#### Commissioning/Field settings record sheet

			Parameters	Default setting	Field setting	Notes	
<b>Main</b>	Option	Forced DHW operation	On/Off	Off			
		DHW	On/Off/Timer	On			
		Heating	On/Off/Timer	On			
		Holiday mode	Active/Non active/Set time	Non active			
<b>Setting</b>	DHW	Operation mode	Normal/Eco	Normal			
		DHW max. temp	40°C – 60°C	50°C			
		DHW temperature drop	5°C – 30°C	10°C			
		DHW max. operation time	30 – 120 mins	60 mins			
		DHW mode restriction	30 – 120 mins	30 mins			
		Active	Yes/No	Yes			
	Legionella prevention	Hot water temp	60°C – 70°C	65°C			
		Frequency	1 – 30 days	15 days			
		Start time	00.00 – 23.00	03.00			
		Max. operation time	1 – 5 hours	3 hours			
		Duration of maximum temperature	1 – 120 mins	30 min			
		Active	Yes/No	Yes			
	Heating	Heating	Operation mode	Flow temp/Compensation curve/Room temp	Room temp		
			Heating room temp	10°C – 30°C	20°C		
			Heating flow temp	25°C – 60°C	45°C		
	Compensation curve	Lo set point	Outdoor ambient temp	-15°C – 35°C	35°C		
			Flow temp	25°C – 60°C	25°C		
		Hi set point	Outdoor ambient temp	-15°C – 35°C	-15°C		
			Flow Temp	25°C – 60°C	50°C		
		Adjust	Outdoor Ambient Temp	-14°C – 34°C	—		
			Flow temp	25°C – 60°C	—		
	Schedule timer	Active	Yes/No	No			
	Holiday	DHW	Active/Non active	Non active			
		Heating	Active/Non active	Active			
		Heating room temp	10°C – 30°C	15°C			
		Heating flow temp	25°C – 60°C	35°C			
	Initial settings	Language	ENG/PT/NOR/FIN/NL/DA/IT/SP/SW/GER/FR	ENG			
		°C/°F	°C/°F	°C			
		Temp display	On/Off	Off			
		Time display	hh:mm/hh:mm AM/AM hh:mm	—			
		Room sensor setting	TH1/Main RC/Room RC1-8/(Time/Zone)	TH1			
		Manual operation	Supplementary pump or 3 way valve On/Off	Off			
Service menu	Thermistor adjustment	-10°C — +10°C	0°C				
	Auxiliary setting	Economy setting for pump	Active/Not active	Active			
		Freeze stat function	Time before pump switched off (3 – 60 mins)*1	10 mins			
		Electric heater (Heating)	Outdoor ambient temperature (3 – 20°C)	5°C			
		Electric heater (DHW)	Space heating: Used/Not Used	Used			
	Heat source setting	Electric heater (Heating)	Electric heater delay timer (5 – 180 mins)	30 mins			
		Electric heater (DHW)	DHW: Used/Not Used	Used			
		Electric heater (DHW)	Electric heater delay timer (15 – 30 mins)	15 mins			
		Standard/Heater	Standard/Heater	Standard			
	Operation setting	Simultaneous operation	Active/Inactive	Inactive			
		Cold weather function	Outdoor ambient temperature (-15 – 10°C)	-15°C			
		Cold weather function	Active/Inactive	Inactive			
		Cold weather function	Outdoor ambient temperature (-15 – -10°C)	-15°C			
		Room temp control (Heating)	Temperature control interval (10 – 60 mins)	10 mins			
		Room temp control (Heating)	Flow temperature range (Maximum temp.) (35 – 60°C)	50°C			
	Room temp control (Heating)	Flow temperature range (Minimum temp.) (25 – 40°C)	30°C				

\*1 Decreasing "time before pump switched off" may increase the duration of stand-by in Heating mode.



## Annual Maintenance Log Book

Contractor name		Engineer name	
Site name		Site number	

Cylinder maintenance record sheet			
Warranty number		Model number	
		Serial number	
No.	Mechanical	Frequency	Notes
1	Turn OFF water supply, drain tank, remove mesh from strainer clean and replace in strainer. *1		
2	Keep water supply OFF, open hot water taps and check the expansion vessel charge pressure. Top up if necessary (1 bar).		
3	Turn water supply ON, open the pressure relief valve and then the expansion valve in turn. Check for unrestricted discharge to the tundish and that the valves reseal correctly. Check there are no blockages in the tundish and associated pipe work.		
4	In hard water areas de-scaling of the immersion heaters may be required.		
5	Drop the primary/heating system pressure to zero check and if necessary top up the expansion vessel (1 bar). Air valve of expansion vessel is TR-412.		
6	Check and if necessary top up the concentration of anti-freeze/inhibitor (if used in the system).		
7	Top up the primary/heating system using an appropriate filling loop and re-pressurise to 1 bar.		
8	Heat system and check pressure does not rise above 3 bar and no water is released from the safety valves.		
9	Release any air from the system.		
10	To check the 3-way valve for inside leaks, confirm that the temperature of the heat emitter does not rise when running the DHW mode.		
Refrigerant SA models only		Frequency	Notes
1	Refer to outdoor unit manual.		
Electrical		Frequency	Notes
1	Check condition of cables.		
2	Check rating and fuse fitted on the electricity supply.		
Controller		Frequency	Notes
1	Check field settings against factory recommendations.		
2	Check operation of motorized valves ensure they reseal correctly.		
3	Check battery power of wireless thermostat and replace if necessary.		
Outdoor heat pump unit maintenance record sheet			
Model number		Serial number	
	Mechanical	Frequency	Notes
1	Inspect grill, heat exchanger fins air inlet for trapped debris/damage.		
2	Check condensate drain provision.		
3	Check integrity of water pipe work and insulation.		
4	Check all electrical connections.		
5	Check and record the operation voltage.		

\* All the above checks should be carried out once a year.

\*1. Be sure to reattach the mesh after washing.

**Note:**  
**Within the first couple of months of installation, remove and clean the strainer. This is especially important when installing on an existing system.**

In addition to annual servicing it is necessary to replace or inspect some parts after a certain period of system operation. Please see tables below for detailed instructions. Replacement and inspection of parts should always be done by a competent person with relevant training and qualifications.

### Parts which require regular replacement

Parts	Replace every	Possible failures
Pressure relief valve (PRV) Air vent (Auto/Manual) Drain cock (Primary circuit) Flexible hose Manometer Inlet control group (ICG)*	6 years	Water leakage due to brass/copper corrosion (Dezincification)

\* OPTIONAL PARTS for UK

### Parts which require regular inspection

Parts	Check every	Possible failures
Immersion heater	2 years	Earth leakage causing circuit breaker to activate (Heater is always OFF)
Pump	20,000 hrs (3 years)	Pump failure

### Parts which must NOT be reused when servicing

- \* O-ring
- \* Gasket

Note:  
 Always replace the gasket for pump with a new one at each regular maintenance (every 20,000 hours of use or every 3 years).







HEAD OFFICE : TOKYO BLDG., 2-7-3, MARUNOUCHI, CHIYODA-KU, TOKYO 100-8310, JAPAN

---