

TECHNICAL MANUAL/ MANUAL TÉCNICO

Air/water chillers and heat pumps and condensing units with scroll compressors.

Enfriadoras y bombas de calor aire agua y motocondensadores con compresores scroll.

NRC



INRCTV
0711
4572605_00

INSTRUCTIONS FOR THE SELECTION

Compliance declaration.....	2
1 General standards.....	pag. 3
1.1 Technical plate	pag. 3
2 Description and choice of unit	pag. 4
2.1 Models available	pag. 4
2.2 Versions available.....	pag. 4
2.2.1 Standard equipment	pag. 4
2.3 Selection.....	pag. 4
3 Description of components.....	pag. 5
3.1 Refrigerating circuit.....	pag. 5
3.2 Frame and fans.....	pag. 5
3.3 Hydraulic components.....	pag. 6
3.4 Safety and control components.....	pag. 7
3.5 Electrical components.....	pag. 7
3.6 Electronic regulation	pag. 7
4 Accessories	pag. 8
5 Technical data.....	pag. 10
5.1 Nominal reference conditions	pag. 10
5.2 Technical data standard versions (°).....	pag. 11
5.3 Technical data silenced versions (L)	pag. 13
5.4 Technical data heat pump versions (H).....	pag. 15
6 Selection criteria	pag. 17
6.1 Operating limits.....	pag. 17
6.2 Project data.....	pag. 17
7 Correction coefficients	pag. 18
7.1 Cooling and input capacities.....	pag. 18
7.2 Heating and input capacities.....	pag. 18
7.3 For Δt other than nominal	pag. 19
7.4 Correction factors for Δt other than nominal, chiller.....	pag. 20
7.5 Fouling factors.....	pag. 20
7.5.1 Fouling factors	pag. 20
8 Ethylene glycol solution	pag. 21
8.1 How to read the glycol curves.....	pag. 21
9 Pressure drops.....	pag. 23
9.1 Pressure drops evaporator.....	pag. 23
9.1.1 Coefficient for data other than nominal.....	pag. 23
9.2 Pressure drops, water filter.....	pag. 24
9.3 Filter characteristics.....	pag. 24
10 Storage tank.....	pag. 25
10.1 Calibration of expansion tank.....	pag. 25
11 Effective pressure for the system	pag. 26
11.1 Low pressure pumps	pag. 26
11.2 High pressure pumps	pag. 26
12 Desuperheaters.....	pag. 27
12.1 Standard version.....	pag. 27
12.1.1 Low noise version.....	pag. 27
12.1.2 Standard nominal data version/low noise version/heat pump version.....	pag. 27
12.2 Values different from the nominal value	pag. 28
12.3 Pressure drops.....	pag. 28
12.4 Desuperheater pressure drop	pag. 28
13 Total recovery	pag. 29
13.1 Pressure drops.....	pag. 29
13.1.1 Values different from the nominal value	pag. 29
13.1.2 Pressure drops.....	pag. 30
13.1.3 Total recovery filter pressure drops	pag. 30
14 Fan unit.....	pag. 30
14.1 Motor size and fixed pulley for fan unit (version standard)	pag. 30
14.2 Motor size and fixed pulley for fan unit (low noise models).....	pag. 32
15 Sound data	pag. 33
16 Capacity control.....	pag. 35
16.1 Standard versions	pag. 35
16.2 Heat pump versions.....	pag. 35
17 Calibration of check and safety parameters	pag. 36
17.1 Check parameters	pag. 36
18 Dimensions.....	pag. 37
18.1 Dimension tables.....	pag. 37
18.2 Minimum technical clearances.....	pag. 37
19 Weights and centres of mass	pag. 38

Dear Customer,

Thank you for choosing AERMEC. It is the fruit of many years of experience and special design studies and has been made of the highest grade materials and with cutting edge technology.

In addition, all our products bear the EC mark indicating that they meet the requirements of the European Machine Directive regarding safety. The standard of quality is permanently being monitored and AERMEC products are therefore a synonym for Safety, Quality and Reliability.

The data may undergo modifications considered necessary for the improvement of the product, at any time and without the obligation for any notice thereof.

Thank you again.
AERMEC S.p.A



AERMEC S.p.A.
I-37040 Bevilacqua (VR) Italia - Via Roma, 44
Tel. (+39) 0442 633111
Telefax 0442 93730 - (+39) 0442 93566
www.aermeccom - info@aermeccom

NRC NRC H

SERIAL NUMBER:	
-----------------------	--

DECLARATION OF CONFORMITY

We, the undersigned, declare on our own exclusive responsibility that the object in question, so defined:

NAME

NRC

TYPE

AIR / WATER CHILLER, HEAT PUMP NRC RANGE

is in compliance with:

MODEL

The model this declaration refers to complies with the following harmonised standards:

CEI EN 61000-6-2

Immunity and electromagnetic emissions for industrial environments

CEI EN 61000-6-4

EN378

Refrigerating system and heat pumps - Safety and environmental requirements

EN12735

Copper and copper alloys - Seamless, round copper tubes for air conditioning and refrigeration

UNI1285-68

Calculation of the strength of metal pipes subjected to internal pressure

EN60204-1

Machinery safety - Electrical equipment of machinery

Thus also complying with the basic requirements of the following directives:

- LVD Directive: 2006/95/CE
- Electromagnetic compatibility directive 2004/108/CE
- Machine Directive 98/37/CE
- PED Directive regarding pressure-operated equipment 97/23/CE

The product, pursuant Directive 97/23/EC, meets the Total Quality Warranty procedure (module H) with the certificate No. 06/270-QT3664, Rev.0 issued by the notified body No. 1131 CEC via Pisacane 46 Legnano (MI) - Italy

Bevilacqua

26/03/2007

Marketing Director
Signature

1 GENERAL STANDARDS

- This manual, and the electrical layouts supplied with the unit, must be kept in a dry place for any future consultation, and for the lifespan of the machine.
- This manual has been drawn up with the aim of supporting the correct installation of the unit and providing all the indications for the correct use and maintenance of the device. Before proceeding with the installation, please read all the information in the manual carefully, as well as the procedures necessary for the correct installation and use of the unit.
- Be careful to adhere to the instructions in this manual and observe the safety regulations currently in place.
- The device must be installed in compliance with the local legislation currently in force in the country of destination.
- Non-authorized tampering with the equipment, whether electrical or mechanical, will make **THE WARRANTY VOID and exclude any liability on the part of the company.**
- Check the electrical characteristics shown on the registration plate (fig.1) before making the electrical connections. Read the instructions in the specific section about electrical connections.

- If the unit needs to be repaired, in all cases contact a specialised AERMEC After Sales Service centre and only use OEM spare parts.
- The manufacturer furthermore declines any liability for injury to persons or damage to things resulting from the failure to comply with the information in this manual.
- Permitted uses: this series of chillers is suitable for producing cold water to use in hydronic systems designed for air conditioning. The units are not suitable for producing hot water for bathrooms.
Any use other than that permitted, or outside the operating limits mentioned in this manual, is forbidden unless previously agreed with the company.
The warranty does not include payment for damage due to wrong installation of the unit by the installer.
- The warranty does not include payment for damage due to the improper use of the unit by the user.
- The manufacturer is not to be considered liable for accidents to the user or the installer due to the incorrect installation or improper use of the unit.
- The device must be installed in such a way that maintenance and/or repair operations can be carried out. The

warranty of the device does not in any case cover costs incurred as a result of motorised ladders, scaffolding or any other lifting systems necessary to carry out the operations under warranty.

The warranty is not valid when:

- the services and repairs have been carried out by non-authorized personnel or companies;
- the unit has been repaired or modified in the past with non-OEM spare parts;
- the unit has not been adequately maintained;
- the instructions described in this manual have not been followed;
- non-authorized modifications have been made.

N.B:

The Manufacturer reserves the right at all times to make any modification for the improvement of its product, and is not obliged to add these modification to machines of previous manufacture that have already been delivered or are being built.

The warranty conditions are anyway subject to the general sales conditions at the moment the contract is finalised.

1.1 Technical plate

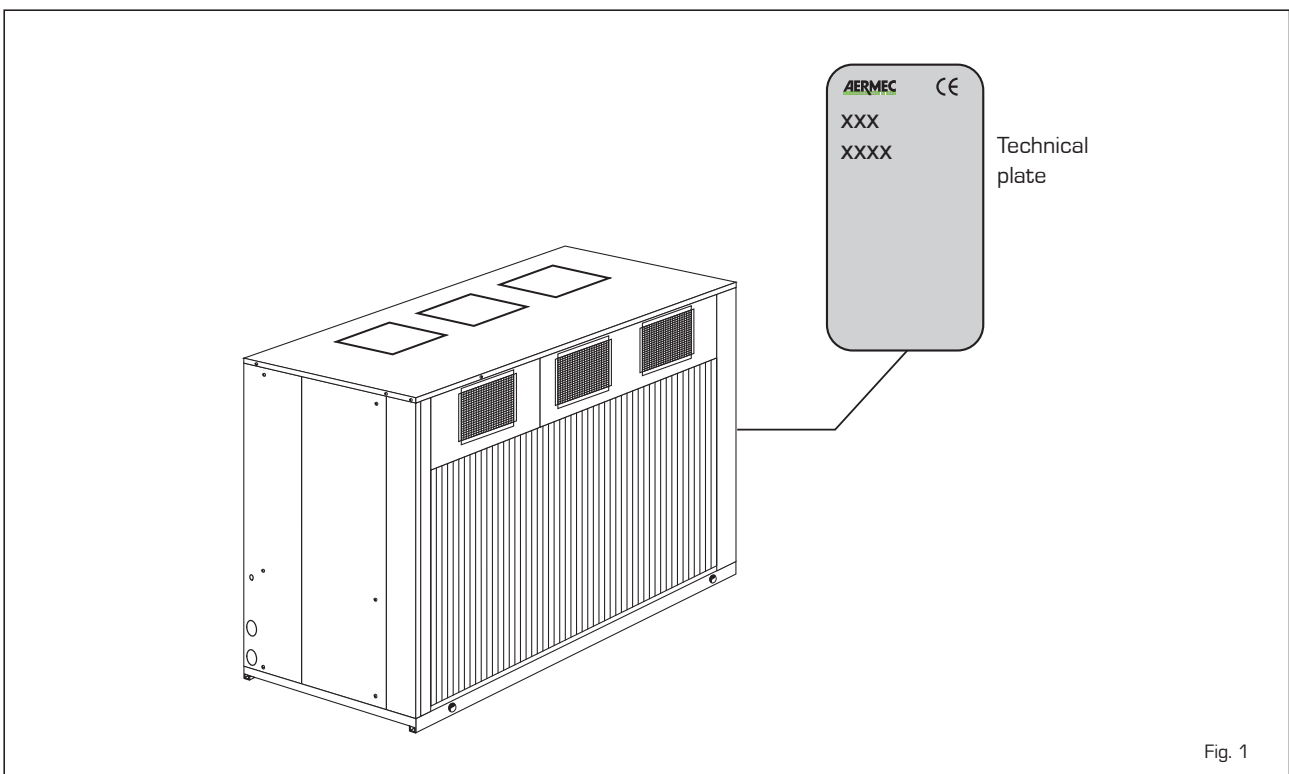

2 DESCRIPTION AND CHOICE OF UNIT

The appliances in the NRC series are used to produce cold water for technological systems, these appliances are for indoor installation, the heat pump models allow the production of hot water for heating purposes. They consist of two R407C refrigerating circuits and a single hydraulic circuit (which may or may not be fitted with an storage tank unit or additional pump kit).

The presence of a number of scroll type compressors enables NRC refrigerators to partialise cooling capacity in various ways (up to 4 step capacity control). Electronic regulation using a microprocessor controls and manages all the units operating parameters and components; an internal memory records the operating conditions every time an alarm is triggered, so that they can be visualised on the display. The units have a protection rating of IP 24.

2.1 MODELS AVAILABLE

- STANDARD (°) this is the most economic configuration, which is obtained by calibrating the finned heat exchanger banks to allow proper operation of the refrigerator at external air temperatures not exceeding 46°C.
- LOW NOISE (L) this indicates models configured for particularly low noise operation. Sound absorbent covers are applied to the compressor to reduce their noise. Moreover, they are equipped with adjusted fan group to

reduce their air flow and noise compared to the basic model.

- HEAT PUMP STANDARD (H) in cooling mode the operating limits arrive to a maximum outside air temperature of 46°C.

2.2 VERSIONS AVAILABLE

- "HEAT RECOVERY"

The heat that is released into the air by NRC appliances through their condenser cells, can be partially or totally recovered by a special heat exchanger, to provide hot water for sanitary or other purposes. The machine can be set up for heat recovery, should this need be felt.

There are two alternatives:

1. Desuperheater (D)

NB: in the heat pump versions, the desuperheater must be intercepted during heat pump operation: otherwise, the guarantee will no longer be considered valid.

2. Total heat recovery (T)

NB: envisaged only in cooling only versions (not available for heat pumps and air-cooled units).

- "CONDENSING UNITS C"
- "SILENCED CONDENSING UNITS LC"

NB:

the air-cooled versions are available for the cooling only versions.

- "VERSION Y" is the version that allows you to produce chilled water below the standard value of +4°C, to a minimum of -6°C. For lower values, contact the company headquarters.

NB:

The model is only available for cooling only versions.

WARNING

For the devices designed to work with a low air temperature, and also the heat pumps, before starting up the unit (or at the end of each period of prolonged disuse) it is extremely important for the oil of the compressor carter to be heated beforehand, via the power supply to the special heaters, for at least 8 hours.

The carter heater is automatically powered when the unit stops, provided that the unit is kept under tension.

2.2.1 Standard equipment

ALL THE VERSIONS COME WITH:	
1.	Evaporator anti-freeze heater
2.	Compressor carter heater
3.	Remote control panel
4.	Water filter (supplied with the versions without storage tank)
5.	Differential pressure switch
6.	High pressure transducer as standard in models from 500 to 1000 (cooling only)
7.	High pressure switch
8.	Low pressure switch (standard on cooling only models)

HEAT PUMPS	
TP1	Low pressure transducer
TP2	High pressure transducer

CHILLERS WITH STORAGE TANK	
1.	Evaporator anti-freeze heater
2.	High or low pressure pumping unit
3.	The pumping unit of the chillers with storage tank tank may be high or low pressure, and has an optional reserve pump (managed by the electronic card) that periodically rotates the pumps in order to optimise their working hours.
4.	For the heat pump versions, an storage tank (pre-set for the insertion of integrative heaters) is available upon request.

NB:

only the heat pump versions envisage the possibility to work with various RX supplementary heaters. Their purchase, assembly and connection will be the responsibility of the user. Remember also that the relevant holes for such heaters are fitted with provisional plastic caps. If electric heaters (with their relative closure) are not initially used, the plastic caps must be replaced with metal ones.

2.3 SELECTION

1,2,3	4,5,6,7	8	9	10	11	12	13	14	15,16
NRC	0500	°	°	D	L	°	°	°	00

fields 1, 2 e 3: **NRC**

NOTES:

(1) = For the configuration of these versions, you are advised to contact the head office.

(2) =Only the heat pump versions envisage the possibility to work with various RX supplementary heaters; their purchase, assembly and connection will be the responsibility of the user. Remember also that the relevant holes for such heaters are fitted with provisional plastic caps. If electric heaters (with their relative closure) are not initially used, the plastic caps must be replaced with metal ones.

fields 15 - 16

fields 14

fields 13

fields 12

fields 11

fields 10

fields 9

fields 8

fields 4 - 5 - 6 - 7

HYDRONIC KIT	
00	Without storage tank
01	Storage tank and low pressure pump
02	Storage tank, low pressure pump and reserve pump
03	Storage tank and high pressure pump
04	Storage tank, high pressure pump and reserve pump
05	Storage tank with holes for integrative resistance, and low pressure pump (2)
06	Storage tank with holes for integrative resistance, low pressure pump and reserve pump (2)
07	Storage tank with holes for integrative resistance, high pressure pump (2)
08	Storage tank with holes for integrative resistance, high pressure pump and reserve pump (2)
P1	Only low pressure pump
P2	Low pressure pump and reserve pump
P3	Only high pressure pump
P4	High pressure pump and reserve pump

Power supply	
°	3N~400V-50Hz; with thermomagnetic switches (up to version 0750)
	3~400V-50Hz; with thermomagnetic switches (up to version 0800)
4	3~230V-50Hz; with thermomagnetic switches(1)
9	3~500V-50Hz; with thermomagnetic switches (1)

Evaporator	
°	According to PED standards
G	According to TÜV-D (Germany) standards
C	Condensing (without evap.) (cooling only)

Coils	
°	Aluminium
R	Copper
S	Tinned copper
V	Varnished aluminium copper

Version	
°	Standard
L	Standard in Silenced operation (Cooling only)

Heat recoverers	
°	Without recoverers
D	Desuperheater (1)
T	Total recovery (Cooling only) (1)

Model	
°	Cooling only
H	Heat pump

Field of use	
°	Standard
Y	Version for low temperature of processed water, down to -6°C (1)

Size	
0275 • 0300 • 0325 • 0350 • 0500 • 0550 • 0600 • 0650 • 0700 • 0750 • 0800 • 0900 • 1000	

3 DESCRIPTION OF COMPONENTS

Componenti principali



LEGENDA

- 1 Compressor
- 2 Water side exchanger
- 3 Air side exchanger
- 4 Frame
- 5 Control keypad
- 6 Fan assembly
- 7 Storage tank
- 8 Expansion tank
- 9 Filter
- 10 Flow switch
- 11 Safety valve
- 12 Drain valve
- 13 Door interlock system
- 14 Remote panel

3.1 REFRIGERATING CIRCUIT

Compressore

Hermetic scroll type compressors, fitted with an antifreeze resistor as standard accessory. The resistor is powered automatically when the unit pauses, provided the power supply is not turned off. In the silenced version L, the compressor compartment is soundproofed.

Exchanger air side

Made of aluminium fins mechanically bonded to copper pipes.

Exchanger water side

Plate type (AISI 316), with double cooling circuit and alternating water-freon circuits. Insulated externally with closed cell material, to reduce heat loss. Equipped with standard anti-freeze electric heater.

Liquid separator (heat pump versions only)

Located on the compressor suction side to offer protection against possible returns of liquid refrigerant, flooded starting, and operation in the presence of liquid.

Thermostatic valve

The valve, with equaliser at the evaporator outlet, regulates gas flow to the evaporator according to the thermal load, ensuring a sufficient degree of superheating of intake gas.

Drier filter

Mechanical filter made from ceramic and hygroscopic material, designed to capture impurities and all residual moisture in the

cooling circuit.

Liquid indicator

Indicates the level of the coolant gas charge and the presence of moisture in the cooling circuit.

Solenoid valve

Cuts in when the compressor shuts down to stop flow of coolant gas to the evaporator.

Suction side liquid

These valves provide the facility to intercept the flow of refrigerant to allow supplementary maintenance work to be carried out.

Reverse cycle valve (heat pump only)

Reverses the flow of coolant on changing from Summer to Winter operating mode and during defrosting cycles.

Cooling circuit safety valve

Set to 30 Bar, it intervenes to discharge excess pressure if the pressure level rises above normal.

Unidirectional valve

Allows refrigerant to flow in only one direction. Only for heat pump and total heat recovery units.

Liquid storage tank (only for heat pump versions or units with total heat recovery)

Located on the compressor suction side to offer protection against possible returns of liquid refrigerant, in case in that particular operation mode, it exceeds the standard level.

3.2 FRAME AND FANS

Frame

Made from hot-galvanised thick sheet metal, painted with stoved polyester powder for resistance to atmospheric agents.

Fan assembly

Statically and dynamically balanced centrifugal fans, connected to the motor by an adjustable pulley. The fan motor has a circuit breaker protection. A safety guard has been fitted to the top of the housing. In the low noise version (L) the fan group is adjusted in order to reduce its noise level.

Door lock disconnecter

For safety's sake it is only possible to access the electric panel after cutting off the power supply using the lever that opens the panel itself. This lever can be fastened with one or more locks during maintenance operations, to prevent power from being restored to the machine accidentally.

3.3 HYDRAULIC COMPONENTS

Differential pressure switch

It is mounted across the inlet and outlet of the exchanger and, in the event that the water flow is too low, it blocks the compressor. It is included in are models without buffer tank and/or pump.

Flow switch

Has the job of checking the circulation of water. If there is no circulation, it blocks the unit. It is included in are models with buffer tank and/or pump.

Circulation pump

Provides the head required to compensate for pressure drops in the system. The option of a reserve pump is also foreseen.⁽²⁾

Water filter

Assembled as standard on versions with storage tank tank, it allows you to block and eliminate any impurities in the hydraulic circuits. Inside, it has a filtering mesh with holes no bigger than one millimetre. It is essential for avoiding serious damage to the plate heat exchanger. For versions without storage tank tank and/or pump, it is supplied as standard equipment. Its installation is compulsory, otherwise the guarantee will no longer be considered valid.

Storage tank ⁽¹⁾

Steel tank with 500-litre capacity (Sizes 0800-0900-1000 are fitted with 700-litre capacity). To reduce heat loss and eliminate the formation of condensation, it is insulated with layer of polyurethane material of adequate thickness. Equipped as standard with an electric antifreeze heater (until -20 °C external temperature - water tank temperature 5 °C) controlled by the antifreeze sensor located in the tank⁽³⁾.

Bleed valve

Automatic valve, discharges residual air present in tank. It is intercepted by a tap to facilitate replacement when necessary. For versions with buffer tank and pumps.

Filling assembly

Features pressure gauge for measuring system pressure values. It is not included in are models without buffer tank and/or pump.

Expansion vessel

Diaphragm type pre-charged with nitrogen. It is included in are models with buffer tank, and models with pump.

(1) = Hydraulic circuit component only present in units with storage tank.

(2) =The spare pump is controlled by the electronic card. The pumps can be high or load head.

(3) = **Heat pump versions only can be prearranged to have RX additional heaters fitted. The RX has to be purchased, mounted and connected by the user. Please bear in mind that the holes for the RX heater are equipped with provisional plastic protection. In case the heater and its protection is not installed initially, all plastic protections have to be replaced by metal ones.**

Hydraulic circuit safety valve

Set to 6 Bar with ductable discharge, it intervenes to discharge excess pressure if the pressure level rises above normal. It is not included in are models without buffer tank and/or pump.

3.4 SAFETY AND CONTROL COMPONENTS

Electric panel

Features power section, regulation of controls and safety devices. Compliant with CEI 60204-1 standards and Directives EMC 89/336/CEE and 92/31/CEE governing electromagnetic compatibility.

Control keypad

Gives complete control over unit functions. For more information, refer to the user manual.

Remote control panel (standard accessory)

It allows the following operations to be remote controlled:

- ON / OFF of the unit (signaled by a yellow light);
- Selection of summer / winter operating modes (signaled by green / red lights);
- Summation alarm through a red light.

In the event of an alarm signal, the unit can be reset through the remote control by pressing the ON/OFF switch.

The connection between the unit and the panel is made by means of a 6 pole cable with a section of: 0,5 mm² (max. 50 m), 1 mm² (max. 100 m).

Anti-freeze electric heater evaporator (Supplied as a standard accessory)

This is turned on by the antifreeze probe, located in the plate evaporator. It turns on when the water temperature drops to +3°C and turns off again when the temperature reaches +5°C. The resistor is managed by a dedicated software, resident in the regulation card.

High pressure switch (Supplied as a standard accessory)

Variable setting, located on the high pressure side of the cooling circuit, the switch shuts compressor operation in the event of abnormal operating pressure levels.

Low pressure switch ⁽³⁾

Fixed setting, located on the low pressure side of the cooling circuit, the switch shuts down compressor operation in the event of abnormal operating pressure levels.

(3) = Not included in the heat pump version.

- compressor thermal-magnetic circuit breaker;
- fan thermal-magnetic circuit breaker;
- auxiliary thermal-magnetic circuit breaker;
- compressor guard heater;
- **Low pressure transducers (TP1): standard option for heat pump versions**
- **High pressure transducer (TP2): standard option for heat pump versions and on NRC 0500 - 0550 - 0600 - 0650 - 0700 - 0750 - 0800 - 0900 - 1000 cooling only.**
- discharge gas temperature control thermostat;

3.5 ELECTRICAL COMPONENTS

Electric panel

Features power section, regulation of controls and safety devices. Compliant with CEI 60204-1 standards and Directives EMC 89/336/CEE and 92/31/CEE governing electromagnetic compatibility.

3.6 ELECTRONIC REGULATION

Microprocessor card

Consisting of a management/control card and a visualisation card. Functions carried out:

- regulation of evaporator water inlet temperature (also outlet can be selected), with thermostat action up to 12 levels and proportional/integral control of fan speed.
- delayed compressor start-up.
- operation as chiller; with possibility to integrate refrigerating capacity by means of "free-cooling".
- compressor sequence rotation.
- management of low temperature device (accessory).
- compressor operation hour count.
- start/stop.
- reset.
- permanent alarms memory.
- automatic start-up after drop in voltage.
- multi-lingual message service.
- operation with local or remote control.
- visualisation of machine status: ON/OFF compressors; alarms summary.
- alarms management: high pressure; flow switch; low pressure; anti-freeze; compressor overload; fan overload; pump overload.
- visualisation of the following parameters: water inlet temperature; evaporator water inlet temperature;

- water outlet temperature; delta T;
- high pressure; low pressure;
- waiting time for restart.
- alarms visualisation.
- settings:
 - a) without password:
 - cooling set;
 - total differential;
 - b) with password:

- anti-freeze set;
- low pressure exclusion time;
- display language;
- access code.

For further information, refer to the user manual.

4 ACCESSORIES

DR 200 / 400 - Low temperature control

This accessory is only available for the heat pump versions. It ensures the correct operation of the unit in cooling with ambient temperatures below 19 °C down to -10 °C. It is constructed with a damper that, combined with the high pressure transducer TP (standard on the unit), in base to the condensing pressure, it modulates the air flow to the condenser to maintain the pressure sufficiently high. The microprocessor card also excludes the low pressure switch during the start-up phase.

DR 202 / 402 - Low temperature control

This accessory is only available for the cooling only versions. It ensures the correct operation of the unit in cooling with ambient temperatures below 19 °C down to -10 °C. It is constructed with a damper that, combined with the high pressure transducer TP (included in the kit; two for DR 202 and 402), in base to the condensing pressure, it modulates the air flow to the condenser to maintain the pressure sufficiently high.

PGS - Daily/weekly programmer

Programmer for installation on unit electrical board. Programs two daily operation cycles (ON/OFF); can be used to program daily operation of the unit.

ROMEO - Remote Overwatching Modem Enabling Operation

(Remote Overwatching Modem Enabling Operation) is a device that enables a remote control of a chiller from an ordinary mobile phone with WAP browser. Furthermore it allows to send alarm or pre-alarm SMS up to 3 GSM mobile phones which may not be equipped with WAP browser.

TP 1 - Low pressure transducer

Standard equipment on heat pump models. Serves to show the compressor suction pressure value on the microprocessor board display (one per circuit). Located on the low-pressure side of the refrigerant circuit, disconnects the compressor if anomalous working pressures are detected.

ous working pressures are detected.

TP 2 - High pressure transducer Standard on sizes 0500, 0550, 0600, 0650, 0700, 0750, 0800, 0900, 1000 and on all heat pump models.

Serves to show the compressor discharge pressure value on the microprocessor board display (one per circuit). This adjustable sensor located on the high-pressure side of the refrigerant circuit disconnects the compressor if anomalous working pressures are detected.

VT - Antivibration feet

Group of four antivibration feet to be installed under the sheet metal base of the unit, in the holes provided, and are extremely useful in muffling the vibrations produced by the operation of the fans and compressors

AVX - Vibration damper supports

Spring vibration damper supports. Select model AVX on the compatibility table.

AER485 - MODBUS system board

Accessory for connecting the unit to BMS supervisor systems with electric standard RS485 and MODBUS protocol.

DRE-PEAK current reducer

It reduces the peak current at the startup of the unit. Accessory to be applied in the factory.

RIF - Current rephaser

Parallel connection with the motor makes the reduction of input current possible. This can only be installed when the machine is being made and must therefore be specified when the order is placed. Accessory to be applied in the factory.

Dualchiller - Simplified control system for control, switch-on and switch-off of two chillers, with Aermec GR3 control, in the same plant as if they were a single unit.

Multichiller - Control system for con-

trol, switch-on and switch-off of the single chillers in a plant in which multiple units are installed in parallel, always ensuring constant flow to the evaporators.

ACCESSORIES COMPATIBILITY TABLE

	0275	0300	0325	0350	0500	0550	0600	0650	0700	0750	0800	0900	1000
AER485	•	•	•	•	•	•	•	•	•	•	•	•	•
DUALCHILLER	•	•	•	•	•	•	•	•	•	•	•	•	•
MULTICHILLER	•	•	•	•	•	•	•	•	•	•	•	•	•
AVX 401							•	•					
AVX 402							• (*)	• (*)	•	•			
AVX 403									• (*)	• (*)			
AVX 404											•	•	
AVX 405													•
AVX 406											• (*)	• (*)	
AVX 407													• (*)
DR200	• (**)	• (**)	• (**)										
DR400				• (**)	• (**)	• (**)							
DR202	•	•	•										
DR402				•									
DR600							•	•	•	•			
DR800											•	•	•
DRE275	•												
DRE300		•											
DRE325			•	•									
DRE 10					• (x2)	•	• (x2)						
DRE 15					•	• (x2)	• (x2)	• (x4)	• (x4)	• (x2)			
DRE 25										• (x2)	• (x4)	• (x2)	
DRE 30												• (x2)	• (x4)
PGS	•	•	•	•	•	•	•	•	•	•	•	•	•
RIF 62	•	•	•										
RIF 82				•									
RIF 63					•	•							
RIF 64							•	•	•	•	•		
RIF 74												•	
RIF 84													•
ROMEO	•	•	•	•	•	•	•	•	•	•	•	•	•
TP1	• (x2) ***	• (x2) ***	• (x2) ***	• (x2) ***	• (x2) ***	• (x2) ***	• (x2) ***	• (x2) ***	• (x2) ***	• (x2) ***	• (x2) ***	• (x2) ***	• (x2) ***
TP2	• (X2) ***	• (X2) ***	• (X2) ***	• (X2) ***									
VT14 *				•	•	•							
VT16 *	•	•	•										
VT17					•	•							
VT2	•	•	•	•									

DR = accessory compulsory in D versions.

(*) = to be used in versions with storage tank tank.

(**) = to be used in heat pump versions.

(***) = standard in heat pump versions.

The numbers in brackets show the quantity necessary.

N.B.: remember that the pump-only versions use the same anti-vibration mounts as the basic version.

5 TECHNICAL DATA

5.1 Nominal reference conditions

The technical data is calculated as follows

Cooling mode

- Temperature water inlet	12 °C
- Temperature of processed water	7 °C
- Ambient air temperature	35 °C
- Δt	5 °C

Heating mode

- Temperature of processed water	50 °C
- Ambient air temperature	b.s. 7 °C b.u. 6 °C
- Δt	5 °C

Sound Power

Aermec determines the value of sound power on the basis of measurements performed in compliance with regulation 9614, in respect with that requested by Eurovent certification.

(1) **Sound Pressure**

Sound pressure in free field on a reflective surface (factor of directionality G=2), at 10 metres from the external surface of the unit, using the parallel expansion method (box-method, ISO 3744)

NOTE

- The noise data refer to configuration without pump.
- For heat pumps the data refers to functioning in cooling mode

E.S.E.E.R.

There is a growing awareness in Europe as well that attention needs to be paid to the electricity consumed by air conditioning machines. For many years now in the United States talk has not just been about efficiency in the plan conditions, but an assessment index is used that takes account of the marginal operation of the unit under plan conditions and the greater use with partial loads with external air that is less than that planned and in conditions

of compressor capacity control. In Europe the proposed EECCAC (Energy Efficiency and Certification of Central Air Conditioner) has been adopted, the ESEER (European Seasonal Energy Efficiency Ratio), that has the purpose of being able to compare the chillers with each other.

After estimating the total energy required by the system during summer management (kW/h), the seasonal electrical energy consumption can be deduced with this formula:

$$\text{Input energy} = \frac{\text{Required energy}}{\text{Efficiency index}}$$

The actual energy calculation can be obtained, more accurately, by considering:

1. The load profile with external temperature
2. The climatic profile
3. The total number of hours

With this data, every consultant or designer will be able to his or her evaluations.

$$\text{ESEER} = (3 \times \text{EER}_{100\%} + 33 \times \text{EER}_{75\%} + 41 \times \text{EER}_{50\%} + 23 \times \text{EER}_{25\%}) / 100$$

Evaporator outlet water				7 °C
ΔT at full load				5 °C
Load	100%	75%	50%	25%
External air temperature	35 °C	30 °C	25 °C	20 °C

5.2 TECHNICAL DATA STANDARD VERSIONS (°)

NRC°		0275	0300	0325	0350	0500	0550
Cooling capacity:	kW	51,0	59,0	67,0	76,0	89,0	97,0
Total input power	kW	22,0	26,1	29,4	32,3	37,6	40,4
Evaporator water flow rate	l/h	8770	10150	11520	13070	15310	16680
Evaporator pressure drop	kPa	37,0	32,2	31,6	43,0	27,6	22,4
ENERGY INDICES							
EER	W/W	2,32	2,26	2,28	2,35	2,37	2,40
ESEER	W/W	2,59	2,53	2,55	2,63	2,74	2,78
ELECTRICAL DATA							
Fuel feed	V	3N~400 V 50 HZ (versions 0275 - 0750), 3~400 V 50Hz (versions 0800 - 1000)					
Total input power	A	40,3	46,5	51,3	57,5	68,1	72,1
Maximum current	A	54	63	71	80	93	99
Peak current	A	153	161	165	208	219	223
COMPRESSORS							
Type		scroll	scroll	scroll	scroll	scroll	scroll
Number	n°	2	2	2	2	3	3
Number per circuit	n°+n°+n°+n°	2/2	2/2	2/2	2/2	3/2	3/2
COMPRESSOR HEATER							
Compressor carter heater	n°xW	2x75	2x75	2x75	2x75	3x75	3x75
FANS							
Type		centrifugal	centrifugal	centrifugal	centrifugal	centrifugal	centrifugal
Number	n°	2	2	2	2	2	2
Input current ventilation unit	A	4,5	7,8	8,5	5,8	7,3	7,3
Input power ventilation unit	kW	2,4	4,0	4,0	4,0	4,6	4,6
Air flow rate	m ³ /h	16000	22000	22000	26000	27000	27000
EVAPORATORS							
Type		plate	plate	plate	plate	plate	plate
Number	n°	1	1	1	1	1	1
HYDRAULIC CIRCUIT							
Water storage tank	lt	500	500	500	500	500	500
Storage tank anti-freeze heater	W	300	300	300	300	300	300
LOW PRESSURE PUMPING UNIT							
Input power	kW	0,75	0,75	0,75	0,75	1,10	1,10
Input current	A	1,85	1,85	1,85	1,85	2,14	2,14
Useful pressure pumping	kPa	127	127	122	104	131	126
HIGH PRESSURE PUMPING UNIT							
Input power	kW	1,10	1,10	1,50	1,50	1,85	1,85
Input current	A	2,14	2,14	2,92	2,92	3,60	3,60
Useful pressure pumping	kPa	178	173	168	154	195	193
SOUND DATA							
Sound Power	dB(A)	85	85	85,5	88,5	88	88
Sound pressure (1)	dB(A)	53	53	54	56	56	56
DIMENSIONS FOR ALL VERSIONS (without storage tank and pump)							
Height	mm	1763	1793	1793	1763	1963	1963
Width	mm	2100	2100	2100	2450	2450	2450
Length	mm	950	950	950	950	950	950
EMPTY WEIGHT versions without storage tank and pumps							
	kg	629	665	699	777	904	919

NOTE: for the plumbing connections, refer to the installation manual.

NRC°		0600	0650	0700	0750	0800	0900	1000
Cooling capacity:	kW	120	136	156	184	214	238	264
Total input power	kW	52,0	58,0	65,5	77,0	90,0	100,0	112,5
Evaporator water flow rate	l/h	20.640	23.390	26.830	31.650	36.810	40.940	45.410
Evaporator pressure drop	kPa	32,0	28,3	36,5	27,8	35,6	30,3	30,6
ENERGY INDICES								
EER	W/W	2,31	2,34	2,38	2,39	2,38	2,38	2,35
ESEER	W/W	3,0	3,05	3,0	3,11	3,19	3,19	3,19
ELECTRICAL DATA								
Fuel feed	V	3N~400 V 50 HZ (versions 0275 - 0750), 3~400 V 50Hz (versions 0800 - 1000)						
Total input power	A	93,4	101,5	117,0	134,5	153,7	171,7	193,2
Maximum current	A	131	143	164	190	225	245	277
Peak current	A	207	215	267	318	337	404	424
COMPRESSORS								
Type		scroll	scroll	scroll	scroll	scroll	scroll	scroll
Number	n°	4	4	4	4	4	4	4
Number per circuit	n°+n°+n°+n°	4/2	4/2	4/2	4/2	4/2	4/2	4/2
COMPRESSOR HEATER								
Compressor carter heater	n°xW	4 x 75	4 x 75	4 x 75	2x75 2x130	4 x 130	4 x 130	4 x 130
FANS								
Type		centrifugal	centrifugal	centrifugal	centrifugal	centrifugal	centrifugal	centrifugal
Number	n°	3	3	3	3	4	4	4
Input current ventilation unit	A	17,4	17,4	18,5	21,9	27,1	31,7	38,0
Input power ventilation unit	kW	9,9	9,9	10,5	12,45	15,4	18	21,6
Air flow rate	m ³ /h	45.000	45.000	50.000	50.000	60.000	68.000	68.000
EVAPORATORS								
Type		Plate	Plate	Plate	Plate	Plate	Plate	Plate
Number	n°	1	1	1	1	1	1	1
HYDRAULIC CIRCUIT								
Water storage tank	lt	500	500	500	500	700	700	700
Storage tank anti-freeze heater	W	300	300	300	2x300	2x300	3x300	2x300
LOW PRESSURE PUMPING UNIT								
Input power	kW	1,1	1,5	1,85	1,85	3	3	3
Input current	A	2,14	2,92	3,6	3,6	6,2	6,2	6,2
Useful pressure pumping	kPa	69	85	103	100	97	95	82
HIGH PRESSURE PUMPING UNIT								
Input power	kW	3,7	3,7	3,7	3,7	5,5	5,5	5,5
Input current	A	7,21	7,21	7,21	7,21	11	11	11
Useful pressure pumping	kPa	177	163	146	166	215	212	195
SOUND DATA								
Sound Power	dB(A)	90	90	91	91	92	92,5	92,5
Sound pressure (1)	dB(A)	58,0	58,0	59,0	59,0	60,0	60,0	60,0
DIMENSIONS STANDARD (without storage tank and pump)								
Height	mm	2288	2288	2288	2288	2295	2295	2295
Width	mm	3750	3750	4550	4550	4950	4950	4950
Length	mm	1100	1100	1100	1100	1300	1300	1300
EMPTY WEIGHT versions without storage tank and pumps								
	kg	1481	1498	1737	1918	2670	2700	2960

NOTE: for the plumbing connections, refer to the installation manual.

5.3 TECHNICAL DATA SILENCED VERSIONS (L)

NRC L		0275	0300	0325	0350	0500	0550
Cooling capacity:	kW	46,0	54,0	62,0	70,0	81,0	89,0
Total input power	kW	22,7	26,3	29,7	33,1	40,0	43,0
Evaporator water flow rate	l/h	7910	9290	10660	12040	13930	15310
Evaporator pressure drop	kPa	30,3	27,0	27,1	36,5	22,6	19,0
ENERGY INDICES							
EER	W/W	2,03	2,05	2,09	2,11	2,03	2,07
ESSER	W/W	2,06	2,19	2,22	2,25	2,24	2,28
ELECTRICAL DATA							
Fuel feed	V	3N~400 V 50 HZ (versions 0275 - 0750), 3~400 V 50Hz (versions 0800 - 1000)					
Total input power	A	40,5	45,8	50,7	57,7	68,7	73,3
Maximum current	A	54	63	71	80	93	99
Peak current	A	152	158	163	206	217	221
COMPRESSORS							
Type		scroll	scroll	scroll	scroll	scroll	scroll
Number	n°	2	2	2	2	3	3
Number per circuit	n°+n°+n°+n°	2/2	2/2	2/2	2/2	3/2	3/2
COMPRESSOR HEATER							
Compressor carter heater	n°xW	2x75	2x75	2x75	2x75	3x75	3x75
FANS							
Type		centrifugal	centrifugal	centrifugal	centrifugal	centrifugal	centrifugal
Number	n°	2	2	2	2	2	2
Input current ventilation unit	A	2,4	4,1	4,2	3,2	3,9	3,9
Input power ventilation unit	kW	1,4	2,4	2,5	1,9	2,3	2,3
Air flow rate	m ³ /h	11000	15500	15500	18000	19000	19000
EVAPORATORS							
Type		plate	plate	plate	plate	plate	plate
Number	n°	1	1	1	1	1	1
HYDRAULIC CIRCUIT							
Water storage tank	lt	500	500	500	500	500	500
Storage tank anti-freeze heater	W	300	300	300	300	300	300
LOW PRESSURE PUMPING UNIT							
Potenza assorbita	kW	0,75	0,75	0,75	0,75	1,10	1,10
Corrente assorbita	A	1,85	1,85	1,85	1,85	2,14	2,14
Prevalenza utile	kPa	142	138	131	119	149	143
HIGH PRESSURE PUMPING UNIT							
Input power	kW	1,10	1,10	1,50	1,50	1,85	1,85
Input current	A	2,14	2,14	2,92	2,92	3,60	3,60
Useful pressure pumping	kPa	186	180	176	164	203	203
SOUND DATA							
Sound Power	dB(A)	81	81	82	84	84	84
Sound pressure (1)	dB(A)	49,0	49,0	50,0	52,0	52,0	52,0
DIMENSIONS VERSIONS STANDARD (without storage tank and pump)							
Height	mm	1763	1793	1793	1763	1963	1963
Width	mm	2100	2100	2100	2450	2450	2450
Length	mm	950	950	950	950	950	950
EMPTY WEIGHT versions without storage tank and pumps							
		638	674	708	786	917,5	932,5

NOTE: for the plumbing connections, refer to the installation manual.

NRC L		0600	0650	0700	0750	0800	0900	1000
Cooling capacity:	kW	110	126	142	168	194	216	238
Total input power	kW	47,5	54,0	62,0	72,5	83,0	94,0	104,5
Evaporator water flow rate	l/h	18.920	21.670	24.420	28.900	33.370	37.150	40.940
Evaporator pressure drop	kPa	27,2	24,2	30,5	23,2	29,6	25,0	25,0
ENERGY INDICES								
EER	W/W	2,32	2,33	2,29	2,32	2,34	2,30	2,28
ESSER	W/W	2,90	2,88	2,84	2,89	2,98	2,93	2,95
ELECTRICAL DATA								
Alimentazione	V	3N~400 V 50 HZ (versions 0275 - 0750), 3~400 V 50Hz (versions 0800 - 1000)						
Corrente assorbita totale	A	82,8	91,9	107,5	122,8	138,1	155,8	173,4
Corrente massima	A	131	143	164	190	225	245	277
Corrente di spunto	A	205	212	266	315	334	401	419
COMPRESSORS								
Type		scroll	scroll	scroll	scroll	scroll	scroll	scroll
Number	n°	4	4	4	4	4	4	4
Number per circuit	n°+n°+n°+n°	4/2	4/2	4/2	4/2	4/2	4/2	4/2
COMPRESSOR HEATER								
Compressor carter heater	n°xW	4 x 75	4 x 75	4 x 75	2x75 2x130	4 x 130	4 x 130	4 x 130
FANS								
Type		centrifugal	centrifugal	centrifugal	centrifugal	centrifugal	centrifugal	centrifugal
Number	n°	3	3	3	3	4	4	4
Input current ventilation unit	A	14,3	14,3	15,8	18,0	20,4	26,1	33,1
Input power ventilation unit	kW	8,1	8,1	9	10,2	11,6	14,8	18,8
Air flow rate	m3/h	31.500	31.500	35.000	35.000	42.000	47.600	47.600
EVAPORATORS								
Type		plate	plate	plate	plate	plate	plate	plate
Number	n°	1	1	1	1	1	1	1
HYDRAULIC CIRCUIT								
Water storage tank	lt	500	500	500	500	700	700	700
Storage tank anti-freeze heater	W	300	300	300	2x300	2x300	3x300	2x300
LOW PRESSURE PUMPING UNIT								
Input power	kW	1,1	1,5	1,85	1,85	3	3	3
Input current	A	2,14	2,92	3,6	3,6	6,2	6,2	6,2
Useful pressure pumping	kPa	82	93	117	118	120	116	102
HIGH PRESSURE PUMPING UNIT								
Input power	kW	3,7	3,7	3,7	3,7	5,5	5,5	5,5
Input current	A	7,21	7,21	7,21	7,21	11	11	11
Useful pressure pumping	kPa	183	168	154	164	210	207	185
SOUND DATA								
Sound Power	dB(A)	86	86	87	87	88	88,5	88,5
Sound pressure (1)	dB(A)	54,0	54,0	55,0	55,0	56,0	56,5	56,5
DIMENSIONS VERSIONS STANDARD (without storage tank and pump)								
Height	mm	2288	2288	2288	2288	2295	2295	2295
Width	mm	3750	3750	4550	4550	4950	4950	4950
Length	mm	1100	1100	1100	1100	1300	1300	1300
EMPTY WEIGHT versions without storage tank and pumps								
	kg	1481	1498	1737	1918	2670	2700	2960

NOTE: for the plumbing connections, refer to the installation manual.

5.4 TECHNICAL DATA HEAT PUMP VERSIONS (H)

NRC H		0275	0300	0325	0350	0500	0550
Cooling capacity:	kW	49	57	65	74	86	94
Total input power	kW	21,6	25,6	28,8	31,7	36,9	39,6
Evaporator water flow rate	l/h	8.430	9.800	11.180	12.730	14.790	16.170
Evaporator pressure drop	kPa	34,2	30,3	32,5	42,2	25,4	20,7
ENERGY INDICES							
EER	W/W	2,27	2,23	2,26	2,33	2,33	2,37
COP	W/W	2,32	2,27	2,33	2,40	2,38	2,43
ESEER		2,54	2,49	2,53	2,61	2,7	2,75
HOT MODE							
Heating capacity	kW	58	67	77	87	101	111
Total input power	kW	25,0	29,5	33,0	36,2	42,5	45,7
Evaporator water flow rate	l/h	9.980	11.520	13.248	14.960	17.370	19.090
Evaporator pressure drop	kPa	42,0	36,8	40,9	51,7	32,2	26,5
ELECTRICAL DATA							
Fuel feed	V	3N~400 V 50 HZ (versions 0275 - 0750), 3~400 V 50Hz (versions 0800 - 1000)					
Total input current only cooling	A	39,7	45,8	50,5	56,7	67,1	71,0
Total absorbed current HEATING	A	44,0	50,7	56,1	62,7	74,4	78,9
Maximum current	A	54	63	71	80	93	99
Peak current	A	155	162	168	210	222	227
COMPRESSORS							
Type		scroll	scroll	scroll	scroll	scroll	scroll
Number	n°	2	2	2	2	3	3
Number per circuit	n°+n°+n°+n°	2/2	2/2	2/2	2/2	3/2	3/2
COMPRESSOR HEATER							
Compressor carter heater	n°xW	2x75	2x75	2x75	2x75	3x75	3x75
FANS							
Type		centrifugal	centrifugal	centrifugal	centrifugal	centrifugal	centrifugal
Number	n°	2	2	2	2	2	2
Input current ventilation unit	A	4,5	7,8	8,5	5,8	7,3	7,3
Input power ventilation unit	kW	2,7	4,6	5,0	3,4	4,3	4,3
Air flow rate	m ³ /h	16.000	22.000	22.000	26.000	27.000	27.000
EVAPORATORS							
Type		plate	plate	plate	plate	plate	plate
Number	n°	1	1	1	1	1	1
HYDRAULIC CIRCUIT							
Water storage tank	lt	500	500	500	500	500	500
Storage tank anti-freeze heater	W	300	300	300	300	300	300
LOW PRESSURE PUMPING UNIT							
Input power	kW	0,75	0,75	0,75	0,75	1,1	1,1
Input current	A	1,85	1,85	1,85	1,85	2,14	2,14
Useful pressure pumping	kPa	137	134	126	108	146	132
HIGH PRESSURE PUMPING UNIT							
Input power	kW	1,10	1,10	1,50	1,50	1,85	1,85
Input current	A	2,14	2,14	2,92	2,92	3,60	3,60
Useful pressure pumping	kPa	180	176	170	157	196	196
SOUND DATA							
Sound Power	dB(A)	84,9	84,9	85,6	88,4	88,2	88,3
Sound pressure [1]	dB(A)	53	53	54	56	56	56
DIMENSIONS VERSIONS STANDARD (without storage tank and pump)							
Height	mm	1763	1793	1793	1763	1963	1963
Width	mm	2100	2100	2100	2450	2450	2450
Length	mm	950	950	950	950	950	950
EMPTY WEIGHT versions without storage tank and pumps							
	kg	689	737	748	841	983	999

NOTE: for the plumbing connections, refer to the installation manual.

NRC H		0600	0650	0700	0750	0800	0900	1000
Cooling capacity:	kW	118	134	152	178	204	230	254
Total input power	kW	51,0	56,5	64,0	76,0	89,5	100,0	112,0
Evaporator water flow rate	l/h	20.300	23.050	26.140	30.620	35.090	39.560	43.690
Evaporator pressure drop	kPa	30,5	27,0	34,8	26,0	32,8	28,0	28,3
ENERGY INDICES								
EER	W/W	2,31	2,37	2,38	2,34	2,28	2,30	2,27
COP	W/W	2,37	2,44	2,45	2,48	2,48	2,47	2,47
ESEER		3,1	3,09	3,09	3,05	3,06	3,08	3,04
HOT MODE								
Heating capacity	kW	136	155	175	207	239	267	295
Total input power	kW	57,5	63,5	71,5	83,5	96,5	108,0	119,5
Evaporator water flow rate	l/h	23.390	26.660	30.100	35.600	41.110	45.920	50.740
Evaporator pressure drop	kPa	39,9	40,0	41,0	31,0	45,2	42,2	44,9
ELECTRICAL DATA								
Fuel feed	V	3N~400 V 50 HZ (versions 0275 - 0750), 3~400 V 50Hz (versions 0800 - 1000)						
Total input current only cooling	A	92,0	99,8	115,3	133,5	153,7	172,7	192,9
Total absorbed current HEATING	A	101,9	110,9	127,4	145,8	166,2	186,5	206,9
Maximum current	A	131	143	164	190	225	245	277
Peak current	A	213	223	275	326	346	414	435
COMPRESSORS								
Type		scroll	scroll	scroll	scroll	scroll	scroll	scroll
Number	n°	4	4	4	4	4	4	4
Number per circuit	n°+n°+n°+n°	4/2	4/2	4/2	4/2	4/2	4/2	4/2
COMPRESSOR HEATER								
Compressor carter heater	W	4x75	4x75	4x75	2x75 2x130	4x130	4x130	4x130
FANS								
Type		centrifugal	centrifugal	centrifugal	centrifugal	centrifugal	centrifugal	centrifugal
Number	n°	3	3	3	3	4	4	4
Input current ventilation unit	A	17,4	17,4	18,6	21,9	27,2	32	38
Input power ventilation unit	kW	9,9	9,9	10,5	12,45	15,4	18	21,6
Air flow rate	m3/h	45.000	45.000	50.000	50.000	60.000	68.000	68.000
EVAPORATORS								
Type		plate	plate	plate	plate	plate	plate	plate
Number	n°	1	1	1	1	1	1	1
HYDRAULIC CIRCUIT								
Water storage tank	lt	500	500	500	500	700	700	700
Storage tank anti-freeze heater	n°xW	300	300	300	2x300	2x300	2x300	2x300
LOW PRESSURE PUMPING UNIT								
Input power	kW	3,7	3,7	3,7	3,7	3	3	3
Input current	A	7,21	7,21	7,21	7,21	6,22	6,22	6,22
Useful pressure pumping	kPa	60	100	117	116	105	102	88
HIGH PRESSURE PUMPING UNIT								
Input power	kW	3,7	3,7	3,7	3,7	5,5	5,5	5,5
Input current	A	7,21	7,21	7,21	7,21	11	11	11
Useful pressure pumping	kPa	177	160	142	162	225	222	204
SOUND DATA								
Sound Power	dB(A)	90	90	91	91	92	92,5	92,5
Sound pressure (1)	dB(A)	58	58	59	59	60	60	60
DIMENSIONS VERSIONS STANDARD (without storage tank and pump)								
Height	mm	2288	2288	2288	2288	2295	2295	2295
Width	mm	3750	3750	4550	4550	4950	4950	4950
Length	mm	1100	1100	1100	1100	1300	1300	1300
EMPTY WEIGHT versions without storage tank and pumps								
	kg	1593	1610	1831	2001	2797	2827	3095

NOTE: for the plumbing connections, refer to the installation manual.

6 SELECTION CRITERIA

The devices in their standard configurations are not suitable for installation in salty environments. The maximum and minimum limits for the water flow rate to the exchanger are indicated by the curves of the pressure drop diagrams. For the operating limits, refer to the diagrams

below, valid for $\Delta t = 5^\circ\text{C}$.

WARNING:

- operation with a processed water temperature of less than 4°C is only allowed for the versions specifically designed for this [version Y].
- if you want to operate the machine

outside the limits indicated in the diagram, please contact the AERMEC technical/commercial office.

6.1 OPERATING LIMITS

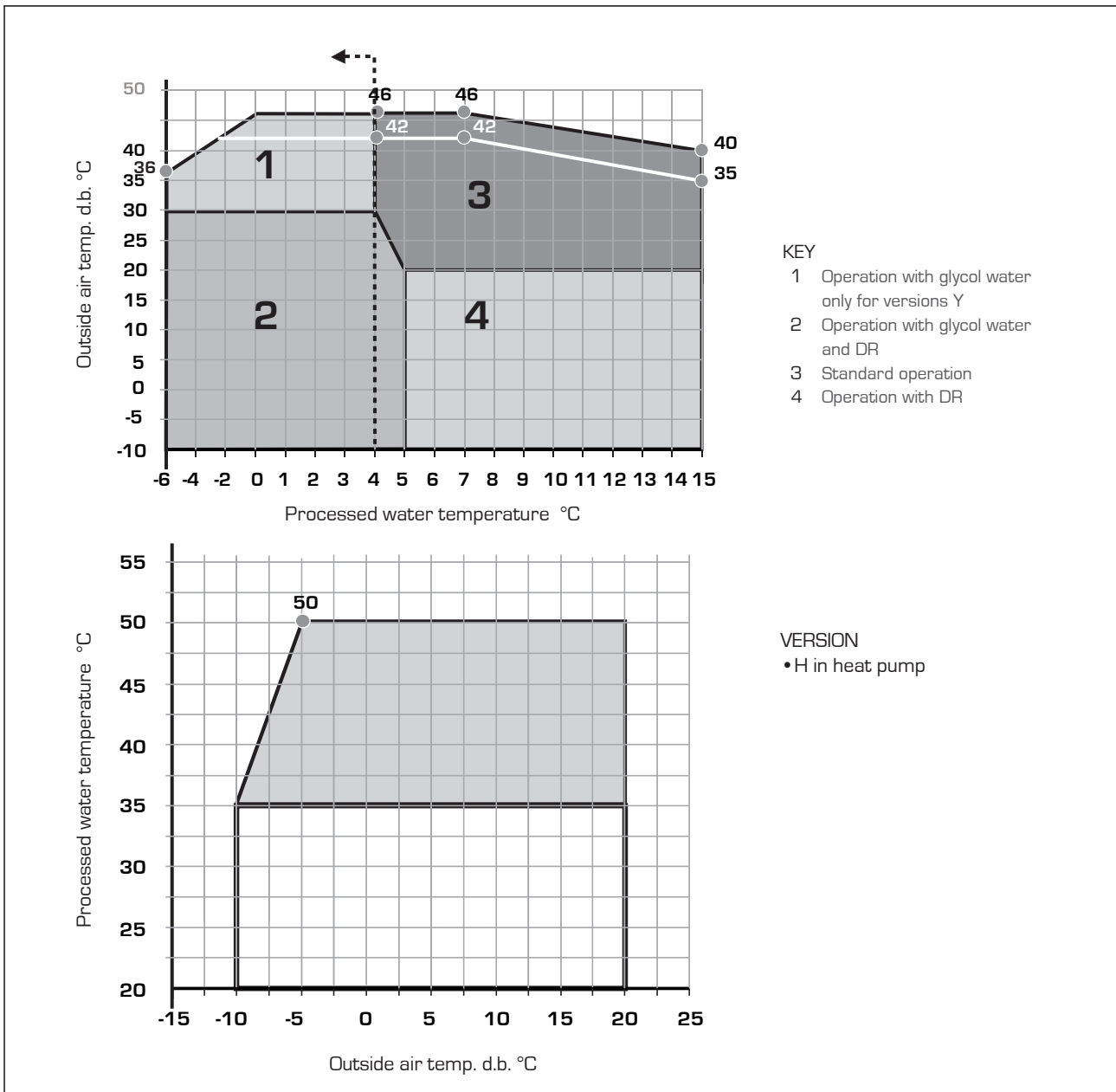

6.2 PROJECT DATA

(1) = only for heat pump versions

		High pressure side	Low pressure side
Maximum pressure allowed	bar	30 / 28 (1)	22
Maximum temperature allowed	$^\circ\text{C}$	120	52
Minimum temperature allowed	$^\circ\text{C}$	-10	-16 / -10 (1)

7 CORRECTION COEFFICIENTS

7.1 COOLING AND INPUT CAPACITIES

- "STANDARD VERSIONS"
- "HEAT PUMP VERSIONS IN COLD MODE"

The refrigerating capacity yielded and the input electrical capacity in conditions other than rated conditions are obtained by multiplying the rated values (Pf, Pa) by the respective correction coefficients (Cf, Cpa).

The following diagrams allow you to obtain the correction coefficients to be used for the various versions of the devices, in cold mode; next to each curve you can see the outside air temperature to which it refers.

KEY:

Cf = Cooling capacity correction coefficient

Ca = Input power correction coefficient

FOR VERSIONS Y with temperatures lower than 4°C, contact the company headquarters

FOR ΔT OTHER THAN 5°C

For the evaporator, the Tav.7.4 is used to obtain the correction factors of the cooling and input capacities. To take into account the dirtying of the exchangers, the relative dirtying factors are used

7.2 COOLING AND INPUT CAPACITIES

- "SILENCED VERSIONS"

The cooling capacity yielded and the electrical input power in conditions other than rated conditions are obtained by multiplying the rated values (Pf, Pa) by the respective correction coefficients (Cf, Ca).

The following diagrams allow you to obtain the correction coefficients to be used for the various versions of the devices, in cold mode; next to each curve you can see the outside air temperature to which it refers.

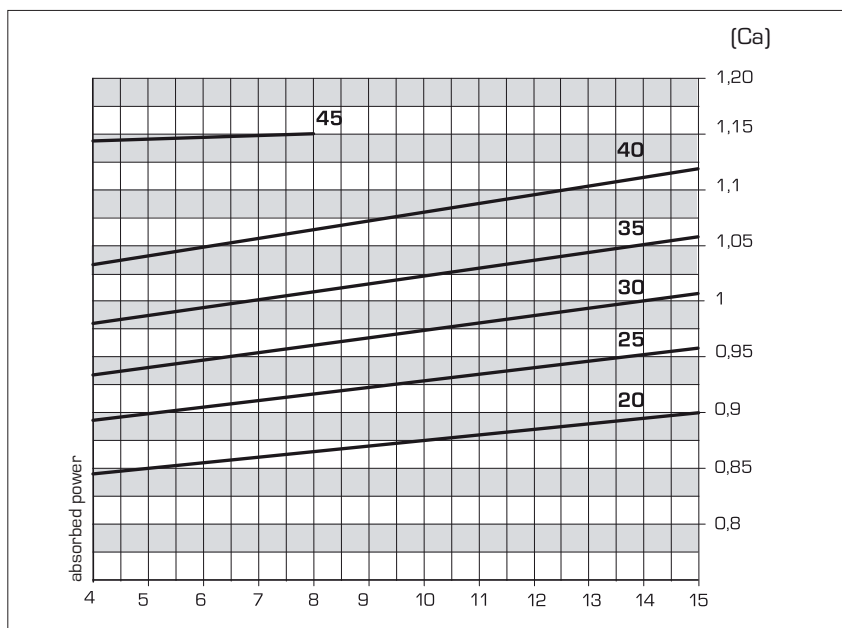
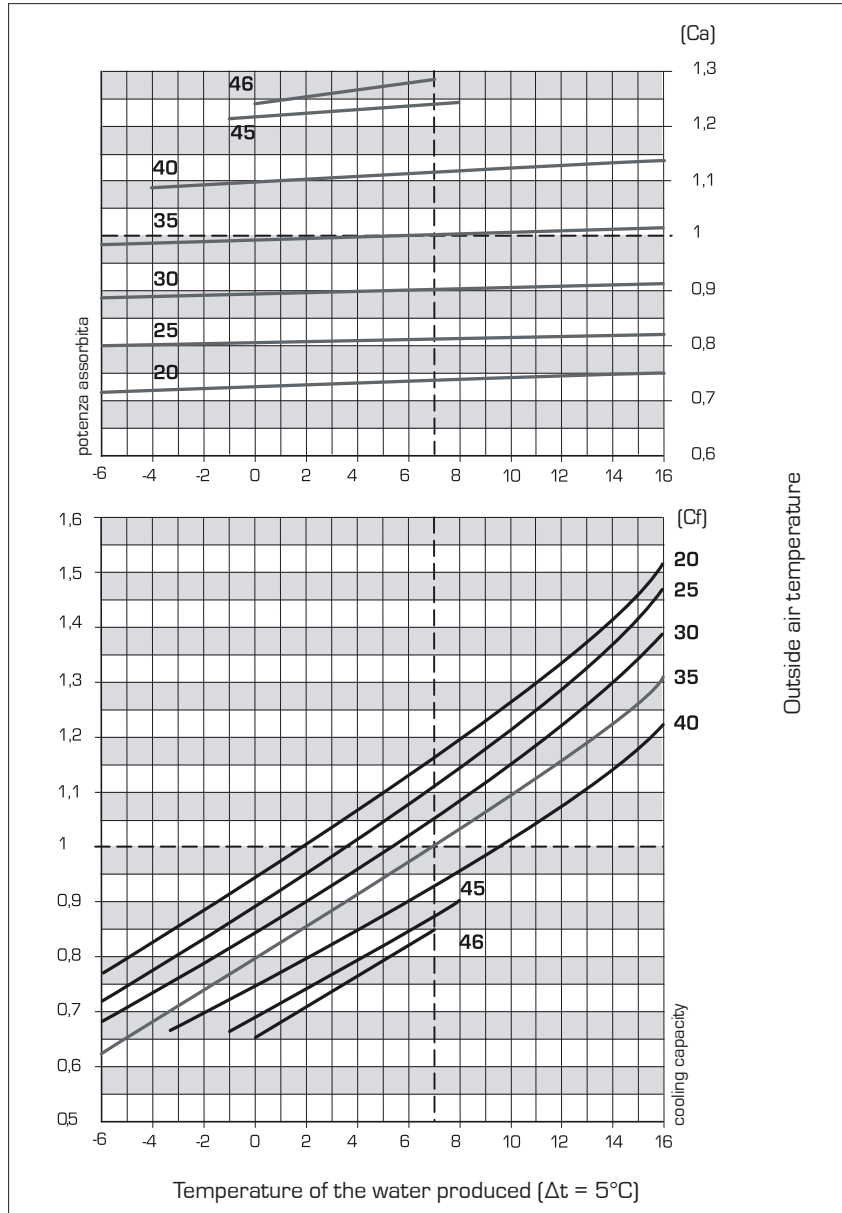

KEY:

Cf = Cooling capacity correction coefficient

Ca = Input power correction coefficient

- FOR THE VERSIONS Y with temperatures below 4°C contact company headquarters

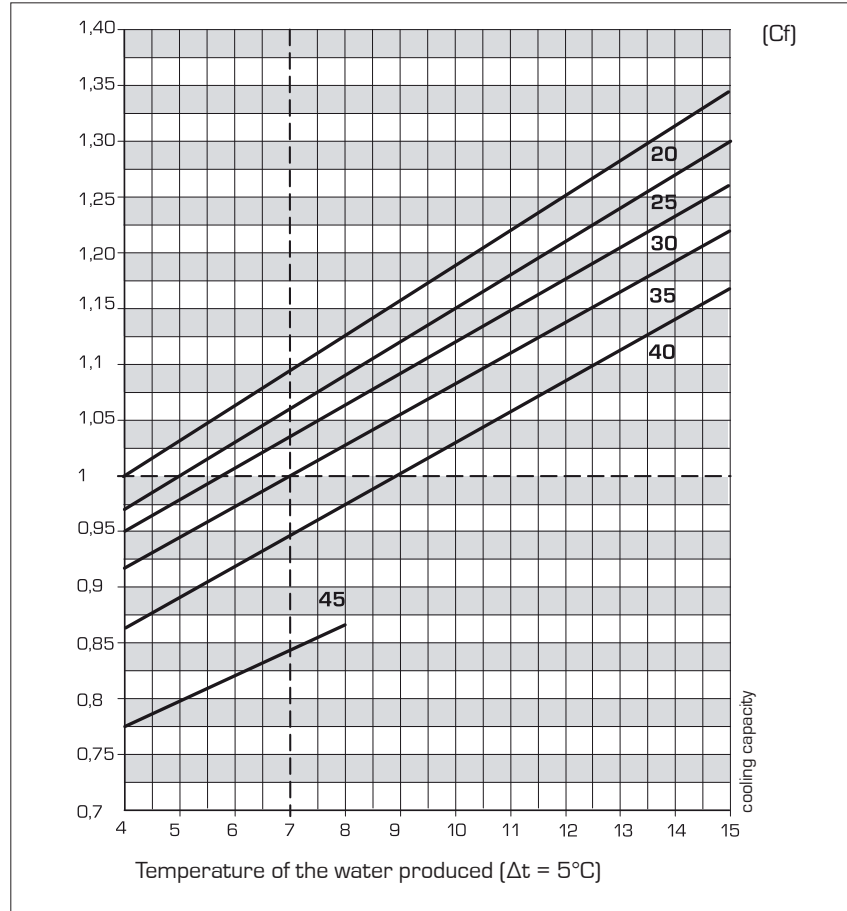

7.3 HEATING AND INPUT CAPACITIES

- "HEAT PUMP VERSIONS"

The heating capacity yielded and the electrical input power in conditions other than rated conditions are obtained by multiplying the rated values (Pf, Pa) by the respective correction coefficients (Cft, Cpa).

The following diagram makes it possible to obtain the correction coefficients; next to each curve, you can see the temperature of the hot processed water to which it refers, assuming a difference of water temperature between the inlet and outlet of the condenser equal to 5°C.

The yields are intended as net of the defrosting cycles.

KEY:

Ct = Heating capacity correction coefficient

Ca = Input power correction coefficient

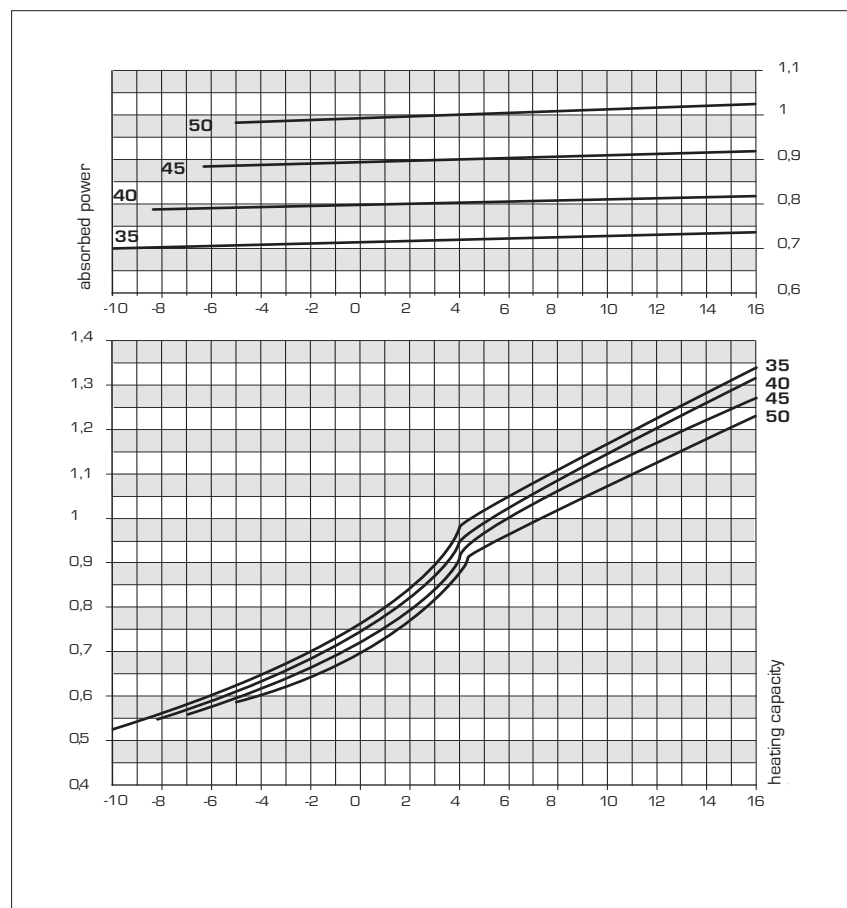

7.4 FOR ΔT OTHER THAN NOMINAL

For Δt other than 5°C, the $T_{av,1}$ is used on the evaporator to obtain the correction factors of the cooling and input capacities. To take into account the dirtying of the exchangers, the relative dirtying factors are used

7.5 FOULING FACTORS

The performance shown by the table refers to conditions with clean tubes, with a fouling factor = 1. For other fouling factor values, multiply the data of the performance tables by the coefficients given.

7.4.1 Correction factors for Δt other than nominal, Chiller

	3	5	8	10
Cooling capacity correction factors	0,99	1	1,02	1,03
Input absorbed power correction factors	0,99	1	1,01	1,02

7.5.1 Fouling factors

	[K*m²]/[W]	0,00005	0,0001	0,0002
Cooling capacity correction factors		1	0,98	0,94
Input absorbed power correction factors		1	0,98	0,95

8 ETHYLENE GLYCOL SOLUTION

The cooling capacity and input power correction factors make allowance for the presence of glycol and the different evaporation temperature.

The correction factors of the water flow rate and the pressure drops are applied directly to the data obtained for operation without glycols. The correction factor of the water flow rate is calculated so as to maintain the same Δt that would be used in the absence of glycols.

- The correction factor of the pressure drop already takes into account the different capacity deriving from the application of the water flow rate correction factor.
- The correction factors of the water flow rate and the pressure drops are applied directly to the data obtained for operation without glycols.
- The correction factors of the cooling and input capacities take into account the presence of glycols.

- The correction factors of the water flow rate and the pressure drops are applied directly to the data obtained for operation without glycols.
- The correction factor of the water flow rate is calculated so as to maintain the same Δt that would be used in the absence of glycols.
- The correction factor of the pressure drop already takes into account the different capacity deriving from the application of the water flow rate correction factor.

NOTE

To make it easier to read the graph, an example is given on the next page.

By using the diagram opposite it possible to establish the percentage of glycol necessary; this percentage can be calculated taking into account one of the following factors:
On the basis of the fluid considered (water or air), it will be necessary to enter the graph from the right or left side, from the intersection of the

outside air temperature or processed water temperature straight lines and the relative curves, a point is obtained through which the vertical line that will identify both the percentage of glycol and the relative correction coefficients will have to pass.

8.1 HOW TO READ THE GLYCOL CURVES

The curves shown in the figure summarise a notable quantity of data, each of which is represented by a specific curve. In order to use these curves correctly, it is necessary to make some initial considerations:

- If you want to calculate the percentage of glycol on the basis of the outside air temperature, you must enter from the left-hand axis and, once you have intersected the curve, trace a vertical line which, in turn, will intercept all the other curves; the points obtained from the upper curves represent

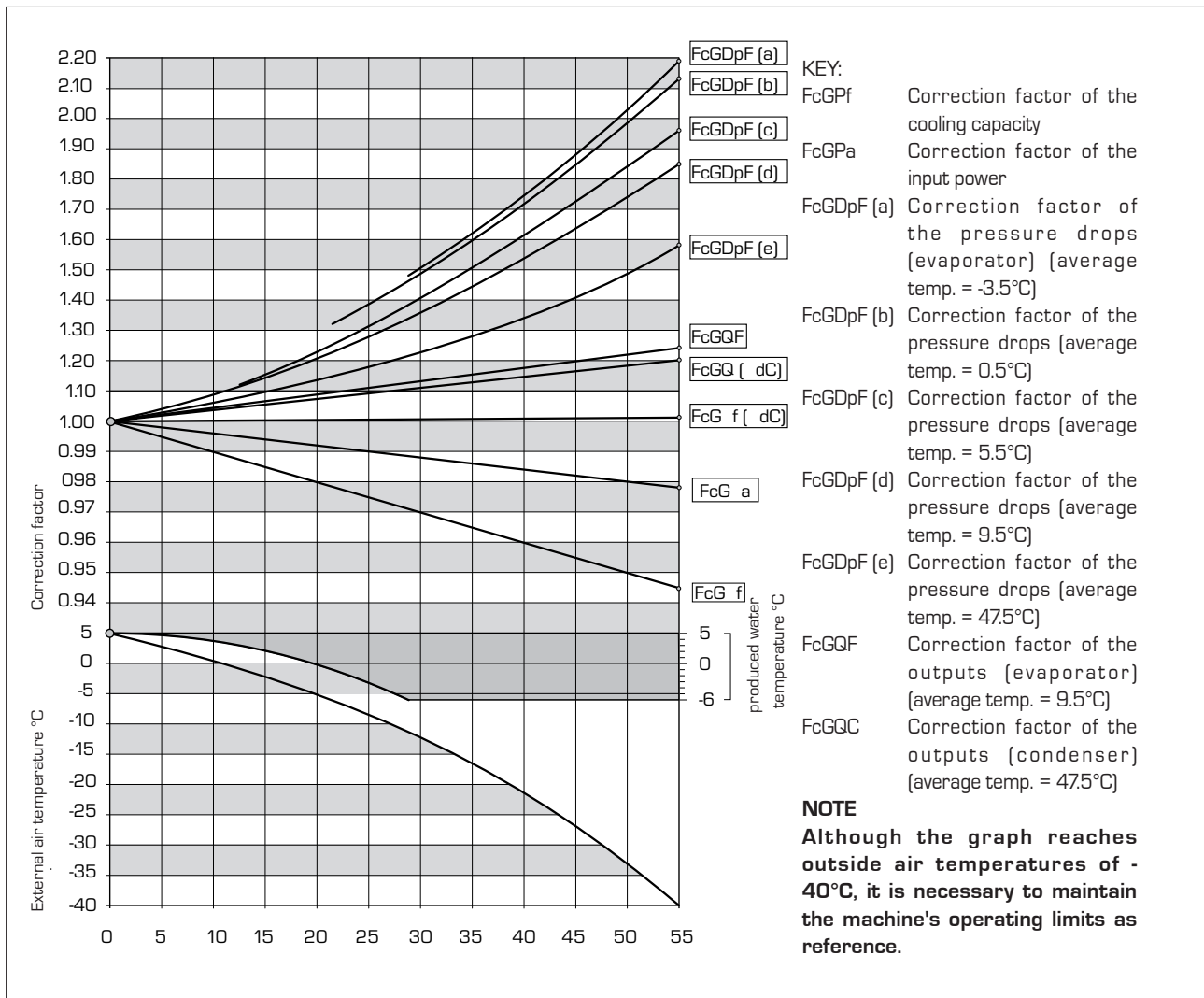

the coefficients for the correction of the cooling capacity and input power, for the flow rates and the pressure drops (remember that these coefficients must anyway be multiplied by the nominal value of the sizes examined); the lower axis advises the percentage of glycol necessary on the basis of the outside air temperature considered.

- If you want to calculate the percentage of glycol on the basis of the temperature of the

processed water, you must enter from the right-hand axis and, once you have intersected the curve, trace a vertical line which, in turn, will intercept all the other curves; the points obtained from the upper curves represent the coefficients for the cooling capacity and input power, for the flow rates and the pressure drops (remember that these coefficients must anyway be multiplied by the nominal value of the sizes examined); the lower axis

advises the percentage of glycol necessary to produce water at the required temperature.

Remember that the initial sizes "OUTSIDE AIR TEMPERATURE" and "PROCESSED WATER TEMPERATURE", are not directly linked to each other, so it is not possible to enter the curve of one of these sizes, and obtain the corresponding point on the other curve.

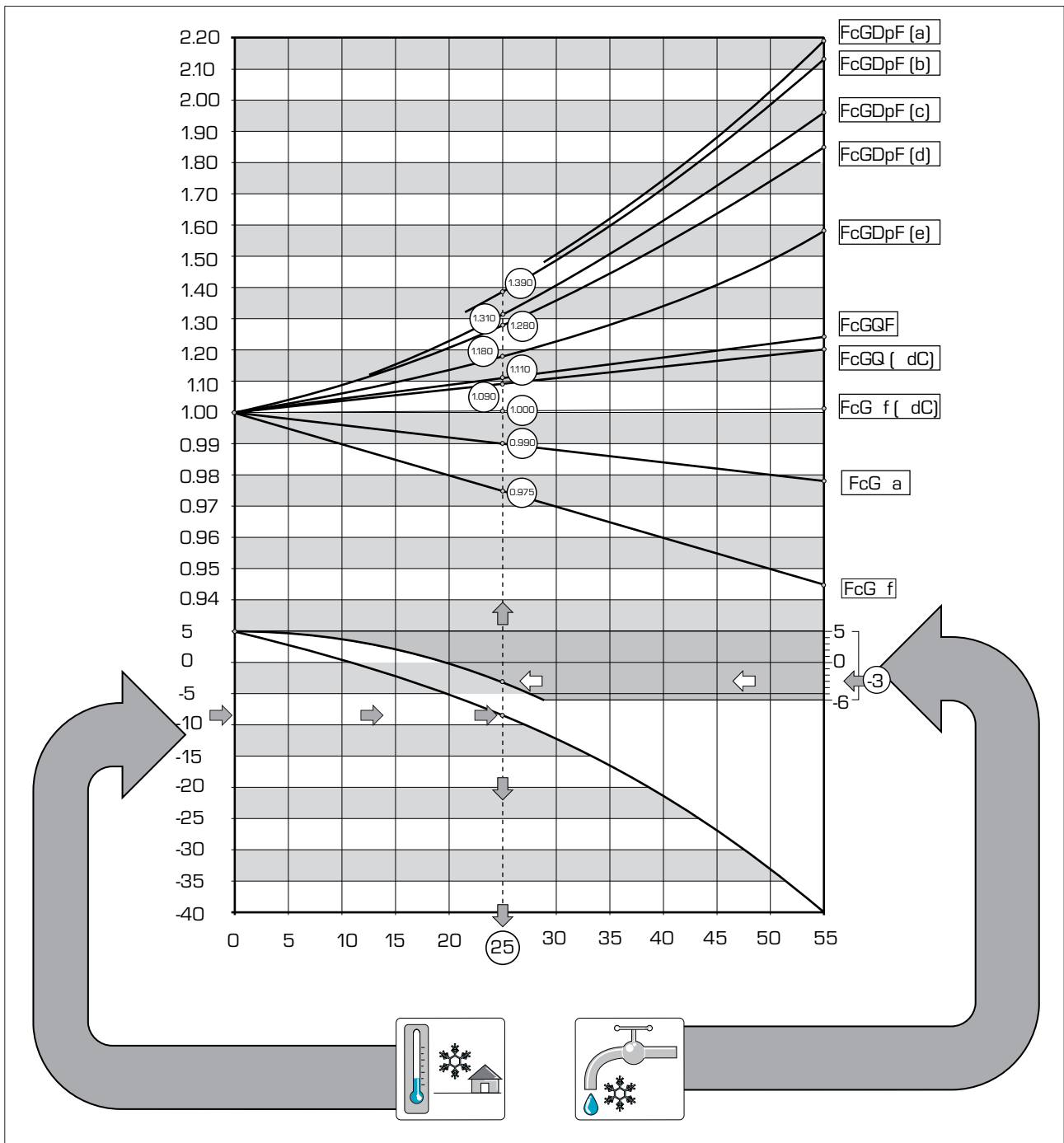

9 PRESSURE DROPS

9.1 PRESSURE DROPS, EVAPORATOR

The following diagrams show the values of the pressure drops in kPa, on the basis of the capacity in m³/h.

The operation field is defined by the minimum and maximum values of the curves, which indicate the limit of use of the water side heat exchangers (evaporators). The pressure drops of the diagrams

are relative to the average water temperature 10°C. The following table shows the correction to apply to the pressure drop when the average water temperature varies.

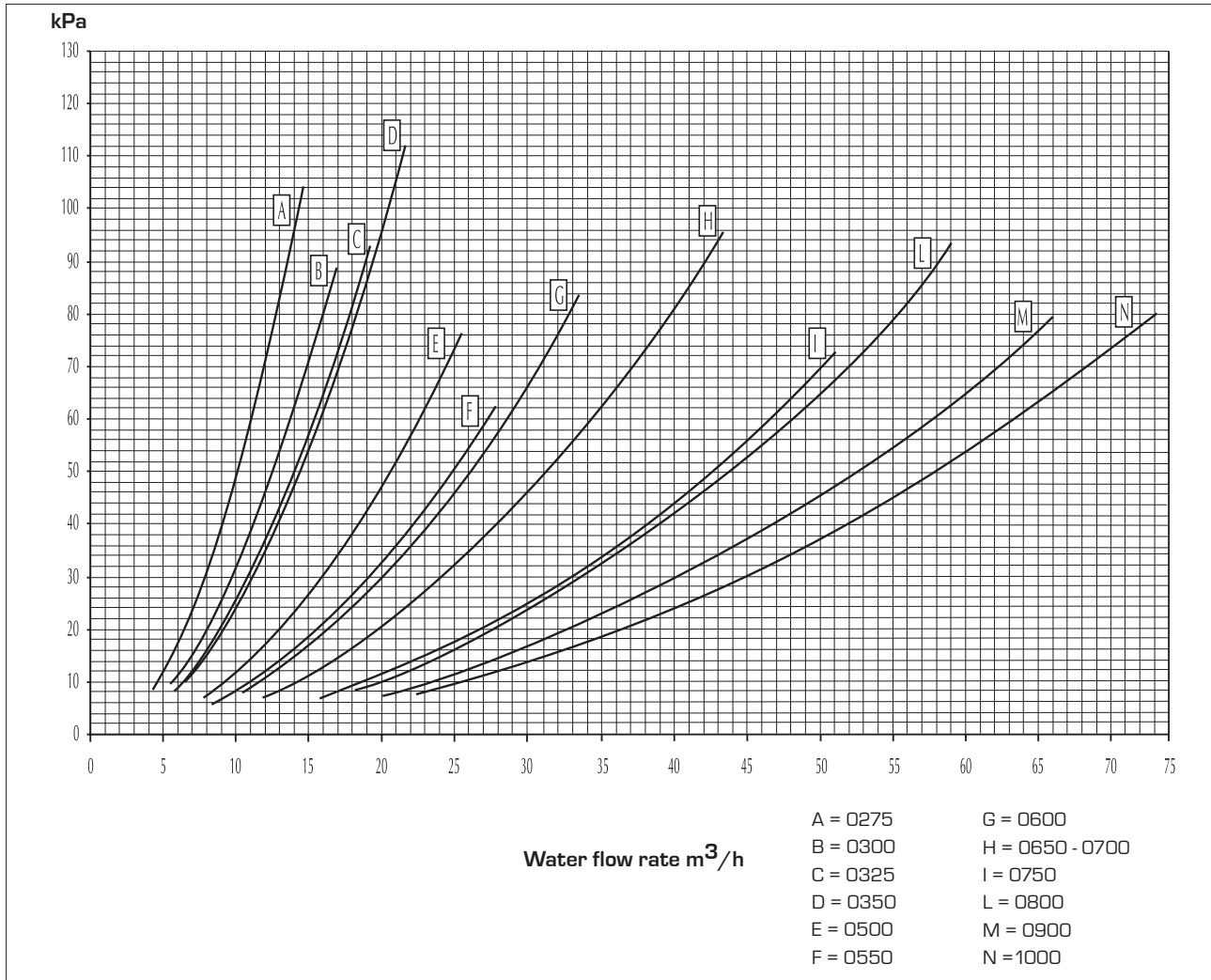

9.1.1 COEFFICIENT FOR DATA OTHER THAN NOMINAL

Average water temperature °C	5°C	10°C	15°C	20°C	30°C	40°C	50°C
Multiplicative coefficient	1,02	1	0,985	0,97	0,95	0,93	0,91

For temperature values differing from the nominal ones, refer to table 9.1.1 to obtain the coefficients.

9.2 PRESSURE DROPS, WATER FILTER

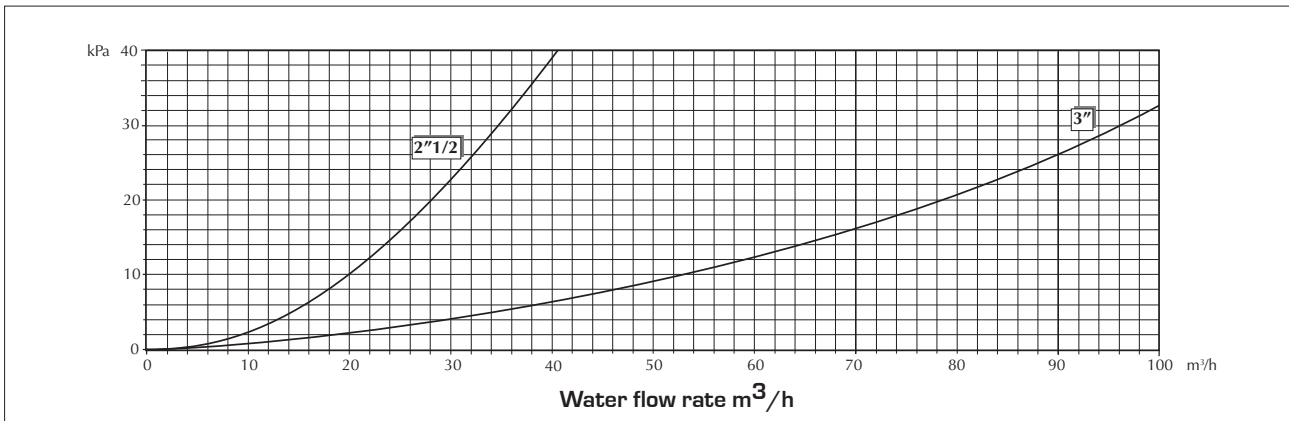

9.3 FILTER CHARACTERISTICS

MODELS	CHARACTERISTICS
0275 - 0300 - 0325 - 0350 - 0500 - 0550 - 0600 0650 - 0700 - 0750	<p>Ø gas : 2" 1/2 Ø hole inscribed: 600 micron number of holes per sq.cm: 53</p>
0275 - 0300 - 0325 - 0350 - 0500 - 0550 - 0600 0650 - 0700 - 0750	<p>with partial recovery desuperheater Filter on the circuit of the desuperheater: Ø gas: 1" 1/2 Ø hole inscribed: 500 micron number of holes per sq.cm: 80</p> <p>Hydraulic circuit filter: Ø gas: 2" 1/2 Ø hole inscribed: 600 micron number of holes per sq.cm: 53</p>
0275 - 0300 - 0325 - 0350 - 0500 - 0550 - 0600 0650 - 0700 - 0750	<p>with total recovery desuperheater Filter on the total recovery: Ø gas: 2" 1/2 Ø foro inscritto: 600 micron numero fori per cmq: 53</p> <p>Filtro circuito idraulico: Ø gas: 2" 1/2 Ø hole inscribed: 600 micron number of holes per sq.cm: 53</p>
0800 - 0900 - 1000	<p>Ø nominal: 80 mm Ø hole inscribed: 1600 micron number of holes per sq.cm: 22</p>
0800 - 0900 - 1000	<p>with total recovery desuperheater Total recovery filter Ø nominal: 80 mm Ø hole inscribed: 1600 micron number of holes per sq.cm: 22</p> <p>Hydraulic circuit filter Ø nominal: 80 mm Ø hole inscribed: 1600 micron number of holes per sq.cm: 22</p>

10 STORAGE TANK

The versions with storage tank offer different set-ups that vary on the basis of the effective pressure that you want to obtain, the characteristics of the pumping unit, and the presence or absence of holes for integrative resistance.

The following tables show the main characteristics of the components of the hydraulic circuit, while the graphs on these pages show the relative pressures.

The storage tank tanks with holes for heaters are equipped with plastic, temporary closing plugs.

WARNING

Before start-up, the installer must assemble the heaters. If these heaters are not immediately necessary, the plastic plugs must be replaced with suitable metal plugs.

10.1 MAXIMUM WATER CONTENT IN THE SYSTEM

The table to the side indicates the maximum water content, in litres, of the hydraulic system, compatible with the capacity of the expansion tank supplied as standard. The values shown in the table refer to three conditions of maximum and minimum water temperature. If the effective water content of the hydraulic system (including the storage tank tank) is greater than that shown in the operational conditions table, another, additional expansion tank must be installed, measured (using the common criteria) with reference to the additional volume of water. From the following tables, it is possible to obtain the values of maximum system content, also for other operational conditions with glycol water. The values are obtained by multiplying the reference value by the correction coefficient.

10.1.1 Calibration of expansion tank

The standard value of pre-charge pressure of the two expansion tanks is 1.5 bar, while their volume is 24 litres, **maximum value 6 bar.**

The calibration of the tanks must be regulated on the basis of the maximum difference of level (H) of the user (see figure), according to the formula:

$$p \text{ [calibration] [bar]} = H \text{ [m]} / 10.2 + 0.3$$

For example, if the level difference H is 20m, the calibration value of the tank

Hydraulic height	H m	30	25	20	15	10
Calibration of expansion tank	bar	3,2	2,8	2,3	1,8	standard
Water content reference value	l (1)	1087	1323	1559	1795	1926
Water content reference value	l (2)	489	595	702	808	866
Water content reference value	l (3)	255	311	366	422	452

Glycol water	Water temp. °C		Correction coefficient	Reference condition
	max.	min.		
10%	40	-2	0,507	(1)
10%	60	-2	0,686	(2)
10%	85	-2	0,809	(3)
20%	40	-6	0,434	(1)
20%	60	-6	0,604	(2)
20%	85	-6	0,729	(3)
35%	40	-6	0,393	(1)
35%	60	-6	0,555	(2)
35%	85	-6	0,677	(3)

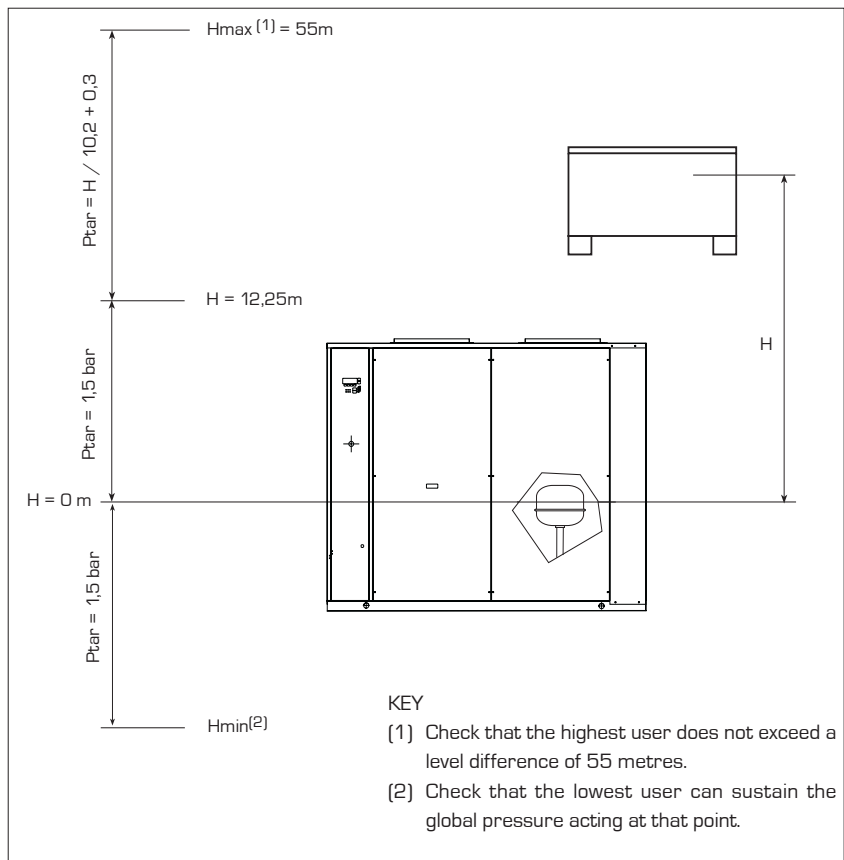

will be 2.3 bar.

If the calibration value obtained from the calculation is lower than 1.5 bar (i.e. for $H < 12,25$), maintain the standard calibration.

11 EFFECTIVE PRESSURE FOR THE SYSTEM

The pressures shown here are net of the pressure drops of the heat exchangers, filter, etc. They should therefore be considered useful for the system.

WARNING

As in the configurator, the pumps can be high or low pressure, so we will give two distinct diagrams to avoid confusion in the selection.

11.1 LOW PRESSURE PUMPS

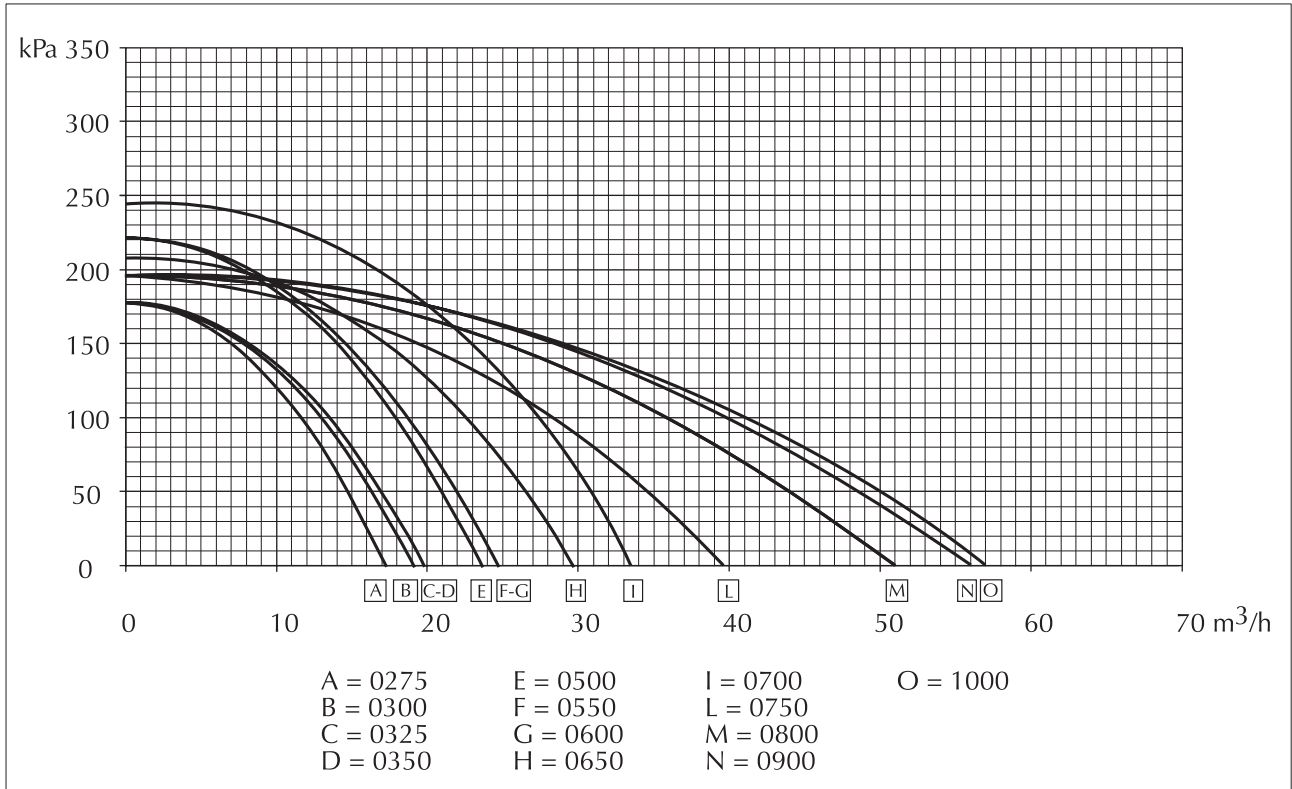

11.2 HIGH PRESSURE PUMPS

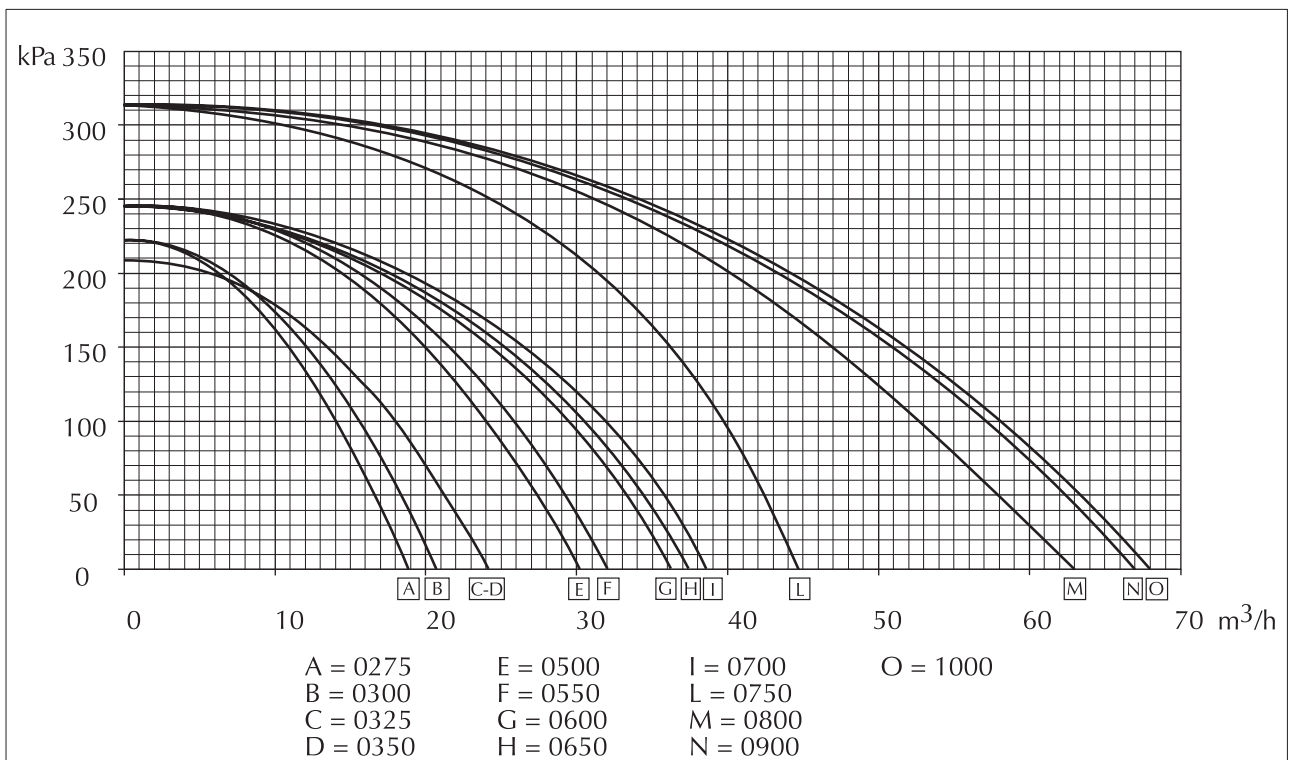

12 DESUPERHEATERS

The heating capacity that can be obtained from the desuperheater is calculated by multiplying the rated value (Pd), indicated in the table below the diagrams, by a suitable coefficient (Cd). The diagrams allow the correction coefficients to be used for the various versions of chiller to be calculated; the external air temperature referred to is indicated in correspondence with each curve. The pressure drops you see in the table do not include the filter drop, whose curve is indicated in table TAV 9.2.

The nominal value refers to:
 air temperature 35°C
 produced water temperature 50°C.

NOTE

in the models with heat pump the desuperheater must be intercepted when the heat pump is operating, otherwise the guarantee will not be valid.

12.1 STANDARD VERSION

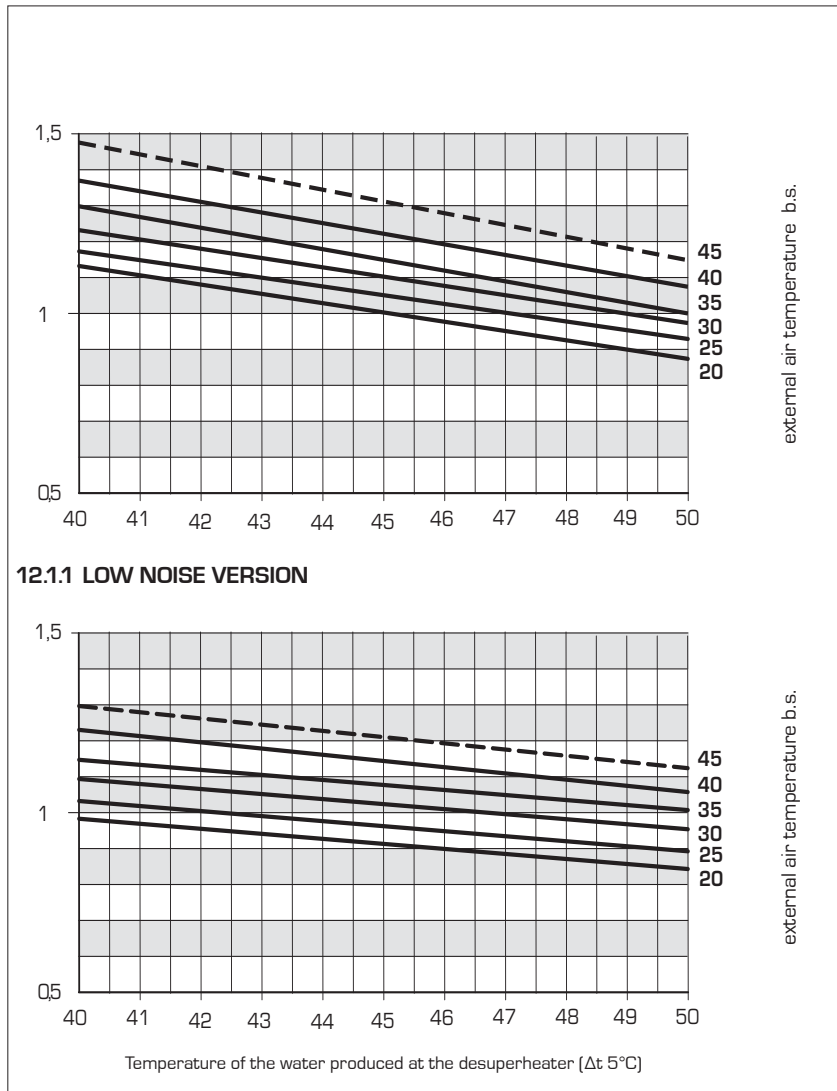

12.1.1 LOW NOISE VERSION

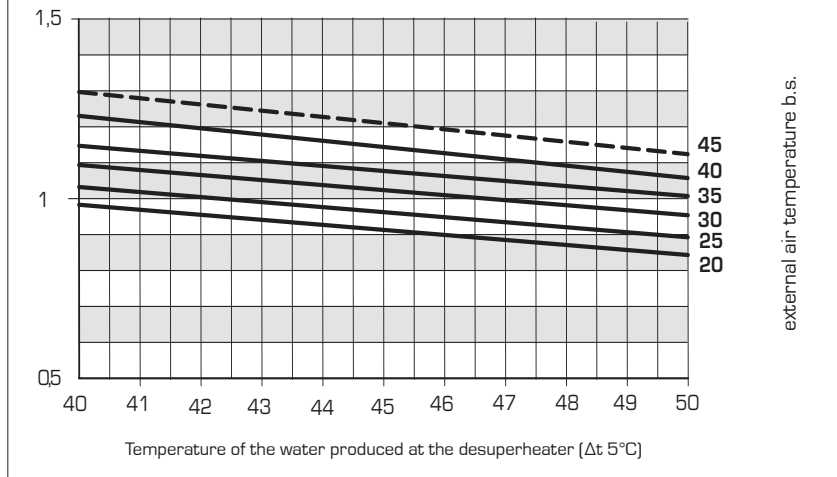

12.1.2 NOMINAL DATA STANDARD VERSION/LOW NOISE VERSION/HEAT PUMP VERSION

STANDARD VERSION													
Size	0275	0300	0325	0350	0500	0550	0600	0650	0700	0750	0800	0900	1000
Pd (Kw)	12,8	14,8	16,8	19,0	22,3	24,3	29,4	33,3	38,3	45,2	53,50	59,50	66
Qn (M3/h)	2,19	2,54	2,88	3,27	3,83	4,17	5,06	5,73	6,59	7,78	9,20	10,23	11,3
Δp (Kpa)	9,20	7,20	9,00	11,30	9,60	9,30	13,3	8,2	11,9	9,1	16	19,5	11,5

LOW NOISE VERSION / HEAT PUMP VERSIONS													
Size	0275	0300	0325	0350	0500	0550	0600	0650	0700	0750	0800	0900	1000
Pd (Kw)	11,5	13,5	15,5	17,5	20,3	22,3	27,8	31,7	36,0	42,6	48,5	54	59,5
Qn (M3/h)	1,98	2,32	2,67	3,01	3,48	3,83	4,78	5,44	6,19	7,32	8,34	9,3	10,2
Δp (Kpa)	8,30	6,60	8,30	10,40	8,70	8,50	11,70	7,2	10,4	7,9	-	-	-

Pd = The heating capacity available to the desuperheaters in nominal conditions :air temperature 35°C and processed water 50°C.

Qn = Water flow rate

Δp =Pressure drop

12.2 VALUES DIFFERENT FROM THE NOMINAL VALUE

For temperatures of produced water other than 50 °C, multiply the result by the correction factor that can be determined from the table.

Average water temperature °C	30	40	50
Multiplicative coefficient	1,04	1,02	1

For chilled water production at temperatures other than 7°C or for evaporation temperatures other than 5°C, use the correction factors in the table provided, as well as the ones obtained from the graphs.

Water temperature °C	5°C	7°C	9°C	11°C	13°C	15°C
Correction factor	0,94	1	1,07	1,13	1,2	1,27
Evaporation temperature	1°C	3°C	5°C	7°C	9°C	11°C
Correction factor	0,88	0,94	1	1,06	1,13	1,2

12.3 PRESSURE DROPS

All sizes of NRC models with desuperheater have 2 desuperheaters (arranged parallel to each other).

NOTE

the installer is responsible for the hydraulic parallel.

The characteristics of the desuperheaters and the pressure drop curves are shown below.

The heating capacity available to the desuperheaters is at the nominal conditions:

Air temperature	35 °C
Processed water	50 °C
Δt	5 °C

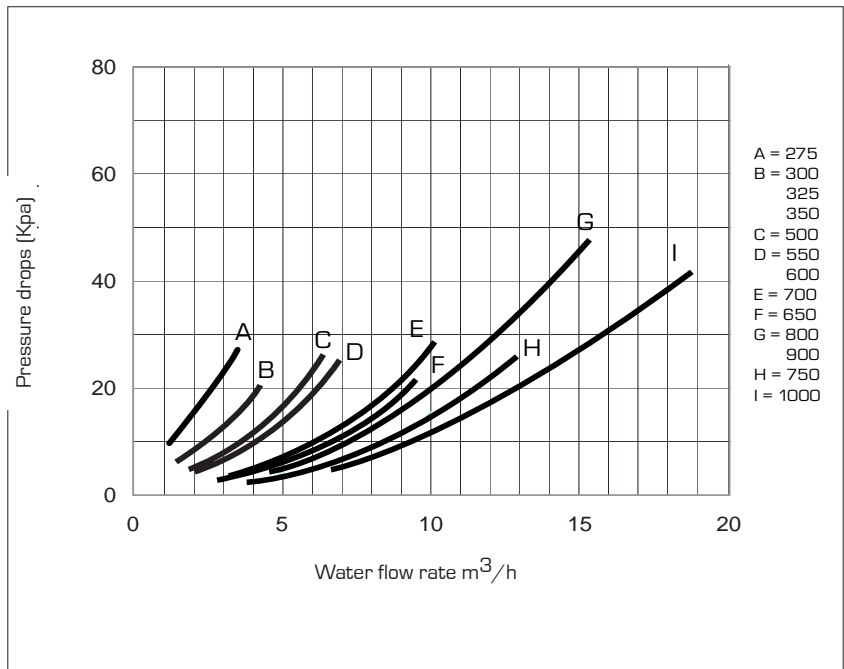

12.4 DESUPERHEATER FILTER PRESSURE DROPS

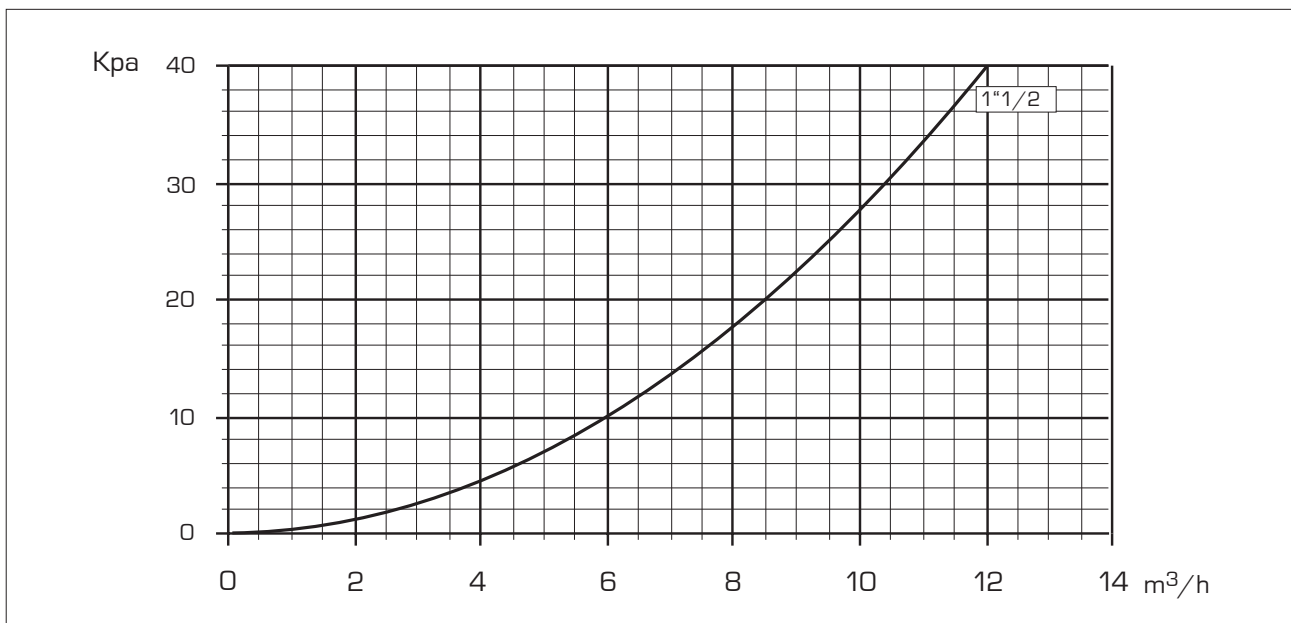

13 TOTAL RECOVERY

When operating with the total heat recovery function, machine performance depends on the temperature of the hot water produced, not on that of external air; to calculate the absorbed electrical and heat recovery power values, multiply the values (Pa, Pr) specified at the bottom of the page by the relevant correction factors [Ca, Cr] derived from the diagrams below. The temperature of the relative hot water is given for each curve (a difference of 5°C between total heat recovery unit input and output is presumed). Calculate the cooling power (Pf) by measuring the difference between heat recovery power (Pr) and power absorbed (Pa).

The heating capacity available to the desuperheaters is at the nominal conditions:

Air temperature	35 °C
Processed water	50 °C
Δt	5 °C

13.1 PRESSURE DROPS

All NRC models with total recovery are equipped with two recoveries in parallel. Heat recovery unit specifications and load loss curves are shown below. The pressure drops you see in the table do not include the filter drop, whose curve is indicated in page 23.

For temperatures of produced water other than 50 °C, multiply the result by the correction factor that can be determined from the table 13.1.1

The parallel water connections is to be made by the installer.

The pressure drops in the diagram refer to an average water temperature of 50°C. Table 13.1.1 shows the correction to be applied to the pressure drops when the average water temperature varies.

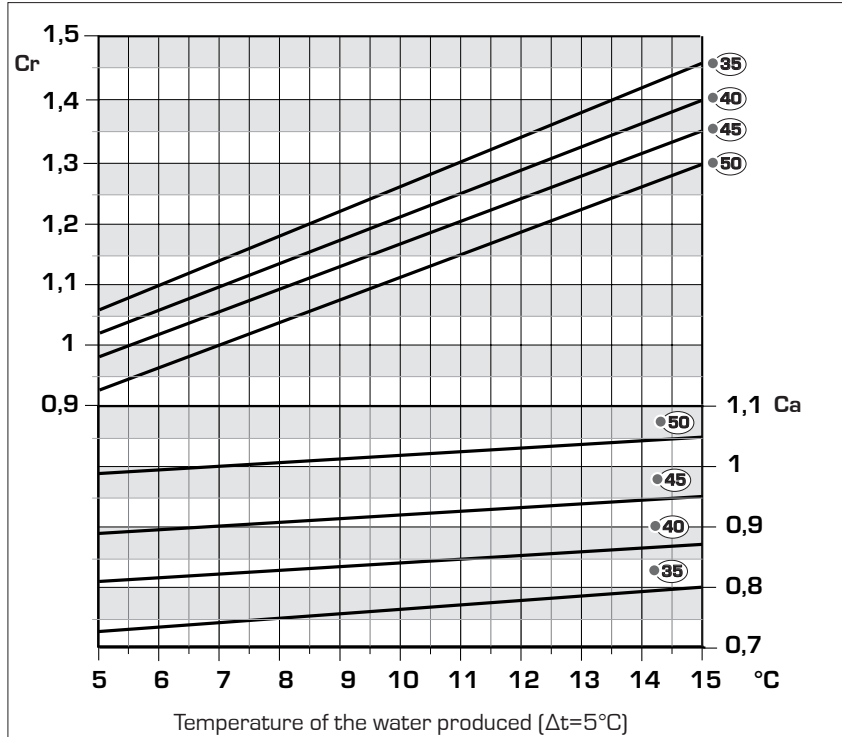

KEY

Cr = Recovered capacity correction coefficient

Ca = Input power correction coefficient

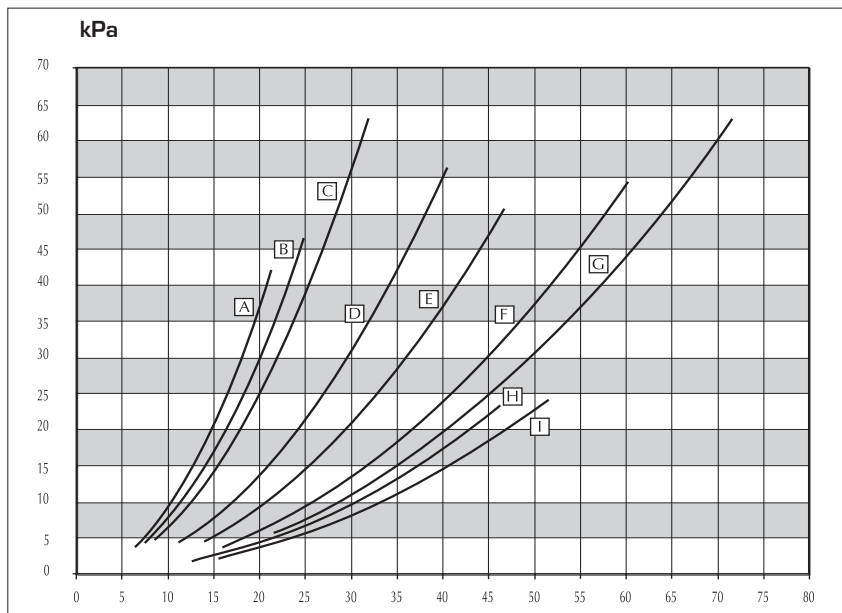

A =	0275	F =	0650 - 0700
B =	0300	G =	0750
C =	0325 - 0350	H =	0800 - 0900
D =	0500 - 0550	I =	1000
E =	0600		

13.1.1 VALUES DIFFERENT FROM THE NOMINAL VALUE

Average water temperature C°	30	40	50
Correction factor	1,04	1,02	1

13.1.2 PRESSURE DROPS

Size	0275	0300	0325	0350	0500	0550	0600	0650	0700	0750	0800	0900	1000
Pr (kW)	70,0	80,5	91,0	104,0	122,0	133,0	162,9	184,9	210,6	250,1	291,7	322,1	360,1
Pa (kW)	19,56	23,19	26,49	28,23	32,96	35,76	40,99	46,99	54,6	66,1	77,69	84,14	96,13
Qn (m ³ /h)	12,79	14,96	17,12	19,13	22,28	24,32	28,02	31,80	36,22	43,02	50,17	55	62
Δp (kPa)	15,10	16,75	18,40	22,68	17,13	20,23	18,20	15,0	19,50	22,60	6,70	8,40	8,70

Pa = Total absorbed power
 Pr = Total recovered capacity
 Qn = Water flow rate
 Δp = Pressure drop

13.1.3 TOTAL RECOVERY FILTER PRESSURE DROPS

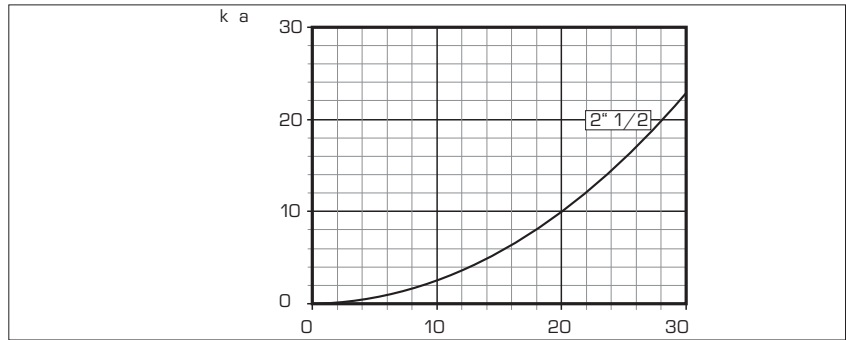

14 FAN UNIT

14.1 MOTOR SIZE AND FIXED PULLEY FOR FAN UNIT (VERSION STANDARD)

0275				0300			0325			0350			0500		
Qa = 16000 m ³ /h				22000 m ³ /h			22000 m ³ /h			26000 m ³ /h			27000 m ³ /h		
PSU	RPM	Pe	Ø2	RPM	Pe	Ø2	RPM	Pe	Ø2	RPM	Pe	Ø2	RPM	Pe	Ø2
(Pa)	(g/min)	(kW)	(mm)	(g/min.)	(kW)	(mm)	(g/min.)	(kW)	(mm)	(g/min.)	(kW)	(mm)	(g/min.)	(kW)	(mm)
0	635	2,44	250	565	2,91	250	565	2,91	250	592	4,07	300	604	4,64	250
20	660	2,59	250	583	3,05	250	583	3,05	250	612	4,30	300	621	4,86	250
40	685	2,73	225	601	3,21	250	601	3,21	250	631	4,52	300	639	5,10	250
60	709	2,88	225	619	3,36	250	619	3,36	250	650	4,74	300	656	5,32	250
80	733	3,04	225	637	3,51	250	637	3,51	250	669	4,99	250	673	5,56	225
100	756	3,20	200	654	3,68	225	654	3,68	225	688	5,22	250	691	5,80	225
120	780	3,29	200	672	3,85	225	672	3,85	225	706	5,45	250	708	6,05	225
140	802	3,46	200	690	4,01	225	690	4,01	225	725	5,70	250	724	6,29	225
160	825	3,62	180	706	4,18	225	706	4,18	225	743	5,83	250	741	6,39	200
180	848	3,80	180	723	4,36	225	723	4,36	225	761	6,08	225	757	6,63	200
200	869	3,98	180	740	4,45	200	740	4,45	200	779	6,32	225	774	6,86	200
220	891	4,15	180	757	4,60	200	757	4,60	200	795	6,55	225	790	7,10	200
240	913	4,24	180	773	4,79	200	773	4,79	200				806	7,36	200
260	934	4,43	180	789	4,97	200	789	4,97	200				822	7,60	200
280	953	4,60	200	805	5,14	200	805	5,14	200				837	7,86	180
300	975	4,79	200	821	5,31	200	821	5,31	200				853	8,12	180
320	996	4,98	200	836	5,49	180	836	5,49	180				868	8,38	180
340	1016	5,16	200	851	5,66	180	851	5,66	180				883	8,47	180
360				866	5,84	180	866	5,84	180				898	8,72	180
380				881	6,01	180	881	6,01	180				913	8,98	200
400				895	6,08	200	895	6,08	200				927	9,23	200
420				909	6,25	200	909	6,25	200				942	9,51	200
440													956	9,77	200

- Standard motor
- Extra power motor 1
- Extra power motor 2

RPM = Fan speed
 Pe = Fan motor power.
 ø2 = Diameter of the fixed pulley.
 PSU = usefull airside static pressure.

The features relating to the Table above are obtained with different diameter pulleys.
 This variation is to be requested when placing the order; consult the head office.

0550				0600			0650			0700		
Qa = 27000 m ³ /h				45000 m ³ /h			45000 m ³ /h			50000 m ³ /h		
PSU	RPM	Pe	Ø2	RPM	Pe	Ø2	RPM	Pe	Ø2	RPM	Pe	Ø2
(Pa)	(g/min)	(kW)	(mm)	(g/min.)	(kW)	(mm)	(g/min.)	(kW)	(mm)	(g/min.)	(kW)	(mm)
0	604	4,64	250	680	9,92	225	680	9,92	225	700	12,14	225
20	621	4,86	250	700	10,32	225	700	10,32	225	734	12,50	225
40	639	5,10	250	720	10,75	225	720	10,75	225	748	12,89	200
60	656	5,32	250	740	11,01	200	740	11,01	200	763	13,31	200
80	673	5,56	225	755	11,36	200	755	11,36	200	777	13,74	200
100	691	5,80	225	770	11,72	200	770	11,72	200	791	13,88	225
120	708	6,05	225	786	12,14	200	786	12,14	200	805	14,30	225
140	724	6,29	225	801	12,53	200	801	12,53	200	819	14,72	225
160	741	6,39	200	816	12,92	200	816	12,92	200	833	15,14	225
180	757	6,63	200	831	13,31	180	831	13,31	180	847	15,56	225
200	774	6,86	200	846	13,74	180	846	13,74	180	861	15,98	225
220	790	7,10	200	860	13,88	200	860	13,88	200	874	16,43	200
240	806	7,36	200	875	14,30	200	875	14,30	200	888	16,85	200
260	822	7,60	200	889	14,65	200	889	14,65	200	902	17,27	200
280	837	7,86	180	903	15,10	200	903	15,10	200	915	17,72	200
300	853	8,12	180	918	15,52	200	918	15,52	200	928	18,14	200
320	868	8,38	180	932	15,94	200	932	15,94	200	942	18,59	200
340	883	8,47	180	945	16,36	200	945	16,36	200	955	19,05	200
360	898	8,72	180	959	16,74	200	959	16,74	200			
380	913	8,98	200									
400	927	9,23	200									
420	942	9,51	200									
440	956	9,77	200									

0750				0800			0900			1000		
Qa = 50000 m ³ /h				60000 m ³ /h			68000 m ³ /h			68000 m ³ /h		
PSU	RPM	Pe	Ø2	RPM	Pe	Ø2	RPM	Pe	Ø2	RPM	Pe	Ø2
(Pa)	(g/min)	(kW)	(mm)	(g/min.)	(kW)	(mm)	(g/min.)	(kW)	(mm)	(g/min.)	(kW)	(mm)
0	700	12,14	225	761	15,34	200	800	19,40	225	861	21,91	200
20	734	12,50	225	776	15,86	200	814	19,95	225	874	22,47	200
40	748	12,89	200	791	16,38	200	827	20,51	225	888	23,07	200
60	763	13,31	200	806	16,90	200	841	20,93	225	901	23,63	200
80	777	13,74	200	821	17,42	200	855	21,63	225	915	24,23	200
100	791	13,88	225	836	17,99	200	868	22,23	225	928	24,41	200
120	805	14,30	225	850	18,03	225	882	22,79	200	941	24,96	200
140	819	14,72	225	865	18,70	225	895	23,40	200	954	25,55	200
160	833	15,14	225	879	19,21	200	909	23,95	200	967	26,15	200
180	847	15,56	225	893	19,77	200	922	24,56	200	980	26,74	200
200	861	15,98	225	908	19,77	200	935	25,16	200	993	27,34	200
220	874	16,43	200	922	20,33	200	948	25,72	200			
240	888	16,85	200	936	20,84	200	961	26,33	200			
260	902	17,27	200	950	21,40	200	974	26,93	200			
280	915	17,72	200	963	21,95	200						
300	928	18,14	200									
320	942	18,59	200									
340	955	19,05	200									

□ Standard motor

■ Extra power motor 1

■ Extra power motor 2

RPM = Fan speed

Pe = Fan motor power.

Ø2 = Diameter of the fixed pulley.

PSU = usefull airside static pressure.

The features relating to the Table above are obtained with different diameter pulleys.

This variation is to be requested when placing the order; consult the head office.

14.2 MOTOR SIZE AND FIXED PULLEY FOR FAN UNIT (LOW NOISE MODELS)

0275				0300			0325			0350			0500		
Qa = 11000 m ³ /h				15500 m ³ /h			15500 m ³ /h			18000 m ³ /h			19000 m ³ /h		
PSU	RPM	Pe	Ø2	RPM	Pe	Ø2	RPM	Pe	Ø2	RPM	Pe	Ø2	RPM	Pe	Ø2
(Pa)	(g/min)	(kW)	(mm)	(g/min.)	(kW)	(mm)	(g/min.)	(kW)	(mm)	(g/min.)	(kW)	(mm)	(g/min.)	(kW)	(mm)
0	525	1,09	280	496	1,48	300	496	1,48	300	501	1,95	300	497	2,12	300
20	560	1,20	280	520	1,61	300	520	1,61	300	527	2,12	300	521	2,30	300
40	592	1,32	250	544	1,73	280	544	1,73	280	553	2,30	300	544	2,47	280
60	624	1,46	250	566	1,85	280	566	1,85	280	578	2,47	250	567	2,64	280
80	654	1,58	250	588	1,98	280	588	1,98	280	602	2,66	250	589	2,84	280
100	684	1,72	225	610	2,10	250	610	2,10	250	626	2,89	250	611	3,01	250
120	713	1,85	225	630	2,24	250	630	2,24	250	649	3,03	250	632	3,21	250
140	742	2,00	225	651	2,37	250	651	2,37	250	671	3,22	250	653	3,41	250
160	770	2,14	200	670	2,50	250	670	2,50	250	693	3,42	225	674	3,60	250
180	797	2,24	200	689	2,62	225	689	2,62	225	715	3,61	225	694	3,80	225
200	824	2,38	200	708	2,76	225	708	2,76	225	736	3,81	225	713	4,00	225
220	850	2,53	180	726	2,89	225	726	2,89	225	756	3,94	200	732	4,20	225
240	875	2,66	180	744	3,02	225	744	3,02	225	776	4,14	200	751	4,40	225
260	900	2,83	180	761	3,09	200	761	3,09	200	796	4,35	200	769	4,59	200
280	924	2,97	180	778	3,21	200	778	3,21	200				787	4,72	200
300	948	3,13	180	794	3,34	200	794	3,34	200				805	4,91	200
320				810	3,47	200	810	3,47	200				822	5,13	200
340				826	3,59	200	826	3,59	200				839	5,32	200

0550				0600			0650			0700		
Qa = 19000 m ³ /h				31500 m ³ /h			31500 m ³ /h			35000 m ³ /h		
PSU	RPM	Pe	Ø2	RPM	Pe	Ø2	RPM	Pe	Ø2	RPM	Pe	Ø2
(Pa)	(g/min)	(kW)	(mm)	(g/min.)	(kW)	(mm)	(g/min.)	(kW)	(mm)	(g/min.)	(kW)	(mm)
0	497	2,12	300	598	5,00	250	598	5,00	250	642	6,28	250
20	521	2,30	300	618	5,30	250	618	5,30	250	661	6,60	250
40	544	2,47	280	639	5,59	250	639	5,59	250	679	6,93	225
60	567	2,64	280	659	5,89	250	659	5,89	250	698	7,26	225
80	589	2,84	280	678	6,22	225	678	6,22	225	715	7,62	225
100	611	3,01	250	698	6,52	225	698	6,52	225	733	7,94	225
120	632	3,21	250	717	6,85	225	717	6,85	225	751	8,31	200
140	653	3,41	250	735	7,15	225	735	7,15	225	768	8,63	200
160	674	3,60	250	753	7,48	200	753	7,48	200	786	8,96	200
180	694	3,80	225	771	7,65	200	771	7,65	200	802	9,32	200
200	713	4,00	225	789	7,98	200	789	7,98	200	819	9,69	180
220	732	4,20	225	806	8,31	200	806	8,31	200	836	10,01	180
240	751	4,40	225	823	8,63	200	823	8,63	200	852	10,37	180
260	769	4,59	200	840	8,96	180	840	8,96	180			
280	787	4,72	200	856	9,29	180	856	9,29	180			
300	805	4,91	200	873	9,65	180	873	9,65	180			
320	822	5,13	200									
340	839	5,32	200									

- Standard motor
- Extra power motor 1
- Extra power motor 2

RPM = Fan speed
 Pe = Fan motor power.
 ø2 = Diameter of the fixed pulley.
 PSU = usefull airside static pressure.

The features relating to the Table above are obtained with different diameter pulleys.
 This variation is to be requested when placing the order; consult the head office.

0750				0800			0900			1000		
Qa = 35000 m3/h				42000 m3/h			47600 m3/h			47600 m3/h		
PSU	RPM	Pe	Ø2	RPM	Pe	Ø2	RPM	Pe	Ø2	RPM	Pe	Ø2
(Pa)	(g/min)	(kW)	(mm)	(g/min.)	(kW)	(mm)	(g/min.)	(kW)	(mm)	(g/min.)	(kW)	(mm)
0	642	6,28	250	629	7,26	225	643	8,89	225	689	10,02	225
20	661	6,60	250	649	7,65	225	662	9,28	225	708	10,21	225
40	679	6,93	225	669	8,10	225	680	9,78	225	725	10,69	225
60	698	7,26	225	688	8,49	225	698	10,22	225	743	11,12	200
80	715	7,62	225	707	8,94	225	717	10,45	225	761	11,61	200
100	733	7,94	225	726	9,33	225	734	10,88	200	778	12,04	200
120	751	8,31	200	744	9,78	200	752	11,37	200	795	12,53	200
140	768	8,63	200	762	10,22	200	769	11,80	200	811	12,96	200
160	786	8,96	200	780	10,40	200	786	12,29	200	828	13,45	200
180	802	9,32	200	798	10,83	200	803	12,77	180	844	13,93	180
200	819	9,69	180	815	11,32	200	820	13,20	180	860	14,11	180
220	836	10,01	180	832	11,75	180	836	13,69	180	876	14,58	180
240	852	10,37	180	848	12,19	180	852	13,87	180	891	15,05	180
260				865	12,62	180	868	14,34	180			
280				881	13,11	180	883	14,82	180			

- Standard motor
- Extra power motor 1
- Extra power motor 2

RPM = Fan speed
Pe = Fan motor power.
ø2 = Diameter of the fixed pulley.
PSU = usefull airside static pressure.

The features relating to the Table above are obtained with different diameter pulleys.
This variation is to be requested when placing the order; consult the head office.

Motor power for standard and extra power versions														
		0275	0300	0325	0350	0500	0550	0600	0650	0700	0750	0800	0900	1000
Standard Version	[kW]	3	4	4	5,5	2X3	2X3	3X4	3X4	3X4	3X4	4X4	4X5,5	4X5,5
Extra Power 1	[kW]	4	5,5	5,5	7,5	2X4	2X4	3X5,5	3X5,5	3X5,5	3X5,5	4X5,5	4X7,5	4X7,5
Extra Power 2	[kW]	5,5	7,5	7,5	-	2X5,5	2X5,5	-	-	3X7,5	3X7,5	-	-	-
Low noise models (L)														
		0275	0300	0325	0350	0500	0550	0600	0650	0700	0750	0800	0900	1000
Standard Version	[kW]	2,2	3	3	4	2X2,2	2X2,2	3X2,2	3X2,2	3X2,2	3X2,2	4X2,2	4X2,2	4X2,2
Extra Power 1	[kW]	3	4	4	-	2X3	2X3	3X3	3X3	3X3	3X3	4X3	4X3	4X3
Extra Power 2	[kW]	-	-	-	-	-	-	-	-	-	-	-	4X4	4X4

15 SOUND DATA

Sound Power

Aermec determines the value of sound power on the basis of measurements performed in compliance with regulation 96/14, in respect with that requested by Eurovent certification.

(1) Sound Pressure

Sound pressure in free field on a reflective surface (factor of directionality Q=2), at 10 metres from the external surface of the unit, using the parallel expansion method (box-method, ISO 3744)

KEY

Operating conditions:
Evaporator water (in/out) 12/7 °C
Condenser water 35 °C

NOTE

Given data refer to cooling operation working conditions.

[°]	Total sound levels			Octave band[Hz]						
	Sound power dB (A)	Sound pressure		125	250	500	1000	2000	4000	8000
		dB (A) 10 m	dB 1 m							
Sound power band middle frequency (db)										
0275	85	53,0	67	82,2	80,7	81,6	78,9	78,6	75,1	65,9
0300	85	53,0	67	82,2	80,7	81,6	78,9	78,6	75,1	65,9
0325	85,5	54,0	67,5	84,4	79,5	80,2	80,6	79,9	75,9	68
0350	88,5	56,0	70,5	86,6	81,3	83,9	82,3	83,2	78,9	70,1
0500	88	56,0	70	85,8	81,6	83,6	81,8	83	78,7	70
0550	88	56,0	70	85,2	82,1	84,8	82,4	82,5	78,2	70,7
0600	90	58,0	72	89,4	84,2	85,4	84,1	84,2	80,8	71,8
0650	90	58,0	72	89,4	84,2	85,4	84,1	84,2	80,8	71,8
0700	91	59,0	73	86,8	85,5	87	85,1	84,6	82,5	73,9
0750	91	59,0	73	90,2	85,8	87,2	85,4	85,4	82,9	74,1
0800	92	60,0	74	91,5	86,1	87,8	85,9	85,9	83,7	74,6
0900	92,5	60,0	74,5	91,5	86,8	88,4	86,5	86,1	84,1	74,6
1000	92,5	60,0	74,5	91,5	86,8	88,4	86,5	86,1	84,1	74,6

[L]	Total sound levels			Octave band[Hz]						
	Sound power dB (A)	Sound pressure		125	250	500	1000	2000	4000	8000
		dB (A) 10 m	dB 1 m							
Sound power band middle frequency (db)										
0275	81	49	63	78	76,5	77,2	74,9	74,7	72,2	61,0
0300	81	49	63	78	76,5	77,2	74,9	74,7	72,2	61
0325	82	50	64	79,4	76,8	76,5	77	76,2	72,1	64,2
0350	84	52	66	81,6	76,6	78,9	77,7	78,9	74,9	66,1
0500	84	52	66	81	76,8	78,5	77,9	79	75	66,2
0550	84	52	66	81	76,8	78,5	77,9	79	75	66,2
0600	86	54	68	83,3	81,4	83,3	80,7	79,2	75,5	66,4
0650	86	54	68	83,3	81,4	83,3	80,7	79,2	75,5	66,4
0700	87	55	69	82,4	82,2	84,6	81,6	79,6	77,2	68,5
0750	87	55	69	82,4	82,2	84,6	81,6	79,6	77,2	68,5
0800	88	56	70	86,5	83,1	85,4	82,4	80,8	78,4	69,2
0900	88,5	56,5	70,5	86,5	83,8	86,1	83,1	81,1	78,8	69,2
1000	88,5	56,5	70,5	86,5	83,8	86,1	83,1	81,1	78,8	69,2

[H]	Total sound levels			Octave band[Hz]						
	Sound power dB (A)	Sound pressure		125	250	500	1000	2000	4000	8000
		dB (A) 10 m	dB 1 m							
Sound power band middle frequency (db)										
0275	84,9	53,0	66,9	82,2	80,7	81,6	78,9	78,6	75,1	65,9
0300	84,9	53,0	66,9	82,2	80,7	81,6	78,9	78,6	75,1	65,9
0325	85,6	54,0	67,6	84,4	79,5	80,2	80,6	79,9	75,9	68
0350	88,4	56,0	70,4	86,6	81,3	83,9	82,3	83,2	78,9	70,1
0500	88,2	56,0	70,2	85,8	81,6	83,6	81,8	83	78,7	70
0550	88,3	56,0	70,3	85,2	82,1	84,8	82,4	82,5	78,2	70,7
0600	90	58,0	72	89,4	84,2	85,4	84,1	84,2	80,8	71,8
0650	90	58,0	72	89,4	84,2	85,4	84,1	84,2	80,8	71,8
0700	91	59,0	73	86,8	85,5	87	85,1	84,6	82,5	73,9
0750	91	59,0	73	90,2	85,8	87,2	85,4	85,4	82,9	74,1
0800	92	60,0	74	91,5	86,1	87,8	85,9	85,9	83,7	74,6
0900	92,5	60,0	74,5	91,5	86,8	88,4	86,5	86,1	84,1	74,6
1000	92,5	60,0	74,5	91,5	86,8	88,4	86,5	86,1	84,1	74,6

16 CAPACITY CONTROL

16.1 STANDARD VERSIONS (°)

Cooling capacity %	Levels of power			
Versions	1°	2°	3°	4°
0275	50	100	-	-
0300	57/43	100	-	-
0325	50	100	-	-
0350	50	100	-	-
0500	39	78	100	-
0550	38	76	100	-
0600	30	61	80	100
0650	30	61	80	100
0700	30	61	80	100
0750	30	61	80	100
0800	30	60	80	100
0900	30	60	80	100
1000	30	60	80	100
Input power %	Levels of power			
0275	50	100	-	-
0300	57/43	100	-	-
0325	50	100	-	-
0350	50	100	-	-
0500	37	69	100	-
0550	34	68	100	-
0600	30	61	80	100
0650	30	61	80	100
0700	30	61	80	100
0750	30	61	80	100
0800	30	60	80	100
0900	30	60	80	100
1000	30	60	80	100

16.2 HEAT PUMP VERSIONS (H)

Heating capacity %	Levels of power			
Versions	1°	2°	3°	4°
0275	50	100	-	-
0300	57/43	100	-	-
0325	50	100	-	-
0350	50	100	-	-
0500	37	75	100	-
0550	36	73	100	-
0600	30	61	80	100
0650	30	61	80	100
0700	30	61	80	100
0750	30	61	80	100
0800	30	60	80	100
0900	30	60	80	100
1000	30	60	80	100
Input power %	Levels of power			
0275	50	100	-	-
0300	57/43	100	-	-
0325	50	100	-	-
0350	50	100	-	-
0500	37	69	100	-
0550	34	68	100	-
0600	30	61	80	100
0650	30	61	80	100
0700	30	61	80	100
0750	30	61	80	100
0800	30	60	80	100
0900	30	60	80	100
1000	30	60	80	100

Cooling mode

- Temperature of processed water 7 °C
 - Ambient air temperature 35 °C

Heating mode

- Temperature of processed water 50 °C
 - Ambient air temperature b.s. 7 °C/ b.u. 6 °C

17 CALIBRATION OF CHECK AND SAFETY PARAMETERS

17.1 CHECK PARAMETERS

NOTE

[1] = Version Y

		min.	standard	max.
Cooling set point	°C	4 / -6 ⁽¹⁾	7 / -6 ⁽¹⁾	14
Heating set point	°C	35	48	50
Antifreeze intervention	°C	-9	3	4
Total differential	°C	3	5	10
Autostart		auto		

THERMOMAGNETIC SWITCHES FANS

Version	0275	0300	0325	0350	0500	0550	0600	0650	0700	0750	0800	0900	1000
(°) (A)	7,2	9	9	12	7,2X2	7,2X2	7,2X3	7,2X3	9X3	9X3	9X4	9X4	12X4
L (A)	7,2	9	9	12	7,2X2	7,2X2	-	-	-	-	-	-	-

THERMOMAGNETIC SWITCHES COMPRESSORS (STANDARD VERSION - LOW NOISE VERSION)

	0275	0300	0325	0350	0500	0550	0600	0650	0700	0750	0800	0900	1000
A	22X2	22	28X2	33X2	22X2	22	20X2	25X4	30X4	39X2	39X4	39X2	48X4
		28			33	28	25X2			30X2		48X2	
						33							

HIGH PRESSURE SWITCH (STANDARD AND SILENCED VERSIONS)

	0275	0300	0325	0350	0500	0550	0600	0650	0700	0750	0800	0900	1000
(bar)	28	28	28	28	28	28	28	28	28	28	28	28	28

LOW PRESSURE SWITCH (STANDARD AND SILENCED VERSIONS)

	0275	0300	0325	0350	0500	0550	0600	0650	0700	0750	0800	0900	1000
(bar)	2	2	2	2	2	2	2	2	2	2	2	2	2

HIGH PRESSURE TRANSDUCER (STANDARD VERSION - LOW NOISE VERSION)

	0275	0300	0325	0350	0500	0550	0600	0650	0700	0750	0800	0900	1000
(bar)	28	28	28	28	28	28	28	28	28	28	28	28	28

FAN THERMOMAGNETIC SWITCHES

Versione	0275	0300	0325	0350	0500	0550	0600	0650	0700	0750	0800	0900	1000
H (A)	7,2	9	9	12	7,2X2	7,2X2	7,2X3	7,2X3	9X3	9X3	9X4	9X4	12X4

COMPRESSOR THERMOMAGNETIC SWITCH (HEAT PUMP VERSIONS)

	0275	0300	0325	0350	0500	0550	0600	0650	0700	0750	0800	0900	1000
(A)	22X2	22	28X2	33X2	22X2	22	20X2	25X4	30X4	39X2	39X4	39X2	48X4
		28			33	28	25X2			30X2		48X2	
						33							

MAIN SWITCH

Versione	0275	0300	0325	0350	0500	0550	0600	0650	0700	0750	0800	0900	1000
(A)	80	80	100	100	125	125	200	200	200	250	315	315	350

HIGH PRESSURE SWITCH (HEAT PUMP VERSIONS)

	0275	0300	0325	0350	0500	0550	0600	0650	0700	0750	0800	0900	1000
(bar)	28	28	28	28	28	28	28	28	28	28	28	28	28

HIGH PRESSURE TRANSDUCER (HEAT PUMP VERSIONS)

	0275	0300	0325	0350	0500	0550	0600	0650	0700	0750	0800	0900	1000
(bar)	28	28	28	28	28	28	28	28	28	28	28	28	28

LOW PRESSURE TRANSDUCER (HEAT PUMP VERSIONS)

	0275	0300	0325	0350	0500	0550	0600	0650	0700	0750	0800	0900	1000
(bar)	1	1	1	1	1	1	1	1	1	1	1	1	1

18 DIMENSIONS

18.1 DIMENSION TABLES

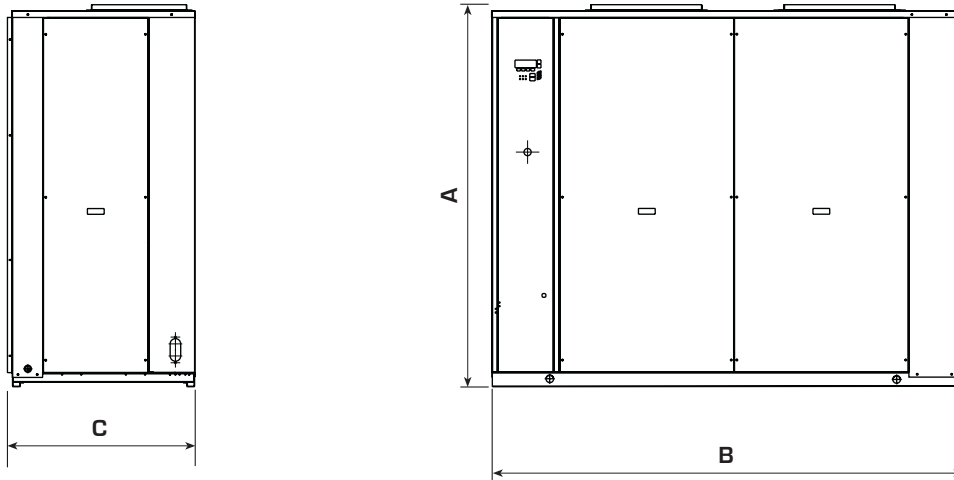

DIMENSIONS OF STANDARD, SILENCED AND HEAT PUMP VERSIONS NRC 00 - P1 - P2 - P3 - P4														
MODEL		0275	0300	0325	0350	0500	0550	0600	0650	0700	0750	0800	0900	1000
A	mm	1763	1793	1793	1763	1963	1963	2288	2288	2288	2288	2295	2295	2295
B	mm	2100	2100	2100	2450	2450	2450	3750	3750	4550	4550	4950	4950	4950
C	mm	950	950	950	950	950	950	1100	1100	1100	1100	1300	1300	1300

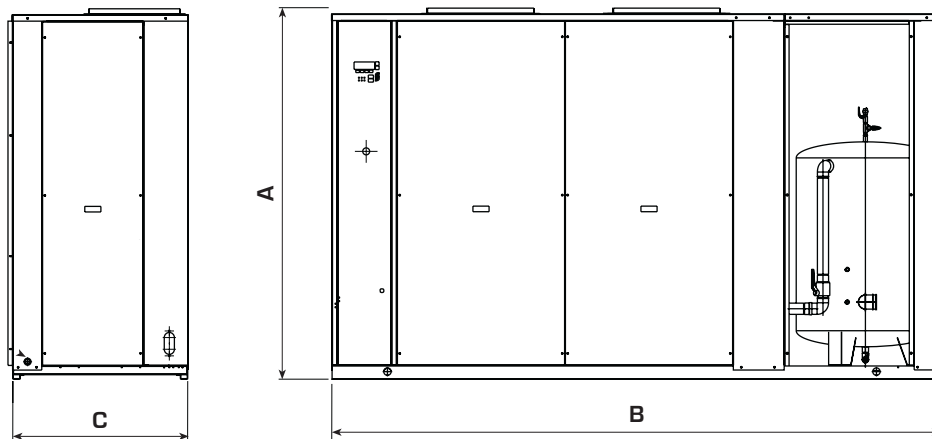

DIMENSIONS OF STANDARD, SILENCED AND HEAT PUMP VERSIONS WITH STORAGE TANK NRC 01 - 02 - 03 - 04 - 05 - 06 - 07 - 08														
MODEL		0275	0300	0325	0350	0500	0550	0600	0650	0700	0750	0800	0900	1000
A	mm	1763	1793	1793	1763	1963	1963	2288	2288	2288	2288	2295	2295	2295
B	mm	2950	2950	2950	3300	3300	3300	4550	4550	5350	5350	5750	5750	5750
C	mm	950	950	950	950	950	950	1100	1100	1100	1100	1300	1300	1300

18.2 MINIMUM TECHNICAL CLEARANCES

[mm]	A	B	C	D
NRC 0275	1100	800	800	800
NRC 0300	1100	800	800	800
NRC 0325	1100	800	800	800
NRC 0350	1100	800	800	800
NRC 0500	1100	800	800	800
NRC 0550	1100	800	800	800
NRC 0600	1100	800	800	800
NRC 0650	1100	800	800	800
NRC 0700	1100	800	800	800
NRC 0750	1100	800	800	800
NRC 0800	1100	800	800	800
NRC 0900	1100	800	800	800
NRC 1000	1100	800	800	800

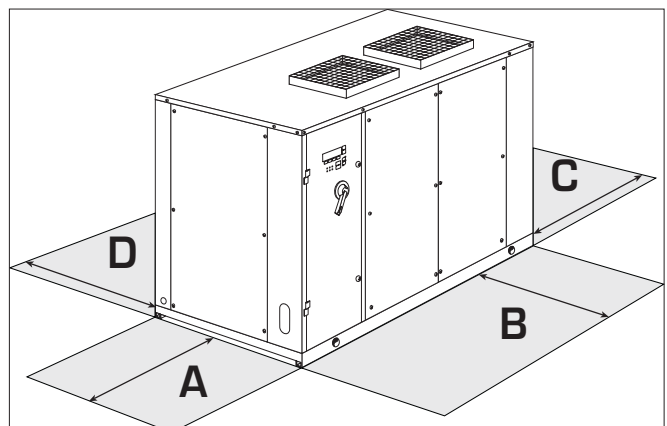

19 WEIGHTS AND CENTRES OF MASS

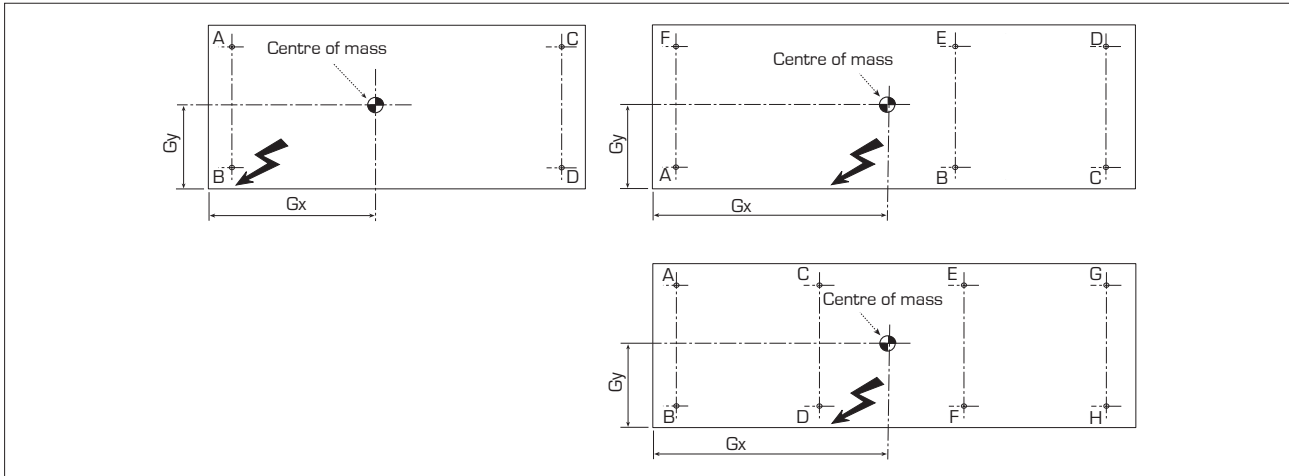

STANDARD VERSION (°) ⁽¹⁾ - WITHOUT STORAGE TANK

Size		0275	0300	0325	0350	0500	0550	0600	0650	0700	0750	0800	0900	1000
Weight	Kg	629	665	699	777	904	919	1481	1498	1737	1918	2670	2700	2960
Gx	[mm]	1132	1142	1124	1310	1279	1279	1883	1891	2193	2206	2233	2236	2259
Gy	[mm]	390	389	388	398	396	396	493	490	493	496	480	482	466
A	%	18,9	18,7	19,0	19,5	19,9	19,9	21	21	12	12	19	19	19
B	%	27,2	26,9	27,5	27,0	27,9	27,9	21	21	31	31	15	15	15
C	%	22,1	22,3	21,8	22,4	21,7	21,7	29	29	7	7	22	22	21
D	%	31,8	32,1	31,7	31,1	30,5	30,5	29	29	7	7	17	17	17
E	%	-	-	-	-	-	-	-	-	31	31	4	4	5
F	%	-	-	-	-	-	-	-	-	12	12	4	4	4
G	%	-	-	-	-	-	-	-	-	-	-	11	11	11
H	%	-	-	-	-	-	-	-	-	-	-	8	8	9

VERSION WITH EMPTY STORAGE TANK

		0275	0300	0325	0350	0500	0550	0600	0650	0700	0750	0800	0900	1000
Gx	[mm]	1425	1420	1395	1579	1518	1518	2203	2203	2535	2518	2476	2476	2479
Gy	[mm]	407	405	405	430	409	409	507	505	505	507	503	505	489

VERSION WITH PUMP UNIT ONLY

Size		0275	0300	0325	0350	0500	0550	0600	0650	0700	0750	0800	0900	1000
Weight	[kg]	663	699	733	811	938	953	1659	1676	1914	2096	2870	2900	3160

VERSION WITH STORAGE TANK FULL OF WATER (500/700 litri) ⁽²⁾

Size		0275	0300	0325	0350	0500	0550	0600	0650	0700	0750	0800	0900	1000
Weight	Kg	1327	1391	1401	1496	1621	1638	2243	2260	2498	2680	3770	3800	4050
Gx	[mm]	1839	1817	1798	2012	1931	1931	2203	2203	2535	2518	3012	3008	2975
Gy	[mm]	432	430	430	445	429	429	507	505	505	507	491	492	480
A	%	17,1	17,4	17,7	18,3	18,7	18,7	12	12	13	13	16	16	16
B	%	20,5	21,0	21,4	20,7	22,8	22,8	12	12	13	13	9	9	9
C	%	28,4	27,9	27,6	28,6	26,4	26,4	31	31	25	25	17	17	18
D	%	34,0	33,7	33,4	32,4	32,1	32,1	31	31	25	25	9	9	10
E	%	-	-	-	-	-	-	7	7	12	12	13	13	14
F	%	-	-	-	-	-	-	7	7	12	12	7	7	7
G	%	-	-	-	-	-	-	-	-	-	-	18	18	18
H	%	-	-	-	-	-	-	-	-	-	-	10	10	10

HEAT PUMP VERSIONS (H) ⁽¹⁾

Size		0275H	0300H	0325H	0350H	0500H	0550H	0600H	0650H	0700H	0750H	0800H	0900H	1000H
Peso	Kg	689	737	748	841	983	999	1593	1610	1931	2001	2797	2827	3095
Gx	[mm]	1108	1126	1098	1300	1271	1271	1883	1886	2187	2200	2244	2247	2268
Gy	[mm]	402	396	398	431	411	411	506	504	504	503	487	489	473
A	%	20,0	19,4	20,0	21,3	20,8	20,8	21	21	12	12	19	19	19
B	%	27,3	27,0	27,8	25,7	27,3	27,3	21	21	12	12	15	15	15
C	%	22,3	22,4	21,9	24,1	22,4	22,4	29	29	31	31	22	22	24
D	%	30,4	31,2	30,4	29,0	29,4	29,4	29	29	31	31	17	17	17
E	%	-	-	-	-	-	-	-	-	7	7	4	4	5
F	%	-	-	-	-	-	-	-	-	7	7	4	4	4
G	%	-	-	-	-	-	-	-	-	-	-	11	11	11
H	%	-	-	-	-	-	-	-	-	-	-	8	8	9

VERSION WITH PUMP UNIT ONLY (HEAT PUMP MODELS)														
Size		0275H	0300H	0325H	0350H	0500H	0550H	0600H	0650H	0700H	0750H	0800H	0900H	1000H
Weight	[kg]	723	771	782	875	1017	1033	1771	1788	2009	2179	2997	3027	3295
VERSION WITH EMPTY STORAGE TANK ⁽²⁾ (HEAT PUMP MODELS)														
Size		0275H	0300H	0325H	0350H	0500H	0550H	0600H	0650H	0700H	0750H	0800H	0900H	1000H
Gx	[mm]	1396	1396	1396	1565	1503	1503	2036	2187	2515	2502	2475	2475	2476
Gy	[mm]	418	411	412	439	420	420	518	515	514	513	508	509	493
VERSION WITH STORAGE TANK FULL OF WATER (500/700 litres) ⁽²⁾ (HEAT PUMP MODELS)														
Size		0275H	0300H	0325H	0350H	0500H	0550H	0600H	0650H	0700H	0750H	0800H	0900H	1000H
Weight	Kg	1365	1420	1430	1530	1694	1710	2355	2372	2593	2763	3890	3920	4182
Gx	[mm]	1809	1793	1773	1993	1859	1859	2036	2187	2515	2502	2994	2990	2959
Gy	[mm]	439	434	434	451	449	449	518	515	514	513	495	496	484
A	%	17,9	17,9	18,2	18,8	20,7	20,7	12	12	13	13	19	19	19
B	%	20,8	21,3	21,7	20,8	23,0	23,0	12	12	13	13	15	15	15
C	%	28,4	27,7	27,5	28,7	26,6	26,6	31	31	25	25	22	22	24
D	%	33,0	33,0	32,6	31,7	29,7	29,7	31	31	25	25	17	17	17
E	%	-	-	-	-	-	-	7	7	12	12	4	4	5
F	%	-	-	-	-	-	-	7	7	12	12	4	4	4
G	%	-	-	-	-	-	-	-	-	-	-	11	11	11
H	%	-	-	-	-	-	-	-	-	-	-	8	8	9
SILENCED VERSION WITHOUT STORAGE TANK ⁽¹⁾														
Size		0275L	0300L	0325L	0350L	0500L	0550L	0600L	0650L	0700L	0750L	0800L	0900L	1000L
Weight	Kg	638	674	708	786	917,5	932,5	1481	1498	1737	1918	2670	2700	2960
Gx	[mm]	1132	1142	1124	1310	1279	1279	1888	1891	2193	2206	2233	2236	2259
Gy	[mm]	390	389	388	398	396	396	493	490	493	496	480	482	466
A	%	18,9	18,7	19,0	19,5	19,9	19,9	21	21	12	12	19	19	19
B	%	27,2	26,9	27,5	27,0	27,9	27,9	21	21	12	12	15	15	15
C	%	22,1	22,3	21,8	22,4	21,7	21,7	29	29	31	31	22	22	21
D	%	31,8	32,1	31,7	31,1	30,5	30,5	29	29	31	31	17	17	17
E	%	-	-	-	-	-	-	-	-	7	7	4	4	5
F	%	-	-	-	-	-	-	-	-	7	7	4	4	4
G	%	-	-	-	-	-	-	-	-	-	-	11	11	11
H	%	-	-	-	-	-	-	-	-	-	-	8	8	9
VERSION WITH EMPTY STORAGE TANK ⁽²⁾ (SILENCED MODELS)														
Size		0275L	0300L	0325L	0350L	0500L	0550L	0600L	0650L	0700L	0750L	0800L	0900L	1000L
Gx	[mm]	1425	1420	1395	1579	1518	1518	1883	1886	2187	2200	2476	2476	2479
Gy	[mm]	407	405	405	430	409	409	506	504	504	503	503	505	489
VERSION WITH PUMP UNIT ONLY (SILENCED MODELS)														
Size		0275L	0300L	0325L	0350L	0500L	0550L	0600L	0650L	0700L	0750L	0800L	0900L	1000L
Weight	[kg]	672	708	742	820	951,5	966,5	1659	1676	1914	2096	2870	2900	3160
SILENCED VERSION WITH STORAGE TANK FULL OF WATER (500 litres) ⁽²⁾														
Size		0275L	0300L	0325L	0350L	0500L	0550L	0600L	0650L	0700L	0750L	0800L	0900L	1000L
Weight	Kg	1336	1400	1410	1505	1634,5	1651,5	2243	2260	1498	2680	3770	3800	4050
Gx	[mm]	1839	1817	1798	2012	1931	1931	1883	1886	2187	2206	3012	3008	2975
Gy	[mm]	432	430	430	445	429	429	506	504	504	496	491	492	480
A	%	17,1	17,4	17,7	18,3	18,7	18,7	21	21	12	12	16	16	16
B	%	20,5	21,0	21,4	20,7	22,8	22,8	21	21	12	12	9	9	9
C	%	28,4	27,9	27,6	28,6	26,4	26,4	29	29	31	31	17	17	18
D	%	34,0	33,7	33,4	32,4	32,1	32,1	29	29	31	31	9	9	10
E	%	-	-	-	-	-	-	-	-	7	7	13	13	14
F	%	-	-	-	-	-	-	-	-	7	7	7	7	7
G	%	-	-	-	-	-	-	-	-	-	-	18	18	18
H	%	-	-	-	-	-	-	-	-	-	-	10	10	10
DIFFERENT WEIGHTS COMPARED WITH THE STANDARD MODEL (KG)														
Additional weights		0275	0300	0325	0350	0500	0550	0600	0650	0700	0750	0800	0900	1000
For desuperheaters		6,5	7,5	8,5	10	10	12	14	18	18	24	50	53	56
For total recovery unit		45	54	63	63	95	95	105	125	125	150	125	138	145

(1) = Weights and centres of mass referring to the model without storage tank 00, free of water.

(2) = Weights and centres of mass referring to the model with storage tank 04. Models 0800- 0900- 1000 use a 700 litre

storage tank. Versions with desuperheater, and those with storage tank 01 02 03, have different weights compared with the reference model, but the variations in the centre of gravity and weight distribution are negli-

gible. Versions with holes for supplementary heaters (storage tank 05 06 07 08) display negligible differences compared with the reference model.

INSTRUCCIONES PARA LA SELECCIÓN

Declaración de conformidad.....	42
1 Normas generales.....	pag. 43
1.1 Placa técnica.....	pag. 43
2 Descripción y elección de la unidad.....	pag. 44
2.1 Modelos disponibles.....	pag. 44
2.2 Versiones disponibles.....	pag. 44
2.2.1 Dotazioni di serie.....	pag. 44
2.3 Configurador.....	pag. 45
3 Descripción de los componentes.....	pag. 46
3.1 Circuito de refrigeración.....	pag. 46
3.2 Bastidor y ventiladores.....	pag. 46
3.3 Componentes hidráulicos.....	pag. 46
3.4 Componentes de seguridad y de control.....	pag. 47
3.5 Componentes eléctricos.....	pag. 47
3.6 Regulación electrónica.....	pag. 47
4 Accesorios.....	pag. 48
5 Datos técnicos.....	pag. 50
5.1 Condiciones nominales de referencia.....	pag. 50
5.2 Datos técnicos versiones estándar (*).....	pag. 51
5.3 Datos técnicos versiones silenciadas [L].....	pag. 53
5.4 Datos técnicos versiones bomba de calor [H].....	pag. 55
6 Criterios de elección.....	pag. 57
6.1 Límites de funcionamiento.....	pag. 57
6.2 Datos de proyecto.....	pag. 57
7 Coeficientes correctivos.....	pag. 58
7.1 Potencia de refrigeración y absorbida.....	pag. 58
7.2 Potencia de refrigeración y absorbida.....	pag. 58
7.3 Potencia térmica y absorbida.....	pag. 59
7.4 Para Δt diferentes del nominal.....	pag. 60
7.4.1 Factores correctivos para Δt diferentes del nominal chiller.....	pag. 60
7.5 Factores de incrustación.....	pag. 60
7.5.1 Factores de incrustación.....	pag. 60
8 Solución de glicol etilénico.....	pag. 61
8.1 Cómo leer las curvas del glicol.....	pag. 61
9 Pérdidas de carga.....	pag. 63
9.1 Pérdidas de carga evaporador.....	pag. 63
9.1.1 Coeficiente para datos diferentes de los nominales.....	pag. 63
9.2 Pérdidas de carga filtro agua.....	pag. 64
9.3 Características de los filtros.....	pag. 64
10 Acumulación.....	pag. 65
10.1 Contenido máximo de agua de la instalación.....	pag. 65
10.1.1 Calibrado vaso de expansión.....	pag. 65
11 Prevalencias útiles para la instalación.....	pag. 66
11.1 Bombas baja prevalencia.....	pag. 66
11.2 Bombas alta prevalencia.....	pag. 66
12 Desrequeadores.....	pag. 67
12.1 Version estándar.....	pag. 67
12.1.1 Con silenciador.....	pag. 67
12.1.2 Datos nominales versiones estándar - silenciadas - bombas de calor.....	pag. 67
12.2 Valores diferentes del nominal.....	pag. 68
12.3 Pérdidas de carga.....	pag. 68
12.4 Pérdidas de carga filtro desrequeador.....	pag. 68
13 Recuperación total.....	pag. 69
13.1 Pérdidas de carga.....	pag. 69
13.1.1 Valores diferentes del nominal.....	pag. 69
13.1.2 Pérdidas de carga.....	pag. 70
13.1.3 Pérdidas de carga filtro de recuperación total.....	pag. 70
14 Grupo de ventilación.....	pag. 70
14.1 Dimensionamiento motor y polea fija (versiones estándar).....	pag. 70
14.2 Dimensionamiento motor y polea fija (versiones silenciadas).....	pag. 72
15 Datos sonoros.....	pag. 73
16 Parcializaciones.....	pag. 75
16.1 Versiones estándar.....	pag. 75
16.2 Versiones bombas de calor.....	pag. 75
17 Calibrado parámetros de control y de seguridad.....	pag. 76
17.1 Parámetros de control.....	pag. 76
18 Dimensiones.....	pag. 77
18.1 Tablas dimensionales.....	pag. 77
18.2 Espacios técnicos mínimos.....	pag. 77
19 Pesos y baricentros.....	pag. 78

Estimado cliente,

Le agradecemos su elección por un producto AERMEC. Este producto es el resultado de varios años de experiencia y de estudios de proyectación minuciosos, y ha sido construido con materiales de primera calidad y tecnología de vanguardia. Además, la marca CE garantiza que los aparatos cumplan los requisitos de la Directiva Europea Máquinas por lo que se refiere a la seguridad. Nuestro nivel de calidad está sometido a una vigilancia constante, por lo que los productos AERMEC son sinónimo de Seguridad, Calidad y Fiabilidad.

Los datos pueden experimentar modificaciones que se consideren necesarias en cualquier momento y sin la obligación de aviso previo para la mejora del producto.

Gracias de nuevo.
AERMEC S.p.A



AERMEC S.p.A.
I-37040 Bevilacqua (VR) Italia - Via Roma, 44
Tel. (+39) 0442 633111
Telefax 0442 93730 - (+39) 0442 93566
www.aermec.com - info@aermec.com

NRC NRC H

NÚMERO DE SERIE :	
--------------------------	--

DECLARACIÓN DE CONFORMIDAD

Los que suscriben la presente declaran bajo la propia y exclusiva responsabilidad que el conjunto en objeto, definido como sigue:

NOME	NRC
TIPO	ENFRIADORA AIRE/ AGUA, BOMBAS DE CALOR SERIE NRC
MODELO	

Al que se refiere esta declaración es conforme a las siguientes normas armonizadas:

CEI EN 61000-6-2	Immunità e emissioni elettromagnetiche per l'ambiente industriale
CEI EN 61000-6-4	
EN378	Refrigerating system and heat pumps - Safety and environmental requirements
EN12735	Copper and copper alloys - Seamless, round copper tubes for air conditioning and refrigeration
UNI1285-68	Cálculo de resistencia de los tubos metálicos sometidos a presión interna;
EN60204-1	Seguridad de la maquinaria - Equipamiento eléctrico de las máquinas

Satisfaciendo de este modo los requisitos esenciales de las siguientes directivas:

- Directiva LVD: 2006/95/CE
- Directiva compatibilidad electromagnética 2004/108/CE
- Directiva máquinas 98/37/CE
- Directiva PED en materia de equipos a presión 97/23/CE

El producto, en conformidad con la directiva 97/23/CE, satisface el procedimiento de Garantía de Calidad Total (modulo H) con certificado n.06/270-QT3664 Rev.0 emitido por el organismo acreditado n.1131 CEC via Pisacane 46 Legnano (MI) - Italy

Bevilacqua 26/03/2007

Director Comercial
Firma

1 NORMAS GENERALES

- Este manual y los esquemas eléctricos proporcionados junto con la unidad deben conservarse en un lugar seco para posibles consultas futuras y durante toda la duración de la máquina.
- El presente manual de instrucciones ha sido confeccionado con el objetivo de facilitar la correcta instalación de la unidad y proveer las indicaciones necesarias para un uso y mantenimiento correcto del aparato. Antes de proceder con la instalación, le sugerimos que lea con **ATENCIÓN** toda la información contenida en el manual en el que se ilustran los procedimientos necesarios para la instalación y uso correcto de la unidad.
- Aténgase meticulosamente a las instrucciones contenidas en el presente manual y observe las normas vigentes de seguridad.
- La instalación del aparato deberá realizarse de acuerdo con la legislación nacional vigente en el país de destino.
- Manipulaciones no autorizadas del aparato, tanto eléctricas como mecánicas **ANULAN POR COMPLETO LA GARANTÍA** y eximen a la empresa de posibles responsabilidades.
- Compruebe las características eléctricas indicadas en la etiqueta de matrícula (fig.1) antes de realizar las conexiones eléctricas. Lea las instrucciones de la sección relativa a las conexiones eléctricas.

- En caso de necesitar la reparación de la unidad, diríjase exclusivamente a un centro de asistencia especializado AERMEC y utilice siempre piezas de recambio originales.
 - El fabricante declina además cualquier responsabilidad derivada de los daños personales o materiales causados por el no seguimiento del contenido de este manual.
 - Usos permitidos: la serie de enfriadoras en cuestión es idónea para producir agua fría a utilizar en instalaciones hidrónicas con finalidad de acondicionamiento. Las unidades no son adecuadas para producir agua caliente sanitaria. Queda prohibido cualquier uso distinto del permitido o fuera de los límites de funcionamiento citados en el manual, si antes no ha sido acordado con la empresa.
- La garantía no cubre el pago de los daños causados por una instalación defectuosa por parte del instalador.
- La garantía no incluye el pago de daños derivados de un uso inapropiado de la unidad por parte del usuario.
 - La casa fabricante no se considera responsable de accidentes que afecten al instalador o al usuario y que deriven de una instalación o un uso indebido de la unidad.
 - La instalación del aparato deberá realizarse de manera que sean posibles la reparación y/o el mantenimiento del

mismo. La garantía del aparato no cubrirá en ningún caso los costes derivados del uso de escaleras automáticas, andamios o cualquier otro sistema de elevación necesario para realizar las operaciones cubiertas por la garantía.

La garantía no es válida en los siguientes casos:

- si los servicios y reparaciones han sido efectuados por personal y empresas no autorizados;
- si la unidad ha sido reparada o modificada anteriormente con piezas de repuesto no originales;
- si no se ha realizado un mantenimiento adecuado de la unidad;
- si no se han seguido las instrucciones incluidas en el presente manual;
- si se han realizado modificaciones no autorizadas.

NOTA:

El fabricante se reserva el derecho, en todo momento, de efectuar cualquier modificación con el fin de mejorar el producto, y no está obligado a añadir dichas modificaciones a máquinas fabricadas con antelación y ya entregadas o en fase de construcción.

En cualquier modo, las condiciones de garantía están sujetas a las condiciones generales de venta previstas en el momento de la estipulación del contrato.

1.1 Placa técnica

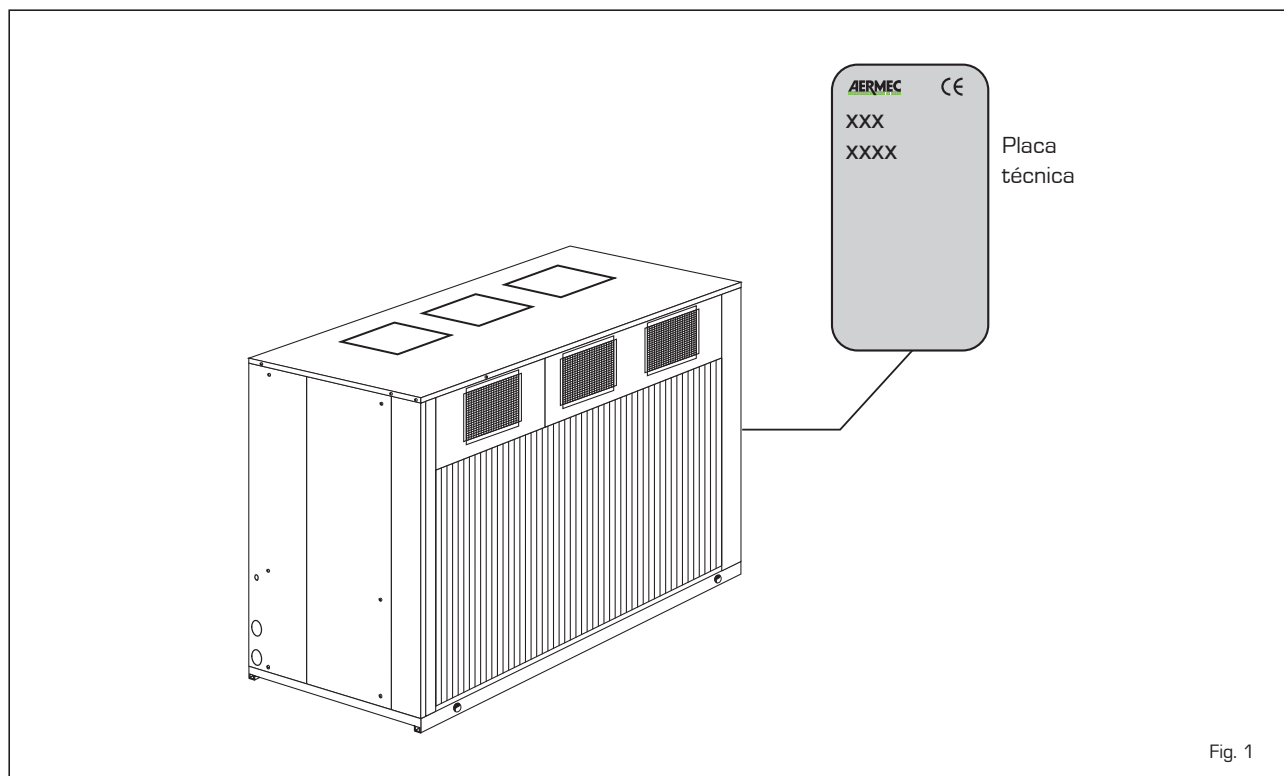

2 DESCRIPCIÓN Y ELECCIÓN DE LA UNIDAD

Los aparatos de la serie NRC son unidades empleadas para la producción de agua fría para instalaciones tecnológicas; son máquinas para interior, cuyos modelos con bomba de calor también permiten producir agua caliente para calentamiento. Están compuestas por dos circuitos frigoríficos de R407C y por un único circuito hidráulico, el cual puede o no estar provisto de grupo de acumulación y/o Kit bomba adicional.

La presencia de varios compresores de tipo scroll permite a los refrigeradores NRC diversas parcializaciones de la potencia de refrigeración (hasta cuatro grados de parcialización). La regulación electrónica con microprocesador controla y gestiona todos los componentes y los parámetros de funcionamiento de la unidad; en el momento en el que surge una condición de alarma, una memoria interna registra las condiciones de funcionamiento para luego visualizarlas en el display. El grado de protección de las unidades es de IP 24.

2.1 MODELOS DISPONIBLES

- BASE (°) representa la configuración obtenida calibrando los intercambiadores con paquete aleteado para permitir un funcionamiento correcto del refrigerador con temperaturas externas no superiores a 46°C.
- SILENCIADA (L) representa los modelos configurados para un funciona-

miento particularmente silencioso. A los compresores se les aplica cubiertas fonoabsorbentes para limitar el ruido, y además poseen grupos de ventilación modificados para obtener un caudal de aire y ruido menores respecto a la versión base.

- "BOMBA DE CALOR BASE (H)" en enfriamiento los límites operativos llegan a una temperatura externa máxima de 46 °C.

2.2 VERSIONES DISPONIBLES

- "RECUPERACIÓN DE CALOR"
El calor que disipan los NRC en el aire mediante las baterías condensadoras, puede ser parcial o totalmente recuperado mediante un adecuado intercambiador en modo de suministrar agua caliente para uso sanitario u otros. En presencia de tal exigencia la máquina se puede configurar con recuperación de calor.

Existen dos posibilidades:

1. Existen dos posibilidades (D)

NOTA:
en los modelos con bomba de calor el desrecalentador debe ser interceptado en el funcionamiento en bomba de calor, bajo pena de anulación de la garantía.

2. Recuperación de calor total (T)

NOTA: es prevista únicamente en las versiones sólo frío (no se encuentra a disposición para las bombas de calor y

las unidades motocondensadoras).

- "MOTOCONDENSADORAS C"
- "MOTOCONDENSADORAS SILENCIADAS LC"

NOTA:

Las versiones motocondensadoras están disponibles para las versiones sólo frío.

- "VERSIONE Y" es la versión que permite producir agua refrigerada por debajo del valor estándar de +4 °C hasta un mínimo de -6 °C. Para valores inferiores póngase en contacto con la sede

NOTA:

el modelo está disponible únicamente para las versiones sólo frío.

ATENCIÓN

Para los aparatos destinados a funcionar a bajas temperaturas y también las bombas de calor, antes de cualquier puesta en funcionamiento de la unidad (o al finalizar cada periodo prolongado de pausa) es extremadamente importante que el aceite del cárter compresor se haya calentado preventivamente, mediante la alimentación de las correspondientes resistencias eléctricas, durante al menos 8 horas. La resistencia cárter se alimenta automáticamente cuando la unidad se detiene, siempre que la unidad se mantenga bajo tensión.

2.2.1 Equipamiento de serie

TODAS LAS VERSIONES ESTÁN EQUIPADAS CON:		TP1	Transductor de baja presión
		TP2	Transductor de alta presión
		ENFRIADORES con ACUMULACIÓN	
1.	Resistencia eléctrica antihielo evaporador	1.	Resistencia eléctrica antihielo evaporador
2.	Resistencia cárter compresor	2.	Grupo de bombeo alta o baja prevalencia
3.	Tablero mando a distancia	3.	El grupo de bombeo de los enfriadores con acumulación puede ser de alta o baja presión de descarga y, como opción, prevé una bomba de reserva controlada por la tarjeta electrónica, que periódicamente gira las bombas existentes, de manera de optimizar sus horas de funcionamiento
4.	Filtro de agua (en la versiones sin acumulación se suministra en dotación)	4.	Para las versiones de bomba de calor está disponible bajo pedido un acumulador preparado para la introducción de resistencias eléctricas complementarias.
5.	Presostato diferencial		
6.	Transductor de alta presión de serie en los modelos del 500 al 1000 (sólo frío)		
7.	Presostato de alta presión		
8.	Presostato de baja presión (de serie en los modelos sólo frío)		
BOMBAS DE CALOR			

NOTA:

Sólo en las versiones bomba de calor se prevé la posibilidad de tener la preinstalación para varias resistencias integradas RX; cuya adquisición, montaje y conexión será a cargo del usuario. Se recuerda además, que tales orificios de preinstalación poseen tapones provisionales de plástico. En caso de que al principio no se coloquen las resistencias eléctricas con los cierres correspondientes, los tapones de plástico deben sustituirse por otros de metal.

2.3 CONFIGURADOR

1,2,3	4,5,6,7	8	9	10	11	12	13	14	15,16
NRC	0500	°	°	D	L	°	°	°	00

campo 1, 2 e 3: **NRC**

NOTAS:

(1) = Para la configuración de estas versiones se recomienda contactar con la sede.

(2) = Sólo en las versiones bomba de calor se prevé la posibilidad de tener la preinstalación para varias resistencias integradas RX; cuya adquisición, montaje y conexión será a cargo del usuario. Se recuerda además, que tales orificios de preinstalación poseen tapones provisorios de plástico. En caso de que al principio no se coloquen las resistencias eléctricas con los cierres correspondientes, los tapones de plástico deben sustituirse por otros de metal.

campo 15 - 16

campo 14

campo 13

campo 12

campo 11

campo 10

campo 9

campo 8

campo 4 - 5 - 6 - 7

KIT HIDRÓNICO	
00	Sin Acumulación
01	Acumulador y bomba baja prevalencia
02	Acumulador bomba baja prevalencia + bomba de reserva
03	Acumulador y bomba alta prevalencia
04	Acumulador bomba alta prevalencia y bomba de reserva
05	Acumulador con orificios para resistencia complementaria y bomba baja prevalencia (2)
06	Acumulador con orificios para resistencia complementaria, bomba baja prevalencia y bomba de reserva. (2)
07	Acumulador con orificios para resistencia complementaria, bomba alta prevalencia. (2)
08	Acumulador con orificios para resistencia complementaria, bomba alta prevalencia y bomba de reserva (2)
P1	Solo bomba baja prevalencia
P2	Bomba baja prevalencia y bomba de reserva
P3	Solo bomba alta prevalencia
P4	Bomba alta prevalencia y bomba de reserva

Alimentación

°	3N~400V-50Hz; compresores protegidos con magnetotérmicos (hasta la versión 0750)
	3~400V-50Hz; compresores protegidos con magnetotérmicos (desde la versión 0800)
4	3~230V-50Hz; compresores protegidos con magnetotérmicos (1)
9	3~500V-50Hz; compresores protegidos con magnetotérmicos (1)

Evaporatore

°	Conforme PED PED
G	Conforme PED TÜV-D (Germania)
C	Sin evaporador (Versión Motocondensador) (sólo frío)

Baterías

°	De aluminio
R	De cobre
S	Cobre estañado
V	Cobre aluminio lacado

Versión

°	Estándar
L	Estándar en ejecución Silenciada (sólo frío)

Recuperadores de calor

°	Sin recuperadores
D	Desrecalentador (1)
T	Recuperación total (sólo frío)(1)

Modelo

°	Sólo frío
H	Bomba de calor

Campo de empleo

°	Estándar
Y	Versión para baja temperatura del agua producida hasta los -6 °C (1)

Dimensiones

0275 • 0300 • 0325 • 0350 • 0500 • 0550 • 0600 • 0650 • 0700 • 0750 • 0800 • 0900 • 1000
--

3 DESCRIPCIÓN DE LOS COMPONENTES

Componentes principales



LEYENDA

- 1 Compresor
- 2 Intercambiador lado agua
- 3 Intercambiador lado aire
- 4 Estructura portante
- 5 Teclado de mando
- 6 Grupo de ventilación
- 7 Contenedor de acumulación
- 8 Vaso de expansión
- 9 Filtro
- 10 Flujostato
- 11 Válvula de seguridad
- 12 Válvula de ventilación
- 13 Sistema de interbloqueo de la puerta
- 14 Tablero control remoto

3.1 CIRCUITO DE REFRIGERACIÓN

Compresores

Compresores herméticos de tipo scroll provistos, de serie, de la resistencia eléctrica cárter compresores. La resistencia se alimenta automáticamente con el paro de la unidad, siempre que la unidad se mantenga bajo tensión. En la versión silenciada L, los compresores están aislados acústicamente mediante coberturas fonoabsorbentes.

Intercambiador lado aire

Está realizado con tubos de cobre y aletas en aluminio bloqueadas mediante expansión mecánica de los tubos.

Intercambiador lado agua

Del tipo con placas (AISI 316), se encuentra aislado mediante material con cámaras cerradas, para reducir las dispersiones térmicas. **Provisto, de serie, de la resistencia eléctrica anticongelante.**

Separador de líquido (sólo para bomba de calor)

Colocado en aspiración al compresor, para la protección de posibles retornos de refrigerante líquido, comienzos inundados y funcionamiento con existencia de líquido.

Válvula termostática

La válvula de tipo mecánico, con ecualizador externo situado a la salida del evaporador, regula el flujo de gas al evaporador en función de la carga térmica para asegurar un grado correcto de sobrecalentamiento al gas en aspiración.

Filtro deshidratador

De tipo mecánico, realizado en cerámica y material higroscópico, capaz de retener las impurezas y las posibles huellas de humedad existentes en el circuito de refrigeración.

Indicador del líquido

Sirve para verificar la carga de gas refrigerante y la posible existencia de humedad en el circuito de refrigeración.

Válvula solenoide

La válvula se cierra cuando se apaga el compresor impidiendo el flujo de gas refrigerante hacia el evaporador.

Grifos del líquido

Permiten interceptar el refrigerante en caso de mantenimiento extraordinario.

Válvula de inversión del ciclo (sólo para bomba de calor)

Invierte el flujo de refrigerante al cambiar el funcionamiento verano / invierno y durante los ciclos de descongelación.

Válvulas de seguridad circuito de refrigeración

Calibrada a 30 Bar; interviene descargando la sobrepresión en caso de presiones anómalas.

Válvula unidireccional

Permite el paso del refrigerante en una sola dirección. Está presente sólo en los modelos con bomba de calor y recuperación total.

Acumulación del líquido

sólo para bombas de calor o con recuperación total.

Se emplea en los modelos con bomba de calor o con recuperación total. Sirve para detener el gas refrigerante en estado líquido, en caso de que durante su funcionamiento la máquina en objeto lo presente de forma abundante.

3.2 BASTIDOR Y VENTILADORES

Estructura portante

De lámina de acero galvanizada en calor de espesor adecuado, está lacada con polvos de poliéster capaz de resistir los agentes atmosféricos a lo largo del tiempo.

Grupo de ventilación

De tipo centrífugo, balanceados estática y dinámicamente, están conectados al cigüeñal mediante polea regulable. El motor del ventilador está protegido con interruptor magnetotérmico. En la parte superior de la estructura están fijadas rejillas anti-intrusión. En la versión silenciada L el grupo de ventilación es modificado para limitar su ruido.

Seccionador su jetapuerta

Se puede acceder al cuadro eléctrico si se quita tensión mediante la palanca de apertura del propio cuadro. Durante las intervenciones de mantenimiento es posible bloquear dicha palanca con uno o más candados, para impedir una indeseada puesta en funcionamiento de la máquina.

3.3 COMPONENTES HIDRÁULICOS

Presostato diferencial

Está montado entre la entrada y la salida del intercambiador y, en caso de caudal de agua demasiado bajo, detiene el compresor. Está presente sólo en los modelos sin acumulación y/o bomba.

Flujostato

Cumple la función de controlar que exista circulación de agua, en caso contrario, bloquea la unidad. Está presente sólo en las versiones con acumulación y/o bomba.

Bomba de circulación

Ofrece, en función de las características de la bomba elegida, una prevalencia útil para vencer las pérdidas de carga de la instalación. Se contempla además la posibilidad de una bomba de reserva.⁽²⁾

Filtro agua

Montado de serie en las versiones con acumulación, permite bloquear y eliminar eventuales impurezas de los circuitos hidráulicos. En su interior presenta una malla filtrante con orificios que no superan el milímetro. Es indispensable para evitar graves daños al intercambiador con placas.

En las versiones sin acumulación y/o bomba es suministrado en dotación. Su instalación es obligatoria bajo pena de caducidad de la garantía.

Depósito de acumulación⁽¹⁾

È in acciaio e la capienza è di 500 litri (per le taglie 0800-0900-1000 la capienza è di 700 litri). Con el objeto de reducir las dispersiones térmicas y eliminar el fenómeno de la formación de condensación, se aísla mediante material poliuretánico de idóneo espesor. Monta, de serie, una resistencia eléctrica anticongelante (hasta -20 °C de temperatura externa - temperatura del agua del tanque de 5 °C) accionada por la sonda anticongelante insertada en el tanque.⁽³⁾

Válvula de ventilación

Es de acero y la capacidad es de 500 litros (para las medidas 0800-0900-1000 la capacidad es de 700 litros. De tipo automático, descarga posibles bolsas de aire presentes. Se encuentra interceptada por un grifo para facilitar su posible sustitución. Está presente tanto en la versión con acumulación como en la versión con grupo bombas.

Grupo de llenado

Está dotado de manómetro para la visualización de la presión de la instalación. No está presente en las versiones con acumulación y/o bomba.

Vaso de expansión

Es del tipo de membrana con precarga de azoto. Está presente tanto en la versión con acumulación como en la versión con grupo bombas.

NOTE

(1) =Componente del circuito hidráulico existente sólo en las unidades con acumulación.

(2) = La bomba de reserva es controlada por el tarjeta electrónica. Las bombas instaladas pueden ser de baja o de alta prevalencia

(3) = NEn las versiones bombas de calor se prevé la posibilidad de tener la preinstalación para varias resistencias integradas; **Cuya adquisición, montaje y conexión será a cargo del usuario. Se recuerda además, que tales orificios de preinstalación poseen tapones provisionales de plástico. En caso de que al principio no se coloquen las resistencias eléctricas con los cierres correspondientes, los tapones de plástico deben sustituirse por otros de metal.**

Válvula de seguridad circuito hidráulico

Calibrada a 6 bar y con la descarga canalizable interviene descargando la sobrepresión en caso de presiones anómalas. No está presente en las versiones con acumulación y/o bomba.

3.4 COMPONENTES DE SEGURIDAD Y DE CONTROL

Teclado de mando

Permite el completo control del equipo. Para una descripción más detallada, haga referencia al manual de uso.

Tablero mandos a distancia (suministrado de serie)

Permite realizar a distancia las siguientes operaciones:

- encendido y apagado de la unidad ON / OFF (indicación mediante el testigo amarillo);
- Selección del tipo de funcionamiento frío/ calor (indicación mediante el testigo verde/rojo);
- Reactivación alarmas mediante el encendido de un indicador rojo.

En caso de indicación de una alarma, es posible poner a cero el tablero remoto, con el interruptor ON / OFF. La unidad y el tablero de mandos están unidos con un cable de 6 polos, con una sección de 0,5 mm² (máx. 50 m), 1 mm² (máx. 100 m).

Resistencia eléctrica antihielo (instalada

de serie)

Su funcionamiento es accionado por la sonda anticongelante colocada en el evaporador con placas. La activación tiene lugar cuando la temperatura del agua es +3°C mientras su desactivación se verifica con temperatura del agua de +5°C. El software dedicado, residente en la tarjeta de regulación, controla la resistencia eléctrica.

Presostato de alta presión (instalado de serie)

Con calibrado variable, situado en el lado de alta presión del circuito de refrigeración, detiene el funcionamiento del compresor en el caso de presiones anómalas de trabajo.

Presostato de baja presión (3)

Con calibrado fijo, se encuentra en el lado de baja presión del circuito frigorífico y detiene el funcionamiento del compresor en caso de presiones de funcionamiento anómalas.

NOTA

(3) = No está presente en las versiones de bomba de calor.

- magnetotérmico protección compresores;
- magnetotérmico protección ventiladores;
- magnetotérmico protección auxiliar;
- resistencia cárter compresores;
- **transductores de baja presión TP1: de serie en las bombas de calor.**
- **transductor de alta presión TP2: de serie en las bombas de calor, en los modelos sólo frío de serie sólo en los modelos 0500 - 0550 - 0600 - 0650 - 0700 - 0750 - 0800 - 0900 - 1000.**
- Termostato control temperatura gas de descarga

3.5 COMPONENTES ELÉCTRICOS

Cuadro eléctrico

Contiene la sección de potencia y la gestión de los controles y seguridades. Está de acuerdo con las normas CEI 60204-1, y con las Directivas respecto a la compatibilidad electromagnética EMC 89/336/CEE y 92/31/CEE.

3.6 REGULACIÓN ELECTRÓNICA

Tarjeta de microprocesador

Compuesta de tarjeta de gestión y control y de tarjeta de visualización. Funciones que lleva a cabo:

- Tab/>regulación temperatura agua entrada evaporador con termostato de hasta 4 niveles y control propor-

- cional - integral en la velocidad de los ventiladores.
- retraso de puesta en marcha com • memoria permanente de las alarmas.
- autostart después de una caída de la tensión.
- mensajería multilingüe.
- funcionamiento con control local o remoto.
- visualización estado de la máquina: ON/OFF compresores; resumen alarmas.
- control alarmas:

- alta presión;
- flujostato presostato diferencial
- baja presión;
- anticongelante;
- sobrecarga compresores;
- sobrecarga ventiladores;
- sobrecarga bombas.
- visualización de los siguientes parámetros:
- temperatura entrada agua;
- temperatura entrada agua evaporador;
- temperatura salida agua; delta T;

- alta presión; baja presión;
- tiempo espera de arranque.
- visualización de alarmas.
- configuraciones set:
- a) sin contraseña: set frío; diferencial total;
- b) con contraseña: set anticongelante; tiempo exclusión baja presión; lenguaje display; código de acceso.

NOTE

Para ulteriores informaciones, ver el manual del usuario.

4 ACCESORIOS

DR 200/400 - Dispositivo para bajas temperaturas

Este accesorio sólo está disponible para las versiones con bomba de calor. Permite un funcionamiento correcto en enfriamiento con temperaturas externas inferiores a 19 °C y hasta -10 °C. Está compuesto por una compuerta que, asociada al transductor de alta presión TP (de serie en la máquina) y basándose en la presión de condensación, modula el caudal de aire al condensador para mantener la presión a un valor suficientemente alto.

DR 202/402 - Dispositivo para bajas temperaturas

Este accesorio sólo está disponible para las versiones sólo frío. Permite un funcionamiento correcto en enfriamiento con temperaturas externas inferiores a 19 °C y hasta -10 °C. Está compuesto por una compuerta que, asociada a los dos transductores de alta presión TP (comprendido en el kit) y basándose en la presión de condensación, modula el caudal de aire para mantener la presión a un valor suficientemente alto.

PGS - Programador diario / semanal.

Pequeña ficha a insertar en la tarjeta electrónica de la unidad. Permite programar dos franjas horarias al día y tener programaciones diferenciadas para cada día de la semana.

ROMEO - Remote Overwaching Modem Enabling Operation.

El dispositivo ROMEO (Remote Overwaching Modem Enabling Operation) permite el control remoto de la enfriadora desde un común teléfono móvil dotado de programa de navegación WAP, así como el envío de SMS de alarma o pre-alarma a 3 teléfonos móviles GSM, incluso si no están dotados de programa de navegación WAP. En el kit está incluido el AER485.

TP1 Transductor baja presión (de serie en los modelos con bomba de calor)

Permite visualizar en el display de la tarjeta con microprocesador al valor de la presión de aspiración del compresor (uno por circuito). Colocado en el lado de baja presión del circuito frigorífico, detiene el funcionamiento del compresor en caso de presiones de trabajo anómalas.

TP 2 - Transductor de alta presión

De serie en los tamaños 0500, 0550, 0600, 0650, 0700, 0750, 0800, 0900, 1000 y en todos los modelos con bomba de calor. Permite visualizar en el display de la tarjeta con microprocesador al valor de la presión de impulsión del compresor (uno por circuito). Colocado en el lado de alta presión del circuito frigorífico, detiene el funcionamiento del compresor en caso de presiones de trabajo anómalas.

VT - Soportes antivibradores

Grupo de cuatro antivibradores para montar debajo de la base de chapa de la unidad, en los puntos ya predispuestos, los cuales sirven para atenuar las vibraciones producidas durante el funcionamiento por el grupo de ventilación y los compresores.

AVX - Soporte antivibración

Soportes antivibración de muelle. Seleccione el modelo AVX en la tabla de compatibilidades.

AER485 -Tarjeta para sistema MODBUS

Este accesorio permite la conexión de la unidad con sistemas de supervisión BMS con estándar eléctrico RS 485 y protocolo de tipo MODBUS.

DRE - Dispositivo de reducción corriente de arranque. Permite la reducción de la corriente de arranque necesaria durante la puesta en marcha de la máquina. Accesorio que se aplica en fábrica.

RIF - Correctores de desfase

Corrector de desfase de corriente: conectado en paralelo al motor, permite una reducción de la corriente absorbida. Debe solicitarse en el pedido. Accesorio que se aplica en fábrica.

Dualchiller - Sistema de control simplificado para el mando, encendido y apagado de dos enfriadoras, con mando Aermec GR3, en una misma instalación como si fuesen una sola unidad.

Multichiller - Sistema de control para el mando, encendido y apagado de enfriadoras individuales en una instalación en la que se han ubicado varios aparatos en paralelo asegurando siempre el caudal constante en los evaporadores.

TABLA DE COMPATIBILIDAD DE LOS ACCESORIOS

	0275	0300	0325	0350	0500	0550	0600	0650	0700	0750	0800	0900	1000
AER485	•	•	•	•	•	•	•	•	•	•	•	•	•
DUALCHILLER	•	•	•	•	•	•	•	•	•	•	•	•	•
MULTICHILLER	•	•	•	•	•	•	•	•	•	•	•	•	•
AVX 401							•	•					
AVX 402							• (*)	• (*)	•	•			
AVX 403									• (*)	• (*)			
AVX 404											•	•	
AVX 405													•
AVX 406											• (*)	• (*)	
AVX 407													• (*)
DR200	• (**)	• (**)	• (**)										
DR400				• (**)	• (**)	• (**)							
DR202	•	•	•										
DR402				•									
DR600							•	•	•	•			
DR800											•	•	•
DRE275	•												
DRE300		•											
DRE325			•	•									
DRE 10					• (x2)	•	• (x2)						
DRE 15					•	• (x2)	• (x2)	• (x4)	• (x4)	• (x2)			
DRE 25										• (x2)	• (x4)	• (x2)	
DRE 30												• (x2)	• (x4)
PGS	•	•	•	•	•	•	•	•	•	•	•	•	•
RIF 62	•	•	•										
RIF 82				•									
RIF 63					•	•							
RIF 64							•	•	•	•	•		
RIF 74												•	
RIF 84													•
ROMEO	•	•	•	•	•	•	•	•	•	•	•	•	•
TP1	• (x2) ***	• (x2) ***	• (x2) ***	• (x2) ***	• (x2) ***	• (x2) ***	• (x2) ***	• (x2) ***	• (x2) ***	• (x2) ***	• (x2) ***	• (x2) ***	• (x2) ***
TP2	• (X2) ***	• (X2) ***	• (X2) ***	• (X2) ***									
VT14 *				•	•	•							
VT16 *	•	•	•										
VT17					•	•							
VT2	•	•	•	•									

DR = accesorio obligatorio en las versiones D.

(*) = a usarse en las versiones con acumulación.

(**) = a usarse en las versiones con bomba de calor.

(***) = De serie en las versiones con bomba de calor.

Los números entre paréntesis indican la cantidad necesaria.

N.B.: Se recuerda que las versiones sólo bomba, montan los mismos soportes antivibradores de la versión base.

5 DATOS TÉCNICOS

5.1 CONDICIONES NOMINALES DE REFERENCIA

Los datos técnicos se calculan:

Durante el enfriamiento

- Temperatura agua en entrada	12 °C
- Temperatura agua en salida	7 °C
- Temperatura aire externo	35 °C
- Δt	5 °C

Durante el calentamiento

- Temperatura agua en salida	50 °C
- Temperatura aire externo	b.s. 7 °C
	b.u. 6 °C
- Δt	5 °C

Potencia sonora

Aermec determina el valor de la potencia sonora en base a las medidas efectuadas de acuerdo con la normativa 9614, en conformidad con lo requerido por la certificación Eurovent.

[1] Presión sonora

Presión sonora en campo libre sobre plano reflectante (factor de direccionalidad Q=2), a 10 m de distancia de la superficie externa de la unidad, con el método del paralelo expandido (box-method, ISO 3744)

NOTA

- Los datos del ruido se refieren a la configuración sin bomba.
- Para las bombas de calor el dato se refiere al funcionamiento durante el enfriamiento.

E.S.E.E.R.

La atención hacia los consumos eléctricos de las máquinas para el acondicionamiento es cada vez más importante también en Europa. En Estados Unidos, desde hace muchos años, no se hace referencia a la sola eficiencia en condiciones de proyecto, sino que se utiliza un índice de evaluación que toma en cuenta el marginal funcionamiento de la unidad en condiciones de proyecto y el mayor uso con cargas parciales, con aire externo inferior al de proyecto y en condiciones de parcialización de los compresores. En Europa se ha adoptado la propuesta.

EECCAC (Energy Efficiency and Certification of Central Air Conditioner) y ESEER (European Seasonal Energy Efficiency Ratio), para poder comparar las enfriadoras entre sí. Después de haber calculado la energía total requerida por la instalación durante la gestión estival (kWh), se pueden deducir los consumos de energía eléctrica de la temporada con esta fórmula:

$$\text{Energía absorbida} = \frac{\text{Energía requerida}}{\text{Índice de eficiencia}}$$

El cálculo energético real puede obtenerse más correctamente considerando:

1. Perfil de carga con temperatura externa
2. Perfil climático
3. Total de horas

Con estos datos cada asesor o proyectista puede realizar sus propias evaluaciones.

$$\text{ESEER} = (3 \times \text{EER}100\% + 33 \times \text{EER}75\% + 41 \times \text{EER}50\% + 23 \times \text{EER}25\%) / 100$$

Evaporador salida del agua				7 °C
ΔT cargado completamente				5 °C
Cargo	100%	75%	50%	25%
Aire externo de la temperatura	35 °C	30 °C	25 °C	20 °C

5.2 DATOS TÉCNICOS VERSIONES ESTÁNDAR (°)

NRC°		0275	0300	0325	0350	0500	0550
Potencia de refrigeración	kW	51,0	59,0	67,0	76,0	89,0	97,0
Potencia absorbida total	kW	22,0	26,1	29,4	32,3	37,6	40,4
Caudal agua evaporador	l/h	8770	10150	11520	13070	15310	16680
Pérdida carga evaporador	kPa	37,0	32,2	31,6	43,0	27,6	22,4
INDICES ENERGÉTICOS							
EER	W/W	2,32	2,26	2,28	2,35	2,37	2,40
ESEER	W/W	2,59	2,53	2,55	2,63	2,74	2,78
DATOS ELÉCTRICOS							
Alimentación	V	3N~400 V 50 HZ (versiones 0275 - 0750), 3~400 V 50Hz (versiones 0800 - 1000)					
Corriente absorbida total	A	40,3	46,5	51,3	57,5	68,1	72,1
Corriente máxima	A	54	63	71	80	93	99
Corriente de arranque	A	153	161	165	208	219	223
COMPRESORES							
Tipo		scroll	scroll	scroll	scroll	scroll	scroll
Número	n°	2	2	2	2	3	3
Número por circuito	n°+n°+n°+n°	2/2	2/2	2/2	2/2	3/2	3/2
RESISTENCIA COMPRESORES							
Resistencia cárter compresores	n°xW	2x75	2x75	2x75	2x75	3x75	3x75
VENTILADORES							
Tipo		centrifugo	centrifugo	centrifugo	centrifugo	centrifugo	centrifugo
Número	n°	2	2	2	2	2	2
Corriente absorbida gr. ventilación	A	4,5	7,8	8,5	5,8	7,3	7,3
Potencia absorbida gr. ventilación	kW	2,4	4,0	4,0	4,0	4,6	4,6
Caudal aire	m3/h	16000	22000	22000	26000	27000	27000
EVAPORADORES							
Tipo		placas	placas	placas	placas	placas	placas
Número	n°	1	1	1	1	1	1
CIRCUITO HIDRÁULICO							
Acumulador de agua	lt	500	500	500	500	500	500
Resistencia antihielo acumulador	W	300	300	300	300	300	300
GRUPO BOMBEO BAJA PREVALENCIA							
Potencia absorbida	kW	0,75	0,75	0,75	0,75	1,10	1,10
Corriente absorbida	A	1,85	1,85	1,85	1,85	2,14	2,14
Presión útil	kPa	127	127	122	104	131	126
GRUPO BOMBEO ALTA PREVALENCIA							
Potencia absorbida	kW	1,10	1,10	1,50	1,50	1,85	1,85
Corriente absorbida	A	2,14	2,14	2,92	2,92	3,60	3,60
Presión útil	kPa	178	173	168	154	195	193
DATOS SONOROS							
Potencia sonora	dB(A)	85	85	85,5	88,5	88	88
Presión sonora [1]	dB(A)	53	53	54	56	56	56
DIMENSIONES versión básica (sin acumulación ni bomba)							
Altura	mm	1763	1793	1793	1763	1963	1963
Longitud	mm	2100	2100	2100	2450	2450	2450
Longitud	mm	950	950	950	950	950	950
PESO en vacío sin acumulador ni bombas							
	kg	629	665	699	777	904	919

NOTA: Para las conexiones hidráulicas, consultar el manual de instalación.

NRC°		0600	0650	0700	0750	0800	0900	1000
Potencia de refrigeración	kW	120	136	156	184	214	238	264
Potencia absorbida total	kW	52,0	58,0	65,5	77,0	90,0	100,0	112,5
Caudal agua evaporador	l/h	20.640	23.390	26.830	31.650	36.810	40.940	45.410
Pérdida carga evaporador	kPa	32,0	28,3	36,5	27,8	35,6	30,3	30,6
INDICES ENERGÉTICOS								
EER	W/W	2,31	2,34	2,38	2,39	2,38	2,38	2,35
ESEER	W/W	3,0	3,05	3,0	3,11	3,19	3,19	3,19
DATOS ELÉCTRICOS								
Alimentación	V	3N~400 V 50 HZ (versiones 0275 - 0750), 3~400 V 50Hz (versiones 0800 - 1000)						
Corriente absorbida total	A	93,4	101,5	117,0	134,5	153,7	171,7	193,2
Corriente máxima	A	131	143	164	190	225	245	277
Corriente de arranque	A	207	215	267	318	337	404	424
COMPRESORES								
Tipo		scroll	scroll	scroll	scroll	scroll	scroll	scroll
Número	n°	4	4	4	4	4	4	4
Número por circuito	n°+n°+n°+n°	4/2	4/2	4/2	4/2	4/2	4/2	4/2
RESISTENCIA COMPRESORES								
Resistencia cárter compresores	n°xW	4 x 75	4 x 75	4 x 75	2x75 2x130	4 x 130	4 x 130	4 x 130
VENTILADORES								
Tipo		centrifugo	centrifugo	centrifugo	centrifugo	centrifugo	centrifugo	centrifugo
Número	n°	3	3	3	3	4	4	4
Corriente absorbida gr. ventilación	A	17,4	17,4	18,5	21,9	27,1	31,7	38,0
Potencia absorbida gr. ventilación	kW	9,9	9,9	10,5	12,45	15,4	18	21,6
Caudal aire	m3/h	45.000	45.000	50.000	50.000	60.000	68.000	68.000
EVAPORADORES								
Tipo		placas	placas	placas	placas	placas	placas	placas
Número	n°	1	1	1	1	1	1	1
CIRCUITO HIDRÁULICO								
Acumulador de agua	lt	500	500	500	500	700	700	700
Resistencia antihielo acumulador	W	300	300	300	2x300	2x300	3x300	2x300
GRUPO BOMBEO BAJA PREVALENCIA								
Potencia absorbida	kW	1,1	1,5	1,85	1,85	3	3	3
Corriente absorbida	A	2,14	2,92	3,6	3,6	6,2	6,2	6,2
Presión útil	kPa	69	85	103	100	97	95	82
GRUPO BOMBEO ALTA PREVALENCIA								
Potencia absorbida	kW	3,7	3,7	3,7	3,7	5,5	5,5	5,5
Corriente absorbida	A	7,21	7,21	7,21	7,21	11	11	11
Presión útil	kPa	177	163	146	166	215	212	195
DATOS SONOROS								
Potencia sonora	dB(A)	90	90	91	91	92	92,5	92,5
Presión sonora (1)	dB(A)	58,0	58,0	59,0	59,0	60,0	60,0	60,0
DIMENSIONES versión básica (sin acumulación ni bomba)								
Altura	mm	2288	2288	2288	2288	2295	2295	2295
Longitud	mm	3750	3750	4550	4550	4950	4950	4950
Longitud	mm	1100	1100	1100	1100	1300	1300	1300
PESO en vacío sin acumulador ni bombas								
	kg	1481	1498	1737	1918	2670	2700	2960

NOTA: Para las conexiones hidráulicas, consultar el manual de instalación.

5.3 DATOS TÉCNICOS VERSIONES SILENCIADAS (L)

NRC L		0275	0300	0325	0350	0500	0550
Potencia de refrigeración	kW	46,0	54,0	62,0	70,0	81,0	89,0
Potencia absorbida total	kW	22,7	26,3	29,7	33,1	40,0	43,0
Caudal agua evaporador	l/h	7910	9290	10660	12040	13930	15310
Pérdida carga evaporador	kPa	30,3	27,0	27,1	36,5	22,6	19,0
INDICES ENERGÉTICOS							
EER	W/W	2,03	2,05	2,09	2,11	2,03	2,07
ESSER	W/W	2,06	2,19	2,22	2,25	2,24	2,28
DATOS ELÉCTRICOS							
Alimentación	V	3N~400 V 50 HZ (versiones 0275 - 0750), 3~400 V 50Hz (versiones 0800 - 1000)					
Corriente absorbida total	A	40,5	45,8	50,7	57,7	68,7	73,3
Corriente máxima	A	54	63	71	80	93	99
Corriente de arranque	A	152	158	163	206	217	221
COMPRESORES							
Tipo		scroll	scroll	scroll	scroll	scroll	scroll
Número	n°	2	2	2	2	3	3
Número por circuito	n°+n°+n°+n°	2/2	2/2	2/2	2/2	3/2	3/2
RESISTENCIA COMPRESORES							
Resistencia cárter compresores	n°xW	2x75	2x75	2x75	2x75	3x75	3x75
VENTILADORES							
Tipo		centrifugo	centrifugo	centrifugo	centrifugo	centrifugo	centrifugo
Número	n°	2	2	2	2	2	2
Corriente absorbida gr. ventilación	A	2,4	4,1	4,2	3,2	3,9	3,9
Potencia absorbida gr. ventilación	kW	1,4	2,4	2,5	1,9	2,3	2,3
Caudal aire	m ³ /h	11000	15500	15500	18000	19000	19000
EVAPORADORES							
Tipo		placas	placas	placas	placas	placas	placas
Número	n°	1	1	1	1	1	1
CIRCUITO HIDRÁULICO							
Acumulador de agua	lt	500	500	500	500	500	500
Resistencia antihielo acumulador	W	300	300	300	300	300	300
GRUPO BOMBEO BAJA PREVALENCIA							
Potencia absorbida	kW	0,75	0,75	0,75	0,75	1,10	1,10
Corriente absorbida	A	1,85	1,85	1,85	1,85	2,14	2,14
Presión útil	kPa	142	138	131	119	149	143
GRUPO BOMBEO ALTA PREVALENCIA							
Potencia absorbida	kW	1,10	1,10	1,50	1,50	1,85	1,85
Corriente absorbida	A	2,14	2,14	2,92	2,92	3,60	3,60
Presión útil	kPa	186	180	176	164	203	203
DATOS SONOROS							
Potencia sonora	dB(A)	81	81	82	84	84	84
Presión sonora (1)	dB(A)	49,0	49,0	50,0	52,0	52,0	52,0
DIMENSIONES versión básica (sin acumulación ni bomba)							
Altura	mm	1763	1793	1793	1763	1963	1963
Longitud	mm	2100	2100	2100	2450	2450	2450
Longitud	mm	950	950	950	950	950	950
PESO en vacío sin acumulador ni bombas							
		638	674	708	786	917,5	932,5

NOTA: Para las conexiones hidráulicas, consultar el manual de instalación.

NRC L		0600	0650	0700	0750	0800	0900	1000
Potencia de refrigeración	kW	110	126	142	168	194	216	238
Potencia absorbida total	kW	47,5	54,0	62,0	72,5	83,0	94,0	104,5
Caudal agua evaporador	l/h	18.920	21.670	24.420	28.900	33.370	37.150	40.940
Pérdida carga evaporador	kPa	27,2	24,2	30,5	23,2	29,6	25,0	25,0
INDICES ENERGÉTICOS								
EER	W/W	2,32	2,33	2,29	2,32	2,34	2,30	2,28
ESSER	W/W	2,90	2,88	2,84	2,89	2,98	2,93	2,95
DATOS ELÉCTRICOS								
Alimentación	V	3N~400 V 50 HZ (versiones 0275 - 0750), 3~400 V 50Hz (versiones 0800 - 1000)						
Corriente absorbida total	A	82,8	91,9	107,5	122,8	138,1	155,8	173,4
Corriente máxima	A	131	143	164	190	225	245	277
Corriente de arranque	A	205	212	266	315	334	401	419
COMPRESORES								
Tipo		scroll	scroll	scroll	scroll	scroll	scroll	scroll
Número	n°	4	4	4	4	4	4	4
Número por circuito	n°+n°+n°+n°	4/2	4/2	4/2	4/2	4/2	4/2	4/2
RESISTENCIA COMPRESORES								
Resistencia cárter compresores	n°xW	4 x 75	4 x 75	4 x 75	2x75 2x130	4 x 130	4 x 130	4 x 130
VENTILADORES								
Tipo		centrifugo	centrifugo	centrifugo	centrifugo	centrifugo	centrifugo	centrifugo
Número	n°	3	3	3	3	4	4	4
Corriente absorbida gr. ventilación	A	14,3	14,3	15,8	18,0	20,4	26,1	33,1
Potencia absorbida gr. ventilación	kW	8,1	8,1	9	10,2	11,6	14,8	18,8
Caudal aire	m3/h	31.500	31.500	35.000	35.000	42.000	47.600	47.600
EVAPORADORES								
Tipo		placas	placas	placas	placas	placas	placas	placas
Número	n°	1	1	1	1	1	1	1
CIRCUITO HIDRÁULICO								
Acumulador de agua	lt	500	500	500	500	700	700	700
Resistencia antihielo acumulador	W	300	300	300	2x300	2x300	3x300	2x300
GRUPO BOMBEO BAJA PREVALENCIA								
Potencia absorbida	kW	1,1	1,5	1,85	1,85	3	3	3
Corriente absorbida	A	2,14	2,92	3,6	3,6	6,2	6,2	6,2
Presión útil	kPA	82	93	117	118	120	116	102
GRUPO BOMBEO ALTA PREVALENCIA								
Potencia absorbida	kW	3,7	3,7	3,7	3,7	5,5	5,5	5,5
Corriente absorbida	A	7,21	7,21	7,21	7,21	11	11	11
Presión útil	kPA	183	168	154	164	210	207	185
DATOS SONOROS								
Potencia sonora	dB(A)	86	86	87	87	88	88,5	88,5
Presión sonora [1]	dB(A)	54,0	54,0	55,0	55,0	56,0	56,5	56,5
DIMENSIONES versión básica (sin acumulación ni bomba)								
Altura	mm	2288	2288	2288	2288	2295	2295	2295
Longitud	mm	3750	3750	4550	4550	4950	4950	4950
Longitud	mm	1100	1100	1100	1100	1300	1300	1300
PESO en vacío sin acumulador ni bombas								
	kg	1481	1498	1737	1918	2670	2700	2960

* = para las conexiones de las versiones 01/08 consultar el manual de instalación.

5.4 DATOS TÉCNICOS VERSIONES BOMBA DE CALOR H

NRC H		0275	0300	0325	0350	0500	0550
Potencia de refrigeración	kW	49	57	65	74	86	94
Potencia absorbida total	kW	21,6	25,6	28,8	31,7	36,9	39,6
Caudal agua evaporador	l/h	8.430	9.800	11.180	12.730	14.790	16.170
Pérdida carga evaporador	kPa	34,2	30,3	32,5	42,2	25,4	20,7
INDICES ENERGÉTICOS							
EER	W/W	2,27	2,23	2,26	2,33	2,33	2,37
COP	W/W	2,32	2,27	2,33	2,40	2,38	2,43
ESEER		2,54	2,49	2,53	2,61	2,7	2,75
FUNCIONAMIENTO EN CALOR							
Potencia térmica	kW	58	67	77	87	101	111
Potencia absorbida total	kW	25,0	29,5	33,0	36,2	42,5	45,7
Caudal agua evaporador	l/h	9.980	11.520	13.248	14.960	17.370	19.090
Pérdida carga evaporador	kPa	42,0	36,8	40,9	51,7	32,2	26,5
DATOS ELÉCTRICOS							
Alimentación	V	3N~400 V 50 HZ (versiones 0275 - 0750), 3~400 V 50Hz (versiones 0800 - 1000)					
Corriente absorbida total S.F	A	39,7	45,8	50,5	56,7	67,1	71,0
Corriente absorbida total P.d.C	A	44,0	50,7	56,1	62,7	74,4	78,9
Corriente máxima	A	54	63	71	80	93	99
Corriente de arranque	A	155	162	168	210	222	227
COMPRESORES							
Tipo		scroll	scroll	scroll	scroll	scroll	scroll
Número	n°	2	2	2	2	3	3
Número por circuito	n°+n°+n°+n°	2/2	2/2	2/2	2/2	3/2	3/2
RESISTENCIA COMPRESORES							
Resistencia cárter compresores	n°xW	2x75	2x75	2x75	2x75	3x75	3x75
VENTILADORES							
Tipo		centrifugo	centrifugo	centrifugo	centrifugo	centrifugo	centrifugo
Número	n°	2	2	2	2	2	2
Corriente absorbida gr. ventilación	A	4,5	7,8	8,5	5,8	7,3	7,3
Potencia absorbida gr. ventilación	kW	2,7	4,6	5,0	3,4	4,3	4,3
Caudal aire	m ³ /h	16.000	22.000	22.000	26.000	27.000	27.000
EVAPORADORES							
Tipo		placas	placas	placas	placas	placas	placas
Número	n°	1	1	1	1	1	1
CIRCUITO HIDRÁULICO							
Acumulador de agua	lt	500	500	500	500	500	500
Resistencia antihielo acumulador	W	300	300	300	300	300	300
GRUPO BOMBEO BAJA PREVALENCIA							
Potencia absorbida	kW	0,75	0,75	0,75	0,75	1,1	1,1
Corriente absorbida	A	1,85	1,85	1,85	1,85	2,14	2,14
Presión útil	kPa	137	134	126	108	146	132
GRUPO BOMBEO ALTA PREVALENCIA							
Potencia absorbida	kW	1,10	1,10	1,50	1,50	1,85	1,85
Corriente absorbida	A	2,14	2,14	2,92	2,92	3,60	3,60
Presión útil	kPa	180	176	170	157	196	196
DATOS SONOROS							
Potencia sonora	dB(A)	84,9	84,9	85,6	88,4	88,2	88,3
Presión sonora (1)	dB(A)	53	53	54	56	56	56
DIMENSIONES versión básica (sin acumulación ni bomba)							
Altura	mm	1763	1793	1793	1763	1963	1963
Longitud	mm	2100	2100	2100	2450	2450	2450
Longitud	mm	950	950	950	950	950	950
PESO en vacío sin acumulador ni bombas							
	kg	689	737	748	841	983	999

NOTA: Para las conexiones hidráulicas, consultar el manual de instalación.

NRC H		0600	0650	0700	0750	0800	0900	1000
Potencia de refrigeración	kW	118	134	152	178	204	230	254
Potencia absorbida total	kW	51,0	56,5	64,0	76,0	89,5	100,0	112,0
Caudal agua evaporador	l/h	20.300	23.050	26.140	30.620	35.090	39.560	43.690
Pérdida carga evaporador	kPa	30,5	27,0	34,8	26,0	32,8	28,0	28,3
INDICES ENERGÉTICOS								
EER	W/W	2,31	2,37	2,38	2,34	2,28	2,30	2,27
COP	W/W	2,37	2,44	2,45	2,48	2,48	2,47	2,47
ESEER		3,1	3,09	3,09	3,05	3,06	3,08	3,04
FUNCIONAMIENTO EN CALOR								
Potencia térmica	kW	136	155	175	207	239	267	295
Potencia absorbida total	kW	57,5	63,5	71,5	83,5	96,5	108,0	119,5
Caudal agua evaporador	l/h	23.390	26.660	30.100	35.600	41.110	45.920	50.740
Pérdida carga evaporador	kPa	39,9	40,0	41,0	31,0	45,2	42,2	44,9
DATOS ELÉCTRICOS								
Alimentación	V	3N~400 V 50 Hz (versiones 0275 - 0750), 3~400 V 50Hz (versiones 0800 - 1000)						
Corriente absorbida total S.F	A	92,0	99,8	115,3	133,5	153,7	172,7	192,9
Corriente absorbida total P.d.C	A	101,9	110,9	127,4	145,8	166,2	186,5	206,9
Corriente máxima	A	131	143	164	190	225	245	277
Corriente de arranque	A	213	223	275	326	346	414	435
COMPRESORES								
Tipo		scroll	scroll	scroll	scroll	scroll	scroll	scroll
Número	n°	4	4	4	4	4	4	4
Número por circuito	n°+n°+n°+n°	4/2	4/2	4/2	4/2	4/2	4/2	4/2
RESISTENCIA COMPRESORES								
Resistencia cárter compresores	W	4x75	4x75	4x75	2x75 2x130	4x130	4x130	4x130
VENTILADORES								
Tipo		centrifugo	centrifugo	centrifugo	centrifugo	centrifugo	centrifugo	centrifugo
Número	n°	3	3	3	3	4	4	4
Corriente absorbida gr. ventilación	A	17,4	17,4	18,6	21,9	27,2	32	38
Potencia absorbida gr. ventilación	kW	9,9	9,9	10,5	12,45	15,4	18	21,6
Caudal aire	m3/h	45.000	45.000	50.000	50.000	60.000	68.000	68.000
EVAPORADORES								
Tipo		placas	placas	placas	placas	placas	placas	placas
Número	n°	1	1	1	1	1	1	1
CIRCUITO HIDRÁULICO								
Acumulador de agua	lt	500	500	500	500	700	700	700
Resistencia antihielo acumulador	n°xW	300	300	300	2x300	2x300	2x300	2x300
GRUPO BOMBEO BAJA PREVALENCIA								
Potencia absorbida	kW	3,7	3,7	3,7	3,7	3	3	3
Corriente absorbida	A	7,21	7,21	7,21	7,21	6,22	6,22	6,22
Presión útil	kPa	60	100	117	116	105	102	88
GRUPO BOMBEO ALTA PREVALENCIA								
Potencia absorbida	kW	3,7	3,7	3,7	3,7	5,5	5,5	5,5
Corriente absorbida	A	7,21	7,21	7,21	7,21	11	11	11
Presión útil	kPa	177	160	142	162	225	222	204
DATOS SONOROS								
Potencia sonora	dB(A)	90	90	91	91	92	92,5	92,5
Presión sonora (1)	dB(A)	58	58	59	59	60	60	60
DIMENSIONES versión básica (sin acumulación ni bomba)								
Altura	mm	2288	2288	2288	2288	2295	2295	2295
Longitud	mm	3750	3750	4550	4550	4950	4950	4950
Longitud	mm	1100	1100	1100	1100	1300	1300	1300
PESO en vacío sin acumulador ni bombas								
	kg	1593	1610	1831	2001	2797	2827	3095

NOTA: Para las conexiones hidráulicas, consultar el manual de instalación.

6 CRITERIOS DE ELECCIÓN

En su configuración estándar, los aparatos no son adecuados para una instalación en ambiente salino. Los límites máximos y mínimos para los flujos de agua en el intercambiador se encuentran indicados por las curvas de los diagramas de las pérdidas de carga. Para los límites de funcionamiento, consulte los diagramas

de abajo, válidos para $\Delta t = 5^\circ\text{C}$.

ATENCIÓN:

- El funcionamiento con temperatura del agua producida inferior a 4°C está permitido sólo para las versiones específicamente previstas (versión Y).
- Si se desea que la máquina funcione fuera de los límites indicados en el

diagrama, contacte la oficina técnica comercial AERMEC.

6.1 LÍMITES DE FUNCIONAMIENTO

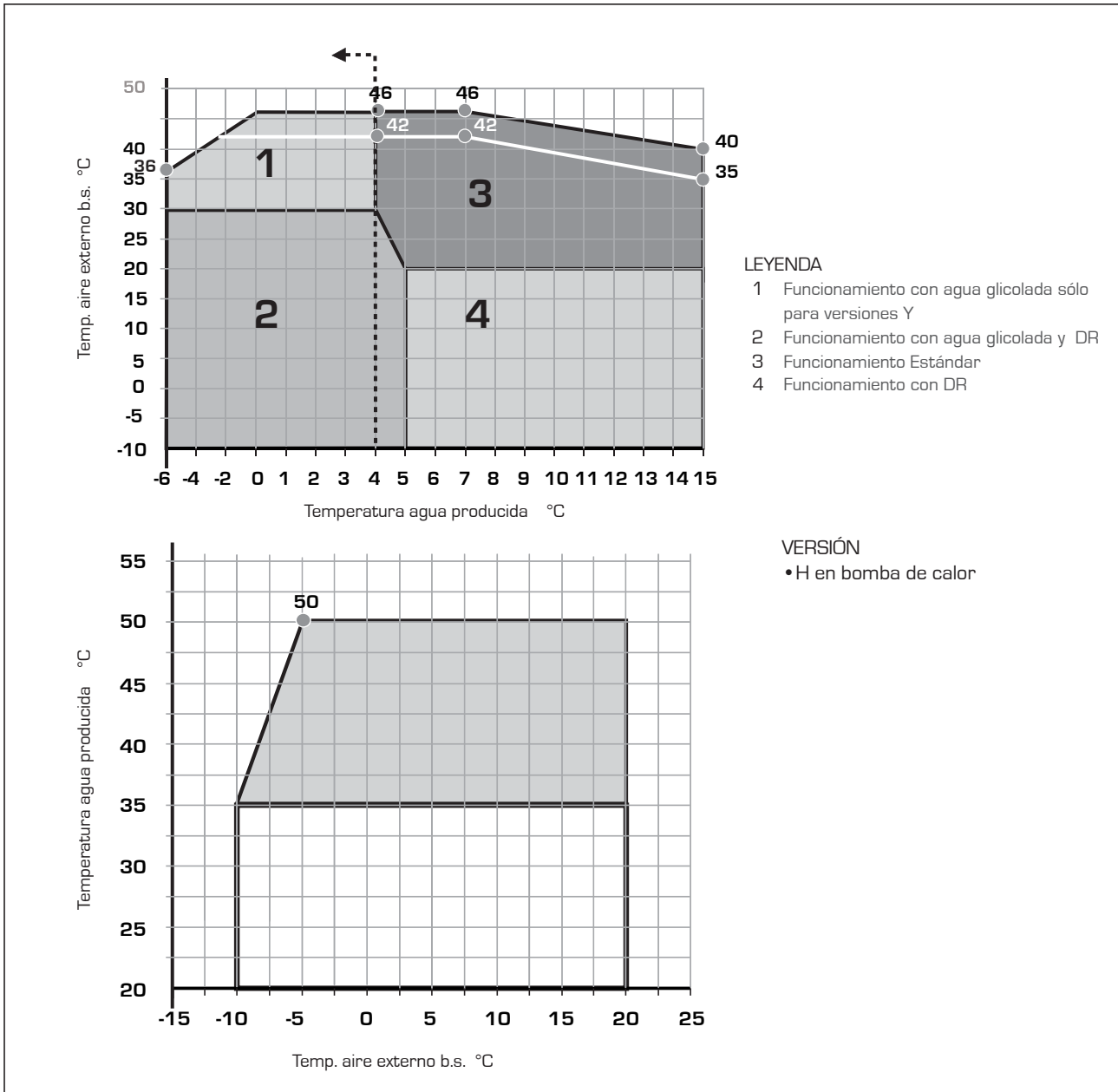

6.2 DATOS DE PROYECTO

(1) = Sólo para las versiones de bomba de calor

		Lado alta presión	Lado baja presión
Presión máxima admisible	bar	30 / 28 (1)	22
Temperatura máxima admisible	$^\circ\text{C}$	120	52
Temperatura mínima admisible	$^\circ\text{C}$	-10	-16 / -10 (1)

7 COEFICIENTES CORRECTIVOS

7.1 POTENCIA DE REFRIGERACIÓN Y ABSORBIDA

- "VERSIONES ESTÁNDAR"

- "VERSIONES BOMBA DE CALOR EN FUNCIONAMIENTO EN FRÍO"

La potencia de refrigeración creada y la potencia absorbida en condiciones distintas de las nominales se obtienen multiplicando los valores nominales (Pf, Pa) por los respectivos coeficientes correctivos (Cf, Ca).

Los siguientes diagramas permiten obtener los coeficientes correctivos a utilizar para los aparatos, en los varios modelos, durante el funcionamiento en frío; con cada curva se encuentra correspondientemente indicada la temperatura del aire externo a la cual se refiere.

LEYENDA:

Cf = Coeficiente correctivo de la potencia de refrigeración

Ca = Coeficiente correctivo de la potencia absorbida

NOTA:

PARA LAS VERSIONES Y Con temperaturas inferiores a los 4 °C contacte la sede

PARA ΔT DIFERENTES DE 5°C

Use en el evaporador la Tab.7.4 para obtener los factores correctivos de la potencia de refrigeración y absorbida. Para controlar el ensuciamiento de los intercambiadores se utilizan los correspondientes factores de ensuciamiento

7.2 POTENCIA DE REFRIGERACIÓN Y ABSORBIDA

- "VERSIONES SILENCIADAS"

La potencia de refrigeración creada y la potencia absorbida en condiciones distintas de las nominales se obtienen multiplicando los valores nominales (Pf, Pa) por los respectivos coeficientes correctivos (Cf, Ca).

Los siguientes diagramas permiten obtener los coeficientes correctivos a utilizar para los aparatos, en los varios modelos, durante el funcionamiento en frío; con cada curva se encuentra correspondientemente indicada la temperatura del aire externo a la cual se refiere.

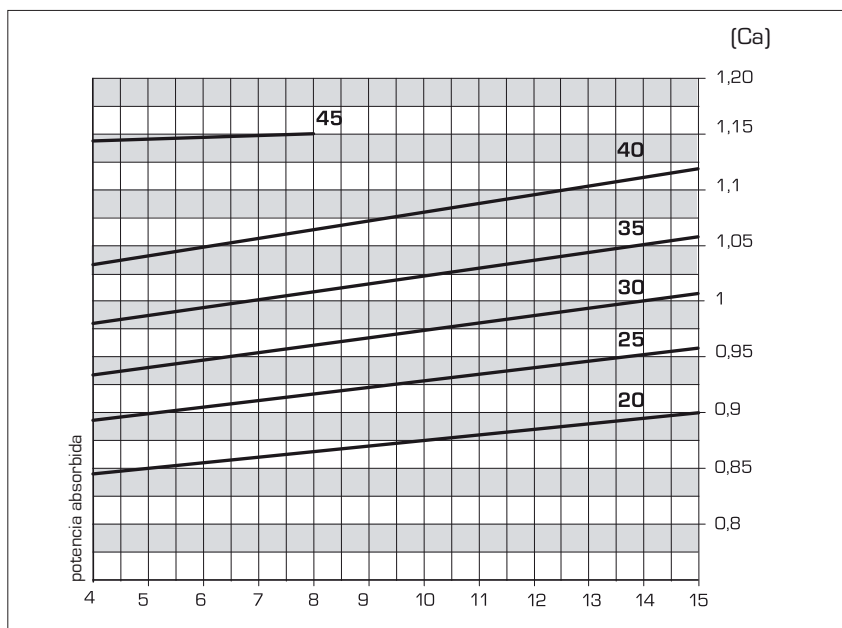
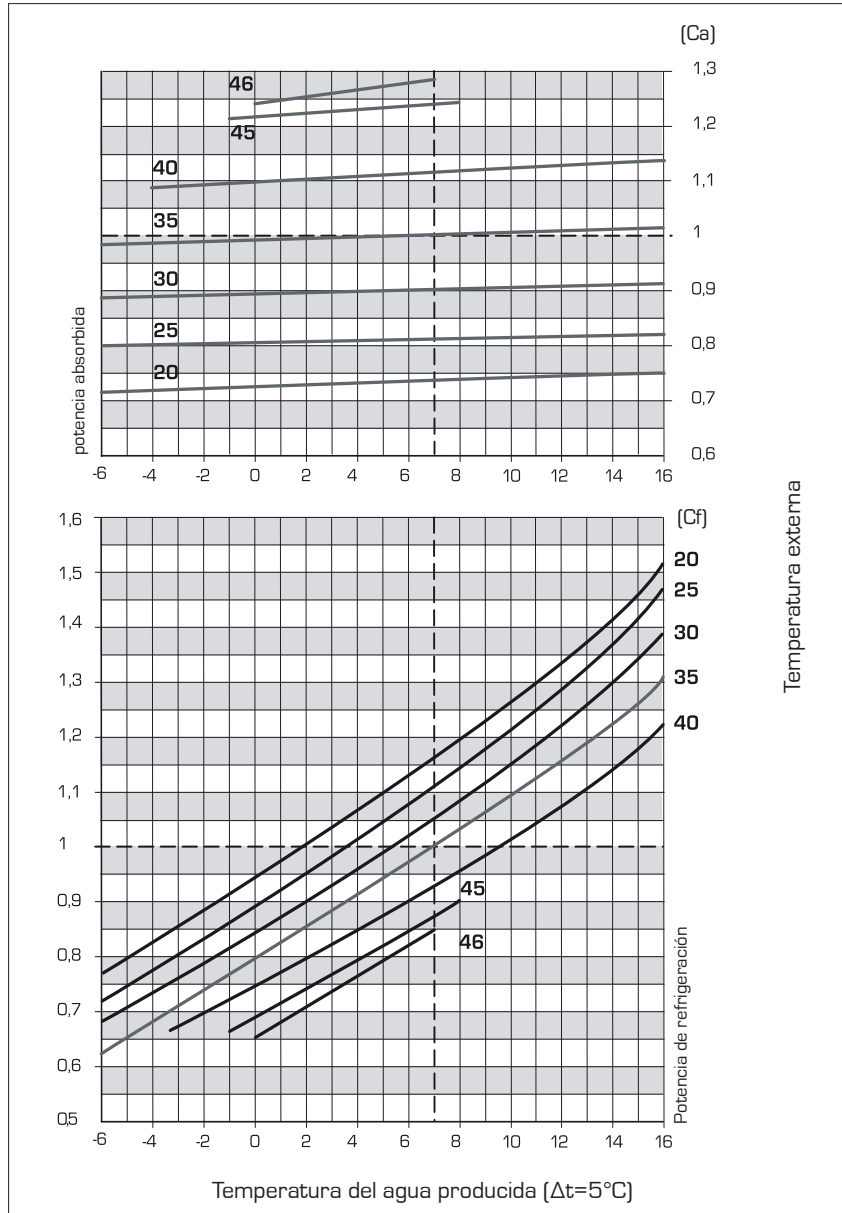

LEYENDA:

Cf = Coeficiente correctivo de la potencia de refrigeración

Ca = Coeficiente correctivo de la potencia absorbida

NOTA:

- PARA LAS VERSIONES Y con temperaturas inferiores a los 4 °C póngase en contacto con la sede

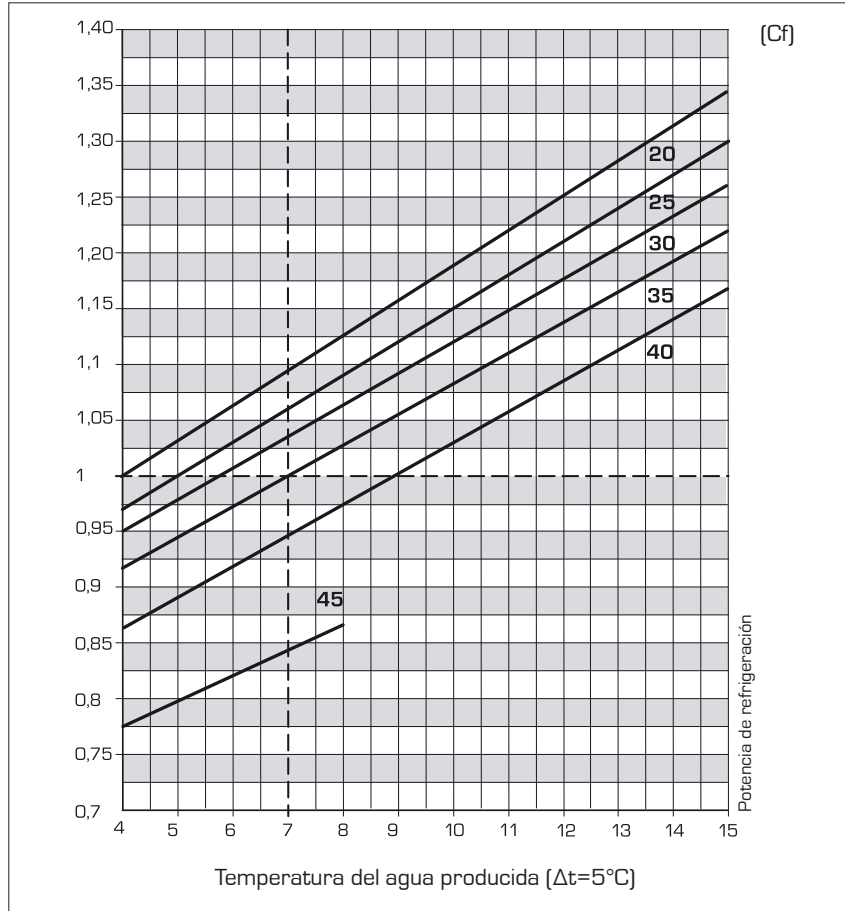

7.3 POTENCIA TÉRMICA Y ABSORBIDA

- "VERSIONES BOMBA DE CALOR"

La potencia térmica producida y la potencia eléctrica absorbida en condiciones diversas de las nominales se obtienen multiplicando los valores nominales (Pf, Pa) que aparecen al pie de la página por los respectivos coeficientes correctivos (Cf, Ca). El siguiente diagrama permite obtener los coeficientes correctivos; en relación con cada curva se indica la temperatura del agua caliente producida a la que se hace referencia, asumiendo una diferencia de temperatura del agua entre entrada y salida del condensador igual a 5°C.

Los rendimientos son en neto de los ciclos de descongelación.

LEYENDA:

Ct = Coeficiente correctivo de la potencia térmica

Ca = Coeficiente correctivo de la potencia absorbida

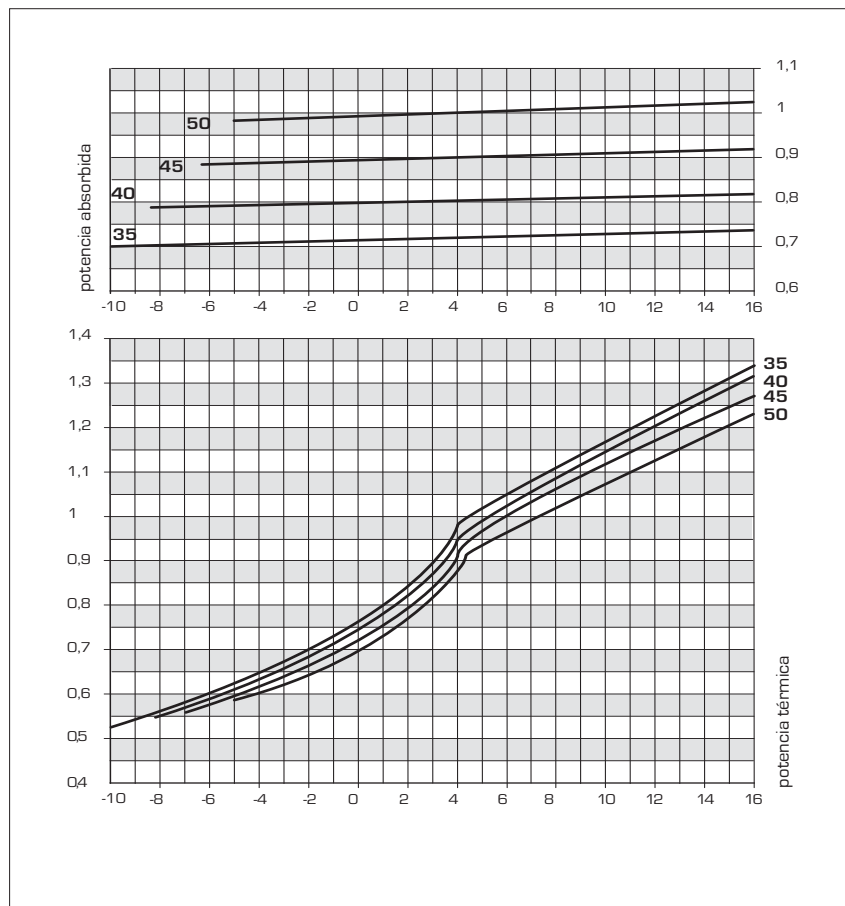

7.4 PARA ΔT DIFERENTES DEL NOMINAL

Para Δt diferentes de 5°C en el evaporador, use la Tab.1 para obtener los factores correctivos de la potencia de refrigeración y absorbida. Para controlar el ensuciamiento de los intercambiadores se utilizan los correspondientes factores de ensuciamiento

7.5 FACTORES DE INCRUSTACIÓN

Las prestaciones indicadas en la tabla se refieren a las condiciones de tubos limpios con factor de incrustación = 1. Para valores diferentes del factor de incrustación multiplique los datos de las tablas de prestaciones por los coeficientes indicados.

7.4.1 Factores correctivos para Δt diferentes del nominal Chiller

	3	5	8	10
Factores de corrección potencia de refrigeración	0,99	1	1,02	1,03
Factores de corrección potencia absorbida	0,99	1	1,01	1,02

7.5.1 Factores de incrustación

	[K*m ²]/[W]	0,00005	0,0001	0,0002
Factor de cor. potencia de refrigeración		1	0,98	0,94
Factores de corrección potencia absorbida		1	0,98	0,95

8 SOLUCIÓN DE GLICOL ETILÉNICO

Los factores de corrección de potencia de refrigeración y absorbida tienen en cuenta la presencia de glicol y la diferente temperatura de evaporación.

Los factores de corrección del caudal del agua y de las pérdidas de carga deben aplicarse directamente a los datos obtenidos para el funcionamiento sin glicol. El factor de corrección del caudal del agua se calcula con el objetivo de mantener el mismo Δt que se tendría sin glicol.

- El factor de corrección de la pérdida de carga ya tiene en cuenta el diferente caudal que se deriva de la aplicación del factor de corrección del caudal del agua.
- Los factores de corrección del caudal del agua y de las pérdidas de carga deben aplicarse directamente a los datos obtenidos para el funcionamiento sin glicol.
- Los factores de corrección de la potencia de refrigeración y absorbida

tienen en cuenta la presencia de glicol.

- Los factores de corrección del caudal del agua y de las pérdidas de carga deben aplicarse directamente a los datos obtenidos para el funcionamiento sin glicol.
- El factor de corrección del caudal del agua se calcula con el objetivo de mantener el mismo Δt que se tendría sin glicol.
- El factor de corrección de la pérdida de carga ya tiene en cuenta el diferente caudal que se deriva de la aplicación del factor de corrección del caudal del agua.

Notas

Para facilitar la lectura del gráfico, en la página siguiente se muestra un ejemplo.

Utilizando el siguiente diagrama es posible establecer el porcentaje de glicol necesario; dicho porcentaje es calculable tomando en consideración uno de los siguientes factores:

En función al fluido considerado (agua o aire), se debe acceder al gráfico por

la parte derecha o izquierda, por la intersección de las redes temperatura externa o temperatura agua producida y las curvas correspondientes, se obtiene un punto a través del cual debe pasar la línea vertical que representa tanto el porcentaje de glicol como los coeficientes correctivos correspondientes.

8.1 CÓMO LEER LAS CURVAS DEL GLICOL

Las curvas presentadas en la figura resumen una notable cantidad de datos, cada un de los cuales está representado por una específica curva, para poder utilizar de forma correcta estas curvas es necesario hacer algunas consideraciones iniciales:

- Si se desea calcular el porcentaje de glicol en base a la temperatura exterior, se deberá entrar desde el eje izquierdo y una vez intersecada la curva debe trazarse una línea vertical que interceptará a su vez las otras curvas; Los puntos obtenidos de las

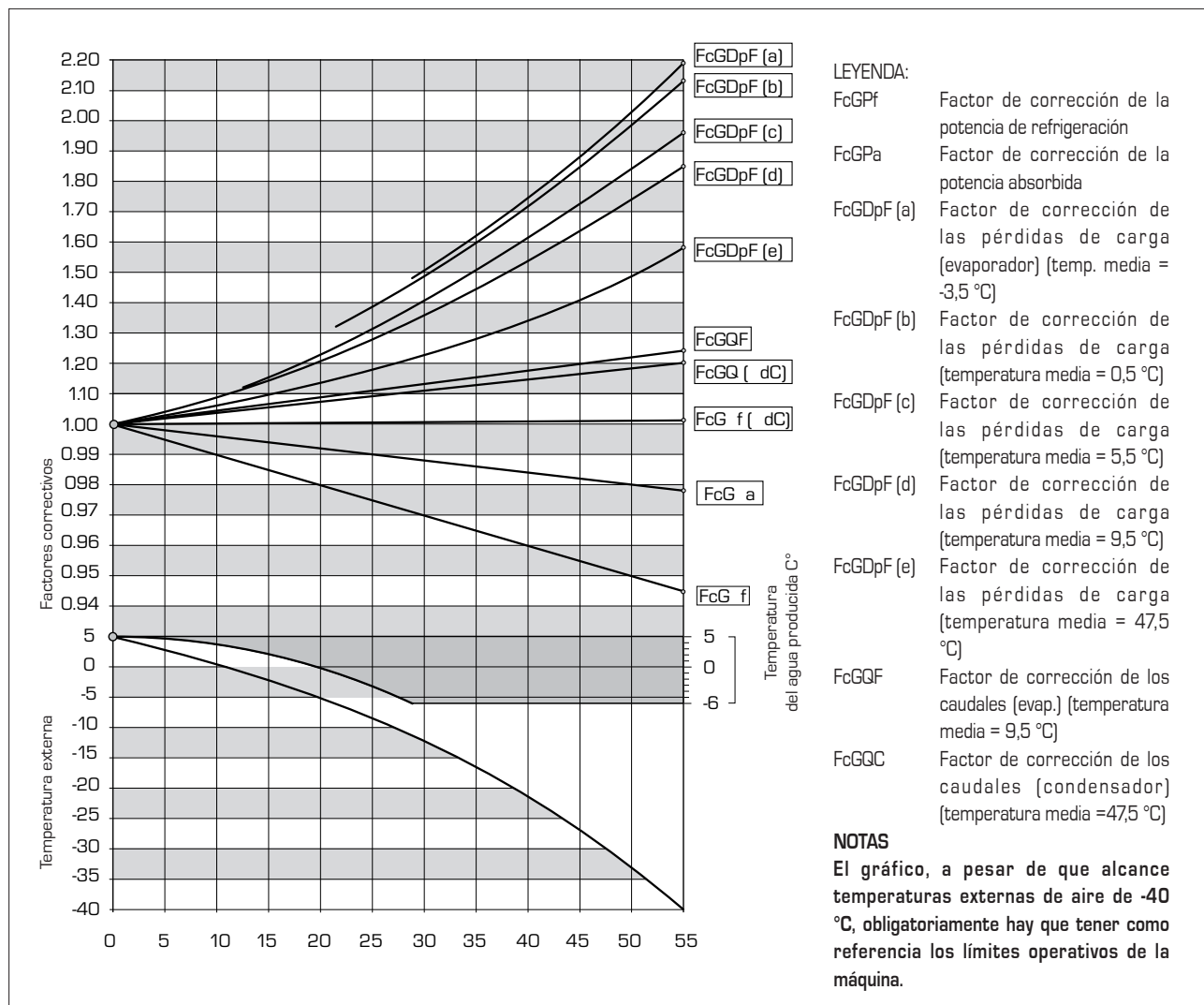

curvas superiores representan los coeficientes para la corrección de la potencia de refrigeración y absorbida, para los envíos y las pérdidas de carga (se recuerda que dichos coeficientes se deben multiplicar por el valor nominal del tamaño en consideración); mientras que el eje inferior aconseja el valor porcentual de glicol necesario en función a la temperatura del aire externo considerado.

- Si se desea calcular el porcentaje de glicol en base a la temperatura del

agua producida, se deberá entrar desde el eje derecho y una vez intersecada la curva debe trazarse una línea vertical que interceptará a su vez las otras curvas; Los puntos obtenidos de las curvas superiores representan los coeficientes para la potencia de refrigeración y absorbida, para los envíos y las pérdidas de carga (se recuerda que dichos coeficientes se deben multiplicar por el valor nominal del tamaño en consideración); mientras que el eje inferior aconseja

el valor porcentual de glicol necesario para producir agua a la temperatura deseada.

Recordamos que los tamaños iniciales "TEMPERATURAS EXTERIORES" y "TEMPERATURA AGUA PRODUCIDA", no están directamente relacionados entre sí, así que no es posible entrar en la curva de uno de estos tamaños y obtener el correspondiente punto en otra curva.

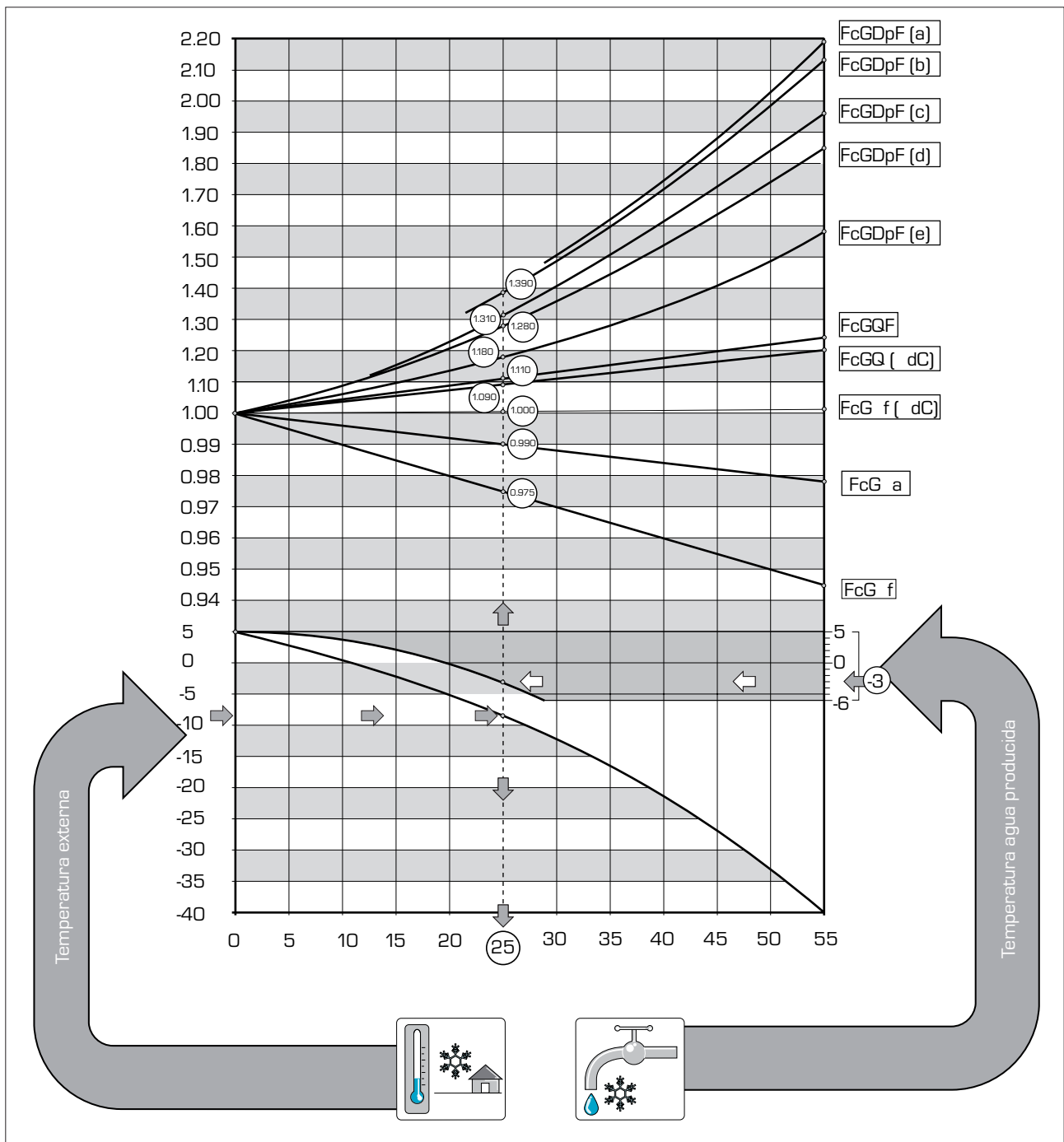

9 PÉRDIDAS DE CARGA

9.1 PÉRDIDAS DE CARGA EVAPORADOR

Los gráficos siguientes ilustran los valores de las pérdidas de carga en kPa en función del caudal en m³/h.

El campo de funcionamiento está delimitado por el valor mínimo y máximo de las curvas, que indican los límites de uso de los intercambiadores lado agua (evaporadores). Las pérdidas de carga de los

diagramas se refieren a una temperatura media del agua de 10 °C. La siguiente tabla presenta la corrección que se debe aplicar a las pérdidas de carga a medida que cambia la temperatura media del agua

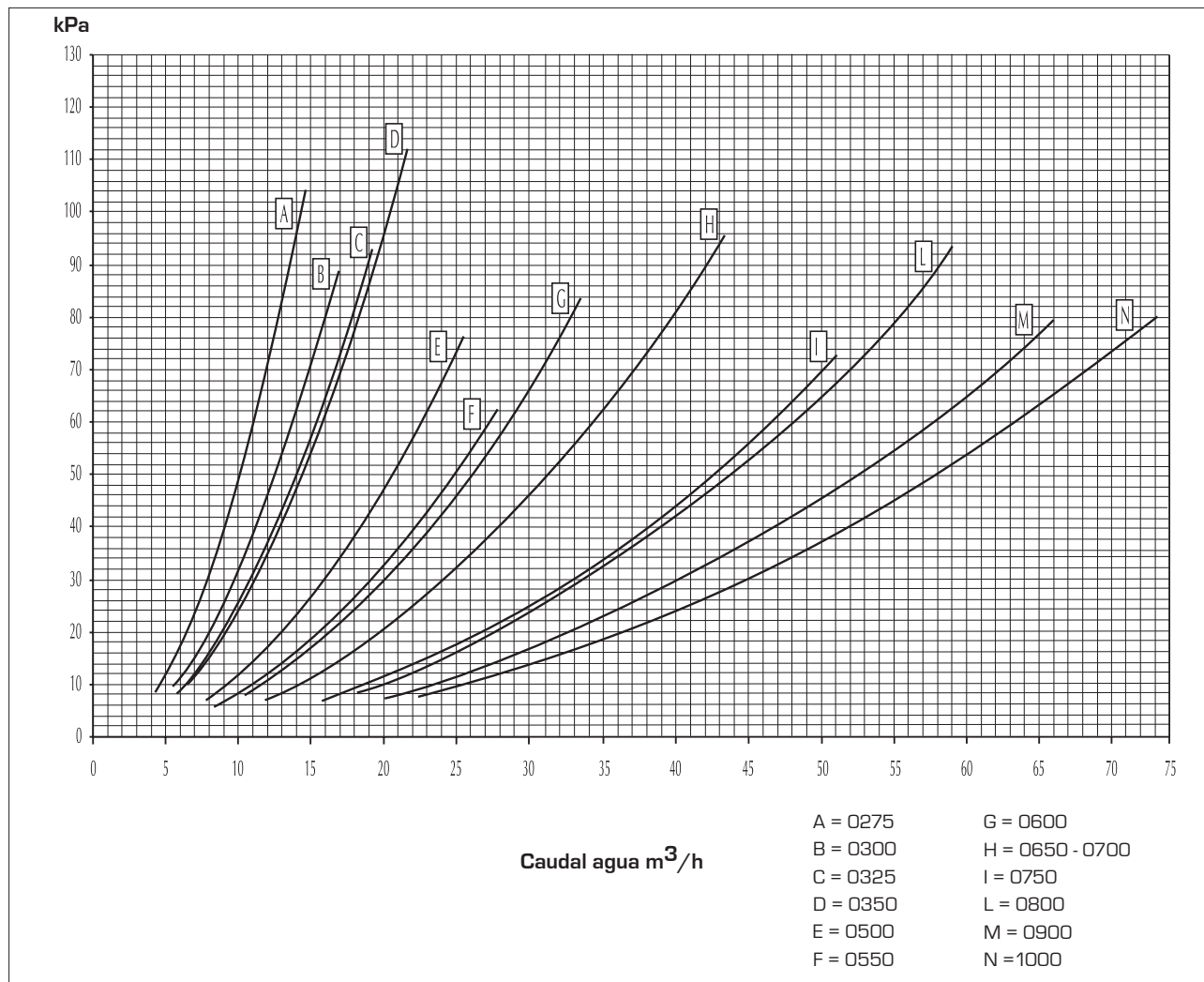

9.1.1 COEFICIENTE PARA DATOS DIFERENTES DE LOS NOMINALES

Temperatura media agua °C	5°C	10°C	15°C	20°C	30°C	40°C	50°C
Coefficiente multiplicativo	1,02	1	0,985	0,97	0,95	0,93	0,91

Para valores de temperatura diferentes del nominal, remitirse a la tabla 9.1.1 para obtener los coeficientes.

9.2 PÉRDIDAS DE CARGA FILTRO AGUA

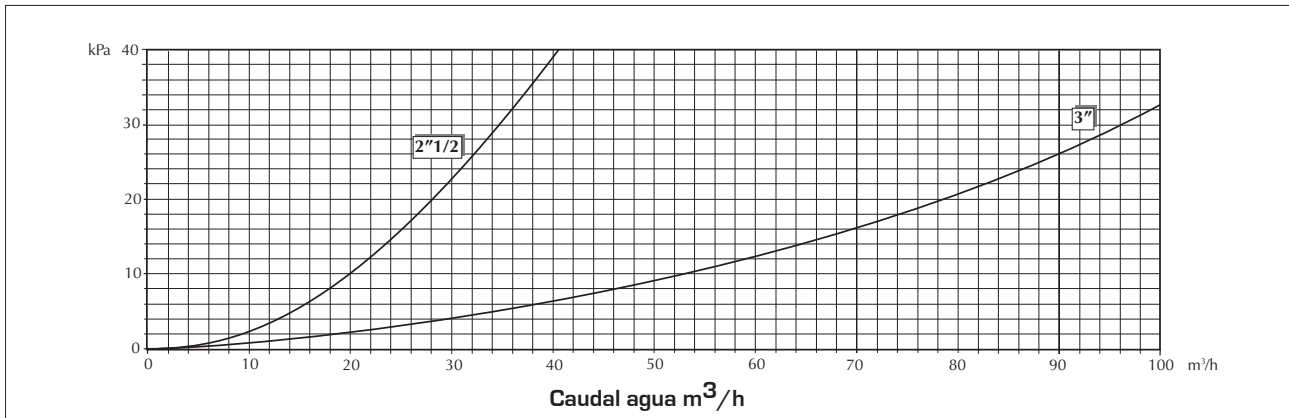

Modelo	Ø	Modelo	Ø
0275	2" 1/2	0650	2" 1/2
0300	2" 1/2	0700	2" 1/2
0325	2" 1/2	0750	2" 1/2
0350	2" 1/2	0800	3"
0500	2" 1/2	0900	3"
0550	2" 1/2	1000	3"
0600	2" 1/2		

9.3 CARACTERÍSTICAS DE LOS FILTROS

MODELOS	CARACTERÍSTICAS
0275 - 0300 - 0325 - 0350 - 0500 - 0550 - 0600 0650 - 0700 - 0750	Ø gas : 2" 1/2 Ø orificio trazado: 600 micron número orificios por cm ² : 53
0275 - 0300 - 0325 - 0350 - 0500 - 0550 - 0600 0650 - 0700 - 0750	con desrecaentador de recuperación parcial Filtro del circuito del desrecaentador: Ø gas: 1" 1/2 Ø orificio trazado: 500 micron número orificios por cm ² : 80 Filtro circuito hidráulico: Ø gas: 2" 1/2 Ø orificio trazado: 600 micron número orificios por cm ² : 53
0275 - 0300 - 0325 - 0350 - 0500 - 0550 - 0600 0650 - 0700 - 0750	con desrecaentador de recuperación total Filtro en la recuperación total: Ø gas: 2" 1/2 Ø foro inscritto: 600 micron numero fori per cmq: 53 Filtro circuito idraulico: Ø gas: 2" 1/2 Ø orificio trazado: 600 micron número orificios por cm ² : 53
0800 - 0900 - 1000	Ø nominal: 80 mm Ø orificio trazado: 1600 micron número orificios por cm ² : 22
0800 - 0900 - 1000	con desrecaentador de recuperación total Filtro en la recuperación total Ø nominal: 80 mm Ø orificio trazado: 1600 micron número orificios por cm ² : 22 Filtro circuito hidráulico Ø nominal: 80 mm Ø orificio trazado: 1600 micron número orificios por cm ² : 22

10 ACUMULACIÓN

Los modelos con acumulación prevén diversas preparaciones que varían en base altura útil de descarga que se desea obtener, con las características del grupo de bombeo y la existencia o no de orificios para resistencia integrativa.

En las siguientes tablas se evidencian las características principales de los componentes del circuito hidráulico, mientras que los gráficos de estas páginas indican las correspondientes prevalencias. Los tanques de acumulación con orificios para resistencia eléctrica se encuentran provistos de tapones de plástico de cierre provisorio.

ATENCIÓN

Antes de la puesta en marcha el encargado de la instalación deberá proceder al montaje de las resistencias eléctricas. Si tales resistencias no fueran necesarias de inmediato, los tapones en plástico deberán ser sustituidos con oportunos tapones de metal.

10.1 CONTENIDO MÁXIMO DE AGUA DE LA INSTALACIÓN

En la tabla que sigue se encuentra indicado el contenido máximo en litros de agua de la instalación hidráulica, compatible con la capacidad del recipiente de expansión suministrado de serie. Los valores que aparecen en la tabla se refieren a tres condiciones de temperatura máxima y mínima del agua. Si el contenido de agua efectivo de la instalación hidráulica (incluso el tanque de acumulación) es superior al que resulta en la tabla con las condiciones operativas, se deberá instalar un ulterior vaso de expansión adicional, dimensionado, utilizando los habituales criterios relacionados con el volumen de agua adicional.

Mediante las siguientes tablas se pueden obtener los valores de contenido máximo de la instalación, también para otras condiciones de funcionamiento con agua glicolada.

Los valores se obtienen multiplicando el valor de referencia por el coeficiente de corrección.

10.1.1 CALIBRADO VASO DE EXPANSIÓN

El valor estándar de presión de precarga de los dos vasos de expansión es igual a 1,5 bar, mientras que su volumen es de 24 litros, **valor máximo 6 bar**.

El calibrado del depósito se debe regular de acuerdo con el desnivel máximo (H) de la unidad (véase figura) según la fórmula:

Altura hidráulica	H m	30	25	20	15	10
Calibrado del vaso de expansión	bar	3,2	2,8	2,3	1,8	standard
Valor de referencia contenido agua	l ⁽¹⁾	1087	1323	1559	1795	1926
Valor de referencia contenido agua	l ⁽²⁾	489	595	702	808	866
Valor de referencia contenido agua	l ⁽³⁾	255	311	366	422	452

Agua glicolada	Temp. agua °C		Coeficiente de corrección	Condición de referencia
	max.	min.		
10%	40	-2	0,507	(1)
10%	60	-2	0,686	(2)
10%	85	-2	0,809	(3)
20%	40	-6	0,434	(1)
20%	60	-6	0,604	(2)
20%	85	-6	0,729	(3)
35%	40	-6	0,393	(1)
35%	60	-6	0,555	(2)
35%	85	-6	0,677	(3)

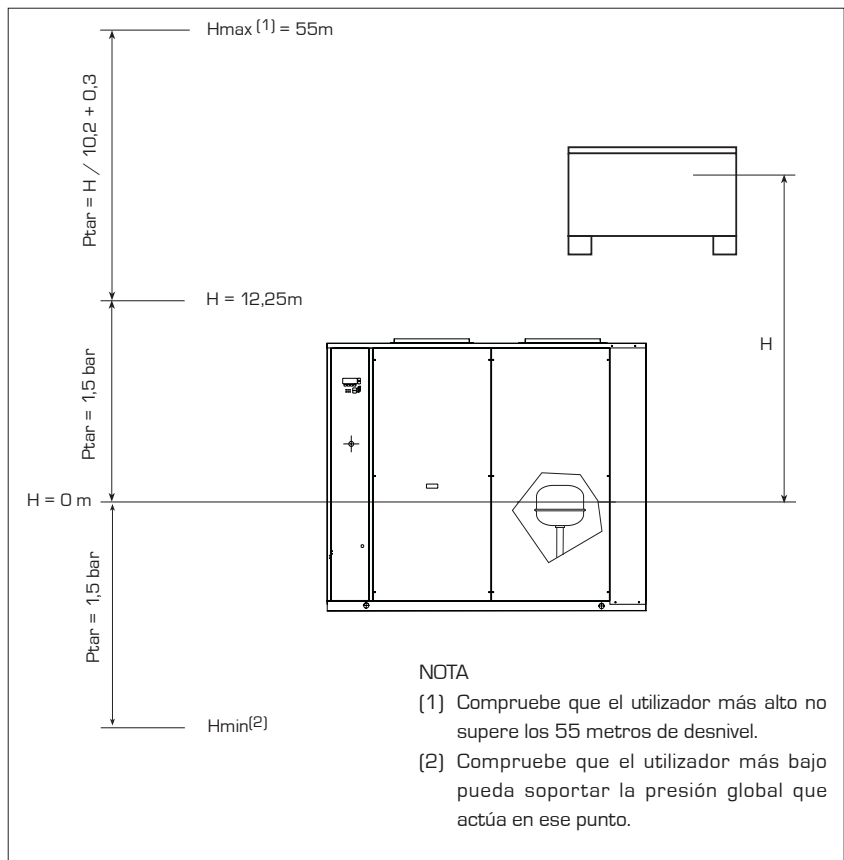

$$p \text{ [calibrado] [bar]} = H \text{ [m]} / 10,2 + 0,3.$$

Por ejemplo, si el valor del desnivel H es igual a 20 m, el valor del calibrado del depósito será de 2,3 bar.

Si el valor del ajuste obtenido por el cálculo resultase inferior a 1,5 bar (es decir, para H < 12,25), mantener el ajuste estándar.

11 PREVALENCIAS ÚTILES PARA LA INSTALACIÓN

Las prevalencias aquí indicadas son al neto de las pérdidas de carga de los intercambiadores, filtro y tubo de conexión. Por tanto, deben considerarse útiles para la instalación.

ATENCIÓN

Ya que las bombas pueden ser de alta o baja prevalencia, presentamos aquí dos gráficos distintos para no causar incompreensión en la selección.

11.1 BOMBAS BAJA PREVALENCIA

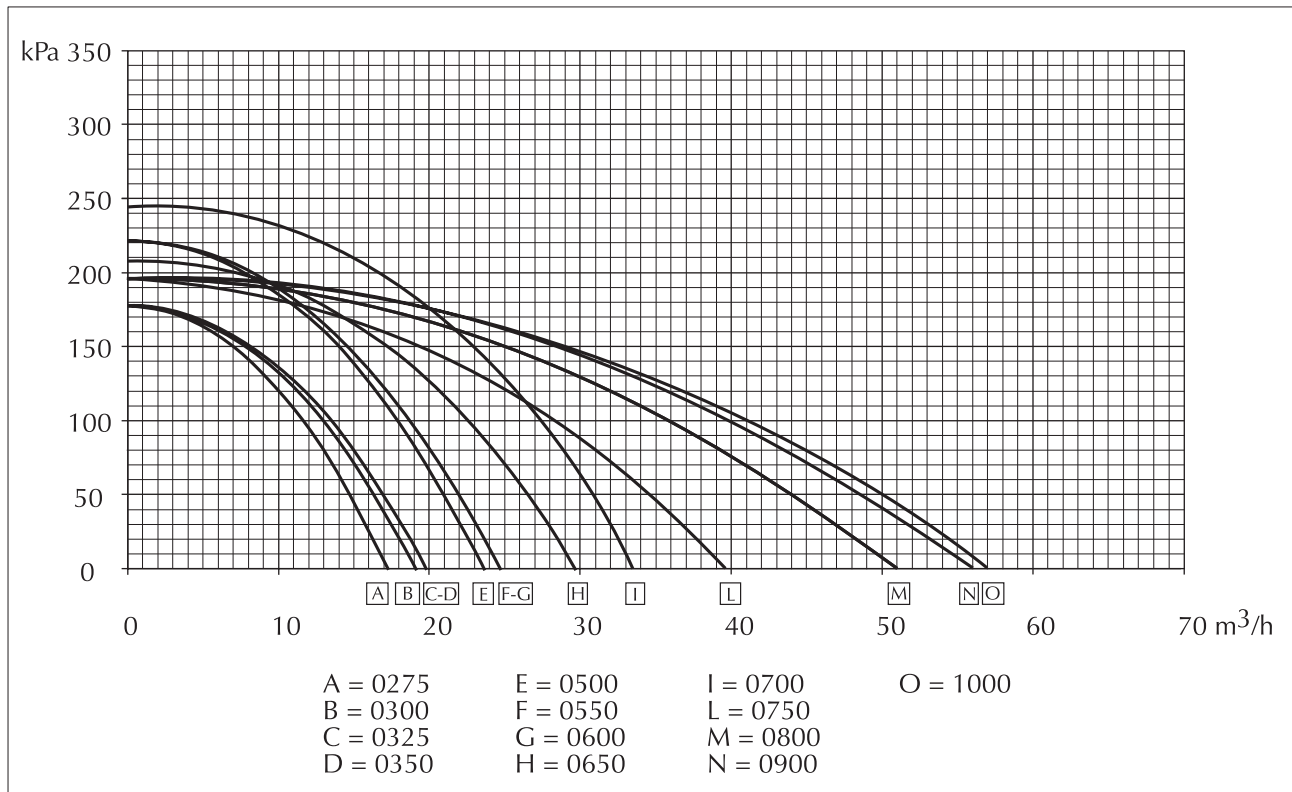

11.2 BOMBAS ALTA PREVALENCIA

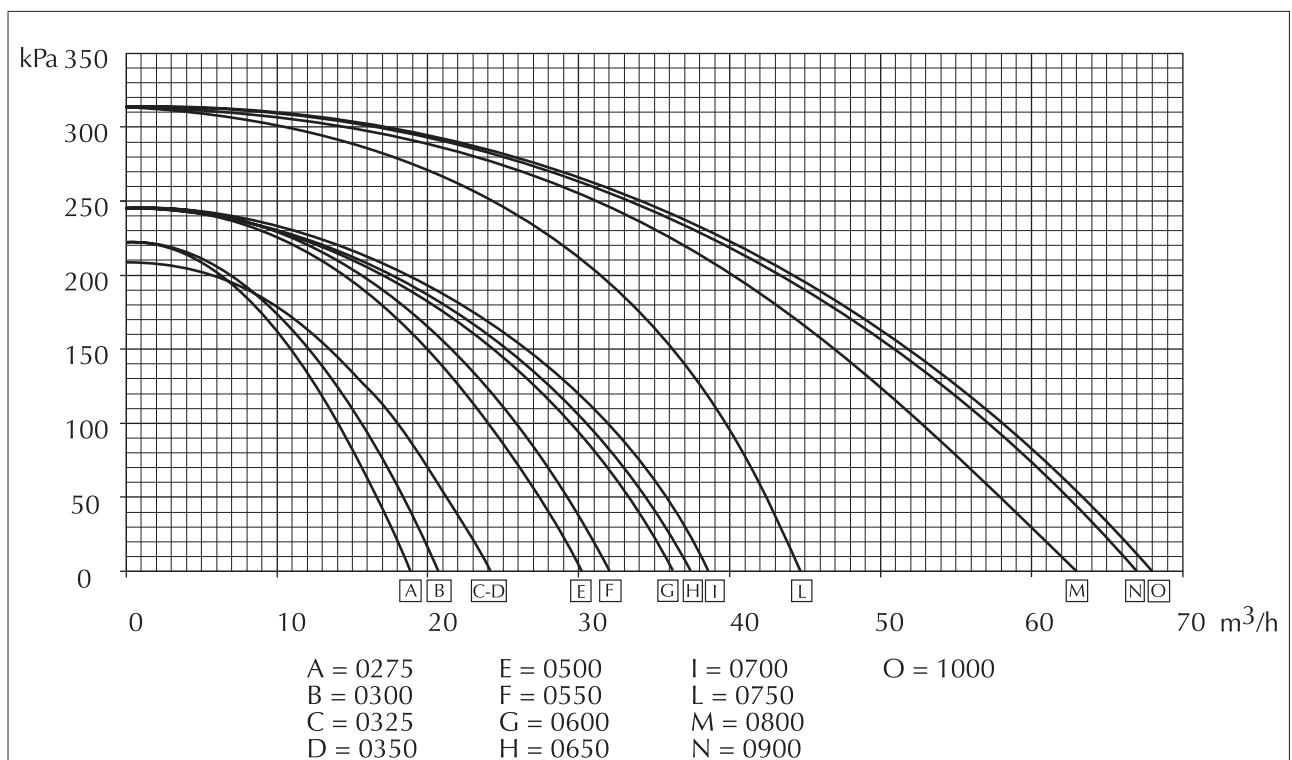

12 DESRECALENTADORES

La potencia térmica que se puede obtener del desrecalentador se consigue multiplicando el valor nominal (Pd) indicado en la tabla que se encuentra abajo de los diagramas, para un oportuno coeficiente (Cd). Los diagramas permiten obtener los coeficientes correctivos a utilizar para los enfriadores de los varios modelos; en coincidencia con cada curva se encuentra indicada la temperatura del aire externo a la cual se refiere. Las pérdidas de carga que aparecen en la tabla se deben de considerar al neto del filtro, cuya curva característica se presenta en la tabla.

El valor nominal se refiere a:
 temperatura del aire 35°C
 agua producida 50°C.

ATENCIÓN

en los modelos con bomba de calor el desrecalentador debe ser interceptado en el funcionamiento con bomba de calor; bajo pena de anulación de la garantía.

12.1 VERSION ESTÁNDAR

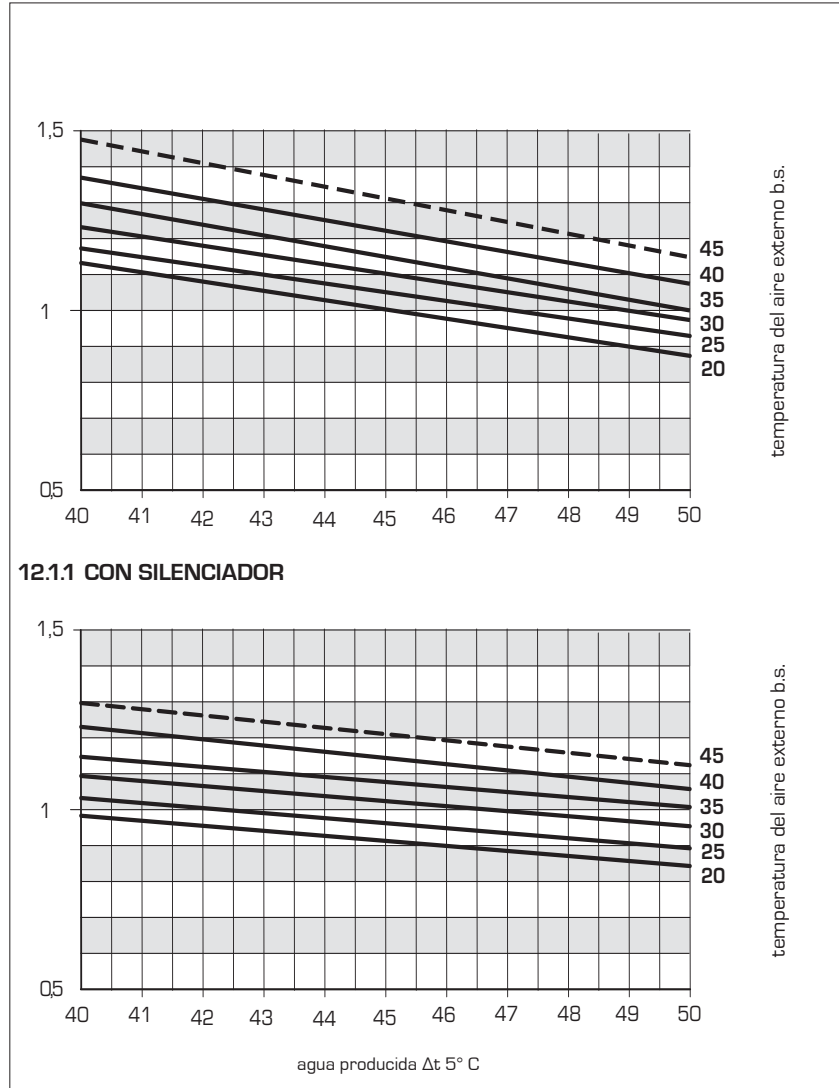

12.1.1 CON SILENCIADOR

12.1.2 DATOS NOMINALES VERSIONES ESTÁNDAR - SILENCIADAS - BOMBAS DE CALOR

VERSIÓN ESTÁNDAR													
Dimensiones	0275	0300	0325	0350	0500	0550	0600	0650	0700	0750	0800	0900	1000
Pd (Kw)	12,8	14,8	16,8	19,0	22,3	24,3	29,4	33,3	38,3	45,2	53,50	59,50	66
Qn (M3/h)	2,19	2,54	2,88	3,27	3,83	4,17	5,06	5,73	6,59	7,78	9,20	10,23	11,3
Δp (Kpa)	9,20	7,20	9,00	11,30	9,60	9,30	13,3	8,2	11,9	9,1	16	19,5	11,5

VERSIÓN SILENCIADA / VERSIONE BOMBA DE CALOR													
Dimensiones	0275	0300	0325	0350	0500	0550	0600	0650	0700	0750	0800	0900	1000
Pd (Kw)	11,5	13,5	15,5	17,5	20,3	22,3	27,8	31,7	36,0	42,6	48,5	54	59,5
Qn (M3/h)	1,98	2,32	2,67	3,01	3,48	3,83	4,78	5,44	6,19	7,32	8,34	9,3	10,2
Δp (Kpa)	8,30	6,60	8,30	10,40	8,70	8,50	11,70	7,2	10,4	7,9	-	-	-

Pd = Potencia térmica disponible en los desrecalentadores en condiciones nominales: temperatura aire 35°C e agua producida 50°C.

Qn = Caudal de agua

Δp = Pérdida de carga

12.2 VALORES DIFERENTES DEL NOMINAL

Para los valores de temperatura del agua producida con valores diferentes de 50 °C, hay que multiplicar el resultado obtenido por el factor de corrección, el cual se puede encontrar en la tabla.

Temperatura media del agua	30	40	50
Coefficiente multiplicativo	1,04	1,02	1

Para los valores de la temperatura del agua refrigerada producida diversos de 7°C o para temperaturas de evaporación diversas de 5°C, utilizar los factores correctivos de la correspondiente tabla, además de los obtenidos por los gráficos.

Temperatura del agua	5°C	7°C	9°C	11°C	13°C	15°C
Factor de corrección	0,94	1	1,07	1,13	1,2	1,27
Temperatura de evaporación	1°C	3°C	5°C	7°C	9°C	11°C
Factor de corrección	0,88	0,94	1	1,06	1,13	1,2

12.3 PÉRDIDAS DE CARGA

Los modelos NRC con desrequeadores tienen, en toda su dimensión, 2 desrequeadores situados en paralelo

NOTE

El paralelo hidráulico está al cuidado del instalador.

Las características de los desrequeadores y las curvas de las pérdidas de carga están indicadas a continuación.

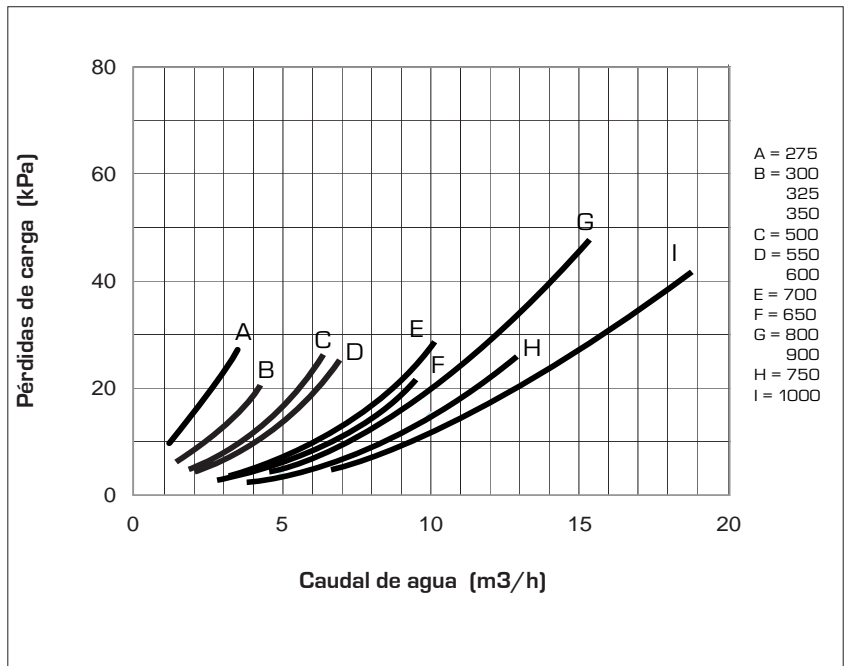

La capacidad de calentamiento disponible para la recuperación total hace referencia a las condiciones nominales:

Temperatura del aire	35 °C
Agua producida	45 °C
Δt	5 °C

12.4 PÉRDIDAS DE CARGA FILTRO DESRECALENTADOR

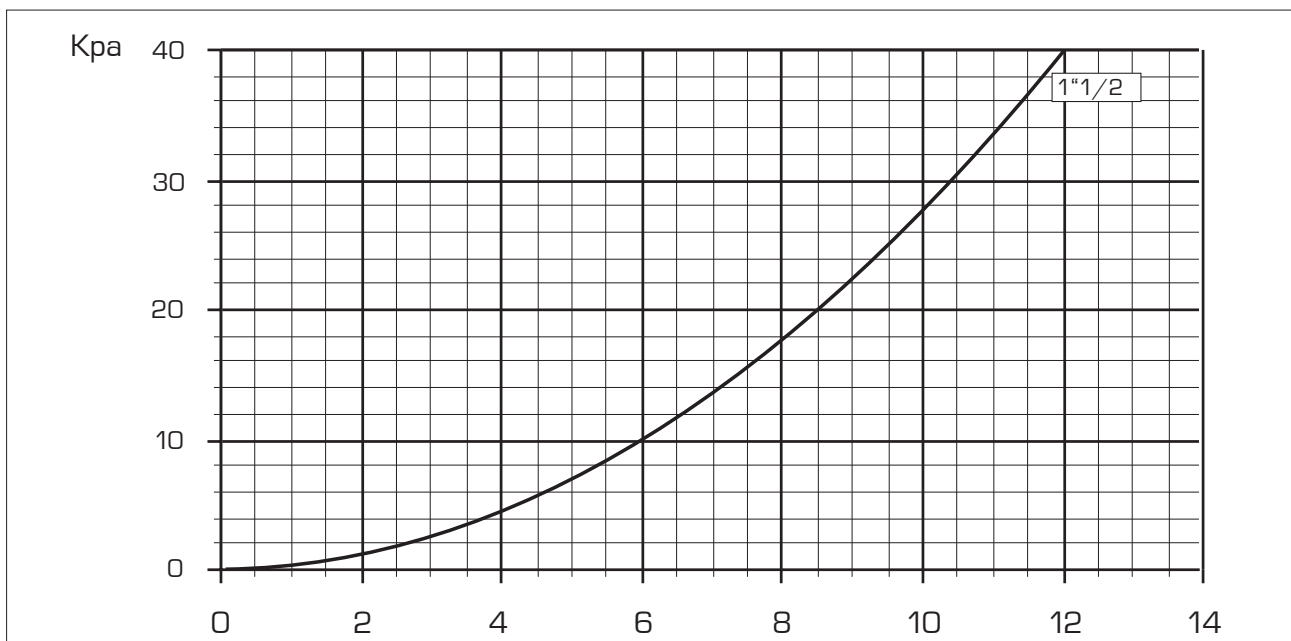

13 RECUPERACION TOTAL

En caso de funcionamiento con recuperación total de calor, los rendimientos de la máquina no dependen de la temperatura del aire externo, sino de aquella del agua caliente producida: la potencia eléctrica absorbida y la potencia térmica de recuperación se obtienen multiplicando los valores (P_a , P_r) que aparecen al pie de la página para los respectivos coeficientes correctivos (C_a , C_r), que se pueden deducir de los siguientes diagramas. En coincidencia con cada curva aparece la temperatura del agua caliente producida a la cual se refiere, asumiendo una diferencia de 5°C entre entrada y salida del recuperador total. La potencia frigorífica (P_f) se obtiene de la diferencia entre potencia térmica de recuperación (P_r) y potencia absorbida (P_a).

La capacidad de calentamiento disponible para la recuperación total hace referencia a las condiciones nominales:

Temperatura del aire	35 °C
Agua producida	50 °C
Δt	5 °C

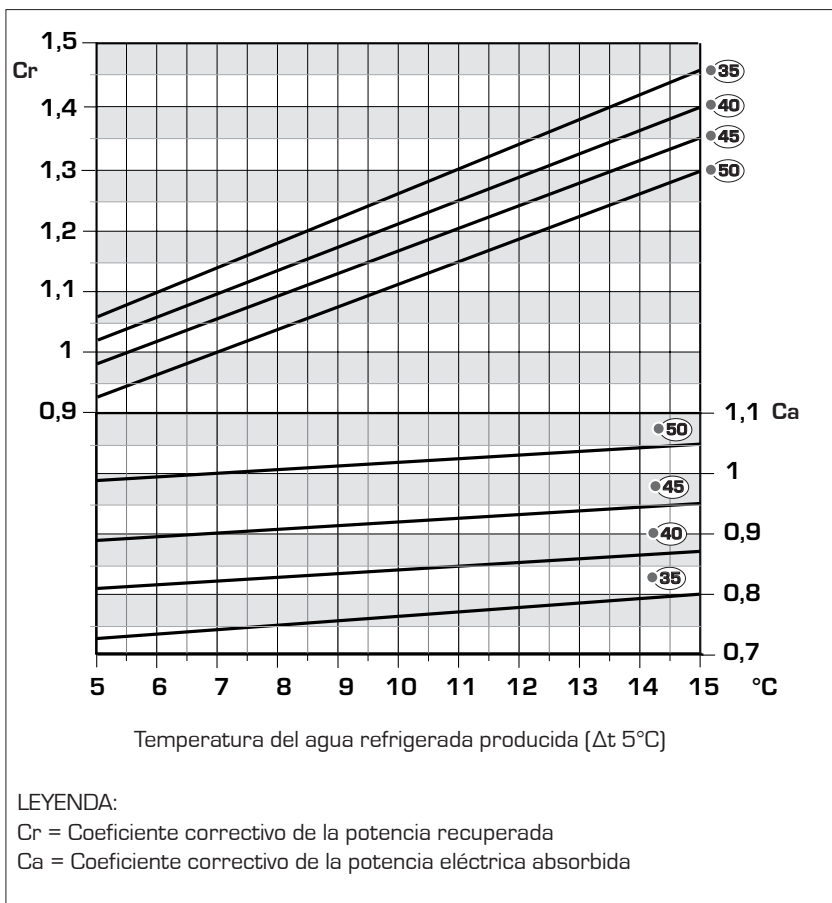

13.1 PÉRDIDAS DE CARGA

Los modelos NRC con recuperación total tienen siempre dos recuperadores (situados en paralelo). Las características de los recuperadores y las curvas de las pérdidas de carga están indicadas a continuación, no se consideran las pérdidas del filtro.

Para los valores de temperatura del agua producida a una graduación distinta de 50 °C, hay que multiplicar el resultado obtenido por el factor de corrección, el cual se puede encontrar en la tabla al final de la página. 13.1.1

NOTE

El paralelo hidráulico está al cuidado del instalador.

Las pérdidas de carga de los diagramas precedentes son relativas a una temperatura media del agua de 50 °C. La siguiente tabla (13.1.1) indica la corrección por aplicar a las pérdidas de carga al variar de la temperatura media del agua.

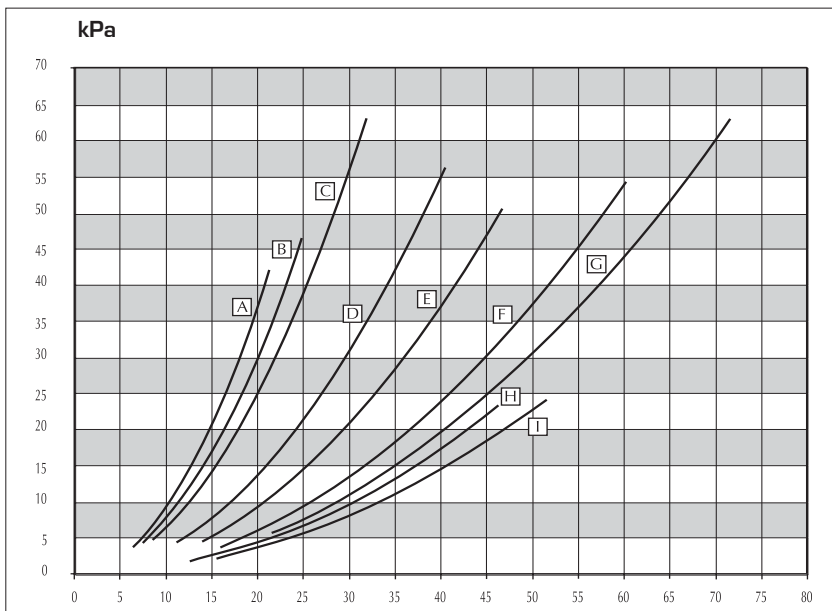

A =	0275	F =	0650 - 0700
B =	0300	G =	0750
C =	0325 - 0350	H =	0800 - 0900
D =	0500 - 0550	I =	1000
E =	0600		

13.1.1 VALORES DIFERENTES DEL NOMINAL

Temperatura media del agua	30	40	50
Coeficiente multiplicativo	1,04	1,02	1

13.1.2 PÉRDIDAS DE CARGA

Dimensiones	0275	0300	0325	0350	0500	0550	0600	0650	0700	0750	0800	0900	1000
Pr (kW)	70,0	80,5	91,0	104,0	122,0	133,0	162,9	184,9	210,6	250,1	291,7	322,1	360,1
Pa (kW)	19,56	23,19	26,49	28,23	32,96	35,76	40,99	46,99	54,6	66,1	77,69	84,14	96,13
Qn (m ³ /h)	12,79	14,96	17,12	19,13	22,28	24,32	28,02	31,80	36,22	43,02	50,17	55	62
Δp (kPa)	15,10	16,75	18,40	22,68	17,13	20,23	18,20	15,0	19,50	22,60	6,70	8,40	8,70

Pa = Potencia absorbida total
 Pr = Potencia recuperada total
 Qn = Caudal agua
 Δp = Pérdida de carga

13.1.3 PÉRDIDAS DE CARGA FILTRO RECUPERACIÓN TOTAL

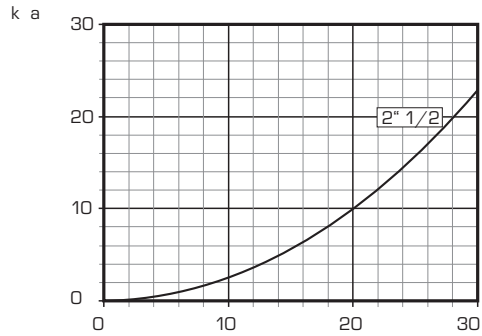

14 GRUPO DE VENTILACIÓN

14.1 DIMENSIONAMIENTO MOTOR Y POLEA FIJA PARA EL GRUPO DE VENTILACIÓN (VERSIONES ESTÁNDAR)

0275				0300			0325			0350			0500		
Qa = 16000 m ³ /h				22000 m ³ /h			22000 m ³ /h			26000 m ³ /h			27000 m ³ /h		
PSU	RPM	Pe	Ø2	RPM	Pe	Ø2	RPM	Pe	Ø2	RPM	Pe	Ø2	RPM	Pe	Ø2
(Pa)	(g/min)	(kW)	(mm)	(g/min.)	(kW)	(mm)	(g/min.)	(kW)	(mm)	(g/min.)	(kW)	(mm)	(g/min.)	(kW)	(mm)
0	635	2,44	250	565	2,91	250	565	2,91	250	592	4,07	300	604	4,64	250
20	660	2,59	250	583	3,05	250	583	3,05	250	612	4,30	300	621	4,86	250
40	685	2,73	225	601	3,21	250	601	3,21	250	631	4,52	300	639	5,10	250
60	709	2,88	225	619	3,36	250	619	3,36	250	650	4,74	300	656	5,32	250
80	733	3,04	225	637	3,51	250	637	3,51	250	669	4,99	250	673	5,56	225
100	756	3,20	200	654	3,68	225	654	3,68	225	688	5,22	250	691	5,80	225
120	780	3,29	200	672	3,85	225	672	3,85	225	706	5,45	250	708	6,05	225
140	802	3,46	200	690	4,01	225	690	4,01	225	725	5,70	250	724	6,29	225
160	825	3,62	180	706	4,18	225	706	4,18	225	743	5,83	250	741	6,39	200
180	848	3,80	180	723	4,36	225	723	4,36	225	761	6,08	225	757	6,63	200
200	869	3,98	180	740	4,45	200	740	4,45	200	779	6,32	225	774	6,86	200
220	891	4,15	180	757	4,60	200	757	4,60	200	795	6,55	225	790	7,10	200
240	913	4,24	180	773	4,79	200	773	4,79	200				806	7,36	200
260	934	4,43	180	789	4,97	200	789	4,97	200				822	7,60	200
280	953	4,60	200	805	5,14	200	805	5,14	200				837	7,86	180
300	975	4,79	200	821	5,31	200	821	5,31	200				853	8,12	180
320	996	4,98	200	836	5,49	180	836	5,49	180				868	8,38	180
340	1016	5,16	200	851	5,66	180	851	5,66	180				883	8,47	180
360				866	5,84	180	866	5,84	180				898	8,72	180
380				881	6,01	180	881	6,01	180				913	8,98	200
400				895	6,08	200	895	6,08	200				927	9,23	200
420				909	6,25	200	909	6,25	200				942	9,51	200
440													956	9,77	200

- Motor estándar
- Motor potenciado 1
- Motor potenciado 2

RPM = Número de revoluciones del ventilador.
 Pe = Potencia absorbida por el motor eléctrico.
 Ø2 = Diámetro polea fija.
 PSU = presión estática útil.

Las prestaciones relativas a la tab. aquí arriba indicadas se obtienen con poleas de diferentes diámetros
 Tal variante se debe pedir en fase de pedido; consultar la sede.

0550				0600			0650			0700		
Qa = 27000 m ³ /h				45000 m ³ /h			45000 m ³ /h			50000 m ³ /h		
PSU	RPM	Pe	Ø2	RPM	Pe	Ø2	RPM	Pe	Ø2	RPM	Pe	Ø2
(Pa)	(g/min)	(kW)	(mm)	(g/min.)	(kW)	(mm)	(g/min.)	(kW)	(mm)	(g/min.)	(kW)	(mm)
0	604	4,64	250	680	9,92	225	680	9,92	225	700	12,14	225
20	621	4,86	250	700	10,32	225	700	10,32	225	734	12,50	225
40	639	5,10	250	720	10,75	225	720	10,75	225	748	12,89	200
60	656	5,32	250	740	11,01	200	740	11,01	200	763	13,31	200
80	673	5,56	225	755	11,36	200	755	11,36	200	777	13,74	200
100	691	5,80	225	770	11,72	200	770	11,72	200	791	13,88	225
120	708	6,05	225	786	12,14	200	786	12,14	200	805	14,30	225
140	724	6,29	225	801	12,53	200	801	12,53	200	819	14,72	225
160	741	6,39	200	816	12,92	200	816	12,92	200	833	15,14	225
180	757	6,63	200	831	13,31	180	831	13,31	180	847	15,56	225
200	774	6,86	200	846	13,74	180	846	13,74	180	861	15,98	225
220	790	7,10	200	860	13,88	200	860	13,88	200	874	16,43	200
240	806	7,36	200	875	14,30	200	875	14,30	200	888	16,85	200
260	822	7,60	200	889	14,65	200	889	14,65	200	902	17,27	200
280	837	7,86	180	903	15,10	200	903	15,10	200	915	17,72	200
300	853	8,12	180	918	15,52	200	918	15,52	200	928	18,14	200
320	868	8,38	180	932	15,94	200	932	15,94	200	942	18,59	200
340	883	8,47	180	945	16,36	200	945	16,36	200	955	19,05	200
360	898	8,72	180	959	16,74	200	959	16,74	200			
380	913	8,98	200									
400	927	9,23	200									
420	942	9,51	200									
440	956	9,77	200									

0750				0800			0900			1000		
Qa = 50000 m ³ /h				60000 m ³ /h			68000 m ³ /h			68000 m ³ /h		
PSU	RPM	Pe	Ø2	RPM	Pe	Ø2	RPM	Pe	Ø2	RPM	Pe	Ø2
(Pa)	(g/min)	(kW)	(mm)	(g/min.)	(kW)	(mm)	(g/min.)	(kW)	(mm)	(g/min.)	(kW)	(mm)
0	700	12,14	225	761	15,34	200	800	19,40	225	861	21,91	200
20	734	12,50	225	776	15,86	200	814	19,95	225	874	22,47	200
40	748	12,89	200	791	16,38	200	827	20,51	225	888	23,07	200
60	763	13,31	200	806	16,90	200	841	20,93	225	901	23,63	200
80	777	13,74	200	821	17,42	200	855	21,63	225	915	24,23	200
100	791	13,88	225	836	17,99	200	868	22,23	225	928	24,41	200
120	805	14,30	225	850	18,03	225	882	22,79	200	941	24,96	200
140	819	14,72	225	865	18,70	225	895	23,40	200	954	25,55	200
160	833	15,14	225	879	19,21	200	909	23,95	200	967	26,15	200
180	847	15,56	225	893	19,77	200	922	24,56	200	980	26,74	200
200	861	15,98	225	908	19,77	200	935	25,16	200	993	27,34	200
220	874	16,43	200	922	20,33	200	948	25,72	200			
240	888	16,85	200	936	20,84	200	961	26,33	200			
260	902	17,27	200	950	21,40	200	974	26,93	200			
280	915	17,72	200	963	21,95	200						
300	928	18,14	200									
320	942	18,59	200									
340	955	19,05	200									

- Motor estándar
- Motor potenciado 1
- Motor potenciado 2

RPM = Número de revoluciones del ventilador.

Pe = Potencia absorbida por el motor eléctrico

Ø2 = Diámetro polea fija.

PSU = presión estática útil.

Las prestaciones relativas a la tab. aquí arriba indicadas se obtienen con poleas de diferentes diámetros.

Tal variante se debe pedir en fase de pedido; consultar la sede.

14.2 DIMENSIONAMIENTO MOTOR Y POLEA FIJA PARA EL GRUPO DE VENTILACIÓN (VERSIONES SILENCIADAS)

0275				0300			0325			0350			0500		
Qa = 11000 m ³ /h				15500 m ³ /h			15500 m ³ /h			18000 m ³ /h			19000 m ³ /h		
PSU	RPM	Pe	Ø2	RPM	Pe	Ø2	RPM	Pe	Ø2	RPM	Pe	Ø2	RPM	Pe	Ø2
(Pa)	(g/min)	(kW)	(mm)	(g/min.)	(kW)	(mm)	(g/min.)	(kW)	(mm)	(g/min.)	(kW)	(mm)	(g/min.)	(kW)	(mm)
0	525	1,09	280	496	1,48	300	496	1,48	300	501	1,95	300	497	2,12	300
20	560	1,20	280	520	1,61	300	520	1,61	300	527	2,12	300	521	2,30	300
40	592	1,32	250	544	1,73	280	544	1,73	280	553	2,30	300	544	2,47	280
60	624	1,46	250	566	1,85	280	566	1,85	280	578	2,47	250	567	2,64	280
80	654	1,58	250	588	1,98	280	588	1,98	280	602	2,66	250	589	2,84	280
100	684	1,72	225	610	2,10	250	610	2,10	250	626	2,89	250	611	3,01	250
120	713	1,85	225	630	2,24	250	630	2,24	250	649	3,03	250	632	3,21	250
140	742	2,00	225	651	2,37	250	651	2,37	250	671	3,22	250	653	3,41	250
160	770	2,14	200	670	2,50	250	670	2,50	250	693	3,42	225	674	3,60	250
180	797	2,24	200	689	2,62	225	689	2,62	225	715	3,61	225	694	3,80	225
200	824	2,38	200	708	2,76	225	708	2,76	225	736	3,81	225	713	4,00	225
220	850	2,53	180	726	2,89	225	726	2,89	225	756	3,94	200	732	4,20	225
240	875	2,66	180	744	3,02	225	744	3,02	225	776	4,14	200	751	4,40	225
260	900	2,83	180	761	3,09	200	761	3,09	200	796	4,35	200	769	4,59	200
280	924	2,97	180	778	3,21	200	778	3,21	200				787	4,72	200
300	948	3,13	180	794	3,34	200	794	3,34	200				805	4,91	200
320				810	3,47	200	810	3,47	200				822	5,13	200
340				826	3,59	200	826	3,59	200				839	5,32	200

0550				0600			0650			0700		
Qa = 19000 m ³ /h				31500 m ³ /h			31500 m ³ /h			35000 m ³ /h		
PSU	RPM	Pe	Ø2	RPM	Pe	Ø2	RPM	Pe	Ø2	RPM	Pe	Ø2
(Pa)	(g/min)	(kW)	(mm)	(g/min.)	(kW)	(mm)	(g/min.)	(kW)	(mm)	(g/min.)	(kW)	(mm)
0	497	2,12	300	598	5,00	250	598	5,00	250	642	6,28	250
20	521	2,30	300	618	5,30	250	618	5,30	250	661	6,60	250
40	544	2,47	280	639	5,59	250	639	5,59	250	679	6,93	225
60	567	2,64	280	659	5,89	250	659	5,89	250	698	7,26	225
80	589	2,84	280	678	6,22	225	678	6,22	225	715	7,62	225
100	611	3,01	250	698	6,52	225	698	6,52	225	733	7,94	225
120	632	3,21	250	717	6,85	225	717	6,85	225	751	8,31	200
140	653	3,41	250	735	7,15	225	735	7,15	225	768	8,63	200
160	674	3,60	250	753	7,48	200	753	7,48	200	786	8,96	200
180	694	3,80	225	771	7,65	200	771	7,65	200	802	9,32	200
200	713	4,00	225	789	7,98	200	789	7,98	200	819	9,69	180
220	732	4,20	225	806	8,31	200	806	8,31	200	836	10,01	180
240	751	4,40	225	823	8,63	200	823	8,63	200	852	10,37	180
260	769	4,59	200	840	8,96	180	840	8,96	180			
280	787	4,72	200	856	9,29	180	856	9,29	180			
300	805	4,91	200	873	9,65	180	873	9,65	180			
320	822	5,13	200									
340	839	5,32	200									

- Motor estándar
- Motor potenciado 1
- Motor potenciado 2

RPM = Número de revoluciones del ventilador.

Pe = Potencia absorbida por el motor eléctrico

Ø2 = Diámetro polea fija.

PSU = presión estática útil.

Las prestaciones relativas a la tab. aquí arriba indicadas se obtienen con poleas de diferentes diámetros.

Tal variante se debe pedir en fase de pedido; consultar la sede.

0750				0800			0900			1000		
Qa = 35000 m3/h				42000 m3/h			47600 m3/h			47600 m3/h		
PSU	RPM	Pe	Ø2	RPM	Pe	Ø2	RPM	Pe	Ø2	RPM	Pe	Ø2
(Pa)	(g/min)	(kW)	(mm)	(g/min.)	(kW)	(mm)	(g/min.)	(kW)	(mm)	(g/min.)	(kW)	(mm)
0	642	6,28	250	629	7,26	225	643	8,89	225	689	10,02	225
20	661	6,60	250	649	7,65	225	662	9,28	225	708	10,21	225
40	679	6,93	225	669	8,10	225	680	9,78	225	725	10,69	225
60	698	7,26	225	688	8,49	225	698	10,22	225	743	11,12	200
80	715	7,62	225	707	8,94	225	717	10,45	225	761	11,61	200
100	733	7,94	225	726	9,33	225	734	10,88	200	778	12,04	200
120	751	8,31	200	744	9,78	200	752	11,37	200	795	12,53	200
140	768	8,63	200	762	10,22	200	769	11,80	200	811	12,96	200
160	786	8,96	200	780	10,40	200	786	12,29	200	828	13,45	200
180	802	9,32	200	798	10,83	200	803	12,77	180	844	13,93	180
200	819	9,69	180	815	11,32	200	820	13,20	180	860	14,11	180
220	836	10,01	180	832	11,75	180	836	13,69	180	876	14,58	180
240	852	10,37	180	848	12,19	180	852	13,87	180	891	15,05	180
260				865	12,62	180	868	14,34	180			
280				881	13,11	180	883	14,82	180			

- Motor estándar
- Motor potenciado 1
- Motor potenciado 2

RPM = Número de revoluciones del ventilador.
 Pe = Potencia absorbida por el motor eléctrico.
 ø2 = Diámetro polea fija.
 PSU = presión estática útil.

Las prestaciones relativas a la tab. aquí arriba indicadas se obtienen con poleas de diferentes diámetros.
 Tal variante se debe pedir en fase de pedido; consultar la sede.

Potencias motores para versiones estándar y potenciadas														
		0275	0300	0325	0350	0500	0550	0600	0650	0700	0750	0800	0900	1000
Versión estándar	[kW]	3	4	4	5,5	2X3	2X3	3X4	3X4	3X4	3X4	4X4	4X5,5	4X5,5
Versión potenciada 1	[kW]	4	5,5	5,5	7,5	2X4	2X4	3X5,5	3X5,5	3X5,5	3X5,5	4X5,5	4X7,5	4X7,5
Versión potenciada 2	[kW]	5,5	7,5	7,5	-	2X5,5	2X5,5	-	-	3X7,5	3X7,5	-	-	-
VERSIONES SILENCIADAS (L)														
		0275	0300	0325	0350	0500	0550	0600	0650	0700	0750	0800	0900	1000
Versión estándar	[kW]	2,2	3	3	4	2X2,2	2X2,2	3X2,2	3X2,2	3X2,2	3X2,2	4X2,2	4X2,2	4X2,2
Versión potenciada 1	[kW]	3	4	4	-	2X3	2X3	3X3	3X3	3X3	3X3	4X3	4X3	4X3
Versión potenciada 2	[kW]	-	-	-	-	-	-	-	-	-	-	-	4X4	4X4

15 DATOS SONOROS

Potencia sonora

Aermec determina el valor de la potencia sonora en base a las medidas efectuadas de acuerdo con la normativa 9614, en conformidad con lo requerido por la certificación Eurovent.

(1) Presión sonora

Presión sonora en campo libre sobre plano reflectante (factor de direccionalidad Q=2), a 10 m de distancia de la superficie externa de la unidad, con el método del paralelo expandido (box-method, ISO 3744)

NOTA

Condiciones de funcionamiento:
 Agua evaporador (in/out) 12/7 °C
 Aire condensador 35 °C

NOTA

Los datos se calculan en frío

[°]	Niveles sonoros totales			Banda de octava [Hz]						
	Pot. dB (A)	Presión		125	250	500	1000	2000	4000	8000
		dB (A) 10 m	dB 1 m							
Potencia sonora para frecuencia central de banda [dB]										
0275	85	53,0	67	82,2	80,7	81,6	78,9	78,6	75,1	65,9
0300	85	53,0	67	82,2	80,7	81,6	78,9	78,6	75,1	65,9
0325	85,5	54,0	67,5	84,4	79,5	80,2	80,6	79,9	75,9	68
0350	88,5	56,0	70,5	86,6	81,3	83,9	82,3	83,2	78,9	70,1
0500	88	56,0	70	85,8	81,6	83,6	81,8	83	78,7	70
0550	88	56,0	70	85,2	82,1	84,8	82,4	82,5	78,2	70,7
0600	90	58,0	72	89,4	84,2	85,4	84,1	84,2	80,8	71,8
0650	90	58,0	72	89,4	84,2	85,4	84,1	84,2	80,8	71,8
0700	91	59,0	73	86,8	85,5	87	85,1	84,6	82,5	73,9
0750	91	59,0	73	90,2	85,8	87,2	85,4	85,4	82,9	74,1
0800	92	60,0	74	91,5	86,1	87,8	85,9	85,9	83,7	74,6
0900	92,5	60,0	74,5	91,5	86,8	88,4	86,5	86,1	84,1	74,6
1000	92,5	60,0	74,5	91,5	86,8	88,4	86,5	86,1	84,1	74,6

[L]	Niveles sonoros totales			Banda de octava [Hz]						
	Pot. dB (A)	Presión		125	250	500	1000	2000	4000	8000
		dB (A) 10 m	dB 1 m							
Potencia sonora para frecuencia central de banda [dB]										
0275	81	49	63	78	76,5	77,2	74,9	74,7	72,2	61
0300	81	49	63	78	76,5	77,2	74,9	74,7	72,2	61
0325	82	50	64	79,4	76,8	76,5	77	76,2	72,1	64,2
0350	84	52	66	81,6	76,6	78,9	77,7	78,9	74,9	66,1
0500	84	52	66	81	76,8	78,5	77,9	79	75	66,2
0550	84	52	66	81	76,8	78,5	77,9	79	75	66,2
0600	86	54	68	83,3	81,4	83,3	80,7	79,2	75,5	66,4
0650	86	54	68	83,3	81,4	83,3	80,7	79,2	75,5	66,4
0700	87	55	69	82,4	82,2	84,6	81,6	79,6	77,2	68,5
0750	87	55	69	82,4	82,2	84,6	81,6	79,6	77,2	68,5
0800	88	56	70	86,5	83,1	85,4	82,4	80,8	78,4	69,2
0900	88,5	56,5	70,5	86,5	83,8	86,1	83,1	81,1	78,8	69,2
1000	88,5	56,5	70,5	86,5	83,8	86,1	83,1	81,1	78,8	69,2

[H]	Niveles sonoros totales			Banda de octava [Hz]						
	Pot. dB (A)	Presión		125	250	500	1000	2000	4000	8000
		dB (A) 10 m	dB 1 m							
Potencia sonora para frecuencia central de banda [dB]										
0275	84,9	53,0	66,9	82,2	80,7	81,6	78,9	78,6	75,1	65,9
0300	84,9	53,0	66,9	82,2	80,7	81,6	78,9	78,6	75,1	65,9
0325	85,6	54,0	67,6	84,4	79,5	80,2	80,6	79,9	75,9	68
0350	88,4	56,0	70,4	86,6	81,3	83,9	82,3	83,2	78,9	70,1
0500	88,2	56,0	70,2	85,8	81,6	83,6	81,8	83	78,7	70
0550	88,3	56,0	70,3	85,2	82,1	84,8	82,4	82,5	78,2	70,7
0600	90	58,0	72	89,4	84,2	85,4	84,1	84,2	80,8	71,8
0650	90	58,0	72	89,4	84,2	85,4	84,1	84,2	80,8	71,8
0700	91	59,0	73	86,8	85,5	87	85,1	84,6	82,5	73,9
0750	91	59,0	73	90,2	85,8	87,2	85,4	85,4	82,9	74,1
0800	92	60,0	74	91,5	86,1	87,8	85,9	85,9	83,7	74,6
0900	92,5	60,0	74,5	91,5	86,8	88,4	86,5	86,1	84,1	74,6
1000	92,5	60,0	74,5	91,5	86,8	88,4	86,5	86,1	84,1	74,6

16 PARCIALIZACIONES

16.1 VERSIONES ESTÁNDAR (°)

Potencia de refrigeración %	Niveles de potencia			
Versiones	1°	2°	3°	4°
0275	50	100	-	-
0300	57/43	100	-	-
0325	50	100	-	-
0350	50	100	-	-
0500	39	78	100	-
0550	38	76	100	-
0600	30	61	80	100
0650	30	61	80	100
0700	30	61	80	100
0750	30	61	80	100
0800	30	60	80	100
0900	30	60	80	100
1000	30	60	80	100
Potencia absorbida %	Niveles de potencia			
Versiones	1°	2°	3°	4°
0275	50	100	-	-
0300	57/43	100	-	-
0325	50	100	-	-
0350	50	100	-	-
0500	37	69	100	-
0550	34	68	100	-
0600	30	61	80	100
0650	30	61	80	100
0700	30	61	80	100
0750	30	61	80	100
0800	30	60	80	100
0900	30	60	80	100
1000	30	60	80	100

16.2 VERSIONES BOMBA DE CALOR (H)

Potencia térmica %	Niveles de potencia			
Versiones	1°	2°	3°	4°
0275	50	100	-	-
0300	57/43	100	-	-
0325	50	100	-	-
0350	50	100	-	-
0500	37	75	100	-
0550	36	73	100	-
0600	30	61	80	100
0650	30	61	80	100
0700	30	61	80	100
0750	30	61	80	100
0800	30	60	80	100
0900	30	60	80	100
1000	30	60	80	100
Potencia absorbida %	Niveles de potencia			
Versiones	1°	2°	3°	4°
0275	50	100	-	-
0300	57/43	100	-	-
0325	50	100	-	-
0350	50	100	-	-
0500	37	69	100	-
0550	34	68	100	-
0600	30	61	80	100
0650	30	61	80	100
0700	30	61	80	100
0750	30	61	80	100
0800	30	60	80	100
0900	30	60	80	100
1000	30	60	80	100

Durante el enfriamiento

- Temperatura agua en salida
- Temperatura aire externo

7 °C
35 °C

Durante el calentamiento

- Temperatura agua en salida
- Temperatura aire externo

50 °C
b.s. 7 °C/ b.u. 6 °C

Nota

Los rendimientos se refieren a las siguientes condiciones:

temperatura del agua producida = 7 °C;

temperatura de aire externo = 35 °C.

temperatura del agua producida = 50 °C;

temperatura del aire

externo = 7 °C B.S. - 6 °C B.U.

ATENCIÓN

Como se deduce de la tabla,

parcialmente la reducción de la potencia absorbida es superior a la reducción de la potencia de rendimiento, obteniendo de este modo un E.E.R. superior al que está en funcionamiento en plena carga.

Esto porque en parcialización la máquina se encuentra con intercambiadores "sobredimensionados" respecto a

las correspondientes capacidades refrigerantes, permitiendo así una mayor eficacia energética.

Por tal motivo esta serie de aparatos está particularmente indicada para reducir los consumos energético con carga variable (típico de las aplicaciones de comfort).

17 CALIBRADO PARÁMETROS DE CONTROL Y DE SEGURIDAD

17.1 PARÁMETROS DE CONTROL

NOTAS

(1) = Versión Y

		min.	standard	max.
Set point enfriamiento	°C	4 / -6 (1)	7 / -6 (1)	14
Set point calentamiento	°C	35	48	50
Intervención antihielo	°C	-9	3	4
Diferencial total	°C	3	5	10
Autostart		auto		

MAGENTOTÉRMICOS VENTILADORES

Versión	0275	0300	0325	0350	0500	0550	0600	0650	0700	0750	0800	0900	1000
(°) [A]	7,2	9	9	12	7,2X2	7,2X2	7,2X3	7,2X3	9X3	9X3	9X4	9X4	12X4
L [A]	7,2	9	9	12	7,2X2	7,2X2	-	-	-	-	-	-	-

MAGENTOTÉRMICOS COMPRESORES (VERSIONES ESTÁNDAR Y SILENCIADAS)

	0275	0300	0325	0350	0500	0550	0600	0650	0700	0750	0800	0900	1000
A	22X2	22	28X2	33X2	22X2	22	20X2	25X4	30X4	39X2	39X4	39X2	48X4
		28			33	28	25X2			30X2		48X2	

PRESOSTATO ALTA PRESIÓN (VERSIONES ESTÁNDAR Y SILENCIADAS)

	0275	0300	0325	0350	0500	0550	0600	0650	0700	0750	0800	0900	1000
(bar)	28	28	28	28	28	28	28	28	28	28	28	28	28

PRESOSTATO BAJA PRESIÓN (VERSIONES ESTÁNDAR Y SILENCIADAS)

	0275	0300	0325	0350	0500	0550	0600	0650	0700	0750	0800	0900	1000
(bar)	2	2	2	2	2	2	2	2	2	2	2	2	2

TRANSDUCTOR DE ALTA PRESIÓN (VERSIONES ESTÁNDAR Y SILENCIADAS)

	0275	0300	0325	0350	0500	0550	0600	0650	0700	0750	0800	0900	1000
(bar)	28	28	28	28	28	28	28	28	28	28	28	28	28

MAGENTOTÉRMICOS VENTILADORES

Versión	0275	0300	0325	0350	0500	0550	0600	0650	0700	0750	0800	0900	1000
H [A]	7,2	9	9	12	7,2X2	7,2X2	7,2X3	7,2X3	9X3	9X3	9X4	9X4	12X4

MAGENTOTÉRMICOS COMPRESORES (VERSIONES BOMBA DE CALOR)

	0275	0300	0325	0350	0500	0550	0600	0650	0700	0750	0800	0900	1000
[A]	22X2	22	28X2	33X2	22X2	22	20X2	25X4	30X4	39X2	39X4	39X2	48X4
		28			33	28	25X2			30X2		48X2	

INTERRUPTOR GENERAL

Versión	0275	0300	0325	0350	0500	0550	0600	0650	0700	0750	0800	0900	1000
[A]	80	80	100	100	125	125	200	200	200	250	315	315	350

PRESOSTATO ALTA PRESIÓN (VERSIONES BOMBAS DE CALOR)

	0275	0300	0325	0350	0500	0550	0600	0650	0700	0750	0800	0900	1000
(bar)	28	28	28	28	28	28	28	28	28	28	28	28	28

PRESOSTATO ALTA PRESIÓN (VERSIONES BOMBAS DE CALOR)

	0275	0300	0325	0350	0500	0550	0600	0650	0700	0750	0800	0900	1000
(bar)	28	28	28	28	28	28	28	28	28	28	28	28	28

PRESOSTATO BAJA PRESIÓN (VERSIONES BOMBAS DE CALOR)

	0275	0300	0325	0350	0500	0550	0600	0650	0700	0750	0800	0900	1000
(bar)	1	1	1	1	1	1	1	1	1	1	1	1	1

18 DIMENSIONES

18.1 TABLAS DIMENSIONALES

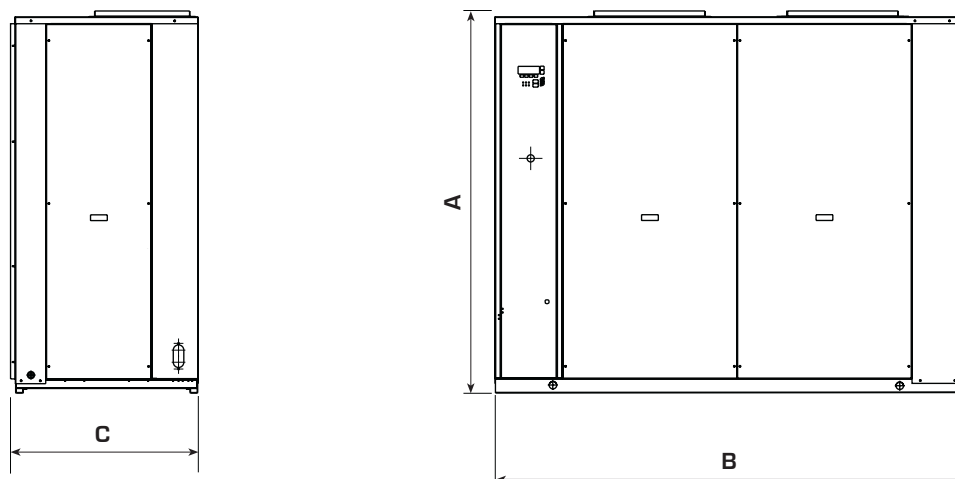

DIMENSIONES VERSIONES ESTÁNDAR, SILENCIADAS Y BOMBAS DE CALOR NRC 00 - P1 - P2 - P3 - P4

MODELO		0275	0300	0325	0350	0500	0550	0600	0650	0700	0750	0800	0900	1000
A	mm	1763	1793	1793	1763	1963	1963	2288	2288	2288	2288	2295	2295	2295
B	mm	2100	2100	2100	2450	2450	2450	3750	3750	4550	4550	4950	4950	4950
C	mm	950	950	950	950	950	950	1100	1100	1100	1100	1300	1300	1300

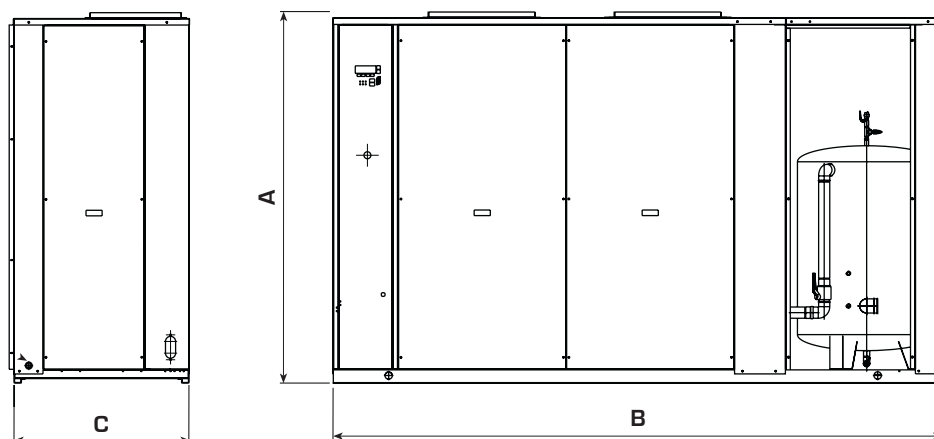

DIMENSIONES VERSIONES ESTÁNDAR, SILENCIADAS Y BOMBAS DE CALOR CON ACUMULACIÓN NRC 01 - 02 - 03 - 04 - 05 - 06 - 07 - 08

MODELO		0275	0300	0325	0350	0500	0550	0600	0650	0700	0750	0800	0900	1000
A	mm	1763	1793	1793	1763	1963	1963	2288	2288	2288	2288	2295	2295	2295
B	mm	2950	2950	2950	3300	3300	3300	4550	4550	5350	5350	5750	5750	5750
C	mm	950	950	950	950	950	950	1100	1100	1100	1100	1300	1300	1300

18.2 ESPACIOS TÉCNICOS MÍNIMOS

[mm]	A	B	C	D
NRC 0275	1100	800	800	800
NRC 0300	1100	800	800	800
NRC 0325	1100	800	800	800
NRC 0350	1100	800	800	800
NRC 0500	1100	800	800	800
NRC 0550	1100	800	800	800
NRC 0600	1100	800	800	800
NRC 0650	1100	800	800	800
NRC 0700	1100	800	800	800
NRC 0750	1100	800	800	800
NRC 0800	1100	800	800	800
NRC 0900	1100	800	800	800
NRC 1000	1100	800	800	800

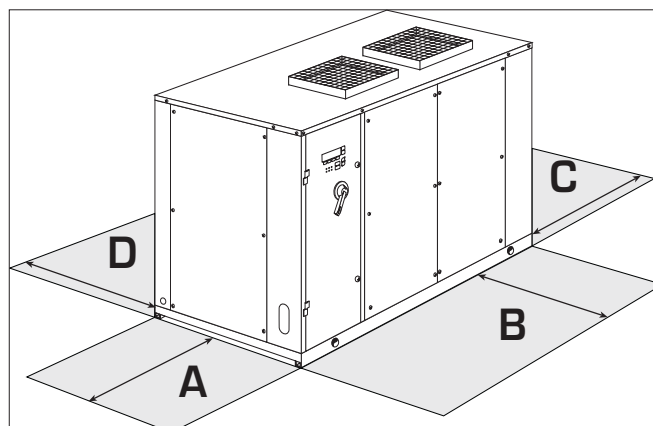

19 PESOS Y BARICENTROS

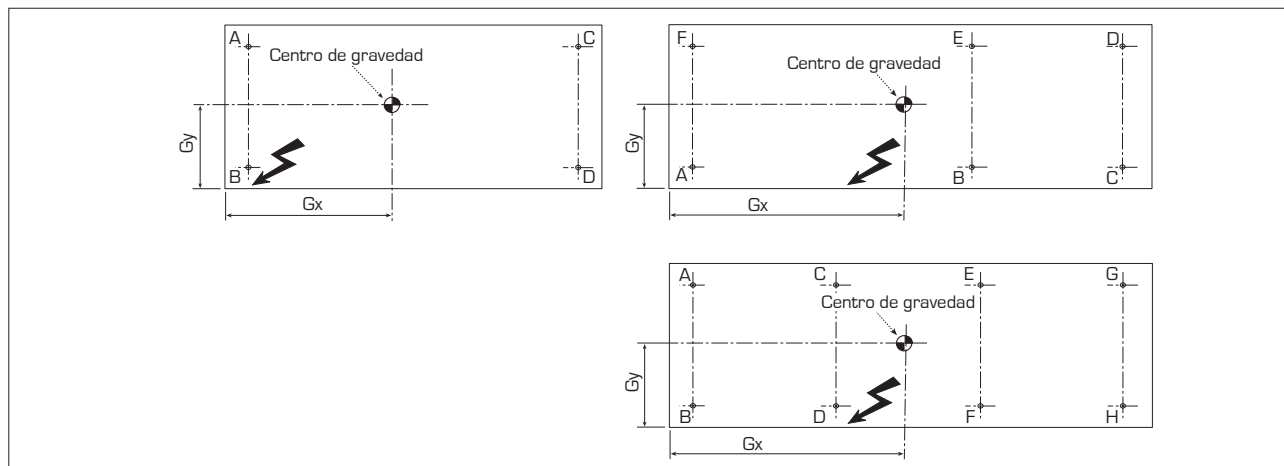

VERSIÓN BASE (°) (1) - SIN ACUMULACIÓN

Dimensiones		0275	0300	0325	0350	0500	0550	0600	0650	0700	0750	0800	0900	1000
Peso	Kg	629	665	699	777	904	919	1481	1498	1737	1918	2670	2700	2960
Gx	(mm)	1132	1142	1124	1310	1279	1279	1883	1891	2193	2206	2233	2236	2259
Gy	(mm)	390	389	388	398	396	396	493	490	493	496	480	482	466
A	%	18,9	18,7	19,0	19,5	19,9	19,9	21	21	12	12	19	19	19
B	%	27,2	26,9	27,5	27,0	27,9	27,9	21	21	31	31	15	15	15
C	%	22,1	22,3	21,8	22,4	21,7	21,7	29	29	7	7	22	22	21
D	%	31,8	32,1	31,7	31,1	30,5	30,5	29	29	7	7	17	17	17
E	%	-	-	-	-	-	-	-	-	31	31	4	4	5
F	%	-	-	-	-	-	-	-	-	12	12	4	4	4
G	%	-	-	-	-	-	-	-	-	-	-	11	11	11
H	%	-	-	-	-	-	-	-	-	-	-	8	8	9

VERSIÓN CON ACUMULACIÓN VACÍA

Dimensiones		0275	0300	0325	0350	0500	0550	0600	0650	0700	0750	0800	0900	1000
Gx	(mm)	1425	1420	1395	1579	1518	1518	2203	2203	2535	2518	2476	2476	2479
Gy	(mm)	407	405	405	430	409	409	507	505	505	507	503	505	489

VERSIÓN CON SÓLO GRUPO BOMBAS

Dimensiones		0275	0300	0325	0350	0500	0550	0600	0650	0700	0750	0800	0900	1000
PESO	(kg)	663	699	733	811	938	953	1659	1676	1914	2096	2870	2900	3160

VERSIÓN CON ACUMULACIÓN LLENA DE AGUA (500/700 litros) (2)

Dimensiones		0275	0300	0325	0350	0500	0550	0600	0650	0700	0750	0800	0900	1000
Peso	Kg	1327	1391	1401	1496	1621	1638	2243	2260	2498	2680	3770	3800	4050
Gx	(mm)	1839	1817	1798	2012	1931	1931	2203	2203	2535	2518	3012	3008	2975
Gy	(mm)	432	430	430	445	429	429	507	505	505	507	491	492	480
A	%	17,1	17,4	17,7	18,3	18,7	18,7	12	12	13	13	16	16	16
B	%	20,5	21,0	21,4	20,7	22,8	22,8	12	12	13	13	9	9	9
C	%	28,4	27,9	27,6	28,6	26,4	26,4	31	31	25	25	17	17	18
D	%	34,0	33,7	33,4	32,4	32,1	32,1	31	31	25	25	9	9	10
E	%	-	-	-	-	-	-	7	7	12	12	13	13	14
F	%	-	-	-	-	-	-	7	7	12	12	7	7	7
G	%	-	-	-	-	-	-	-	-	-	-	18	18	18
H	%	-	-	-	-	-	-	-	-	-	-	10	10	10

VERSIÓN BOMBA DE CALOR (H) (1)

Dimensiones		0275H	0300H	0325H	0350H	0500H	0550H	0600H	0650H	0700H	0750H	0800H	0900H	1000H
Peso	Kg	689	737	748	841	983	999	1593	1610	1931	2001	2797	2827	3095
Gx	(mm)	1108	1126	1098	1300	1271	1271	1883	1886	2187	2200	2244	2247	2268
Gy	(mm)	402	396	398	431	411	411	506	504	504	503	487	489	473
A	%	20,0	19,4	20,0	21,3	20,8	20,8	21	21	12	12	19	19	19
B	%	27,3	27,0	27,8	25,7	27,3	27,3	21	21	12	12	15	15	15
C	%	22,3	22,4	21,9	24,1	22,4	22,4	29	29	31	31	22	22	24
D	%	30,4	31,2	30,4	29,0	29,4	29,4	29	29	31	31	17	17	17
E	%	-	-	-	-	-	-	-	-	7	7	4	4	5
F	%	-	-	-	-	-	-	-	-	7	7	4	4	4
G	%	-	-	-	-	-	-	-	-	-	-	11	11	11
H	%	-	-	-	-	-	-	-	-	-	-	8	8	9

VERSIÓN SÓLO CON GRUPO BOMBAS (MODELOS BOMBA DE CALOR)														
Dimensiones		0275H	0300H	0325H	0350H	0500H	0550H	0600H	0650H	0700H	0750H	0800H	0900H	1000H
PESO	(kg)	723	771	782	875	1017	1033	1771	1788	2009	2179	2997	3027	3295
VERSIÓN CON ACUMULACIÓN VACÍA ⁽²⁾ (MODELOS BOMBA DE CALOR)														
Dimensiones		0275H	0300H	0325H	0350H	0500H	0550H	0600H	0650H	0700H	0750H	0800H	0900H	1000H
Gx	(mm)	1396	1396	1396	1565	1503	1503	2036	2187	2515	2502	2475	2475	2476
Gy	(mm)	418	411	412	439	420	420	518	515	514	513	508	509	493
VERSIÓN CON ACUMULACIÓN LLENA DE AGUA (500/700 litros) ⁽²⁾ (MODELOS BOMBA DE CALOR)														
Dimensiones		0275H	0300H	0325H	0350H	0500H	0550H	0600H	0650H	0700H	0750H	0800H	0900H	1000H
Peso	Kg	1365	1420	1430	1530	1694	1710	2355	2372	2593	2763	3890	3920	4182
Gx	(mm)	1809	1793	1773	1993	1859	1859	2036	2187	2515	2502	2994	2990	2959
Gy	(mm)	439	434	434	451	449	449	518	515	514	513	495	496	484
A	%	17,9	17,9	18,2	18,8	20,7	20,7	12	12	13	13	19	19	19
B	%	20,8	21,3	21,7	20,8	23,0	23,0	12	12	13	13	15	15	15
C	%	28,4	27,7	27,5	28,7	26,6	26,6	31	31	25	25	22	22	24
D	%	33,0	33,0	32,6	31,7	29,7	29,7	31	31	25	25	17	17	17
E	%	-	-	-	-	-	-	7	7	12	12	4	4	5
F	%	-	-	-	-	-	-	7	7	12	12	4	4	4
G	%	-	-	-	-	-	-	-	-	-	-	11	11	11
H	%	-	-	-	-	-	-	-	-	-	-	8	8	9
VERSIÓN SILENCIADA SIN ACUMULACIÓN ⁽¹⁾														
Dimensiones		0275L	0300L	0325L	0350L	0500L	0550L	0600L	0650L	0700L	0750L	0800L	0900L	1000L
Peso	Kg	638	674	708	786	917,5	932,5	1481	1498	1737	1918	2670	2700	2960
Gx	(mm)	1132	1142	1124	1310	1279	1279	1888	1891	2193	2206	2233	2236	2259
Gy	(mm)	390	389	388	398	396	396	493	490	493	496	480	482	466
A	%	18,9	18,7	19,0	19,5	19,9	19,9	21	21	12	12	19	19	19
B	%	27,2	26,9	27,5	27,0	27,9	27,9	21	21	12	12	15	15	15
C	%	22,1	22,3	21,8	22,4	21,7	21,7	29	29	31	31	22	22	21
D	%	31,8	32,1	31,7	31,1	30,5	30,5	29	29	31	31	17	17	17
E	%	-	-	-	-	-	-	-	-	7	7	4	4	5
F	%	-	-	-	-	-	-	-	-	7	7	4	4	4
G	%	-	-	-	-	-	-	-	-	-	-	11	11	11
H	%	-	-	-	-	-	-	-	-	-	-	8	8	9
VERSIÓN CON ACUMULACIÓN VACÍA ⁽²⁾ (MODELOS SILENCIADOS)														
Dimensiones		0275L	0300L	0325L	0350L	0500L	0550L	0600L	0650L	0700L	0750L	0800L	0900L	1000L
Gx	(mm)	1425	1420	1395	1579	1518	1518	1883	1886	2187	2200	2476	2476	2479
Gy	(mm)	407	405	405	430	409	409	506	504	504	503	503	505	489
VERSIÓN SÓLO CON GRUPO BOMBAS (MODELOS SILENCIADOS)														
Dimensiones		0275L	0300L	0325L	0350L	0500L	0550L	0600L	0650L	0700L	0750L	0800L	0900L	1000L
PESO	(kg)	672	708	742	820	951,5	966,5	1659	1676	1914	2096	2870	2900	3160
VERSIÓN SILENCIADA CON ACUMULACIÓN LLENA DE AGUA (500 litros) ⁽²⁾														
Dimensiones		0275L	0300L	0325L	0350L	0500L	0550L	0600L	0650L	0700L	0750L	0800L	0900L	1000L
Peso	Kg	1336	1400	1410	1505	1634,5	1651,5	2243	2260	1498	2680	3770	3800	4050
Gx	(mm)	1839	1817	1798	2012	1931	1931	1883	1886	2187	2206	3012	3008	2975
Gy	(mm)	432	430	430	445	429	429	506	504	504	496	491	492	480
A	%	17,1	17,4	17,7	18,3	18,7	18,7	21	21	12	12	16	16	16
B	%	20,5	21,0	21,4	20,7	22,8	22,8	21	21	12	12	9	9	9
C	%	28,4	27,9	27,6	28,6	26,4	26,4	29	29	31	31	17	17	18
D	%	34,0	33,7	33,4	32,4	32,1	32,1	29	29	31	31	9	9	10
E	%	-	-	-	-	-	-	-	-	7	7	13	13	14
F	%	-	-	-	-	-	-	-	-	7	7	7	7	7
G	%	-	-	-	-	-	-	-	-	-	-	18	18	18
H	%	-	-	-	-	-	-	-	-	-	-	10	10	10
VARIACIONES DE PESO RESPECTO AL MODELO ESTÁNDAR (KG)														
Pesos agregados		0275	0300	0325	0350	0500	0550	0600	0650	0700	0750	0800	0900	1000
Desrecalentador		6,5	7,5	8,5	10	10	12	14	18	18	24	50	53	56
recuperación total		45	54	63	63	95	95	105	125	125	150	125	138	145

(1) = Pesos y centros de gravedad referidos al modelo sin acumulación 00 sin agua.

(2) = Pesos y centros de gravedad referidos al modelo con acumulación 04. Los modelos 0800 - 0900 - 1000 poseen un volumen de acumulación de 700 litros. Los modelos 0800 - 0900

- 1000 poseen un volumen de acumulación de 700 litros. Las versiones con desrecalentador y aquellas con acumulación 01 02 03 presentan VARIACIONES DE PESO RESPECTO AL MODELO DE REFERENCIA, pero las variaciones de centro de gravedad y distribución de pesos sin irrelevan-

tes. Las versiones con orificios para resistencias integrales (acumulación 05 06 07 08) presentan diferencias irrelevantes respecto del modelo de referencial modelo de riferimento.



carta riciclata
recycled paper
papier recyclé
recycled apier

AERMEC S.p.A.
37040 Bevilacqua (VR) - Italy
Via Roma, 44 - Tel. (+39) 0442 633111
Telefax (+39) 0442 93730 - (+39) 0442 93566
www.aermec.com

The technical data in the following documentation are not binding. AERMEC reserves the right to make all the modifications considered necessary for improving the product at any time.

Los datos técnicos contenidos en este documento no son vinculantes. AERMEC se reserva la facultad de aportar, en cualquier momento, todas las modificaciones consideradas necesarias para la mejora del producto.